

Order key

The order key diagram shows the following breakdown:

- P1V-M**: Air motor range (Robust Air Motor)
- 020**: Motor size (200 W)
- B**: Function (Basic motor without gearbox, keyed shaft)
- 0**: Optional function (Standard vanes)
- A00**: Additional optional functions (None specified)

	Motor size	
020	200 W	
040	400 W	
060	600 W	
090	900 W	
120	1200 W	

	Function	
B	Basic motor without gearbox, keyed shaft	
C	With planetary gear, keyed shaft	

	Optional function	
0	Standard vanes	
Z	Spring loaded vanes	

	Air motor range	
P1V-M	Robust Air Motor	

	Free speed (rpm)								
P1V-M020	10000	2300	1460	540	340	210	120	80	32
P1V-M040	10000	2300	1460	540	340	210	120	80	
P1V-M060	10000	2300	1460	540	340	210	120		
P1V-M090	10500	2450	1560	580	360	230	134	90	
P1V-M120	10500	2450	1560	580	360	230			

Note : This model code can not be used for creating new part numbers. All possible combinations between motor size, function and free speed are in all previous pages except for optional function.

Technical data

Note: All technical data are based on a working pressure of 6 bar and with oil.
For oil-free performances are -10 to 15% lower than data in charts.
Speed tolerance accuracy in between clock and anti-clockwise directions is $\pm 10\%$.

Air motor size & type	P1V-M020	P1V-M040	P1V-M060	P1V-M090	P1V-M120
Nominal power (watts)	200	400	600	900	1200
Working pressure (bar)	3 to 7, 6 in explosive atmosphere				
Working temperature (°C)	-20 to +110				
Ambient temperature (°C)	-20 to +40 in explosive atmosphere				
Air flow required (NI/min)	300	600	900	2200	2600
Min pipe ID, inlet (mm)	10	12	13	13	13
Min pipe ID, outlet (mm)	10	12	13	13	13
Choice of treatment unit: recommended min air flow (l/min) at p1 7.5 bar and 0.8 bar pressure drop					
	330	660	990	2500	2900
Choice of valve: recommended min nominal air flow (l/min) at p1 6 bar and 1 bar pressure drop					
	360	720	1080	2800	3200
Medium	40 μ m filtered, oil mist or dry unlubricated compressed air				
Oil free operation, indoor	ISO8573-1 purity class 3.4.1				
Oil free operation, outdoor	ISO8573-1 purity class 1.2.1				
Oil operation	1-2 drop(s) per cube meter, ISO8573-1 purity class 3.-.5				
Recommended oil	Foodstuffs industry Klüber oil 4 UH1- 32 N				
Sound level free outlet (dB(A))	107	107	107	120	120
With outlet silencer (dB(A))	97	98	99	81	81

Note: Sound levels are measured at free speed with the measuring instrument positioned 1 meter away from the air motor at an height of 1 meter.

Material specification

Air motor size & type	P1V-M020	P1V-M040	P1V-M060	P1V-M090	P1V-M120
Without gear box					
Motor housing	Cast iron, synthetic paint, grey color				
Shaft	Hardened steel				
Key	Hardened steel				
External seal	NBR				
Internal steel parts	High grade steel				
Motor lubrication	Bearings: grease				
Vanes	Patented, no data				
With gear box					
Planetary gearbox	Steel / cast iron, synthetic paint, grey color				
Shaft	Hardened steel				
Key	Hardened steel				
External seal	NBR				
Internal steel parts	High grade steel				
Gearbox lubrication	Grease, Shell Cassida RLS2				

NOTE! All technical data are based on a working pressure of 6 bar and with oil. For oil-free performances are -10 to 15% lower. Speed tolerance accuracy +-10%



Robust motor reversible with keyed shaft, flange

Max power	Free speed*	Nominal speed	Nominal torque	Min start torque	Air consumption at max power	Conn.	Min pipe ID	Weight	Order code
kW	rpm	rpm	Nm	Nm	l/s		mm	Kg	
0,200	10 000	5 000	0,38	0,57	5	G1/8	10	1,00	P1V-M020B0A00
0,400	10 000	5 000	0,76	1,10	10	G3/8	12	1,40	P1V-M040B0A00
0,600	10 000	5 000	1,10	1,70	15	G3/8	13	1,60	P1V-M060B0A00
0,900	10 500	5 250	1,60	2,40	36,7	G1/2	13	3,10	P1V-M090B0A00
1,200	10 500	5 250	2,20	3,30	43,3	G1/2	13	3,80	P1V-M120B0A00

* maximum admissible speed (idling)

P1V-M020B0A00

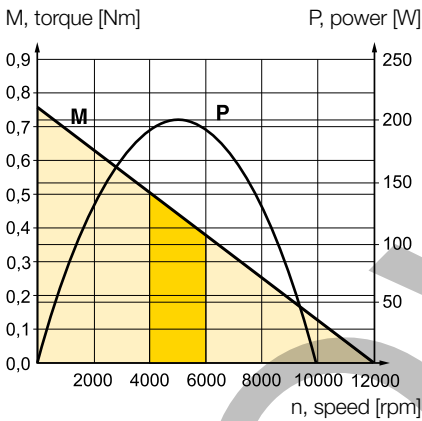

P1V-M040B0A00

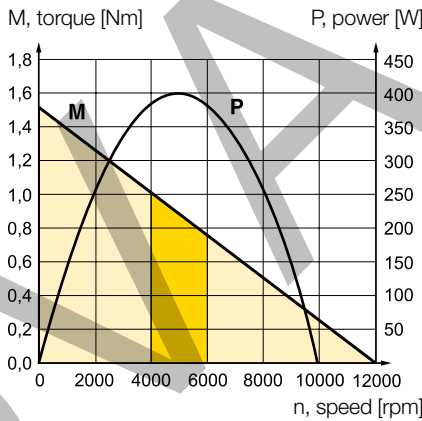

P1V-M060B0A00

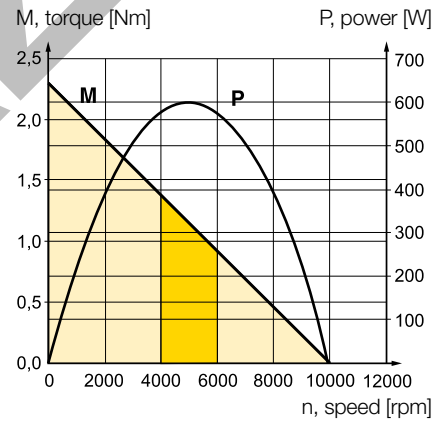

P1V-M090B0A00

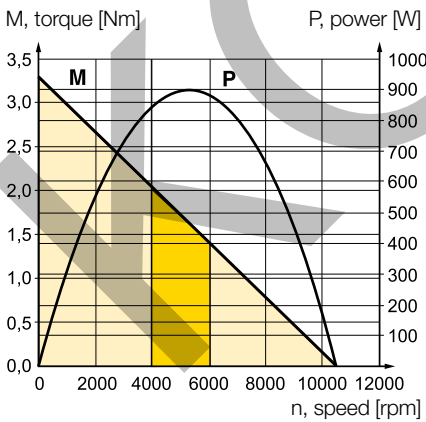

P1V-M120B0A00

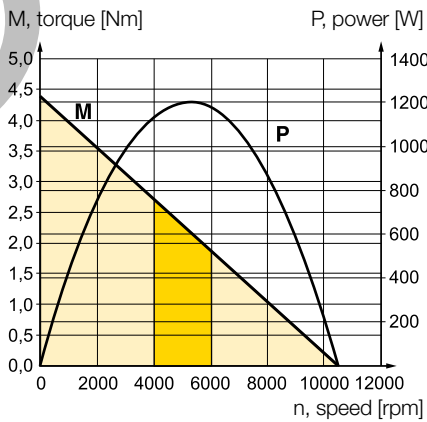

Possible working range of motor.
 Optimum working range of motor.
 Higher speeds = more vane wear
 Lower speeds with high torque = more gearbox wear

Dimensions (mm)

Motor P1V-M020B0A00

Motor P1V-M040B0A00

Motor P1V-M060B0A00

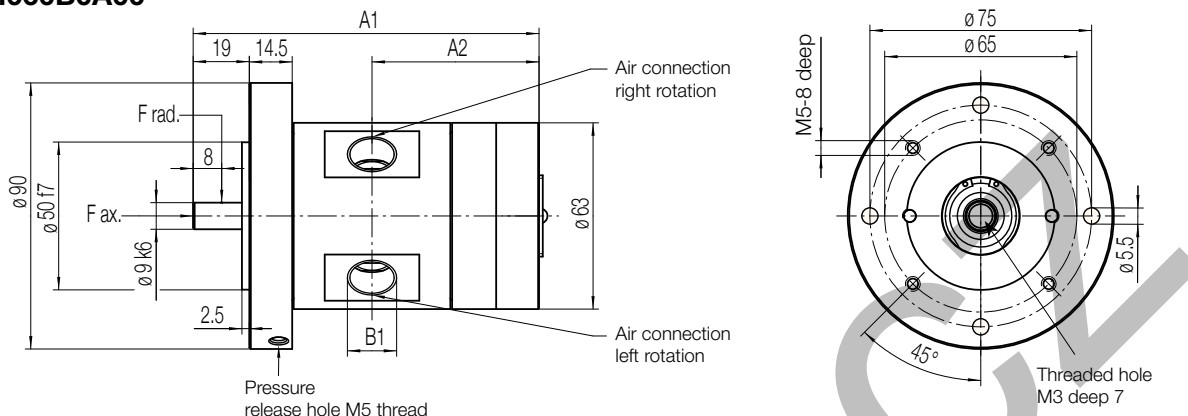

Motor P1V-M090B0A00

Motor P1V-M120B0A00

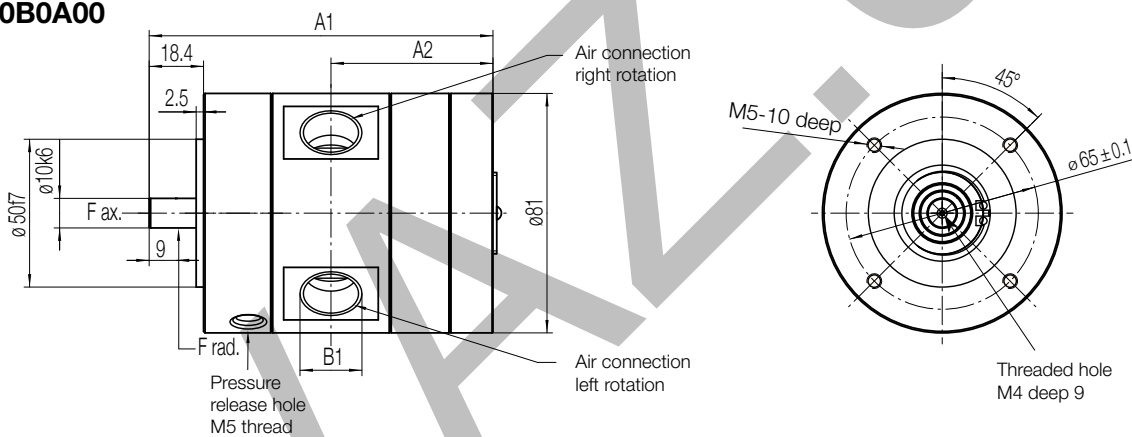

Foot bracket P1V-MF3

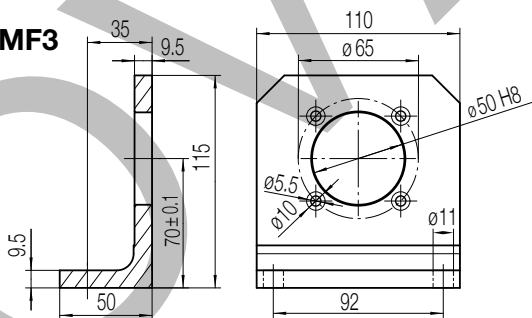

Motor type	Dimensions (mm)			Key on shaft
	A1	A2	B1	
P1V-M020B0A00	82	39	G1/8	DIN6885 A3x3x10
P1V-M040B0A00	102	49	G3/8	DIN6885 A3x3x10
P1V-M060B0A00	117	56.5	G3/8	DIN6885 A3x3x10
P1V-M090B0A00	116.3	54.8	G1/2	DIN6885 A3x3x18
P1V-M120B0A00	136.3	64.3	G1/2	DIN6885 A3x3x18

NOTE! All technical data are based on a working pressure of 6 bar and with oil. For oil-free performances are -10 to 15% lower. Speed tolerance accuracy +-10%

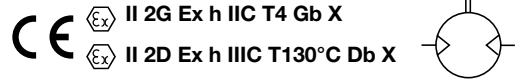

Robust motor reversible with keyed shaft, flange

Max power	Free speed*	Nominal speed	Nominal torque	Min start torque	Air consumption at max power	Conn.	Min pipe ID	Weight	Order code
kW	rpm	rpm	Nm	Nm	l/s		mm	Kg	
1,20	2 450	1 225	9,40	14,00	43,3	G1/2	13	5,60	P1V-M120C0245
1,20	1 560	780	14,70	22,00	43,3	G1/2	13	5,60	P1V-M120C0156
1,20	580	290	40,00	60,00	43,3	G1/2	13	6,30	P1V-M120C0058
1,20	360	180	63,00	94,00	43,3	G1/2	13	6,30	P1V-M120C0036
1,20	230	115	100,00	120**	43,3	G1/2	13	6,30	P1V-M120C0023

* maximum admissible speed (idling) / ** gear box restriction

P1V-M120C0245

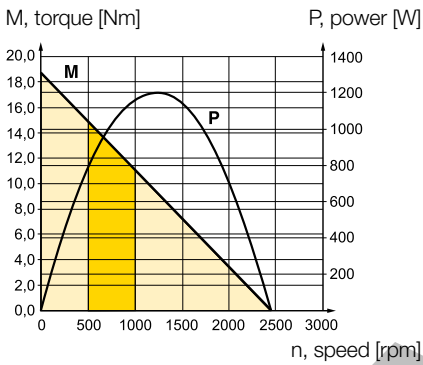

P1V-M120C0156

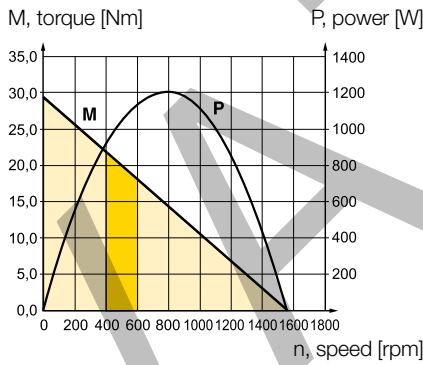

P1V-M120C0058

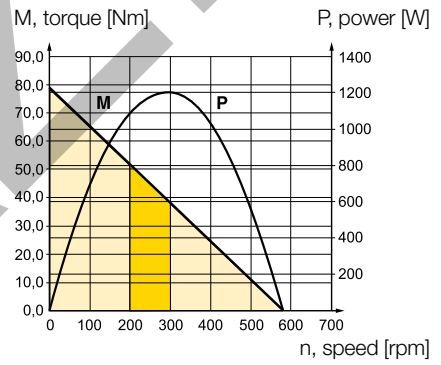

P1V-M120C0036

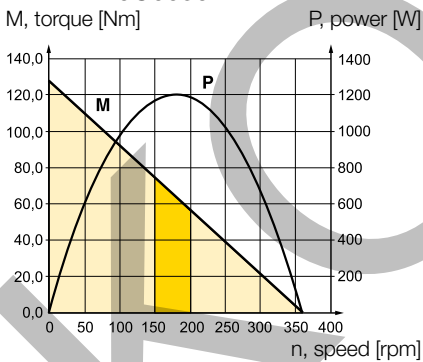

P1V-M120C0023

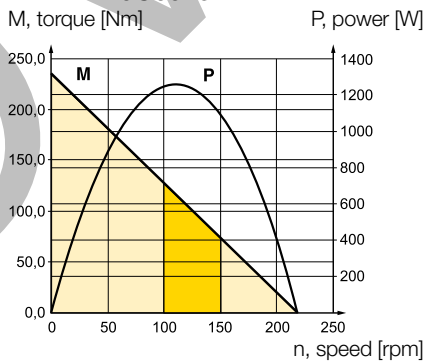

Possible working range of motor.

Optimum working range of motor.
 Higher speeds = more vane wear
 Lower speeds with high torque = more gearbox wear

Dimensions (mm)

Motor P1V-M120C

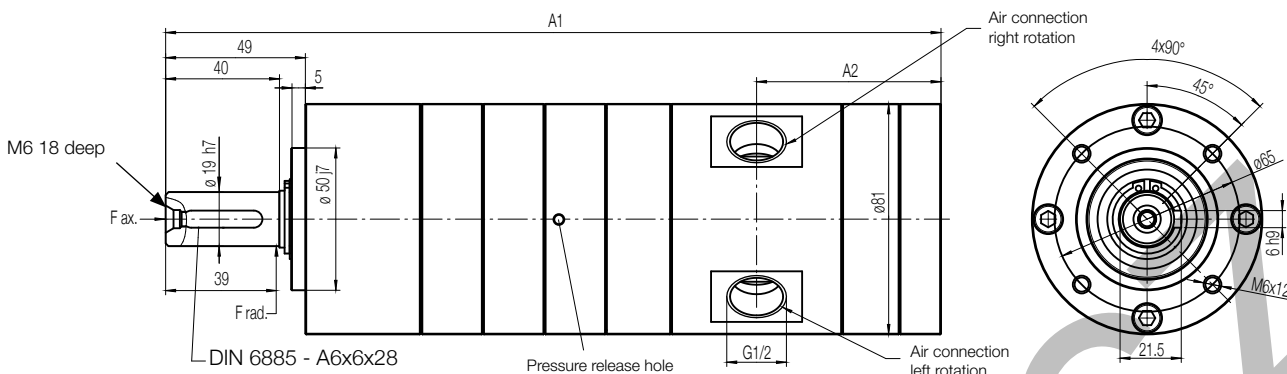

Motors have 2 or 3 openings at the outside of the gearbox which must stay open in order to guarantee troublefree operation.

**Foot bracket
P1V-MF5**

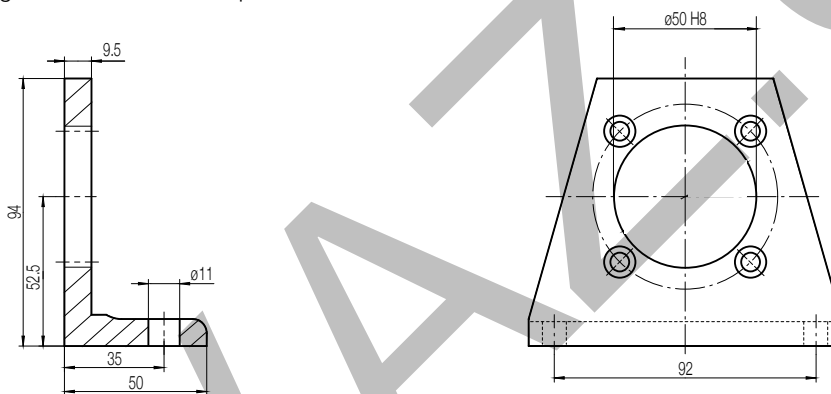

**Flanges
P1V-MF6, P1V-MF7**

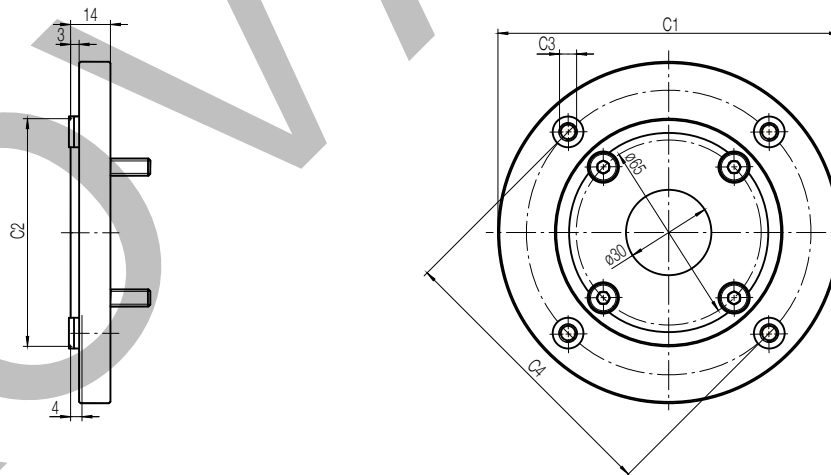

Motor size				Dimensions (mm)	
				A1	A2
1200 watts	P1V-M120C0245	P1V-M120C0156		229	65
	P1V-M120C0058	P1V-M120C0036	P1V-M120C0023	251	65

Motor type					Dimensions (mm)			
					C1	C2	C3	C4
P1V-M120C	(IEC80 B5) P1V-MF7				200	130f7	11	165
	(IEC80 B14) P1V-MF6				120	80f7	M6	100