

## 7321B Series

Solenoid Valves for water, light oils and steam

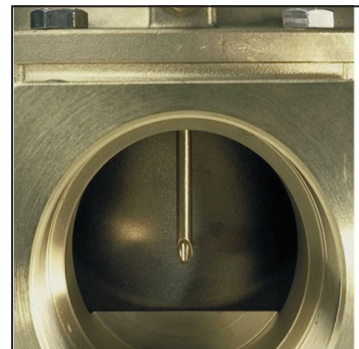

ENGINEERING YOUR SUCCESS.

# 7321B/7322B Series

---

7321B 2/2 pilot operated valves are the best solution anywhere a perfect control media , such water, steam, and light oils, is required.

This product line provides a high flow rate, a fast reaction time, and a superior reliability in a robust and modern design.

Our 7321B Series can be associated with the most of our FCSE coil ranges, including ATEX, and IP67 electrical parts.

## Applications

---

7321B Series can be used to control water, hot water, and steam , in plumbing , industrial washing machines, car wash installations, cooling of machine tools, hydrocleaners, autoclaves and irrigation systems.

## Benefits

---

- High performing with low and high operating pressure differential
- Exclusive diaphragm design for a Superior Flow Rate
- Modular concept: a wide range of electrical parts increase the versatility of this product
- Manual override and speed control options

# Material Specifications

---

<b>Valve body:</b>	CW617N UNI EN 12165:98 Forged Brass
<b>Enclosing tube:</b>	AISI 304 stainless steel
<b>Plunger:</b>	AISI 430F St. Steel
<b>Spring:</b>	AISI 302 St. Steel
<b>Seals:</b>	NBR (Buna N) - EPDM FKM (Viton)
<b>Shading ring:</b>	Copper

## Installation

---

Valves can be mounted in any position. It is however recommended to install them with the coil in a vertical position above the body.

## Media

---

These valves have been developed to achieve the best performances for water, steam and light oils (up to 2°E). 7321B Series can not be used with gases and air.

We recommend choosing NBR versions for water (max. temp. 90°C), FKM version for water/light oils control (applications up to 140°C) EPDM version for superheated water and steam (up to 140°C)

# Options

## Manual Override

7321B Series (NC version only) can be ordered with Manual override to operate the valve without connecting the coil.

**The control consists of a slotted-head screw for a screwdriver and has two possible positions:**

**Closed:** The letter "C" is in the upper position of the screw head (fig.1,2)

**Open:** The letter "A" is in the upper position of the screw head (fig.1,2)

Manual override must be restored to its original position (Closed) to operate the valve through the solenoid control.

Standing in its closed position, the valve operates normally when the coil is energised/de-energised. Manual and speed control are standard on 2 ½" and 3" versions.

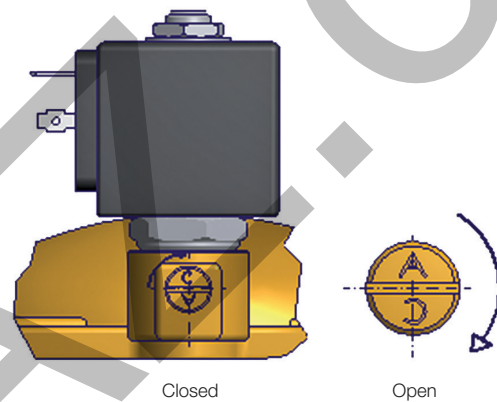

## Speed Control Option (Anti-Water Hammer Control)

Parker 7321B Series (NC version only) is available with a Speed control option. The closure time of certain types can be changed by means of the adjusting screw. The latter, by acting as a throttle on the inlet equalisation (pilot) hole of the valve, slows down the closure speed of the valve, thus reducing the water hammer effect.

**The regulation range is as follows:**

**Screw fully open:** Max. closure speed

**Screw fully closed:** Valve always open

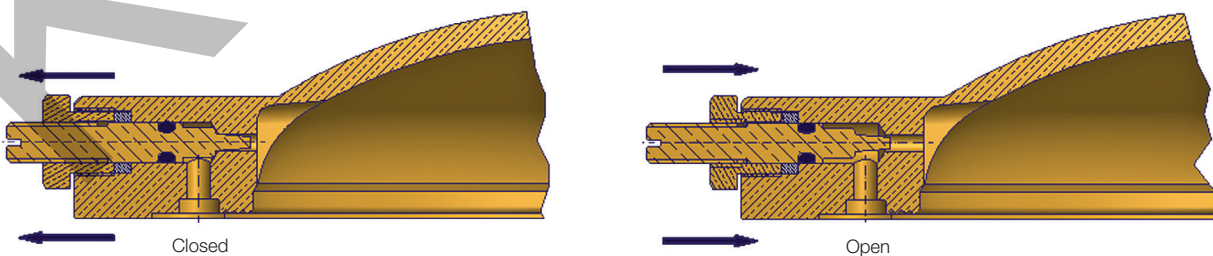

Please consult diagrams on page 5 of this catalogue for details of shut-off response time with speed control option.

# Diagrams of the Closing Times

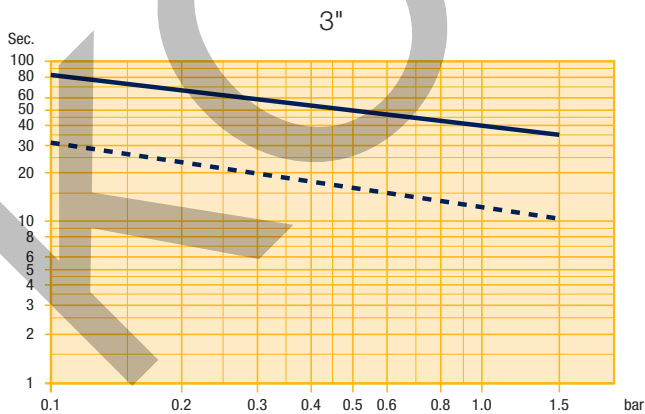
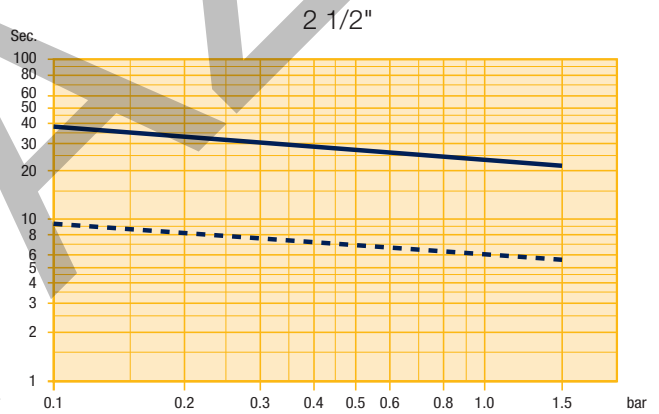
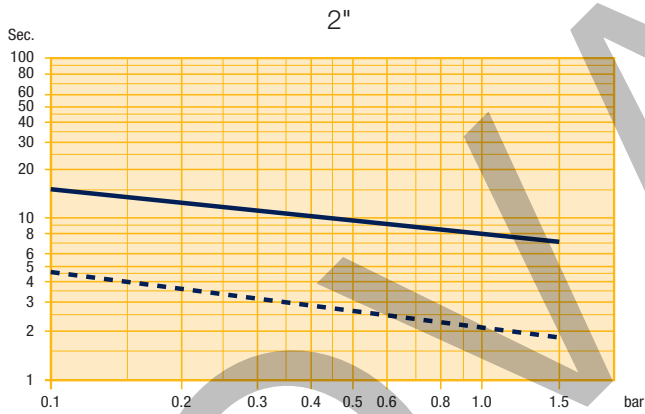
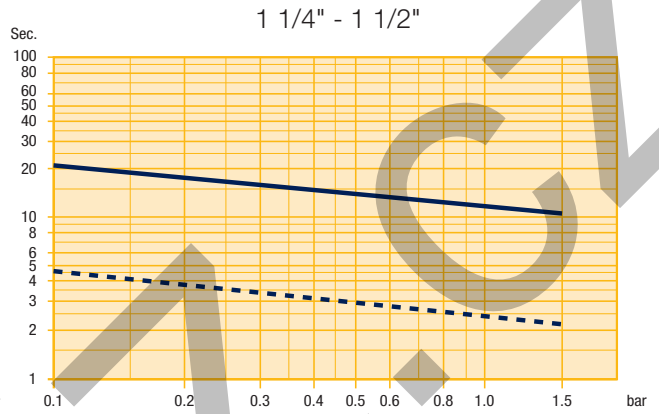
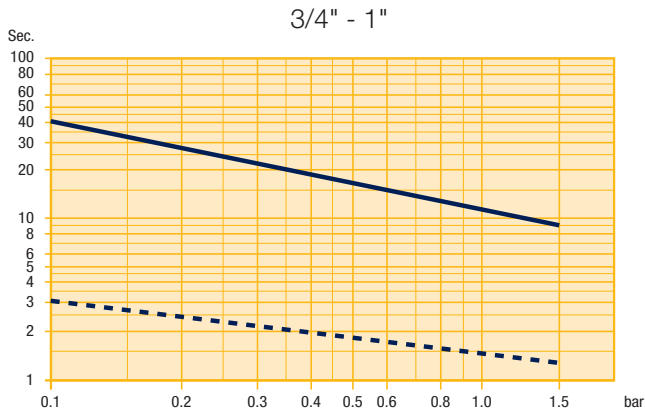

- **Curve 1:** Closing time with adjusting screw completely open
- - - **Curve 2:** Closing time with adjusting screw open by 1/2 turn

# 2/2 Normally Closed

## BRASS PIPE MOUNTING

### NORMALLY CLOSED

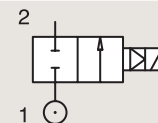

Port size	Orifice Ø	Flow factors		Operating Pressure Differential			Fluid Temp.		Seat Seal	Valve Order Number	Valve Type	Coil Group	Dwg. No.
		Kv l/min	KV m³/h	Min bar	Max(MOPD) AC bar	DC bar	Min °C	Max °C					
3/8"	13	50	3	0.1	20	20	-10	90	NBR	443776W	7321BIN00	2.0/2.1/2.2	1
	13	50	3	0.1	20	20	-10	90	NBR	443777W <sub>2</sub>	7321BIN01	2.0/2.1/2.2	1
	13	50	3	0.1	10	10	-10	140	EPDM	443778W <sub>1</sub>	7321BIH00	2.0/2.1/2.2	1
	13	50	3	0.1	20	20	-10	140	FKM	444492W	7321BIV00	2.0/2.1/2.2	1
1/2"	13	50	3	0.1	20	20	-10	90	NBR	443779W	7321BAN00	2.0/2.1/2.2	1
	13	50	3	0.1	20	20	-10	90	NBR	443780W <sub>2</sub>	7321BAN01	2.0/2.1/2.2	1
	13	50	3	0.1	10	10	-10	140	EPDM	443781W <sub>1</sub>	7321BAH00	2.0/2.1/2.2	1
	13	50	3	0.1	20	20	-10	140	FKM	444494W	7321BAV00	2.0/2.1/2.2	1
3/4"	20	140	8.4	0.1	20	20	-10	90	NBR	443782W	7321BCN00	2.0/2.1/2.2	2
	20	140	8.4	0.1	10	10	-10	90	NBR	443783W <sub>2</sub>	7321BCN01	2.0/2.1/2.2	2
	20	140	8.4	0.1	10	10	-10	140	EPDM	443785W <sub>1</sub>	7321BCH00	2.0/2.1/2.2	2
	20	140	8.4	0.1	20	20	-10	140	FKM	444497W	7321BCV00	2.0/2.1/2.2	2
1"	25	160	9.6	0.1	20	20	-10	90	NBR	443786W	7321BDN00	2.0/2.1/2.2	2
	25	160	9.6	0.1	10	10	-10	90	NBR	443787W <sub>2</sub>	7321BDN01	2.0/2.1/2.2	2
	25	160	9.6	0.1	10	10	-10	140	EPDM	443789W <sub>1</sub>	7321BDH00	2.0/2.1/2.2	2
	25	160	9.6	0.1	20	20	-10	140	FKM	443804W	7321BDV00	2.0/2.1/2.2	2
1 1/4"	35	420	25.2	0.1	10	10	-10	140	EPDM	443793W <sub>1</sub>	7321BEH00	2.0/2.1/2.2	3
	35	420	25.2	0.1	10	10	-10	90	NBR	443790W	7321BEN00	2.0/2.1/2.2	3
	35	420	25.2	0.1	5	5	-10	90	NBR	443791W <sub>2</sub>	7321BEN01	2.0/2.1/2.2	3
1 1/2"	40	500	30	0.1	10	10	-10	140	EPDM	443797W <sub>1</sub>	7321BFH00	2.0/2.1/2.2	3
	40	500	30	0.1	10	10	-10	90	NBR	443794W	7321BFN00	2.0/2.1/2.2	3
	40	500	30	0.1	5	5	-10	90	NBR	443795W <sub>2</sub>	7321BFN01	2.0/2.1/2.2	3
2"	50	620	37.2	0.1	10	10	-10	140	EPDM	443801W <sub>1</sub>	7321BGH00	2.0/2.1/2.2	3
	50	620	37.2	0.1	10	10	-10	90	NBR	443798W	7321BGN00	2.0/2.1/2.2	3
	50	620	37.2	0.1	5	5	-10	90	NBR	443799W <sub>2</sub>	7321BGN01	2.0/2.1/2.2	3

#### Notes:

1. Maximum pressure for steam: 4 bar (140 °C)
2. With manual override

# 2/2 Normally Closed

With speed control

BRASS

PIPE MOUNTING

NORMALLY CLOSED

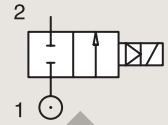

Port size	Orifice Ø	Flow factors		Operating Pressure Differential			Fluid Temp.		Seat Seal	Valve Order Number	Valve Type	Coil Group	Dwg. No.
		Kv l/min	KV m³/h	Min	Max(MOPD)	DC bar	Min	Max					
BSP	mm			bar	AC bar	DC bar	°C	°C					
3/4"	20	140	8.4	0.1	10	10	-10	90	NBR	443784W	7321BCN02	2.0/2.1/2.2	3
1"	25	160	9.6	0.1	10	10	-10	90	NBR	443788W	7321BDN02	2.0/2.1/2.2	3
1 1/4"	35	420	25.2	0.1	5	5	-10	90	NBR	443792W	7321BEN02	2.0/2.1/2.2	2
1 1/2"	40	500	30	0.1	5	5	-10	90	NBR	443796W	7321BFN02	2.0/2.1/2.2	2
2"	50	620	37.2	0.1	5	5	-10	90	NBR	443800W	7321BGN02	2.0/2.1/2.2	2
2 1/2"	65	1100	66	0.2	10	10	-10	90	NBR	443802W	7321BLN02	2.0/2.1/2.2	4
3"	75	1334	80	0.2	10	10	-10	90	NBR	443803W	7321BMN02	2.0/2.1/2.2	4



# 2/2 Normally Open

BRASS

PIPE MOUNTING

NORMALLY OPEN

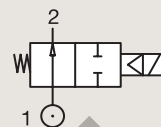

Port size	Orifice Ø	Flow factors		Operating Pressure Differential			Fluid Temp.		Seat Seal	Valve Order Number	Valve Type	Coil Group	Dwg. No.
		Kv l/min	KV m <sup>3</sup> /h	Min bar	Max(MOPD) AC bar	DC bar	Min °C	Max °C					
3/8"	13	50	3	0.1	20	20	-10	90	NBR	443805W	7322BIN00	2.0/2.1/2.2	1
	13	50	3	0.1	10	10	-10	140	EPDM	444600W <sub>1</sub>	7322BIH00	2.0/2.1/2.2	1
	13	50	3	0.1	20	20	-10	140	FKM	444499W	7322BIV00	2.0/2.1/2.2	1
1/2"	13	50	3	0.1	20	20	-10	90	NBR	443806W	7322BAN00	2.0/2.1/2.2	1
	13	50	3	0.1	10	10	-10	140	EPDM	444601W <sub>1</sub>	7322BAH00	2.0/2.1/2.2	1
	13	50	3	0.1	20	20	-10	140	FKM	444500W	7322BAV00	2.0/2.1/2.2	1
3/4"	20	140	8.4	0.1	20	20	-10	90	NBR	443807W	7322BCN00	2.0/2.1/2.2	3
	20	140	8.4	0.1	10	10	-10	140	EPDM	444602W <sub>1</sub>	7322BCH00	2.0/2.1/2.2	3
1"	25	160	9.6	0.1	20	20	-10	90	NBR	443808W	7322BDN00	2.0/2.1/2.2	3
	25	160	9.6	0.1	10	10	-10	140	EPDM	444603W <sub>1</sub>	7322BDH00	2.0/2.1/2.2	3
	25	160	9.6	0.1	20	20	-10	140	FKM	444502W	7322BDV00	2.0/2.1/2.2	3
1 1/4"	35	420	25.2	0.1	10	10	-10	90	NBR	443809W	7322BEN00	2.0/2.1/2.2	2
	35	420	25.2	0.1	10	10	-10	140	EPDM	444576W <sub>1</sub>	7322BEH00	2.0/2.1/2.2	2
1 1/2"	40	500	30	0.1	10	10	-10	90	NBR	443810W	7322BFN00	2.0/2.1/2.2	2
	40	500	30	0.1	10	10	-10	140	EPDM	444604W <sub>1</sub>	7322BFH00	2.0/2.1/2.2	2
2"	50	620	37.2	0.1	10	10	-10	90	NBR	443811W	7322BGN00	2.0/2.1/2.2	2
	50	620	37.2	0.1	10	10	-10	140	EPDM	444605W <sub>1</sub>	7322BGH00	2.0/2.1/2.2	2
2 1/2"	65	1100	66	0.2	10	10	-10	90	NBR	444513W <sub>2</sub>	7322BLN06	2.0/2.1/2.2	4
3"	75	1334	80	0.2	10	10	-10	90	NBR	444503W <sub>2</sub>	7322BMN06	2.0/2.1/2.2	4

**Notes:**

1. Maximum pressure for steam: 4 bar (140 °C)
2. Speed Control



## 2/2 Normally Closed - NPT threads

Port Size NPT	Orifice		Flow Factors		Minimum Pressure		Maximum Differential		Fluid Temp.		Seat Seal	Part Number	Description	Coil Group	Dwg. No.
	mm	inch	m <sup>3</sup> /h	gpm	bar	PSI	bar	PSI	Min °C	Max °C					
3/8"	13	0.51	3.0	13.23	0.1	1.45	20	290	-10	90	NBR	444107W	7321BIN90	2.0/2.1/2.2	1
	13	0.51	3.0	13.23	0.1	1.45	10	145	-10	140	EPDM	444209W <sub>1</sub>	7321BIH90	2.0/2.1/2.2	1
1/2"	13	0.51	3.0	13.23	0.1	1.45	20	290	-10	90	NBR	444108W	7321BAN90	2.0/2.1/2.2	1
	13	0.51	3.0	13.23	0.1	1.45	10	145	-10	140	EPDM	444210W <sub>1</sub>	7321BAH90	2.0/2.1/2.2	1
3/4"	20	0.78	8.4	37.04	0.1	1.45	20	290	-10	90	NBR	444109W	7321BCN90	2.0/2.1/2.2	2
	20	0.78	8.4	37.04	0.1	1.45	10	145	-10	140	EPDM	444211W <sub>1</sub>	7321BCH90	2.0/2.1/2.2	2
1"	25	0.98	9.6	42.34	0.1	1.45	20	290	-10	90	NBR	444110W	7321BDN90	2.0/2.1/2.2	2
	25	0.98	9.6	42.34	0.1	1.45	10	145	-10	140	EPDM	444606W <sub>1</sub>	7321BDH90	2.0/2.1/2.2	2
1 1/4"	35	1.37	25.2	111.13	0.1	1.45	10	145	-10	90	NBR	444168W	7321BEN90	2.0/2.1/2.2	3
1 1/2"	40	1.56	30.0	132.30	0.1	1.45	10	145	-10	90	NBR	444169W	7321BFN90	2.0/2.1/2.2	3
2"	50	1.95	37.2	164.05	0.1	1.45	10	145	-10	90	NBR	444119W	7321BGN90	2.0/2.1/2.2	3

### Notes:

1. Maximum pressure for steam: 4 bar (140 °C)

## 2/2 Normally Open - NPT threads

Port Size NPT	Orifice		Flow Factors		Minimum Pressure		Maximum Differential		Fluid Temp.		Seat Seal	Part Number	Description	Coil Group	Dwg. No.
	mm	inch	m <sup>3</sup> /h	gpm	bar	PSI	bar	PSI	Min °C	Max °C					
3/8"	13	0.51	3.0	13.23	0.1	1.45	20	290	-10	90	NBR	444234W	7322BIN90	2.0/2.1/2.2	1
	13	0.51	3.0	13.23	0.1	1.45	10	145	-10	140	EPDM <sub>1</sub>	444613W	7322BIH90	2.0/2.1/2.2	1
1/2"	13	0.51	3.0	13.23	0.1	1.45	20	290	-10	90	NBR	444610W	7322BAN90	2.0/2.1/2.2	1
3/4"	20	0.78	8.4	37.04	0.1	1.45	20	290	-10	90	NBR	444611W	7322BCN90	2.0/2.1/2.2	2
	20	0.78	8.4	37.04	0.1	1.45	10	145	-10	140	EPDM <sub>1</sub>	444109W	7322BCH90	2.0/2.1/2.2	2
1"	25	0.98	9.6	42.34	0.1	1.45	20	290	-10	90	NBR	444612W	7322BDN90	2.0/2.1/2.2	2
	25	0.98	9.6	42.34	0.1	1.45	10	145	-10	140	EPDM <sub>1</sub>	444110W	7322BDH90	2.0/2.1/2.2	2
1 1/4"	35	1.37	25.2	111.13	0.1	1.45	10	145	-10	90	NBR	444320W	7322BEN90	2.0/2.1/2.2	3
	35	1.37	25.2	111.13	0.1	1.45	10	145	-10	140	EPDM <sub>1</sub>	444576W	7322BEH90	2.0/2.1/2.2	3

### Notes:

1. Maximum pressure for steam: 4 bar (140 °C)

# Dimensional Drawings

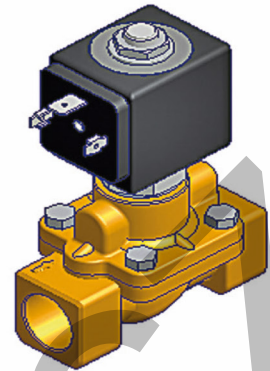
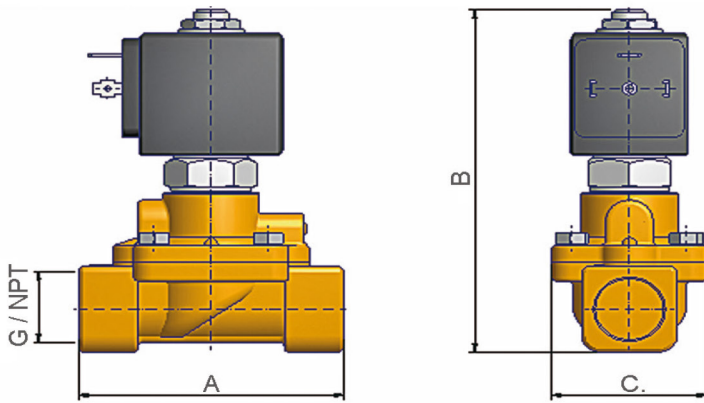

Function	Connections		A		B		C	
	BSP	NPT	mm	inch	mm	inch	mm	inch
Normally Closed	3/8"		69	2.71	99.5	3.91	40	1.57
	1/2"		72	2.83	101.5	3.99	40	1.57
Normally Open	3/8"		69	2.71	110	4.33	40	1.57
	1/2"		72	2.83	112	4.41	40	1.57

Dimensional Drawing 1

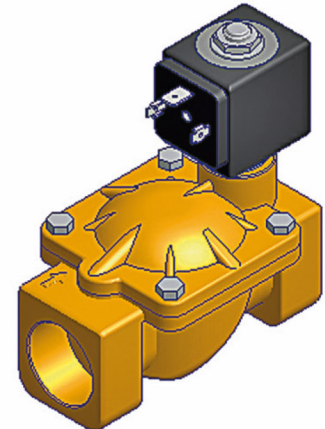
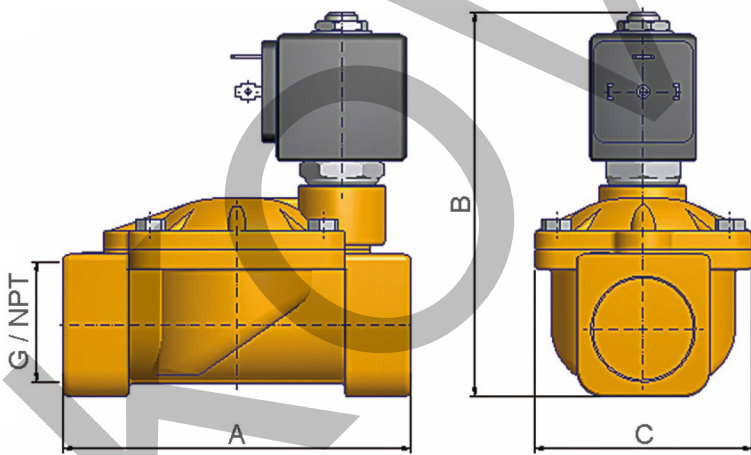

Function	Connections		A		B		C	
	BSP	NPT	mm	inch	mm	inch	mm	inch
Normally Closed	3/4"		100	3.83	107	4.21	65	2.55
	1"		104	4.09	112.5	4.42	65	2.55
Normally Open	3/4"		100	3.83	117.5	4.62	65	2.55
	1"		104	4.09	123	4.84	65	2.55

Dimensional Drawing 2

# Dimensional Drawings

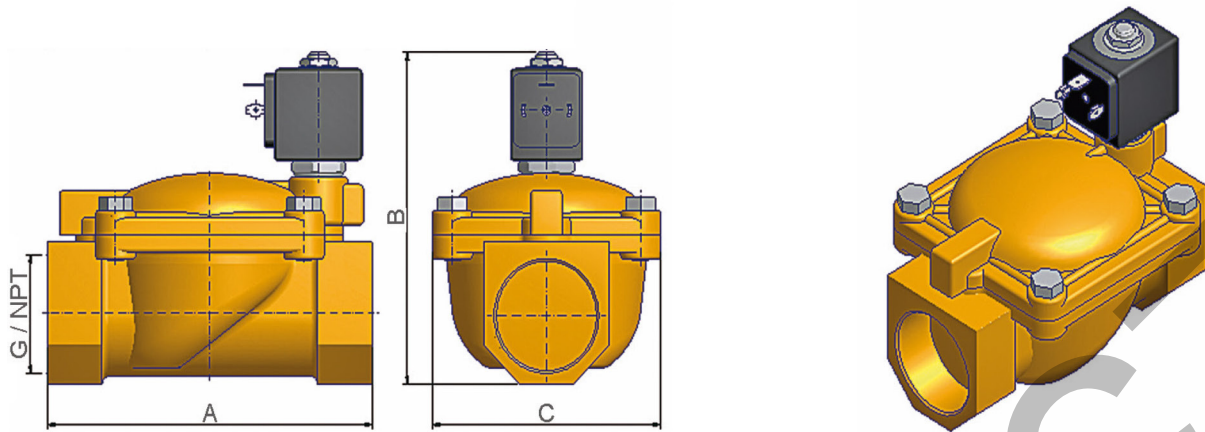

Function	Connections		A		B		C	
	BSP	NPT	mm	inch	mm	inch	mm	inch
Normally Closed	1 1/4"		145	5.70	134	5.27	102	4.01
	1 1/2"		145	5.70	134	5.27	102	4.01
	2"		173	6.81	148	5.82	118	4.64
Normal Open	1 1/4"		145	5.70	144.5	5.68	102	4.01
	1 1/2"		145	5.70	134	5.27	102	4.01
	2"		173	6.81	148	5.82	118	4.64

Dimensional Drawing 3

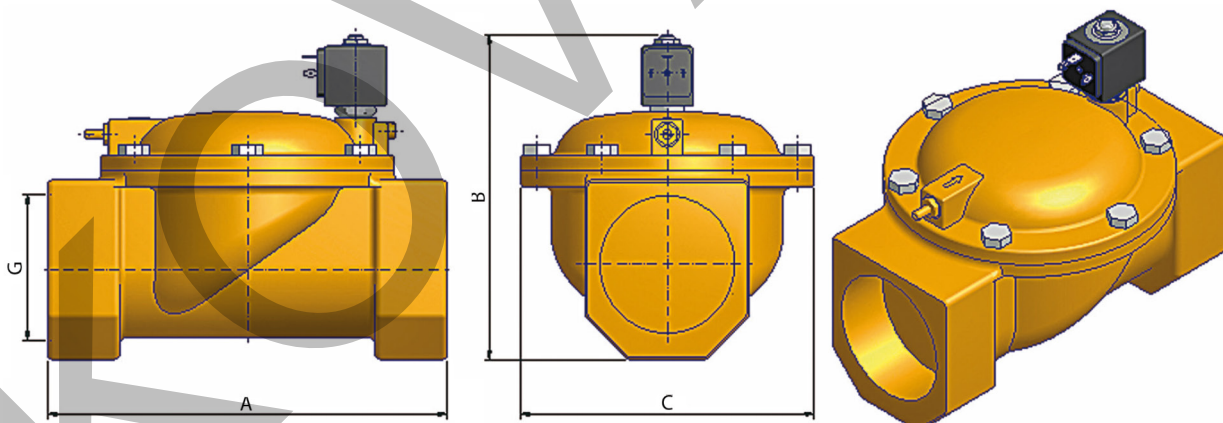

Function	Connections	A		B		C	
		mm	inch	mm	inch	mm	inch
Normally Closed	2 1/2"	245	9.64	195	7.67	184	7.24
	3"	250	9.84	195	7.67	184	7.24
Normally Open	2 1/2"	245	9.64	205	8.07	184	7.24
	3"	245	9.64	205	8.07	184	7.24

Dimensional Drawing 4

# Coil Availability

COILS

Coil group  
**2.0/2.1**

## COILS FOR DIN PLUG CONNECTION



These coils can be mounted with every Parker solenoid valve corresponding to the specified Coil Group.

See column "Coil Group" in the valve pages.

This is an encapsulated assembly comprising a coil, integral magnetic iron path, and snap-on plug connection.

The synthetic material encapsulation provides an effective compact housing, offering full protection against dust, oil, water, etc.

Ease of mounting in a confined space - offers shock and corrosion protection - simplifies conversion of existing equipment to other requirements, etc.

Coils conform to the IEC/CENELEC safety standards and comply with European low-voltage directive.

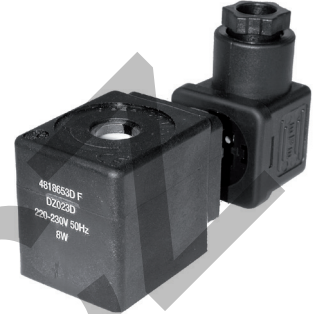

Specification		Standard			Double frequency		
Ref. (without DIN plug) Ref. (with DIN plug)		481865			483510		
Coil Group		2.0 / 2.1					
Degree of protection		IP65 according to IEC / EN 60529 standards (with DIN plug).					
Class of insulation		F 155°C					
Electrical connection		The coil is connected with a 2 P + E plug according to EN 175301-803 type A					
Ambient temperature		-40°C to +50°C The application is limited also by the temperature range of the valve.					
Elect. Power	DC	Pn (hot)	9 W				-
		P (cold) 20°C	12 W				-
	AC	Pn (holding)	8 W				9 W
		Attraction cold	26 VA (9 W)				32 VA (10 W)
Weight		130 g (without plug)					
Voltages "Un"		VAC/Hz	Code	VDC	Code	VAC/Hz	Code
-10% to +10% of the Un		24/50	A2	24	C2	24/50, 24/60	P0
		48/50	A4	48	C4	48/50, 48/60	S4
		110/50	A5	110	C5	110-115/50, 120/60	S5
		220-230/50	3D			220-240/50, 240/60	S6

To Order a Coil choose Coil Ref + Voltage Code, example: 481865 for 24 VDC = 481865C2

More voltage possibilities can be found in the table of voltage codes at the end of the coil section.

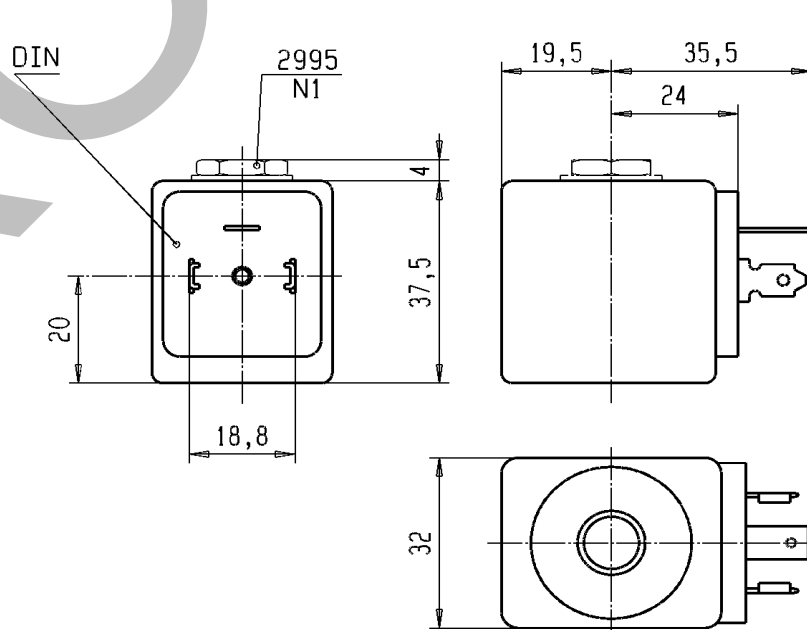

Coil group  
**2.0/2.1**

**COILS FOR DIN PLUG CONNECTION**



This coil can be mounted with every Parker solenoid valve corresponding to the specified Coil Group.

See column "Coil Group" in the valve pages.

This is an encapsulated assembly comprising a coil, integral magnetic iron path, and snap-on plug connection.

The synthetic material encapsulation provides an effective compact housing, offering full protection against dust, oil, water, etc.

Ease of mounting in a confined space - offers shock and corrosion protection - simplifies conversion of existing equipment to other requirements, etc.

Coils conform to the IEC/CENELEC safety standards and comply with European low-voltage directive.

DIN plug connector to be ordered separately (see coil accessories section)



Specification		UL-recognized coil - UL File E200N - designation AMIF			
Reference (without DIN plug)		491514			
Coil Group		2.0 / 2.1			
Degree of protection		IP65 according to IEC / EN 60529 standards (with DIN plug).			
Class of insulation		F (155°C)			
Electrical connection		The coil is connected with a 2 P + E plug according to EN 175301-803 type A			
Ambient temperature		-40°C to 50°C The application is limited also by the temperature range of the valve.			
Elect. Power	DC	Pn (hot)	-	12 W	
		P (cold) 20°C	-	16 W	
	AC	Pn (holding)	11 W	-	
		Attraction cold	40 VA (13 W)	-	
Weight		130 g (without plug)			
Voltages "Un"		VAC/Hz	Code	VDC	Code
- 15% to +10% of the Un		110/50-120/60	P3	24	C2
		220/50-240/60	Q3		

To Order a Coil choose Coil Ref + Voltage Code, example: 491514 for 24 VDC = 491514C2

More voltage possibilities can be found in the table of voltage codes at the end of the coil section.

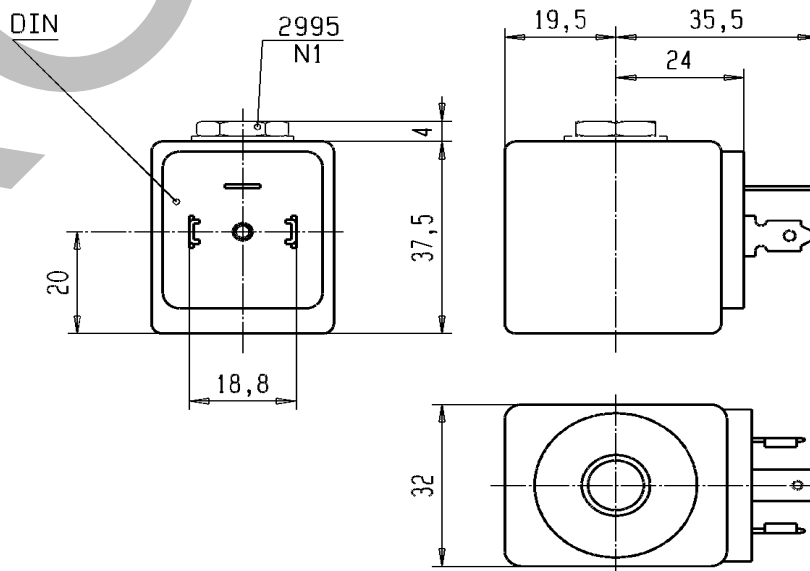

Coil group  
**2.0/2.1**

**IP67 COILS WITH FLYING LEADS**



This coil can be mounted with every Parker solenoid valve corresponding to the specified Coil Group.

See column "Coil Group" in the valve pages.

This is an encapsulated assembly comprising a coil, integral magnetic iron path, and snap-on plug connection.

The synthetic material encapsulation provides an effective compact housing, offering full protection against dust, oil, water, etc.

Ease of mounting in a confined space - offers shock and corrosion protection - simplifies conversion of existing equipment to other requirements, etc.

Coils conform to the IEC/CENELEC safety standards and comply with European low-voltage directive.



Specification		UL Coil with two 500 mm flying leads			
Reference		496081			
Coil Group		2.0 / 2.1			
Degree of protection		IP67 according to IEC / EN 60529 standards			
Class of insulation		F 155°C			
Ambient temperature		-40°C to +50°C The application is limited also by the temperature range of the valve.			
Elect. Power	DC	Pn (hot)	9 W		
		P (cold) 20°C	-		
	AC	Pn (holding)	9 W		
		Attraction cold	32 VA		
Weight		180 g			
Voltages "Un"		VAC/Hz	Code	VDC	Order Number
-10% to +10% of Un for AC		24/50 - 24/60	P0	24	C2
- 5 % to + 10 % for Un DC		110-115/50 - 120/60	S5	12	C1
		220-240/50 - 240/60	S6		

To Order a Coil: Add voltage code after the coil reference number -Code Example: 496081 for 24 VDC =496081C2  
More voltage possibilities can be found in the table of voltage codes at the end of the coil section.

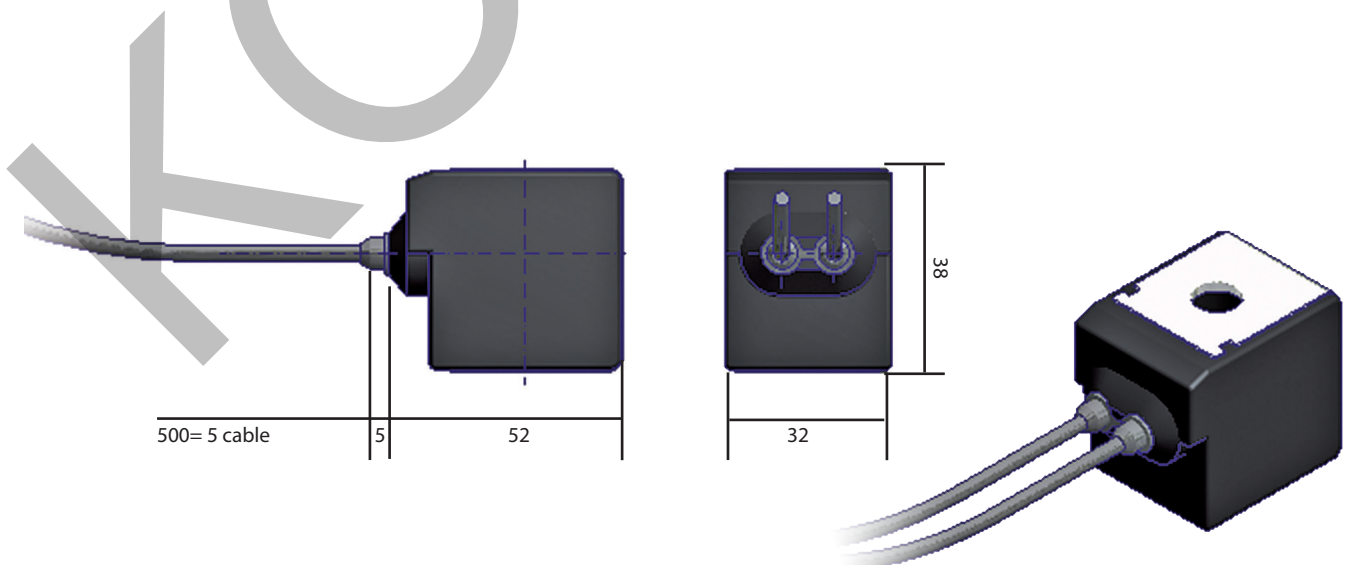



Coil group  
**2.0/2.2**

**IP67 COILS WITH FLYING LEADS**



This coil can be mounted with every Parker solenoid valve corresponding to the specified Coil Group.

See column "Coil Group" in the valve pages.

This is an encapsulated assembly comprising a coil, integral magnetic iron path, and snap-on plug connection.

The synthetic material encapsulation provides an effective compact housing, offering full protection against dust, oil, water, etc.

Ease of mounting in a confined space - offers shock and corrosion protection - simplifies conversion of existing equipment to other requirements, etc.

Coils conform to the IEC/CENELEC safety standards and comply with European low-voltage directive.



Specification		UL Coil with two 500 mm flying leads			
Reference		496082			
Coil Group		2.0 / 2.2			
Degree of protection		IP67 according to IEC / EN 60529 standards			
Class of insulation		F 155°C			
Ambient temperature		-40°C to +50°C The application is limited also by the temperature range of the valve.			
Elect. Power	DC	Pn (hot)	12 W		
		P (cold) 20°C	16 W		
	AC	Pn (holding)	13-14 W		
		Attraction cold	40 VA		
Weight		180 g			
Voltages "Un"		VAC/Hz	Code	VDC	Order Number
-10% to +10% of Un for AC		220/50 - 240/60	Q3	24	C1
- 5 % to + 10 % for Un DC				12	C2

To Order a Coil: Add voltage code after the coil reference number- Code Example: 496082 for 24 VDC= 496082C2  
More voltage possibilities can be found in the table of voltage codes at the end of the coil section.

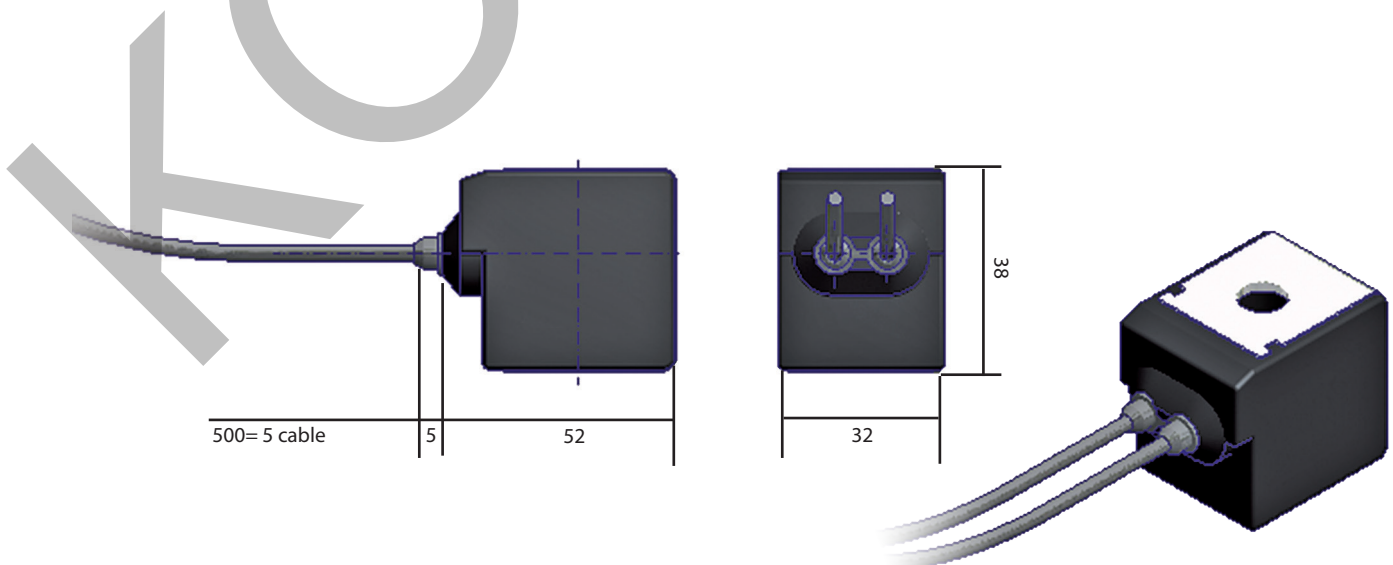



Coil group  
**2.0/2.1**

**FLAME PROOF ENCAPSULATED  
ELECTRICAL PARTS "db mb"**



These coils can be mounted with every Parker ATEX solenoid valve corresponding to the specified Coil Group.

See column "Coil Group" in the valve pages.

Application: Control of solenoid valves in dangerous areas where explosion-proof protection Ex db mb IIC T4 is required.

Benefits: Rotatable 360° fibreglass-reinforced plastic housing (class H). Solenoid coil, rectifier (silicium diodes), fuses and varistor protection are completely encapsulated into the coil housing by epoxy resin for shock and corrosion protection.

The plastic housing is delivered with M20 x 1.5 cable gland certified for use "db" protection. Small size for ease of mounting in a confined space.



<b>Reference</b>	495905		495905.05*	
<b>Certificate</b>	LCIE 03 ATEX 6451 X - IECEx LCI 06.0004 X			
<b>Coil Group</b>	2.0 / 2.1			
<b>Type of protection</b>	<b>Gas</b>	II 2 G - Ex db mb IIC T4		
	<b>Dust</b>	II 2 D - Ex tb IIIC - 130°C		
<b>Degree of protection</b>	IP67 according to IEC/EN 60529 Standards			
<b>Ambient temperature</b>	-40°C to +80°C The application is limited also by the temperature range of the valve.			
<b>Class of insulation</b>	H (180 °)			
<b>Electrical connection</b>	Electrical connection is done in the connection box easily accessible connector terminals. The introduction of the cable (Ø min 5 mm, Ø max. 11 mm, section max. 2.5 mm <sup>2</sup> ) in the connection box passes by the built in M20 x 1.5 cable gland.			
<b>Elect. Power</b>	<b>DC</b>	<b>Pn (hot)</b>	8 W	
		<b>P (cold) 20°C</b>	9 W	
	<b>AC</b>	<b>Pn (holding)</b>	8 W	
		<b>Attraction cold</b>	9 W	
<b>Voltages "Un"</b>	<b>VAC/Hz</b>	<b>Code</b>	<b>VDC</b>	<b>Code</b>
-10% to +10% of Un for AC	24/50	<b>A2</b>	24	<b>C2</b>
-10% to +10% for Un DC	48/50	<b>A4</b>	48	<b>C4</b>
	115/50	<b>E5</b>	110	<b>C5</b>
	230/50	<b>F4</b>		

**To Order a Coil choose Coil Ref + Voltage Code, example: 495905 for 24 VDC = 495905C2**

\* 495905.05 available only in C4

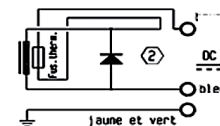
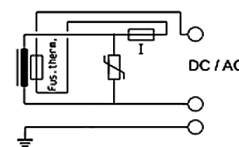
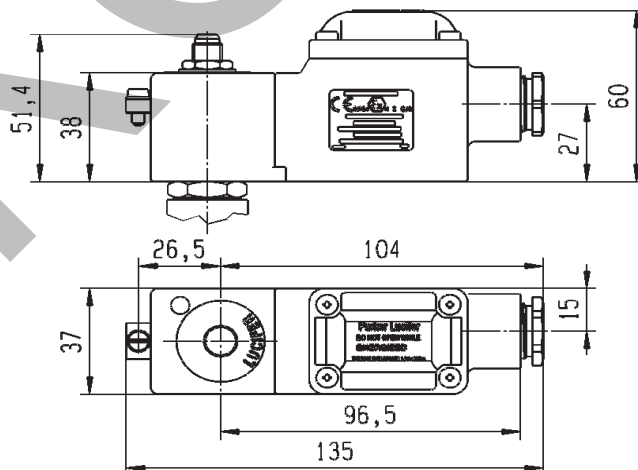

# Accessories

## Connector 2P + E DIN 43650 A

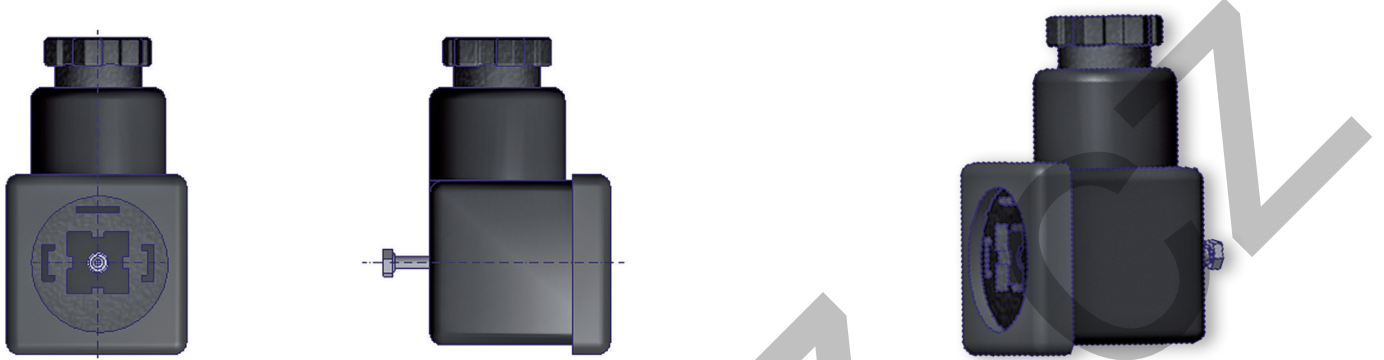

Drawing Reference N° 6

Max.A	Cable Section	Nominal Voltage	Description	Part Number	Drawing Reference
16 A	6-10 mm <sup>2</sup>	250 V AC/300 V DC	PG9-PG11 DIN Conn.-A182	486586	6

# Spare Parts

## Diaphragm Service Kit

This kit contains diaphragm only. Basing on port size of the valve and seals material required, please consult the table below. Spare part kit is the same for Normally open and Normally closed versions.

Valve Port Size BSPP or NPT	Description	Part Number	Diaphragm Material
3/8" - 1/2"	Diaphragm 7321B/7322B N 3/8"-1/2"	<b>306100SP</b>	NBR
	Diaphragm 7321B/7322B V 3/8"-1/2"	<b>306111SP</b>	FKM
	Diaphragm 7321B/7322B H 3/8" -1/2"	<b>306110SP</b>	EPDM
3/4" - 1"	Diaphragm 7321B/7322B N 3/4"-1"	<b>306120SP</b>	NBR
	Diaphragm 7321B/7322B V 3/4"-1"	<b>306131SP</b>	FKM
	Diaphragm 7321B/7322B H 3/4" - 1"	<b>306130SP</b>	EPDM
1 1/4" - 1 1/2"	Diaphragm 7321B/7322B N 1 1/4"-1 1/2"	<b>306133SP</b>	NBR
	Diaphragm 7321B/7322B H 1 1/4"-1 1/2"	<b>306138SP</b>	EPDM
2"	Diaphragm 7321B/7322B N 2"	<b>306140SP</b>	NBR
	Diaphragm 7321B/7322B H 2"	<b>306150SP</b>	EPDM
2 1/2" - 3"	Diaphragm 7321B/7322B N 2 1/2"-3"	<b>306156SP</b>	NBR

## Rebuild Service Kit

This kit contains diaphragm, sleeve, plungers and seals. Basing on function, port size and seals material required, please consult the table below. Spare part kit is not the same for Normally open and Normally closed versions.

Valve Port Size BSPP or NPT	Valve Function	Description	Part Number	Diaphragm Material
3/8" - 1/2"	NC	Rebuild Kit 7321B N - 3/8", 1/2", NBR	430088W	NBR
	NC	Rebuild Kit 7321B V - 3/8", 1/2", FKM	430090W	FKM
	NC	Rebuild Kit 7321B H - 3/8", 1/2", EPDM	430133W	EPDM
3/4" - 1"	NC	Rebuild Kit 7321B N - 3/4", 1", NBR	430089W	NBR
	NC	Rebuild Kit 7321B H - 1-1/4", 1-1/2", NBR	430095W	NBR
1 1/4" - 1 1/2"	NC	Rebuild Kit 7321B H - 1-1/4", 1-1/2", EPDM	430135W	EPDM
	NC	Rebuild Kit 7321B N - 2", NBR	430096W	NBR
2"	NC	Rebuild Kit 7321B H - 2", EPDM	430136W	EPDM
	NO	Rebuild Kit 7322B N - 3/8", 1/2", NBR	430137W	NBR
3/8" - 1/2"	NO	Rebuild Kit 7322B N - 3/4", 1", NBR	430138W	NBR
3/4" - 1"	NO	Rebuild Kit 7322B N - 1-1/4", 1-1/2", NBR	430139W	NBR
1 1/4" - 1 1/2"	NO	Rebuild Kit 7322B N - 2", NBR	430140W	NBR
2 1/2" - 3"	NO	Rebuild Kit 7322B N - 2", NBR		

# How to Order

**Pressure vessel and electrical parts included in this catalogue are available as stand-alone items and should be ordered separately.** The pressure vessel includes the housing (nameplate, nut and washer). Please consult your local sales office in case of demand for configured options.

## Step 1

Select the pressure vessel catalogue number (description) and/or part number at pages 6 to 12.

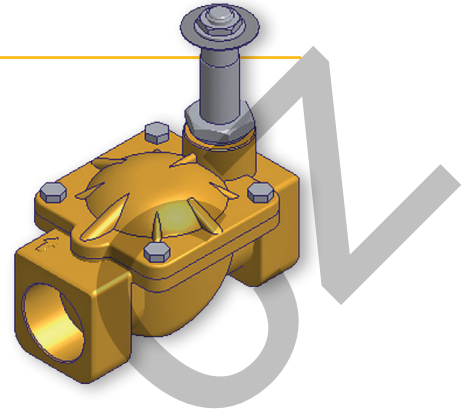

## Step 2

Please refer to the electrical group to determine the compatible coils on pages 13 to 17. Please follow the instructions included in each coil datasheet to determine the coil reference + voltage coil combination.

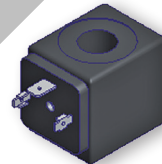

## Step 3

Select accessories on page 18.



### WARNING - USER RESPONSIBILITY

**FAILURE OR IMPROPER SELECTION OR IMPROPER USE OF THE PRODUCTS DESCRIBED HEREIN OR RELATED ITEMS CAN CAUSE DEATH, PERSONAL INJURY AND PROPERTY DAMAGE.**

- This document and other information from Parker-Hannifin Corporation, its subsidiaries and authorized distributors provide product or system options for further investigation by users having technical expertise.
- The user, through its own analysis and testing, is solely responsible for making the final selection of the system and components and assuring that all performance, endurance, maintenance, safety and warning requirements of the application are met. The user must analyze all aspects of the application, follow applicable industry standards, and follow the information concerning the product in the current product catalog and in any other materials provided from Parker or its subsidiaries or authorized distributors.
- To the extent that Parker or its subsidiaries or authorized distributors provide component or system options based upon data or specifications provided by the user, the user is responsible for determining that such data and specifications are suitable and sufficient for all applications and reasonably foreseeable uses of the components or systems.

# Parker's Motion & Control Technologies

At Parker, we're guided by a relentless drive to help our customers become more productive and achieve higher levels of profitability by engineering the best systems for their requirements. It means looking at customer applications from many angles to find new ways to create value. Whatever the motion and control technology need, Parker has the experience, breadth of product and global reach to consistently deliver. No company knows more about motion and control technology than Parker. For further info call 00800 27 27 5374.



## AEROSPACE

### Key Markets

- Aircraft engines
- Business & general aviation
- Commercial transports
- Land-based weapons systems
- Military aircraft
- Missiles & launch vehicles
- Regional transports
- Unmanned aerial vehicles

### Key Products

- Flight control systems & components
- Fluid conveyance systems
- Fluid metering delivery & atomization devices
- Fuel systems & components
- Hydraulic systems & components
- Inert nitrogen generating systems
- Pneumatic systems & components
- Wheels & brakes



## CLIMATE CONTROL

### Key Markets

- Agriculture
- Air conditioning
- Food, beverage & dairy
- Life sciences & medical
- Precision cooling
- Processing
- Transportation

### Key Products

- CO<sub>2</sub> controls
- Electronic controllers
- Filter driers
- Hand shut-off valves
- Hose & fittings
- Pressure regulating valves
- Refrigerant distributors
- Safety relief valves
- Solenoid valves
- Thermostatic expansion valves



## ELECTROMECHANICAL

### Key Markets

- Aerospace
- Factory automation
- Food & beverage
- Life science & medical
- Machine tools
- Packaging machinery
- Paper machinery
- Plastics machinery & converting
- Primary metals
- Semiconductor & electronics
- Textile
- Wire & cable

### Key Products

- AC/DC drives & systems
- Electric actuators
- Controllers
- Gantry robots
- Gearheads
- Human machine interfaces
- Industrial PCs
- Inverters
- Linear motors, slides and stages
- Precision stages
- Stepper motors
- Servo motors, drives & controls
- Structural extrusions



## FILTRATION

### Key Markets

- Food & beverage
- Industrial machinery
- Life sciences
- Marine
- Mobile equipment
- Oil & gas
- Power generation
- Process
- Transportation

### Key Products

- Analytical gas generators
- Compressed air & gas filters
- Condition monitoring
- Engine air, fuel & oil filtration & systems
- Hydraulic, lubrication & coolant filters
- Process, chemical, water & microfiltration filters
- Nitrogen, hydrogen & zero air generators



## FLUID & GAS HANDLING

### Key Markets

- Aerospace
- Agriculture
- Bulk chemical handling
- Construction machinery
- Food & beverage
- Fuel & gas delivery
- Industrial machinery
- Mobile
- Oil & gas
- Transportation
- Welding

### Key Products

- Brass fittings & valves
- Diagnostic equipment
- Fluid conveyance systems
- Industrial hose
- PTFE & PFA hose, tubing & plastic fittings
- Rubber & thermoplastic hose & couplings
- Tube fittings & adapters
- Quick disconnects



## HYDRAULICS

### Key Markets

- Aerospace
- Aerial lift
- Agriculture
- Construction machinery
- Forestry
- Industrial machinery
- Mining
- Oil & gas
- Power generation & energy
- Truck hydraulics

### Key Products

- Diagnostic equipment
- Hydraulic cylinders
- Hydraulic cylinders & accumulators
- Hydraulic motors & pumps
- Hydraulic systems
- Hydraulic valves & controls
- Power take-offs
- Rubber & thermoplastic hose & couplings
- Tube fittings & adapters
- Quick disconnects



## PNEUMATICS

### Key Markets

- Aerospace
- Conveyor & material handling
- Factory automation
- Food & beverage
- Life science & medical
- Machine tools
- Packaging machinery
- Transportation & automotive

### Key Products

- Air preparation
- Compact cylinders
- Field bus valve systems
- Grippers
- Guided cylinders
- Manifolds
- Miniature fluidics
- Pneumatic accessories
- Pneumatic actuators & grippers
- Pneumatic valves and controls
- Rodless cylinders
- Rotary actuators
- Tie rod cylinders
- Vacuum generators, cups & sensors



## PROCESS CONTROL

### Key Markets

- Chemical & refining
- Food, beverage & dairy
- Medical & dental
- Microelectronics
- Oil & gas
- Power generation

### Key Products

- Analytical sample conditioning products & systems
- Fluoropolymer chemical delivery fittings, valves & pumps
- High purity gas delivery fittings, valves & regulators
- Instrumentation fittings, valves & regulators
- Medium pressure fittings & valves
- Process control manifolds



## SEALING & SHIELDING

### Key Markets

- Aerospace
- Chemical processing
- Consumer
- Energy, oil & gas
- Fluid power
- General industrial
- Information technology
- Life sciences
- Military
- Semiconductor
- Telecommunications
- Transportation

### Key Products

- Dynamic seals
- Elastomeric o-rings
- EMI shielding
- Extruded & precision-cut, fabricated elastomeric seals
- Homogeneous & inserted elastomeric shapes
- High temperature metal seals
- Metal & plastic retained composite seals
- Thermal management



ENGINEERING YOUR SUCCESS.

KOVANZ.CZ

[www.parker.com](http://www.parker.com)



EMEA Product Information Centre  
Free phone: 00 800 27 27 5374 US  
Product Information Centre Toll-  
free number: 1-800-27 27 537  
[www.parker.com](http://www.parker.com)

Your authorized Distributor