

aerospace
climate control
electromechanical
filtration
fluid & gas handling
hydraulics
pneumatics
process control
sealing & shielding



Parker Angle Seat Valves

PA Series, 2/2 Way, NC or NO
3/8" to 2 1/2" BSP, 16 Bar



ENGINEERING YOUR SUCCESS.

Parker Angle Seat Valves

Introduction

An angle seat valve is actuated by a pneumatically driven piston and is capable to handle slurry solutions with particles or corrosive solutions at high temperature up to 180°C and operating pressure up to 16 Bar.

Benefits

- Compact design, high flow rates
- Visual position indicator
- For temperatures from -10°C to 180°C
- Working pressures up to 16 Bar
- Dampened closing anti-water hammer design (fluid under seat)
- Stainless Steel actuator housing for exceptional durability in steam and aggressive applications
- Valves meeting Pressure Equipment Directive 97/23/EC
- Mountable in any position
- Tight shut-off and Long Service Life
- Parker Angle Seat Valves conform to the terms of the 94/9/CE directive specific to non electrical equipment for use within potentially explosive environments - zones 1/21 and 2/22

Applications

Angle seat valves are suitable for many process and industrial applications:

- Food and Beverage Processing
- Water Technology & Treatment
- Textile Industry
- Cooling systems on injection molding machines
- Pharmaceutical & cosmetic industry
- Chemical Process technology
- Refrigeration & Cooling heat exchangers
- Sterilizers steam supply
- Water applications: Mining, Cement / Concrete Systems, Pulp & Paper
- General industrial applications of aggressive fluids
- Industrial Laundry Equipment
- Industrial Air Dryers



Table of Content

Key Features 04

General Specifications 05

Normally Closed
Flow Direction Over the Seat 06

Normally Open
Flow Direction Over the Seat 10

Normally Closed
Flow Direction Under the Seat
Anti Water Hammer Construction 11

Compact Design Normally Closed
Flow Direction Over Seat 13

Compact Design Normally Closed
Flow Direction Under Seat 14

Drawings and Dimensions 15

Numbering System 16

Solenoid Valves for Controlling
the PA Angle Seat Valves 17

Key Features

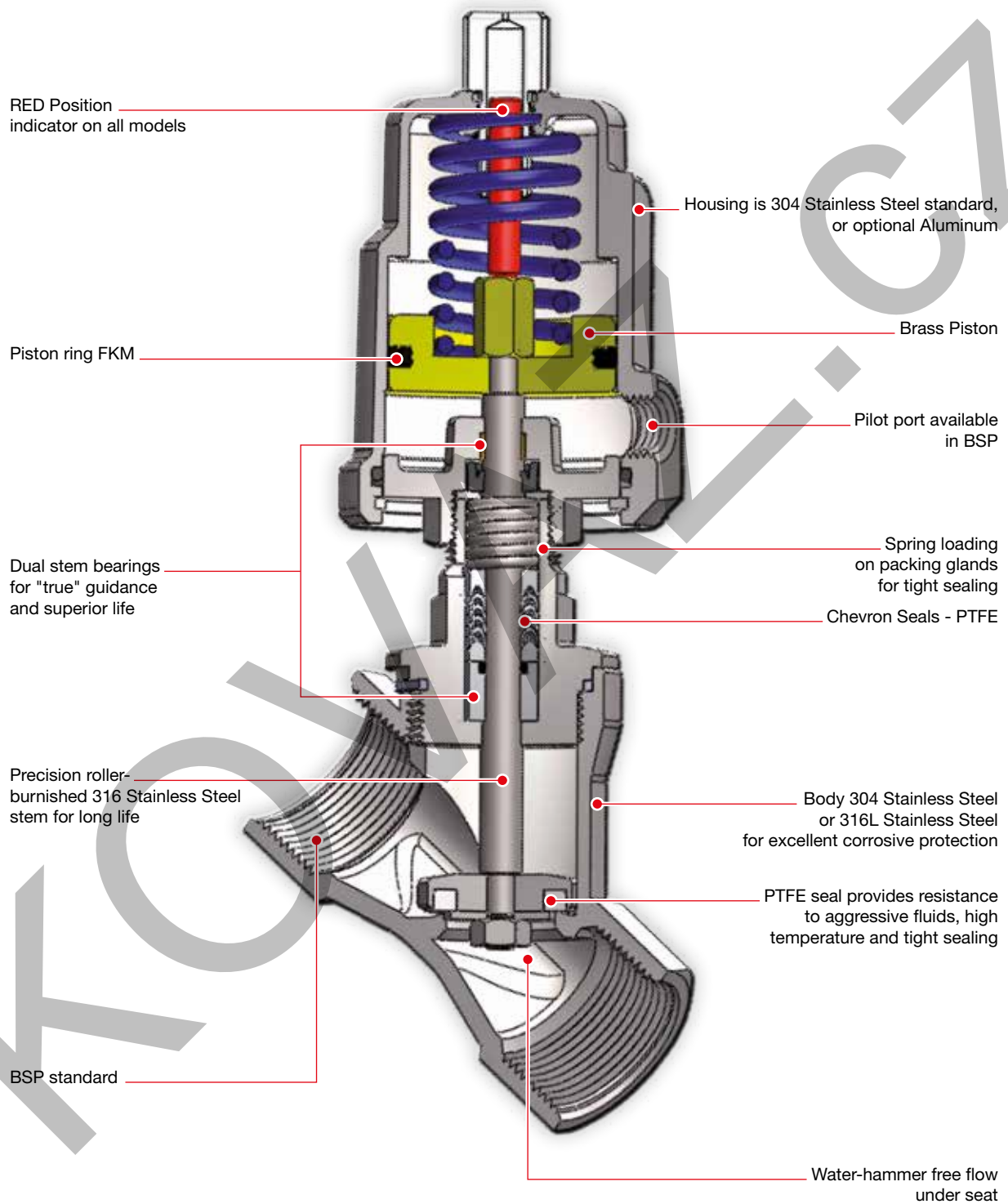

General Specifications

PA Series, 2/2 Way, NC or NO
3/8" to 2 1/2" BSP, 16 bar



- Body Material 304 Stainless Steel or 316 Stainless Steel
- Actuator Material 304 Stainless Steel, or Aluminum
- Function 2/2 NC, NO, NC (anti-water hammer)
- Port size from DN 10 (3/8") to DN 65 (2 1/2")
- Connections: Threads BSP
- Max Working Pressure 16 Bar
- Flow factor KV from 4.7 m³/h (DN10) to 70 m³/h (DN 65)
- The PA Series angle seat valves comply with European Pressure Equipment Directive 97/23/EC
- Parker Angle Seat Valves conform to the terms of the 94/9/CE directive specific to non electrical equipment for use within potentially explosive environments - Zones 1/21 and 2/22 - Protection II 2 GD c TX
- Pilot Pressure 3 Bar min to 10 Bar according to control pressure charts
- Maximum Fluid Temp -10°C to 180°C
- Ambient Temperature -10°C to 60°C
- Seat Seal material PTFE/RTFE
- Packing Gland: PTFE and PTFE with Carbon
- Installation Any Position
- Optical Position Indicator Standard on all sizes
- Pilot Control Media Air, Neutral Gas
- Fluids handled: Inert gases, hot water, oils, steam, aggressive and corrosive fluids
- Weight from 0.58 Kg (DN10) to 8.65 Kg (DN 65)
- Viscosity: Maxi. 600 mm²/s (600cSt, 80° E, 2700 SSU)

For liquids, use versions with flow direction under the seat.

Accessories

- Spare Parts Kits are available for main seat and body gasket replacement (on request)
- 3 Way Direct Acting AC & DC Pilot Control Valves available as separate components

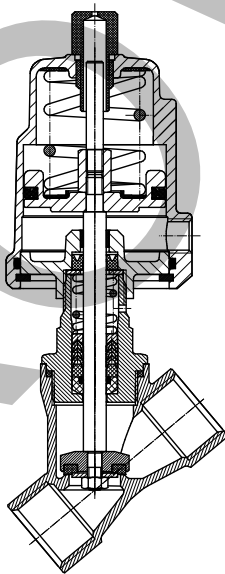

Normally Closed Valve

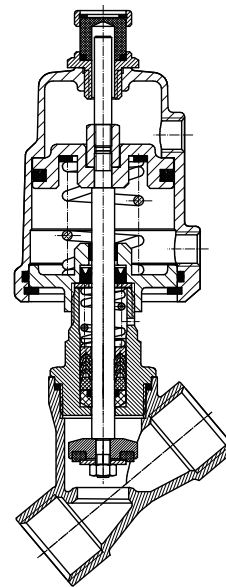

Normally Open Valve

PA Series - Normally Closed Valves Flow Direction **OVER** Seat



Model Numbers Shown are BSP threads

304 Stainless Steel Actuators
with 304 Stainless Steel Bodies



Size	Port Size	Orifice mm	Actuator mm	KV m ³ /h	Operating Pressure Differential bar	Minimum Pilot Control Pressure Range bar	Model Number	Net Weight Kg
DN10	3/8"	13	40	4.7	0-16	4	PA10S1G3S040S	0.78
			50	4.7	0-16	3	PA10S1G3S050S	1.01
DN15	1/2"	13	40	4.7	0-16	4	PA15S1G4S040S	0.80
			50	4.7	0-16	3	PA15S1G4S050S	1.03
DN20	3/4"	18	50	9.0	0-16	3-4	PA20S1G5S050S	1.06
DN25	1"	24	50	16.0	0-16	3-5.5	PA25S1G6S050S	1.38
			63	16.0	0-16	3-3.5	PA25S1G6S063S	2.05
DN32	1-1/4"	31	63	24.0	0-16	3-5	PA32S1G7S063S	2.40
DN40	1-1/2"	35	63	32.0	0-16	3-6	PA40S1G8S063S	2.75
			63	50.0	0-10	3-6.5	PA50S1G9S063S	3.50
DN50	2"	45	80	50.0	0-16	3-6.6	PA50S1G9S080S	4.62
			100	50.0	0-16	3-5	PA50S1G9S100S	5.16
DN65	2-1/2"	65	100	70.0	0-10	3-6	PA65S1GTS100S	8.65

304 Stainless Steel Actuators
with 316L Stainless Steel Bodies

Size	Port Size	Orifice mm	Actuator mm	KV m ³ /h	Operating Pressure Differential bar	Minimum Pilot Control Pressure Range bar	Model Number	Net Weight Kg
DN10	3/8"	13	40	4.7	0-16	4	PA10S1G3R040S	0.78
			50	4.7	0-16	3	PA10S1G3R050S	1.01
DN15	1/2"	13	40	4.7	0-16	4	PA15S1G4R040S	0.80
			50	4.7	0-16	3	PA15S1G4R050S	1.03
DN20	3/4"	18	50	9.0	0-16	3-4	PA20S1G5R050S	1.06
DN25	1"	24	50	16.0	0-16	3-5.5	PA25S1G6R050S	1.38
			63	16.0	0-16	3-3.5	PA25S1G6R063S	2.05
DN32	1-1/4"	31	63	24.0	0-16	3-5	PA32S1G7R063S	2.40
DN40	1-1/2"	35	63	32.0	0-16	3-6	PA40S1G8R063S	2.75
			63	50.0	0-10	3-6.5	PA50S1G9R063S	3.50
DN50	2"	45	80	50.0	0-16	3-6.6	PA50S1G9R080S	4.62
			100	50.0	0-16	3-5	PA50S1G9R100S	5.16
DN65	2-1/2"	65	100	70.0	0-10	3-6	PA65S1GTR100S	8.65

Control Pressure & Operating Pressure Charts for the Normally Closed Valves with 304 Stainless Steel Actuators

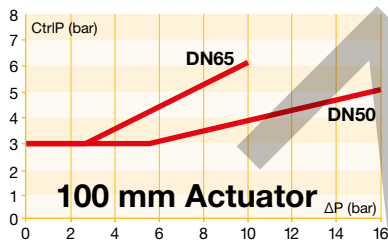
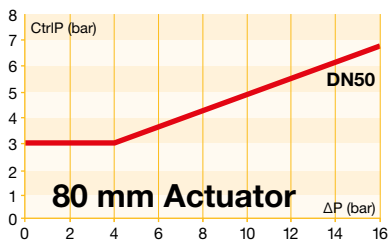
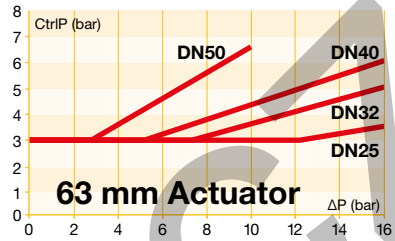
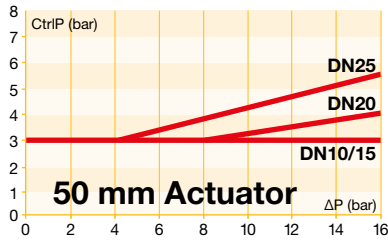
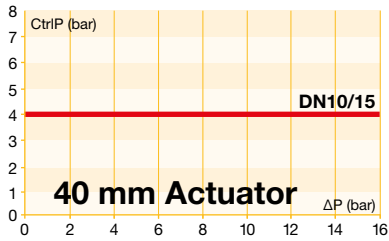

Flow Diagram

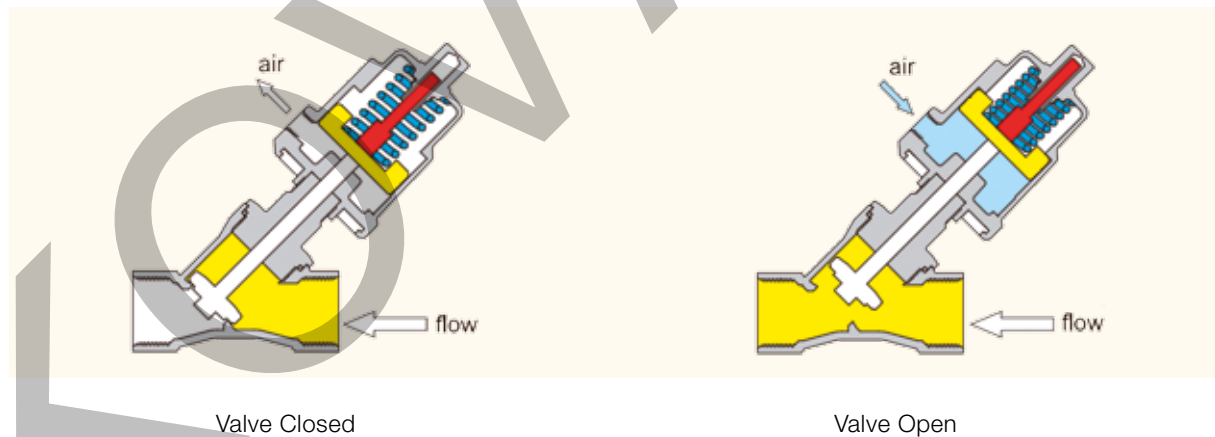

PA Series - Normally Closed Valves Flow Direction **OVER** Seat



Model Numbers Shown are BSP threads

Aluminium Actuators
with 304 Stainless Steel Bodies



Size	Port Size	Orifice mm	Actuator mm	KV m ³ /h	Operating Pressure Differential bar	Minimum Pilot Control Pressure Range bar	Model Number	Net Weight Kg
DN10	3/8"	13	50	4.7	0-16	3	PA10S1G3S050A	0.75
DN15	1/2"	13	50	4.7	0-16	3	PA15S1G4S050A	0.80
DN20	3/4"	18	50	9.0	0-16	3-4	PA20S1G5S050A	0.90
DN25	1"	24	50	16.0	0-16	3-5.5	PA25S1G6S050A	1.27
			63	16.0	0-16	3-4	PA25S1G6S063A	1.65
DN32	1-1/4"	31	63	24.0	0-16	3-5.5	PA32S1G7S063A	1.89
DN40	1-1/2"	35	63	32.0	0-16	3-6.5	PA40S1G8S063A	2.15
			63	50.0	0-10	3-6.5	PA50S1G9S063A	2.98
			80	50.0	0-16	3-6.6	PA50S1G9S080A	3.56
DN50	2"	45	100	50.0	0-16	3-5	PA50S1G9S100A	4.75
			100	70.0	0-10	3-6	PA65S1GTS100A	5.50

Aluminium Actuators
with 316L Stainless Steel Bodies

Size	Port Size	Orifice mm	Actuator mm	KV m ³ /h	Operating Pressure Differential bar	Minimum Pilot Control Pressure Range bar	Model Number	Net Weight Kg
DN10	3/8"	13	50	4.7	0-16	3	PA10S1G3R050A	0.75
DN15	1/2"	13	50	4.7	0-16	3	PA15S1G4R050A	0.80
DN20	3/4"	18	50	9.0	0-16	3-4	PA20S1G5R050A	0.90
DN25	1"	24	50	16.0	0-16	3-5.5	PA25S1G6R050A	1.27
			63	16.0	0-16	3-4	PA25S1G6R063A	1.65
DN32	1-1/4"	31	63	24.0	0-16	3-5.5	PA32S1G7R063A	1.89
DN40	1-1/2"	35	63	32.0	0-16	3-6.5	PA40S1G8R063A	2.15
			63	50.0	0-10	3-6.5	PA50S1G9R063A	2.98
			80	50.0	0-16	3-6.6	PA50S1G9R080A	3.56
DN50	2"	45	100	50.0	0-16	3-5	PA50S1G9R100A	4.75
			100	70.0	0-10	3-6	PA65S1GTR100A	5.50

Control Pressure & Operating Pressure Charts for the Normally Closed Valves with Aluminum Actuators

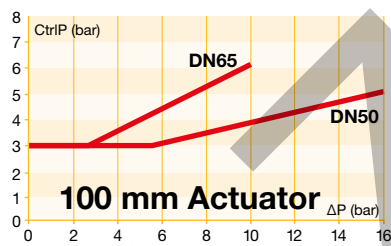
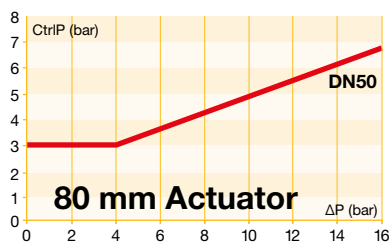
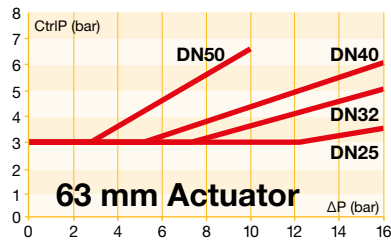
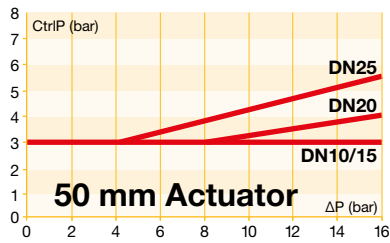

Flow Diagram

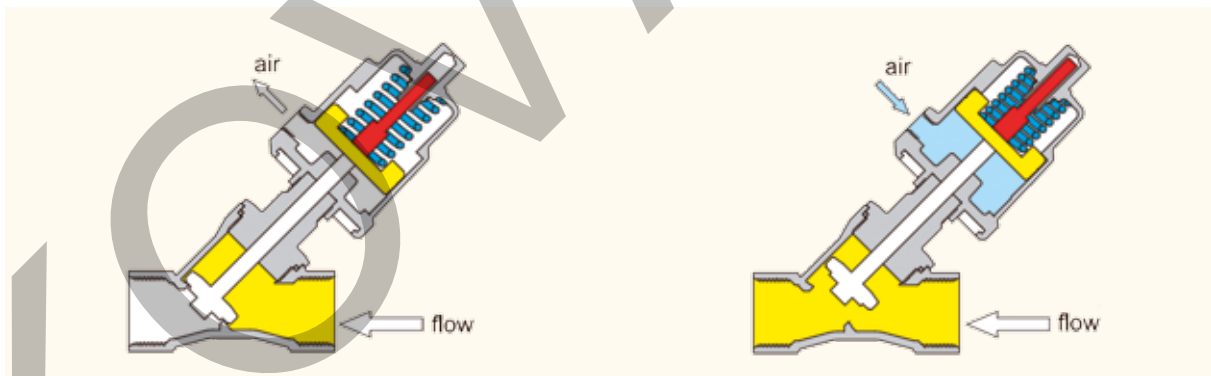

Valve Closed

Valve Open

PA Series - Normally Open Valves Flow Direction OVER Seat



Model Numbers Shown are BSP threads

304 Stainless Steel Actuators
with 304 Stainless Steel Bodies



Size	Port Size	Orifice mm	Actuator mm	KV m ³ /h	Operating Pressure Differential bar	Minimum Pilot Control Pressure bar	Model Number	Net Weight Kg
DN10	3/8"	13	50	4.7	0-16	3.5	PA10S2G3S050S	1.00
DN15	1/2"	13	50	4.7	0-16	3.5	PA15S2G4S050S	1.03
DN20	3/4"	18	50	9.0	0-16	3.5	PA20S2G5S050S	1.06
DN25	1"	24	63	16.0	0-16	4.5	PA25S2G6S063S	2.05
DN32	1-1/4"	31	63	24.0	0-14	4.5	PA32S2G7S063S	2.40
DN40	1-1/2"	35	63	32.0	0-11	4.5	PA40S2G8S063S	2.75
DN50	2"	45	63	50.0	0-6	5	PA50S2G9S063S	3.50
			80	50.0	0-12	5	PA50S2G9S080S	4.62

304 Stainless Steel Actuators
with 316L Stainless Steel Bodies

Size	Port Size	Orifice mm	Actuator mm	KV m ³ /h	Operating Pressure Differential bar	Minimum Pilot Control Pressure bar	Model Number	Net Weight Kg
DN10	3/8"	13	50	4.7	0-16	3.5	PA10S2G3R050S	1.00
DN15	1/2"	13	50	4.7	0-16	3.5	PA15S2G4R050S	1.03
DN20	3/4"	18	50	9.0	0-16	3.5	PA20S2G5R050S	1.06
DN25	1"	24	63	16.0	0-16	4.5	PA25S2G6R063S	2.05
DN32	1-1/4"	31	63	24.0	0-14	4.5	PA32S2G7R063S	2.40
DN40	1-1/2"	35	63	32.0	0-11	4.5	PA40S2G8R063S	2.75
DN50	2"	45	63	50.0	0-6	5	PA50S2G9R063S	3.50
			80	50.0	0-12	5	PA50S2G9R080S	4.62

Control Pressure & Operating Pressure

Charts do not apply for Normally Open Valves. A minimum pressure as noted above is all that is required, up to 10 bar Maximum.

Flow Diagram

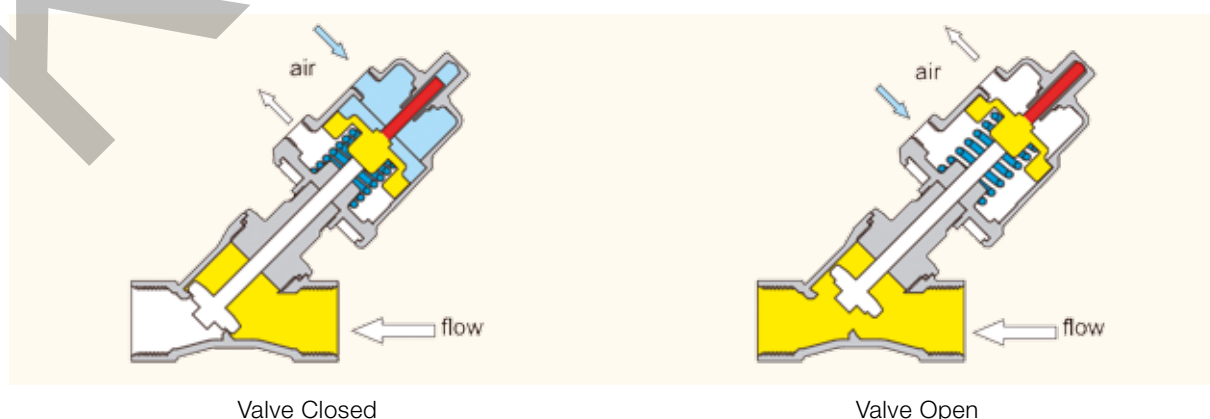

PA Series - Normally Closed Valves

Flow Direction UNDER Seat

Anti Water Hammer Construction

Model Numbers Shown are BSP threads

304 Stainless Steel Actuators
with 304 Stainless Steel Bodies



Size	Port Size	Orifice mm	Actuator mm	KV m ³ /h	Operating Pressure Differential bar	Minimum Pilot Control Pressure bar	Model Number	Net Weight Kg
DN10	3/8"	13	50	4.7	0-16	4.5	PA10SAG3S050S	1.01
DN15	1/2"	13	50	4.7	0-16	4.5	PA15SAG4S050S	1.03
DN20	3/4"	18	50	9.0	0-10	4.5	PA20SAG5S050S	1.06
DN25	1"	24	63	16.0	0-8	4.5	PA25SAG6S063S	2.05
DN32	1-1/4"	31	80	24.0	0-11	4	PA32SAG7S080S	3.82
DN40	1-1/2"	35	80	32.0	0-8	4	PA40SAG8S080S	4.07
			100	32.0	0-16	4	PA40SAG8S100S	4.61
DN50	2"	45	100	50.0	0-9	4	PA50SAG9S100S	5.16

304 Stainless Steel Actuators
with 316L Stainless Steel Bodies

Size	Port Size	Orifice mm	Actuator mm	KV m ³ /h	Operating Pressure Differential bar	Minimum Pilot Control Pressure bar	Model Number	Net Weight Kg
DN10	3/8"	13	50	4.7	0-16	4.5	PA10SAG3R050S	1.01
DN15	1/2"	13	50	4.7	0-16	4.5	PA15SAG4R050S	1.03
DN20	3/4"	18	50	9.0	0-10	4.5	PA20SAG5R050S	1.06
DN25	1"	24	63	16.0	0-8	4.5	PA25SAG6R063S	2.05
DN32	1-1/4"	31	80	24.0	0-11	4	PA32SAG7R080S	3.82
DN40	1-1/2"	35	80	32.0	0-8	4	PA40SAG8R080S	4.07
			100	32.0	0-16	4	PA40SAG8R100S	4.61
DN50	2"	45	100	50.0	0-9	4	PA50SAG9R100S	5.16

Flow Diagram

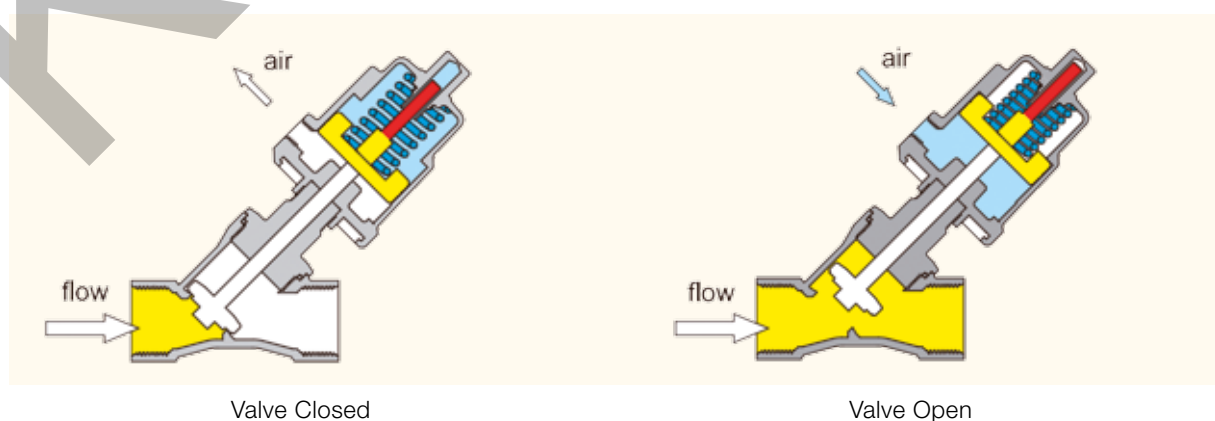

PA Series - Normally Closed Valves Flow Direction UNDER Seat

Anti Water Hammer Construction

Model Numbers Shown are BSP threads



Aluminum Actuators
with 304 Stainless Steel Bodies



Size	Port Size	Orifice mm	Actuator mm	KV m ³ /h	Operating Pressure Differential bar	Minimum Pilot Control Pressure bar	Model Number	Net Weight Kg
DN10	3/8"	13	50	4.7	0-16	4.5	PA10SAG3S050A	0.75
DN15	1/2"	13	50	4.7	0-16	4.5	PA15SAG4S050A	0.80
DN20	3/4"	18	50	9.0	0-10	4.5	PA20SAG5S050A	0.90
DN25	1"	24	63	16.0	0-8	4.5	PA25SAG6S063A	1.65
DN32	1-1/4"	31	80	24.0	0-11	4	PA32SAG7S080A	2.80
			80	32.0	0-8	4	PA40SAG8S080A	3.10
DN40	1-1/2"	35	100	32.0	0-16	4	PA40SAG8S100A	4.15
			100	50.0	0-9	4	PA50SAG9S100A	4.75

Aluminum Actuators with 316L Stainless Steel Bodies

Size	Port Size	Orifice mm	Actuator mm	KV m ³ /h	Operating Pressure Differential bar	Minimum Pilot Control Pressure bar	Model Number	Net Weight Kg
DN10	3/8"	13	50	4.7	0-16	4.5	PA10SAG3R050A	0.75
DN15	1/2"	13	50	4.7	0-16	4.5	PA15SAG4R050A	0.80
DN20	3/4"	18	50	9.0	0-10	4.5	PA20SAG5R050A	0.90
DN25	1"	24	63	16.0	0-8	4.5	PA25SAG6R063A	1.65
DN32	1-1/4"	31	80	24.0	0-11	4	PA32SAG7R080A	2.80
			80	32.0	0-8	4	PA40SAG8R080A	3.10
DN40	1-1/2"	35	100	32.0	0-16	4	PA40SAG8R100A	4.15
			100	50.0	0-9	4	PA50SAG9R100A	4.75

Control Pressure & Operating Pressure

Charts do not apply for Valves with flow direction Under Seat. A minimum pressure as noted above is all that is required, up to a maximum of 10 bar.

Flow Diagram

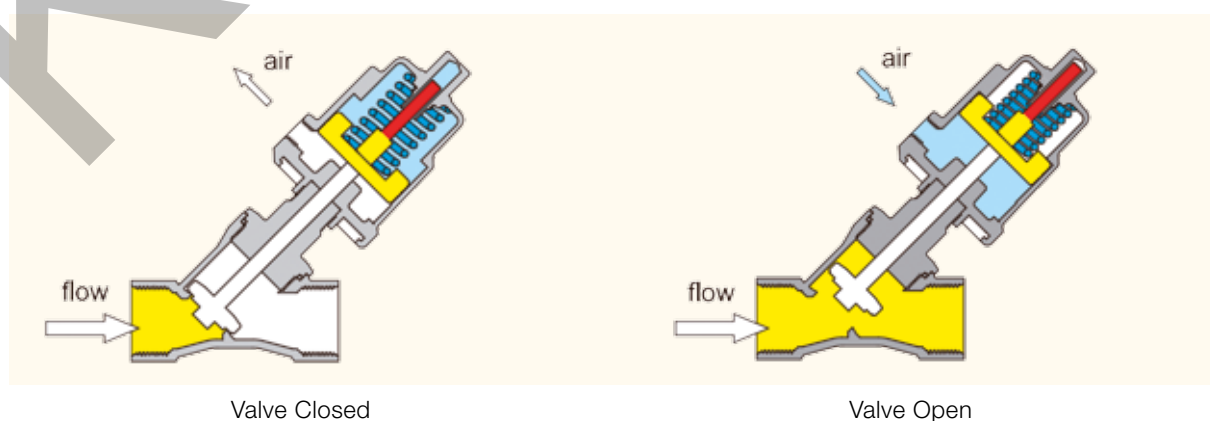

PA Series - Compact Design Normally Closed Valves-Flow direction OVER Seat



Model Numbers Shown are BSP threads

Media Temperature - 10°C to + 100°C



304 Stainless Steel Actuators with 304 Stainless Steel Bodies

Size	Port Size	Orifice mm	Actuator mm	KV m ³ /h	Operating Pressure Differential bar	Minimum Pilot Control Pressure Range bar	Model Number	Net Weight Kg
DN10	3/8"	13	32	4.7	0-16	4.5-6	PA10C3G3S032S	0.58
DN15	1/2"	13	32	4.7	0-16	4.5-6	PA15C3G4S032S	0.60
DN20	3/4"	15	32	5.4	0-14	4.5-6	PA20C3G5S032S	0.65

304 Stainless Steel Actuators with 316L Stainless Steel Bodies

Size	Port Size	Orifice mm	Actuator mm	KV m ³ /h	Operating Pressure Differential bar	Minimum Pilot Control Pressure Range bar	Model Number	Net Weight Kg
DN10	3/8"	13	32	4.7	0-16	4.5-6	PA10C3G3R032S	0.58
DN15	1/2"	13	32	4.7	0-16	4.5-6	PA15C3G4R032S	0.60
DN20	3/4"	15	32	5.4	0-14	4.5-6	PA20C3G5R032S	0.65

Media Temperature - 10°C to + 180°C

304 Stainless Steel Actuators with 304 Stainless Steel Bodies

Size	Port Size	Orifice mm	Actuator mm	KV m ³ /h	Operating Pressure Differential bar	Minimum Pilot Control Pressure Range bar	Model Number	Net Weight Kg
DN10	3/8"	13	32	4.7	0-16	4.5-6	PA10C1G3S032S	0.63
DN15	1/2"	13	32	4.7	0-16	4.5-6	PA15C1G4S032S	0.65
DN20	3/4"	15	32	5.4	0-14	4.5-6	PA20C1G5S032S	0.71

304 Stainless Steel Actuators with 316L Stainless Steel Bodies

Size	Port Size	Orifice mm	Actuator mm	KV m ³ /h	Operating Pressure Differential bar	Minimum Pilot Control Pressure Range bar	Model Number	Net Weight Kg
DN10	3/8"	13	32	4.7	0-16	4.5-6	PA10C1G3R032S	0.63
DN15	1/2"	13	32	4.7	0-16	4.5-6	PA15C1G4R032S	0.65
DN20	3/4"	15	32	5.4	0-14	4.5-6	PA20C1G5R032S	0.71

Control Pressure & Operating Pressure

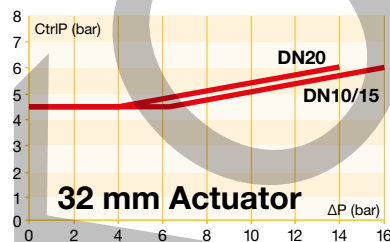

Flow Diagram

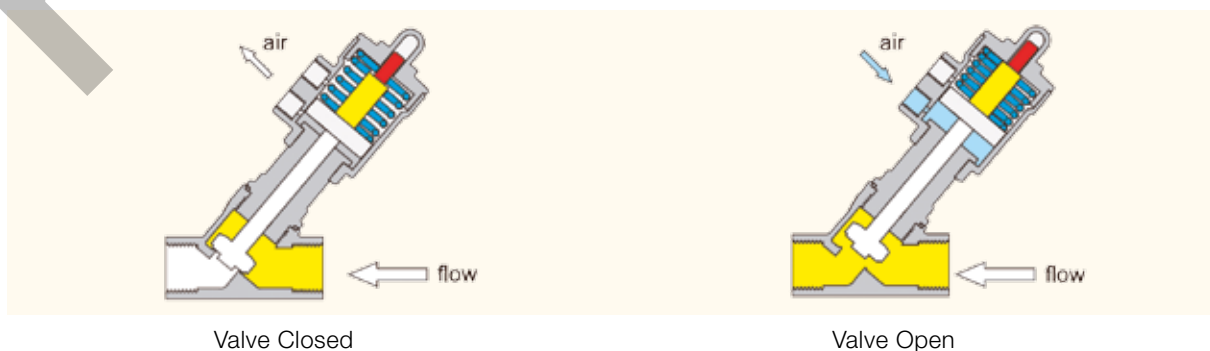

PA Series - Drawings and Dimensions

Stainless Steel Actuators Sizes 40, 50, 63, 80, 100 mm

Type	Actuator	D	R	P	K1	A1	G	L	T	SW
DN10	40	50.5	27	G1/8	116	121	G3/8	60	10	22 hexagon
	50	62	34	G1/8	130	133	G3/8	60	10	22 hexagon
DN15	40	50.5	27	G1/8	118	124	G1/2	65	11.5	25 hexagon
	50	62	34	G1/8	131	135	G1/2	65	11.5	25 hexagon
DN 20	50	62	34	G1/8	134	141	G3/4	75	14	31 hexagon
DN25	50	62	34	G1/8	141	153	G1	90	15	39 hexagon
	63	77	41.5	G1/8	164	175	G1	90	15	39 hexagon
DN32	63	77	41.5	G1/8	170	188	G1-1/4	110	18	50 octagon
	80	98	52	G1/4	184	205	G1-1/4	110	18	50 octagon
DN40	63	77	41.5	G1/8	181	201	G1-1/2	120	18	56 octagon
	80	98	52	G1/4	195	217	G1-1/2	120	18	56 octagon
DN50	100	121	63	G1/4	213	235	G1-1/2	120	18	56 octagon
	63	77	41.5	G1/8	189	216	G2	150	22	68 octagon
DN65	80	98	52	G1/4	203	233	G2	150	22	68 octagon
	100	121	63	G1/4	221	250	G2	150	22	68 octagon

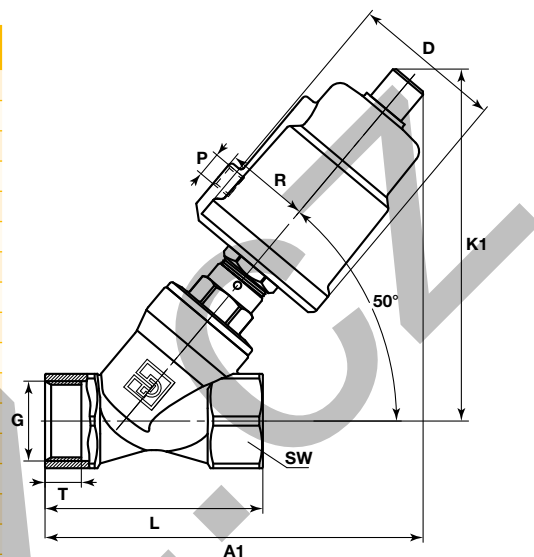

Aluminum Actuators Sizes 50, 63, 80, 100 mm

Type	Actuator	D	R	P	K1	A1	G	L	T	SW
DN10	50	61	38	G1/8	132	141	G3/8	60	10	22 hexagon
DN15	50	61	38	G1/8	133	144	G1/2	65	11.5	25 hexagon
DN20	50	61	38	G1/8	136	150	G3/4	75	14	31 hexagon
DN25	50	61	38	G1/8	144	162	G1	90	15	39 hexagon
	63	75	45	G1/8	167	183	G1	90	15	39 hexagon
DN32	63	75	45	G1/8	173	196	G1-1/4	110	18	50 octagon
	80	94	54	G1/4	192	214	G1-1/4	110	18	50 octagon
DN40	63	75	45	G1/8	184	209	G1-1/2	120	18	56 octagon
	80	94	54	G1/4	203	226	G1-1/2	120	18	56 octagon
DN50	100	115	64	G1/4	223	245	G1-1/2	120	18	56 octagon
	63	75	45	G1/8	192	224	G2	150	22	68 octagon
DN65	80	94	54	G1/4	211	242	G2	150	22	68 octagon
	100	115	64	G1/4	231	260	G2	150	22	68 octagon

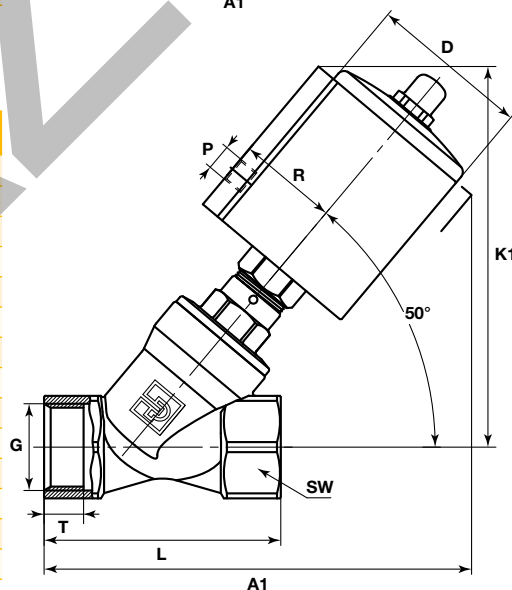

Stainless Steel Actuators Size 32 mm

Type	Actuator	Ø B	R	G1	K2		A2		G	L	T	SW
					Type C1/C2 (180°C)	Type C3/C4 (100°C)	Type C1/C2 (180°C)	Type C3/C4 (100°C)				
DN10	32	39.6	27	G1/8	107	94	117	106	G3/8	60	10	22 hexagon
DN15	32	39.6	27	G1/8	109	96	119	108	G1/2	65	11.5	25 hexagon
DN20	32	39.6	27	G1/8	112	100	126	115	G3/4	75	14	31 hexagon

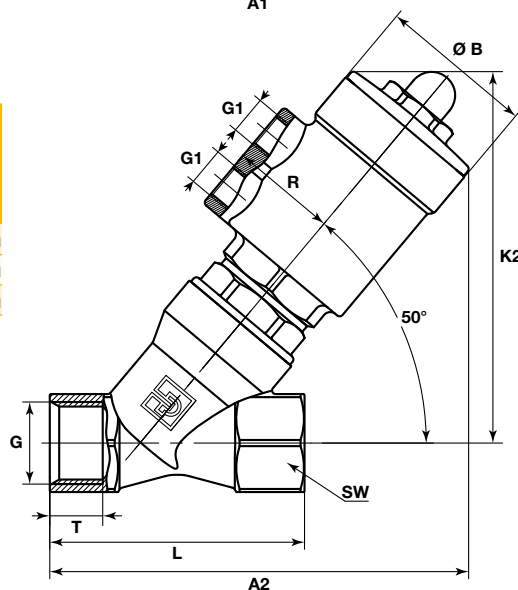

PA Series - Numbering System

Angle Seat Valve Numbering System

PA	10		S1		G3			S	063S		-
	Valve Size		Valve Type/Series		Body Thread Standard			Body Material	Actuator Description		Special
PA	10	DN10	S1	NC	G3	3/8	BSP	S	304 SS		Stainless Steel 304
PA	15	DN15	S2	NO	G4	1/2	BSP	R	316L SS		032S 32 mm actuator
PA	20	DN20	SA	NC, flow under seat	G5	3/4	BSP				040S 40 mm actuator
PA	25	DN25	C1	Compact, NC, flow over seat	G6	1	BSP				050S 50 mm actuator
PA	32	DN32	C2	Compact, NC, flow under seat	G7	1-1/4	BSP				063S 63 mm actuator
PA	40	DN40	C3	Compact NC, flow over seat (100°C)	G8	1-1/2	BSP				080S 80 mm actuator
PA	50	DN50	C4	Compact NC, flow under seat (100°C)	G9	2	BSP				100S 100 mm actuator
PA	65	DN65			GT	2-1/2	BSP				
											Aluminum
											040A 40 mm actuator
											050A 50 mm actuator
											063A 63 mm actuator
											080A 80 mm actuator
											100A 100 mm actuator



WARNING - USER RESPONSIBILITY

FAILURE OR IMPROPER SELECTION OR IMPROPER USE OF THE PRODUCTS DESCRIBED HEREIN OR RELATED ITEMS CAN CAUSE DEATH, PERSONAL INJURY AND PROPERTY DAMAGE.

- This document and other information from Parker-Hannifin Corporation, its subsidiaries and authorized distributors provide product or system options for further investigation by users having technical expertise.
- The user, through its own analysis and testing, is solely responsible for making the final selection of the system and components and assuring that all performance, endurance, maintenance, safety and warning requirements of the application are met. The user must analyze all aspects of the application, follow applicable industry standards, and follow the information concerning the product in the current product catalog and in any other materials provided from Parker or its subsidiaries or authorized distributors.
- To the extent that Parker or its subsidiaries or authorized distributors provide component or system options based upon data or specifications provided by the user, the user is responsible for determining that such data and specifications are suitable and sufficient for all applications and reasonably foreseeable uses of the components or systems.

Solenoid Valves for Controlling the PA Angle Seat Valves

3 Way Direct Acting Pilot Control Valves

Available as Separate Components

Features

- Compact designs
- Brass or Stainless steel body valves
- NC (normally closed) and NO (normally open) versions
- Broad offering of coils to meet World Wide requirements
- Available in BSP and NPT connections in 1/8" and 1/4" sizes

Representative Pictures

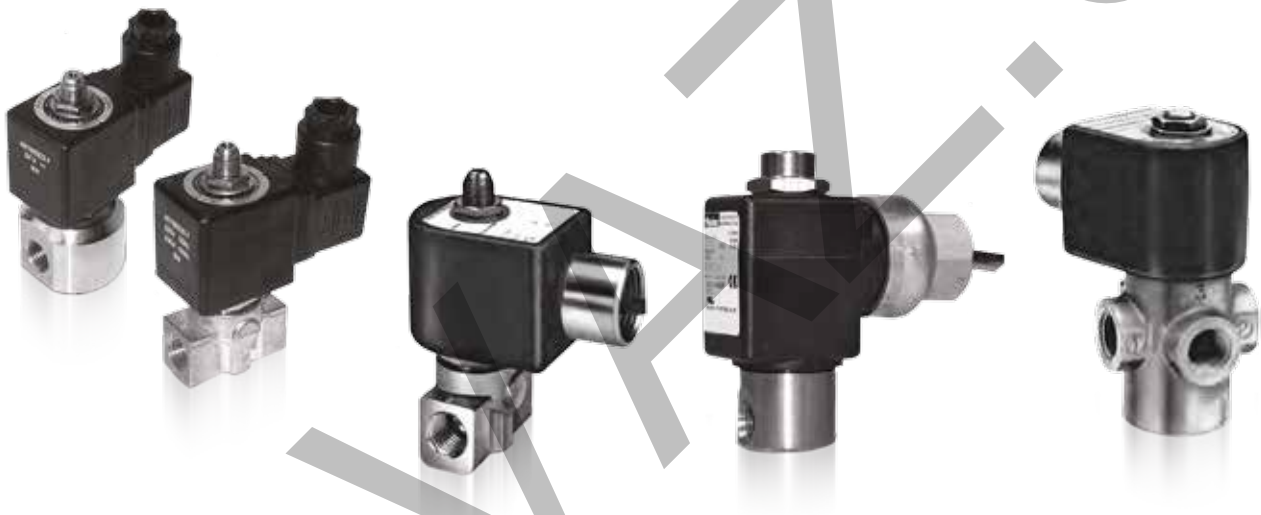

Banjo Valve for Direct Mounting to the Valve



Banjo Valve



Banjo Valve Mounted to the valve

Solenoid Valves for Controlling the PA Angle Seat Valves

3 Way Direct Acting Pilot Control Valves

Banjo Valve - Available as Separate Components

Banjo Valves G1/4" & G1/8" Series with Aluminium Body

Solenoid Operated Versions - B14-B04 Versions with 22 mm Coil

Port Size	Orifice	Q _N	Admissible differential pressure (bar) max.			Max. admissible fluid temperature (°C) Min. = -10°C	Seat disc	Reference number			Consumption Power (Watt)		Weight (g)	Dim. Ref.
			min	DC=	AC~			Air & Neutral gases	Valve	Housing	Coil	DC		
Banjo	G	mm	l/min											

3/2 Solenoid operated - Spring return (monostable)

1/8	1/8	1.2	50	0	10	10	50	NBR	131B14	-	496131	3	3	140	26
1/8	1/8	1.2	50	0	10	10	50	NBR	131B14	-	496482	3	3	150	26
1/8	1/8	1.2	50	0	10	10	50	NBR	131B14	-	496637	3	3	150	26
1/8	1/8	1.2	50	0	10	-	50	NBR	131B14	-	482605	5	-	170	26

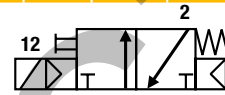

3/2 Solenoid operated - Spring return (monostable)

1/4	1/8	1.2	50	0	10	10	50	NBR	131B04	-	496131	3	3	160	27
1/4	1/8	1.2	50	0	10	10	50	NBR	131B04	-	496482	3	3	175	27
1/4	1/8	1.2	50	0	10	10	50	NBR	131B04	-	496637	3	3	175	27
1/4	1/8	1.2	50	0	10	-	50	NBR	131B04	-	482605	5	-	190	27

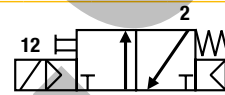

Dimensions Reference 26

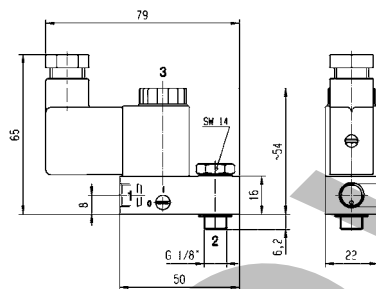

Dimensions Reference 27

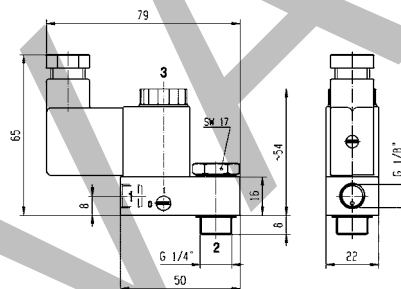

Coils 22 mm for Banjo Valves Series

These coils with connection for 2 P+G DIN 43650 B plug are encapsulated in synthetic material, conform to the IEC/CENELEC safety standards and comply with European low voltage directive 2006/95/EC. Banjo Valve bodies conform to the terms of the directive 94/9/CE specific to non electrical equipment for use within potentially explosive environments - Please select appropriate Coil for Safe Area or ATEX zones 1/21 or 2/22 in the following table.

- Power: 3 W or 5 W
- Insulation Class: F (155°C)
- Degree of Protection: IP65 (with plug)
- Duty Cycle: 100% ED

Available Voltages	Safe area without DIN plug Code	Safe area with DIN plug Code	For Zone 2/22 II 3 G-Ex nc AC IIC T5 II 3 D-Ex tc AC IIC - T 95°C code with DIN plug	For Zone 1/21 II 2 G-Ex mb II T4 II 2 D-Ex tb IIC - T 130°C code includes DIN plug and 1.5 m cable
12 VDC	496131 C1	496482 C1	496637 C1	482605 C1
24 VDC	496131 C2	496482 C2	496637 C2	482605 C2
48 VDC	496131 C4	496482 C4	496637 C4	-
110 VDC	496131 C5	496482 C5	496637 C5	-
24/50-60 VAC	496131 P0	496482 P0	496637 P0	-
48/50-60 VAC	496131 S4	496482 S4	496637 S4	-
110/50-60 VAC	496131 P2	496482 P2	496637 P2	-
115/60 VAC	496131 K8	496482 K8	496637 K8	-
230/50-60 VAC	496131 P9	496482 P9	496637 P9	-

How to Order

Valve Reference Number - Coil Reference - Voltage code = Order code

Example: 131B14 - 496131 C2 - Valves and coils may be ordered also separately.



Parker's Motion & Control Technologies

At Parker, we're guided by a relentless drive to help our customers become more productive and achieve higher levels of profitability by engineering the best systems for their requirements. It means looking at customer applications from many angles to find new ways to create value. Whatever the motion and control technology need, Parker has the experience, breadth of product and global reach to consistently deliver. No company knows more about motion and control technology than Parker. For further info call 00800 27 27 5374



Aerospace Key Markets

- Aftermarket services
- Commercial transports
- Engines
- General & business aviation
- Helicopters
- Launch vehicles
- Military aircraft
- Missiles
- Power generation
- Regional transports
- Unmanned aerial vehicles

Key Products

- Control systems & actuation products
- Engine systems & components
- Fluid conveyance systems & components
- Fluid metering, delivery & atomization devices
- Fuel systems & components
- Fuel tank inerting systems
- Hydraulic systems & components
- Thermal management
- Wheels & brakes



Climate Control Key Markets

- Agriculture
- Air conditioning
- Construction Machinery
- Food & beverage
- Industrial machinery
- Life sciences
- Oil & gas
- Precision cooling
- Process
- Refrigeration
- Transportation

Key Products

- Accumulators
- Advanced actuators
- CO₂ controls
- Electronic controllers
- Filter driers
- Hand shut-off valves
- Heat exchangers
- Hose & fittings
- Pressure regulating valves
- Refrigerant distributors
- Safety relief valves
- Smart pumps
- Solenoid valves
- Thermostatic expansion valves



Electromechanical Key Markets

- Aerospace
- Factory automation
- Life science & medical
- Machine tools
- Packaging machinery
- Paper machinery
- Plastics machinery & converting
- Primary metals
- Semiconductor & electronics
- Textile
- Wire & cable

Key Products

- AC/DC drives & systems
- Electric actuators, gantry robots & slides
- Electrohydraulic actuation systems
- Electromechanical actuation systems
- Human machine interface
- Linear motors
- Stepper motors, servo motors, drives & controls
- Structural extrusions



Filtration Key Markets

- Aerospace
- Food & beverage
- Industrial plant & equipment
- Life sciences
- Marine
- Mobile equipment
- Oil & gas
- Power generation & renewable energy
- Process
- Transportation
- Water Purification

Key Products

- Analytical gas generators
- Compressed air filters & dryers
- Engine air, coolant, fuel & oil filtration systems
- Fluid condition monitoring systems
- Hydraulic & lubrication filters
- Hydrogen, nitrogen & zero air generators
- Instrumentation filters
- Membrane & fiber filters
- Microfiltration
- Sterile air filtration
- Water desalination & purification filters & system



Fluid & Gas Handling Key Markets

- Aerial lift
- Agriculture
- Bulk chemical handling
- Construction machinery
- Food & beverage
- Fuel & gas delivery
- Industrial machinery
- Life sciences
- Marine
- Mining
- Mobile
- Oil & gas
- Renewable energy
- Transportation

Key Products

- Check valves
- Connectors for low pressure fluid conveyance
- Deep sea umbilicals
- Diagnostic equipment
- Hose couplings
- Industrial hose
- Mooring systems & power cables
- PTFE hose & tubing
- Quick couplings
- Rubber & thermoplastic hose
- Tube fittings & adapters
- Tubing & plastic fittings



Hydraulics Key Markets

- Aerial lift
- Agriculture
- Alternative energy
- Construction machinery
- Forestry
- Industrial machinery
- Machine tools
- Marine
- Material handling
- Mining
- Oil & gas
- Power generation
- Refuse vehicles
- Renewable energy
- Truck hydraulics
- Turf equipment

Key Products

- Accumulators
- Cartridge valves
- Electrohydraulic actuators
- Human machine interfaces
- Hybrid drives
- Hydraulic cylinders
- Hydraulic motors & pumps
- Hydraulic systems
- Hydraulic valves & controls
- Hydrostatic steering
- Integrated hydraulic circuits
- Power take-offs
- Power units
- Rotary actuators
- Sensors



Pneumatics Key Markets

- Aerospace
- Conveyor & material handling
- Factory automation
- Life science & medical
- Machine tools
- Packaging machinery
- Transportation & automotive

Key Products

- Air preparation
- Brass fittings & valves
- Manifolds
- Pneumatic accessories
- Pneumatic actuators & grippers
- Pneumatic valves & controls
- Quick disconnects
- Rotary actuators
- Rubber & thermoplastic hose & couplings
- Structural extrusions
- Thermoplastic tubing & fittings
- Vacuum generators, cups & sensors



Process Control Key Markets

- Alternative fuels
- Biopharmaceuticals
- Chemical & refining
- Food & beverage
- Marine & shipbuilding
- Medical & dental
- Microelectronics
- Nuclear Power
- Offshore oil exploration
- Oil & gas
- Pharmaceuticals
- Power generation
- Pulp & paper
- Steel
- Water/wastewater

Key Products

- Analytical Instruments
- Analytical sample conditioning products & systems
- Chemical injection fittings & valves
- Fluoropolymer chemical delivery fittings, valves & pumps
- High purity gas delivery fittings, valves, regulators & digital flow controllers
- Industrial mass flow meters/ controllers
- Permanent no-weld tube fittings
- Precision industrial regulators & flow controllers
- Process control double block & bleeds
- Process control fittings, valves, regulators & manifold valves



Sealing & Shielding Key Markets

- Aerospace
- Chemical processing
- Consumer
- Fluid power
- General industrial
- Information technology
- Life sciences
- Microelectronics
- Military
- Oil & gas
- Power generation
- Renewable energy
- Telecommunications
- Transportation

Key Products

- Dynamic seals
- Elastomeric o-rings
- Electro-medical instrument design & assembly
- EMI shielding
- Extruded & precision-cut, fabricated elastomeric seals
- High temperature metal seals
- Homogeneous & inserted elastomeric shapes
- Medical device fabrication & assembly
- Metal & plastic retained composite seals
- Shielded optical windows
- Silicone tubing & extrusions
- Thermal management
- Vibration dampening

ENGINEERING YOUR SUCCESS.

Parker Worldwide

Europe, Middle East, Africa

AE – United Arab Emirates,
Dubai

Tel: +971 4 8127100
parker.me@parker.com

AT – Austria, Wiener Neustadt

Tel: +43 (0)2622 23501-0
parker.austria@parker.com

AT – Eastern Europe, Wiener
Neustadt

Tel: +43 (0)2622 23501 900
parker.easteurope@parker.com

AZ – Azerbaijan, Baku

Tel: +994 50 2233 458
parker.azerbaijan@parker.com

BE/LU – Belgium, Nivelles

Tel: +32 (0)67 280 900
parker.belgium@parker.com

BG – Bulgaria, Sofia

Tel: +359 2 980 1344
parker.bulgaria@parker.com

BY – Belarus, Minsk

Tel: +48 (0)22 573 24 00
parker.poland@parker.com

CH – Switzerland, Etoy

Tel: +41 (0)21 821 87 00
parker.switzerland@parker.com

CZ – Czech Republic, Klecany

Tel: +420 284 083 111
parker.czechrepublic@parker.com

DE – Germany, Kaarst

Tel: +49 (0)2131 4016 0
parker.germany@parker.com

DK – Denmark, Ballerup

Tel: +45 43 56 04 00
parker.denmark@parker.com

ES – Spain, Madrid

Tel: +34 902 330 001
parker.spain@parker.com

FI – Finland, Vantaa

Tel: +358 (0)20 753 2500
parker.finland@parker.com

FR – France, Contamine s/Arve

Tel: +33 (0)4 50 25 80 25
parker.france@parker.com

GR – Greece, Athens

Tel: +30 210 933 6450
parker.greece@parker.com

HU – Hungary, Budaörs

Tel: +36 23 885 470
parker.hungary@parker.com

IE – Ireland, Dublin

Tel: +353 (0)1 466 6370
parker.ireland@parker.com

IT – Italy, Corsico (MI)

Tel: +39 02 45 19 21
parker.italy@parker.com

KZ – Kazakhstan, Almaty

Tel: +7 7273 561 000
parker.easteurope@parker.com

NL – The Netherlands, Oldenzaal

Tel: +31 (0)541 585 000
parker.nl@parker.com

NO – Norway, Asker

Tel: +47 66 75 34 00
parker.norway@parker.com

PL – Poland, Warsaw

Tel: +48 (0)22 573 24 00
parker.poland@parker.com

PT – Portugal, Leca da Palmeira

Tel: +351 22 999 7360
parker.portugal@parker.com

RO – Romania, Bucharest

Tel: +40 21 252 1382
parker.romania@parker.com

RU – Russia, Moscow

Tel: +7 495 645-2156
parker.russia@parker.com

SE – Sweden, Spånga

Tel: +46 (0)8 59 79 50 00
parker.sweden@parker.com

SK – Slovakia, Banská Bystrica

Tel: +421 484 162 252
parker.slovakia@parker.com

SL – Slovenia, Novo Mesto

Tel: +386 7 337 6650
parker.slovenia@parker.com

TR – Turkey, Istanbul

Tel: +90 216 4997081
parker.turkey@parker.com

UA – Ukraine, Kiev

Tel: +48 (0)22 573 24 00
parker.poland@parker.com

UK – United Kingdom, Warwick

Tel: +44 (0)1926 317 878
parker.uk@parker.com

ZA – South Africa, Kempton Park

Tel: +27 (0)11 961 0700
parker.southafrica@parker.com

North America

CA – Canada, Milton, Ontario

Tel: +1 905 693 3000

US – USA, Cleveland

Tel: +1 216 896 3000

Asia Pacific

AU – Australia, Castle Hill

Tel: +61 (0)2-9634 7777

CN – China, Shanghai

Tel: +86 21 2899 5000

HK – Hong Kong

Tel: +852 2428 8008

IN – India, Mumbai

Tel: +91 22 6513 7081-85

JP – Japan, Tokyo

Tel: +81 (0)3 6408 3901

KR – South Korea, Seoul

Tel: +82 2 559 0400

MY – Malaysia, Shah Alam

Tel: +60 3 7849 0800

NZ – New Zealand, Mt Wellington

Tel: +64 9 574 1744

SG – Singapore

Tel: +65 6887 6300

TH – Thailand, Bangkok

Tel: +662 186 7000

TW – Taiwan, Taipei

Tel: +886 2 2298 8987

South America

AR – Argentina, Buenos Aires

Tel: +54 3327 44 4129

BR – Brazil, Sao Jose dos Campos

Tel: +55 800 727 5374

CL – Chile, Santiago

Tel: +56 2 623 1216

MX – Mexico, Toluca

Tel: +52 72 2275 4200

EMEA Product Information Centre

Free phone: 00 800 27 27 5374

(from AT, BE, CH, CZ, DE, DK, EE, ES, FI, FR, IE, IL, IS, IT, LU, MT, NL, NO, PL, PT, RU, SE, SK, UK, ZA)

US Product Information Centre

Toll-free number: 1-800-27 27 537

www.parker.com

Your local authorized Parker distributor

