

aerospace
climate control
electromechanical
filtration
fluid & gas handling
hydraulics
pneumatics
process control
sealing & shielding



P3Z Series Air preparation system

1 1/2" & 2" Body Ported, Modular SAE Blocks

Catalogue no. PDE2641TCUK - April 2021



ENGINEERING YOUR SUCCESS.

Filter / Dust Filter	4 - 5
Coalescing Filter / Adsorber Filter	6 - 7
Regulator / Pilot Regulator	8 - 9
Lubricator	10 - 11
Modular Manifold	12
Connection Flange Kits	12
Accessories	13

 **WARNING**

FAILURE OR IMPROPER SELECTION OR IMPROPER USE OF THE PRODUCTS AND/OR SYSTEMS DESCRIBED HEREIN OR RELATED ITEMS CAN CAUSE DEATH, PERSONAL INJURY AND PROPERTY DAMAGE.

This document and other information from Parker Hannifin Corporation, its subsidiaries and authorized distributors provide product and/or system options for further investigation by users having technical expertise. It is important that you analyze all aspects of your application and review the information concerning the product or system in the current product catalog. Due to the variety of operating conditions and applications for these products or systems, the user, through its own analysis and testing, is solely responsible for making the final selection of the products and systems and assuring that all performance, safety and warning requirements of the application are met. The products described herein, including without limitation, product features, specifications, designs, availability and pricing, are subject to change by Parker Hannifin Corporation and its subsidiaries at any time without notice.

SALE CONDITIONS

The items described in this document are available for sale by Parker Hannifin Corporation, its subsidiaries or its authorized distributors. Any sale contract entered into by Parker will be governed by the provisions stated in Parker's standard terms and conditions of sale (copy available upon request).

P3Z series modular air preparation system

The System

The all metal P3Z system allows units to be connected to most medium sized ring main installations by the use of either 1-1/2" or 2" flanges.

The P3Z Filters are specially designed to efficiently filter out rust, dirt, moisture and other impurities from compressed air lines. Operation is fully automatic with a minimum of pressure drop. Coalescing filters and adsorber filters for high purity air are also included in the P3Z series.

The P3Z Regulators are designed to provide quick response and accurate pressure regulation for the most demanding hi-flow industrial applications. The rolling diaphragm was designed for long trouble-free operation and will not rupture or tear under high cycle or other demanding applications.

The P3Z mist lubricators are designed to provide lubrication for many general purpose applications in a pneumatic system.

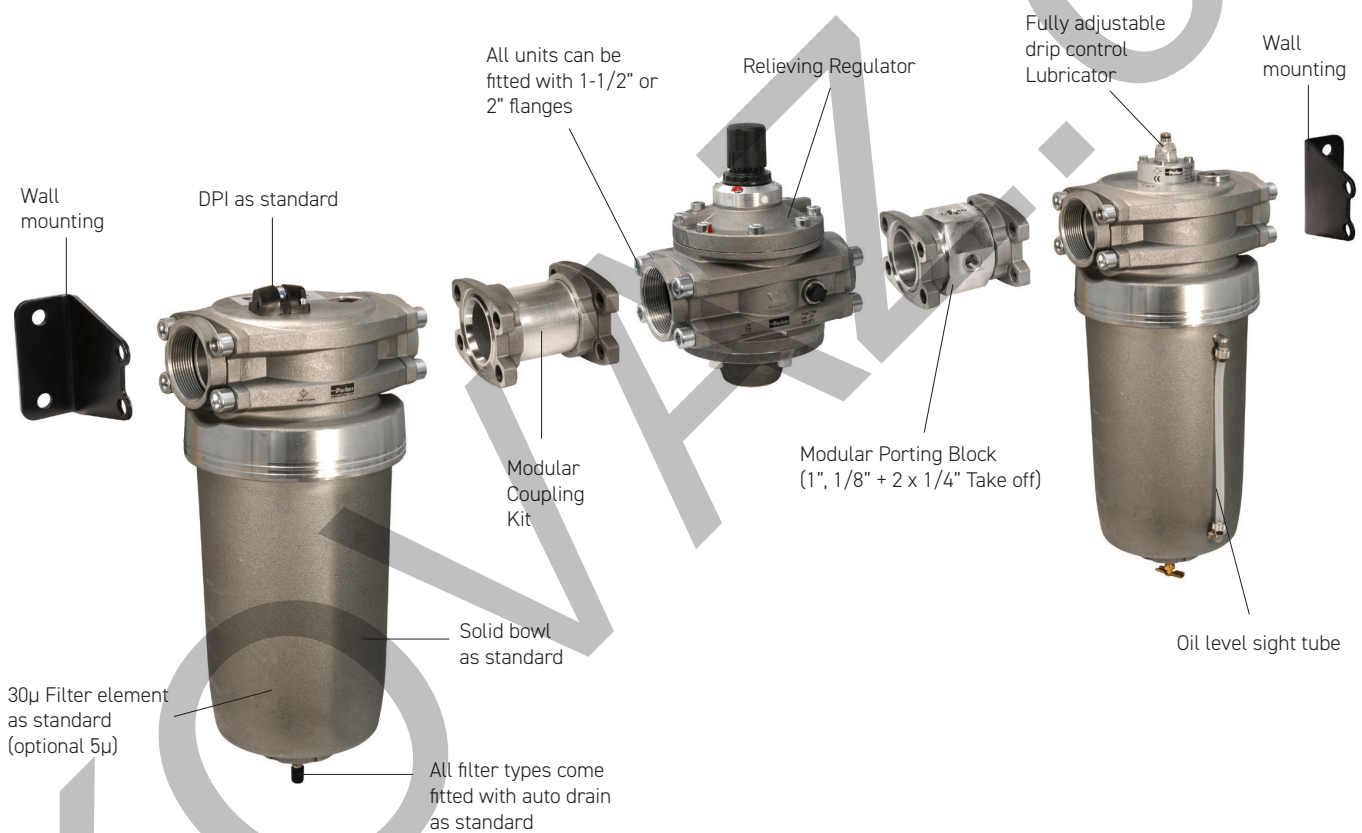

Filter-Regulator - Dust Filter-Adsorber

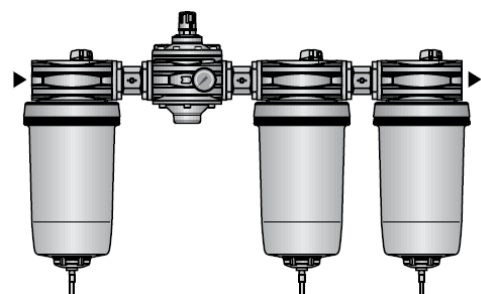

Particulate Filters



Symbols

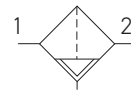

Auto drain

- Flanged 1-1/2" or 2" (BSPP & NPT)
- High efficiency particulate element as standard
- Excellent water removal efficiency
- Robust die-cast aluminium construction
- Standard DPI for monitoring (0.5 - 0.8 bar)

Note: To optimise the life of the dust 1µm element, it is advisable to install a P3ZFA pre-filter with a 5 micron element upstream of the coalescing filter.

Options:

P 3 Z F A						MA	N
SAE Mtg - No thread	0	None	0	30 Micron Element + DPI Standard	H	Auto Drain	MA
BSPP flange	1	1-1/2"	B	5 Micron Element + DPI Optional	F		
NPT flange	9	2"	C	1 Micron Element + DPI	M		

Port size	Description	Order Code	Flow dm ³ /s *	Max bar	Min temp °C	Max temp °C	Bowl capacity cm ³	Height mm	Width mm	Depth mm	Weight kg
-	30 micron, auto drain	P3ZFA00HMAN	>666	17.5	0	60	600	445	200	182	6.3
1-1/2"	30 micron, auto drain	P3ZFA1BHMAN	>666	17.5	0	60	600	445	200	182	6.3
2"	30 micron, auto drain	P3ZFA1CHMAN	>666	17.5	0	60	600	445	200	182	6.3
-	1 micron, auto drain	P3ZFA00MMAN	>666	17.5	0	60	600	445	200	182	6.3
1-1/2"	1 micron, auto drain	P3ZFA1BMMAN	>666	17.5	0	60	600	445	200	182	6.3
2"	1 micron, auto drain	P3ZFA1CMMAN	>666	17.5	0	60	600	445	200	182	6.3

* flow with 6,3 bar inlet pressure and 0,5 pressure drop.

Technical Information

Fluid:	Compressed air
Maximum inlet pressure*:	17.5 bar
Temperature range*:	0°C to +60°C
Particle removal:	30 & 5 micron
Typical flow with 30µm element 6,3 bar inlet pressure and 0.5 bar pressure drop:	666 dm ³ /s
Auto drain: bowl pressure to close drain Operating range manual override facility (depress pin)	0.8 bar 0.8 to 17.5 bar Ø 10mm brass connection
Bowl sump capacity:	600 cm ³

* Air supply must be dry enough to avoid ice formation at temperatures below +2°C

Material Specification

Body:	Aluminium
Element:	Sintered P.E.
Seals:	Nitrile NBR
Drains: Automatic:	PA / Brass connection
Differential pressure indicator materials:	
Body:	Acetal
Internal parts:	Acetal
Spring:	Stainless steel
Seals:	Nitrile NBR
Support plate	ABS
Screws	Steel / zinc plated

Dimensions (mm)

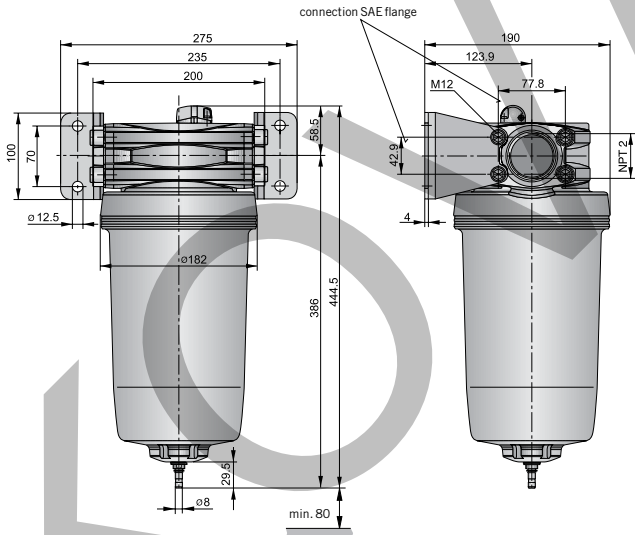

Flow characteristics

(2") 30 Micron Filter

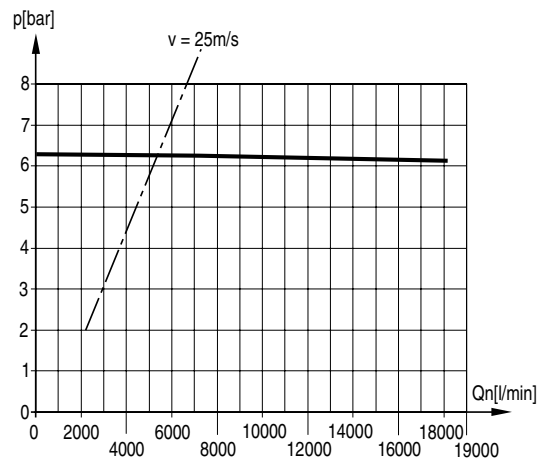

Service kits

Description	Order code
5 micron element kit	P3ZKA00ESE
30 micron element kit	P3ZKA00ESG
1 micron element kit	P3ZKA00ES9

Coalescing Filter / Adsorber Filter



- Extended high efficiency filter element provides greater filtration surface area.
- Flanged 1-1/2" or 2" (BSPP & NPT)
- Removes liquid aerosols and sub micron particles
- Oil free air for critical applications, such as air gauging, pneumatic instrumentation and control

Note: To optimise the life of the coalescing element, it is advisable to install a P3ZFA pre-filter with a 5µm filter upstream of the coalescing filter.

Note: To optimise the life of the adsorber element, it is advisable to install a P3ZFA coalescing 0.01µm filter upstream of the adsorber filter.

Options:

P 3 Z F A					M A		N
SAE Mtg - No thread	0	None	0	0.01 µm Coalescing element + DPI	D	Auto Drain	MA
BSPP flange	1	1-1/2"	B	Adsorber element + DPI	B		
NPT flange	9	2"	C				

Port size	Description	Order Code	Flow dm ³ /s *	Max bar	Min temp °C	Max temp °C	Bowl capacity cm ³	Height mm	Width mm	Depth mm	Weight kg
-	Coalescing filter 0.01 µm auto drain	P3ZFA00DMAN	>167	17.5	0	60	600	445	200	182	6.4
1-1/2"	Coalescing filter 0.01 µm auto drain	P3ZFA1BDMAN	>167	17.5	0	60	600	445	200	182	6.4
2"	Coalescing filter 0.01 µm auto drain	P3ZFA1CDMAN	>167	17.5	0	60	600	445	200	182	6.4
-	Adsorber filter	P3ZFA00BMAN	>167	17.5	0	60	600	445	200	182	6.4
1-1/2"	Adsorber filter	P3ZFA1BBMAN	>167	17.5	0	60	600	445	200	182	6.4
2"	Adsorber filter	P3ZFA1CBMAN	>167	17.5	0	60	600	445	200	182	6.4

* flow with 6,3 bar inlet pressure and 0,5 pressure drop.

Technical Information

Fluid:	Compressed air
Maximum inlet pressure*:	17.5 bar
Temperature range*:	0°C to +60°C
Media specifications:	
Coalescing efficiency	(0.3 to 0.6 micron particles): 99.97%
Max. oil carryover (PPM w/w):	0.008 mg/m ³
Typical flow element @	
6,3 bar inlet pressure	Dry element
and 0.2 bar pressure drop:	0.01µm @ dm ³ /s
Auto drain:	
bowl pressure to close drain	0.8 bar
Operating range	0.8 to 17.5 bar
manual override facility (depress pin)	∅ 10mm brass connection
Bowl sump capacity:	600 cm ³

* Air supply must be dry enough to avoid ice formation at temperatures below +2°C

Material Specification

Body:	Aluminium
Filter cover:	ABS
Coalescing element:	Borosilicate & Nano fibres
Top & bottom end cap:	Aluminium
Support cylinders:	Grade 430 stainless steel
Support media:	Polypropylene
Anti re-entrainment barrier:	Polyester
Ensapulate:	Epoxy resin / Hardener
Seals:	Nitrile NBR
Drains: Automatic:	PA / Brass connection

Differential pressure indicator materials:

Body:	Acetal
Internal parts:	Acetal
Spring:	Stainless steel
Seals:	Nitrile NBR
Support plate	ABS
Screws	Steel / zinc plated

Dimensions (mm)

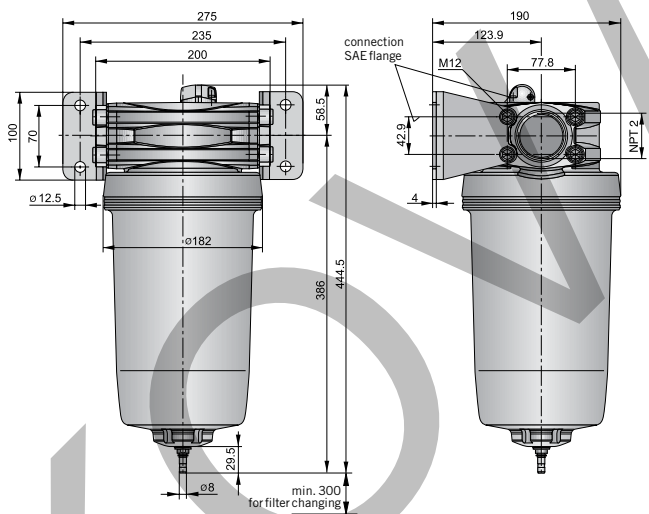

Flow characteristics

(2") 0.01µm Coalescing Filter Saturated

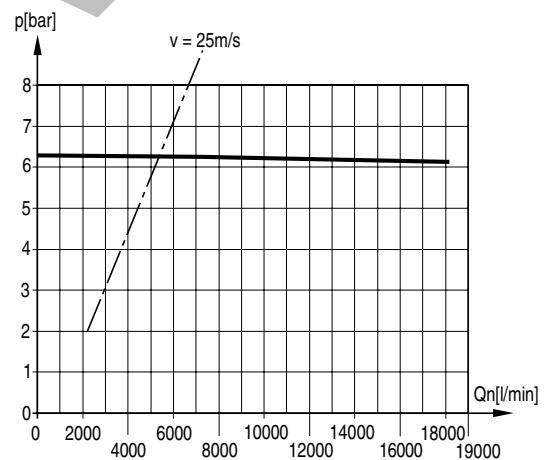

Service kits

Description	Order code
0.01 micron coalescing element kit	P3ZKA00ESC
Adsorber element kit	P3ZKA00ESA
Differential pressure indicator kit	P3ZKA00RQ

Regulator / Pilot Regulator

Symbols

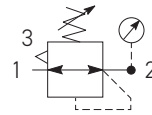

Self relieving regulator with gauge

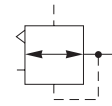

Air pilot

- Flanged 1-1/2" or 2" ports (BSPP & NPT)
- Robust die-cast aluminium construction
- Secondary pressure ranges 8 & 16 bar
- Rolling diaphragm for extended life
- Secondary aspiration plus rolling diaphragm provides quick response and accurate pressure regulation
- Air pilot regulator permanent bleed

Options:

P 3 Z R A			B	N		N
SAE Mtg - No thread	0	None	0	Relieving	B	0 - 8 bar No Gauge N
BSPP flange	1	1-1/2"	B			0 - 16 bar No Gauge H
NPT flange	9	2"	C			0 - 8 bar Gauge G
						0 - 16 bar Gauge J
P 3 Z R A			B P P N			
For Air Pilot Regulator option						

Port size	Description	Order Code	Flow dm ³ /s *	Max bar	Min temp °C	Max temp °C	Height mm	Width mm	Depth mm	Weight kg
-	8 bar relieving + gauge	P3ZRA00BNGN	>666	17.5	0	60	230	180	132	3.5
-	8 bar relieving	P3ZRA00BNNN	>666	17.5	0	60	230	180	132	3.5
1-1/2"	8 bar relieving + gauge	P3ZRA1BBNGN	>666	17.5	0	60	230	180	132	3.5
1-1/2"	8 bar relieving	P3ZRA1BBNNN	>666	17.5	0	60	230	180	132	3.5
2"	8 bar relieving + gauge	P3ZRA1CBNGN	>666	17.5	0	60	230	180	132	3.5
2"	8 bar relieving	P3ZRA1CBNNN	>666	17.5	0	60	230	180	132	3.5
-	16 bar relieving + gauge	P3ZRA00BNJN	>666	17.5	0	60	230	180	132	3.5
-	16 bar relieving	P3ZRA00BNHN	>666	17.5	0	60	230	180	132	3.5
1-1/2"	16 bar relieving + gauge	P3ZRA1BBNJN	>666	17.5	0	60	230	180	132	3.5
1-1/2"	16 bar relieving	P3ZRA1BBNHN	>666	17.5	0	60	230	180	132	3.5
2"	16 bar relieving + gauge	P3ZRA1CBNJN	>666	17.5	0	60	230	180	132	3.5
2"	16 bar relieving	P3ZRA1CBNHN	>666	17.5	0	60	230	180	132	3.5
-	Pilot Regulator	P3ZRA00BPPN	>666	17.5	0	60	182	180	132	3.4
1-1/2"	Pilot Regulator	P3ZRA1BBPPN	>666	17.5	0	60	182	180	132	3.4
2"	Pilot Regulator	P3ZRA1CBPPN	>666	17.5	0	60	182	180	132	3.4

* flow with 10 bar inlet 6,3 bar set pressure and 1 bar pressure drop.

Technical Information

Fluid:	Compressed air
Maximum inlet pressure*:	17.5 bar
Temperature range*:	0°C to +60°C
Typical flow with 10 bar inlet pressure, 8 bar set pressure and 1 bar pressure drop:	2" size >666 dm ³ /s
Gauge port (x 2):	1/4"

* Air supply must be dry enough to avoid ice formation at temperatures below +2°C

Dimensions (mm)

Pressure regulating valve, pilot operated with integrated pilot pressure regulating valve

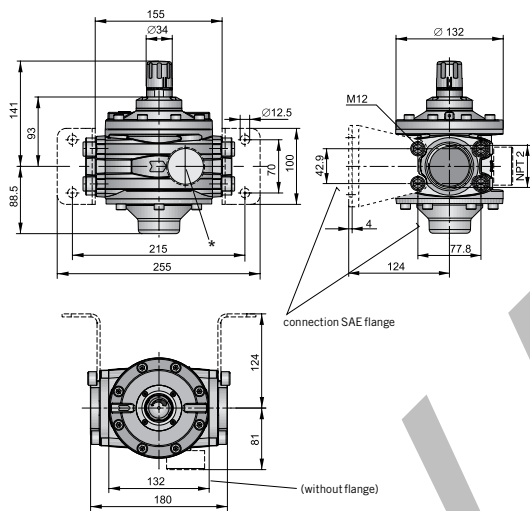

Pressure regulating valve, pilot operated

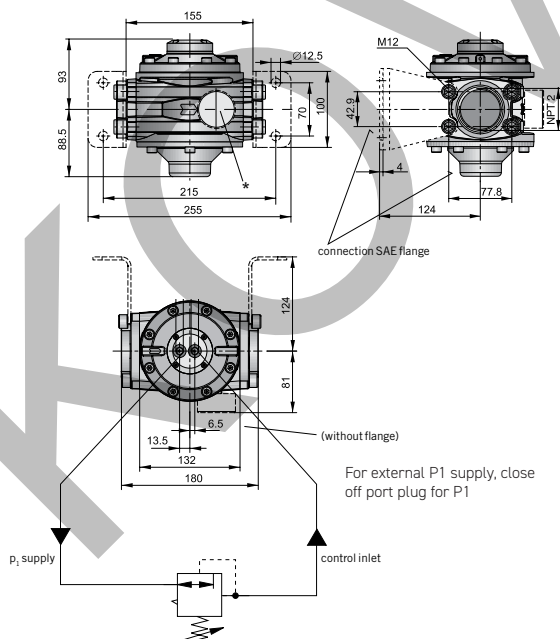

Material Specification

Body:	Aluminium
Bonnet:	Glass filled polyamide
Control Knob:	Glass filled polyamide
Valve:	Brass / NBR
Seals:	Nitrile NBR
Screws:	Steel / zinc plated

Flow characteristics

Pressure regulating valve characteristics - (2") Pilot operated

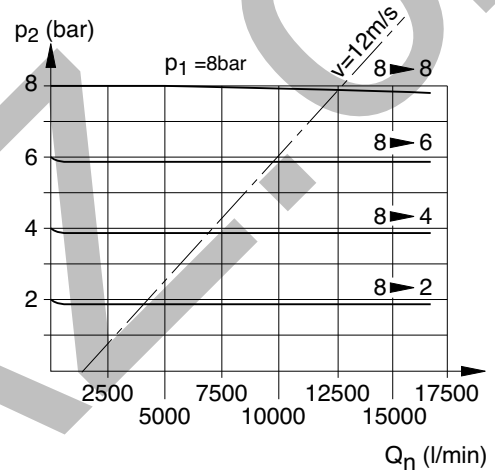

Service kits

Description	Order code
Diaphragm kit (relieving type)	P3ZKA00RR

Lubricator

Symbols

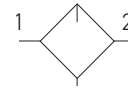

Lubricator with drain

- Flanged 1-1/2" or 2" ports (BSPP & NPT)
- Robust die-cast aluminium construction
- Proportional oil delivery over a wide range of air flows.
- Large oil reservoir

Options:

P 3 Z L A				L S M N	
SAE Mtg - No thread	0	None	0		
BSPP flange	1	1-1/2"	B		
NPT flange	9	2"	C		

Port size	Description	Order Code	Flow dm ³ /s *	Max bar	Min temp °C	Max temp °C	Bowl capacity cm ³	Height mm	Width mm	Depth mm	Weight kg
-	Lubricator	P3ZLA00LSMN	>666	17,5	0	60	600	460	200	182	6,5
1-1/2"	Lubricator	P3ZLA1BLSMN	>666	17,5	0	60	600	460	200	182	6,5
2"	Lubricator	P3ZLA1CLS MN	>666	17,5	0	60	600	460	200	182	6,5

* flow with 6,3 bar inlet pressure and 0,5 bar pressure drop.

Technical Information

Fluid:	Compressed air
Maximum inlet pressure*:	10 bar
Temperature range*:	5°C to +60°C

* Air supply must be dry enough to avoid ice formation at temperatures below +2° C
 Low flow start point (lubrication pick-up): at 6.3bar inlet pressure 0.5 dm³/s
 Typical flow with 6.3bar inlet pressure and 0.7 bar pressure drop: 184 dm³/s

Dimensions (mm)

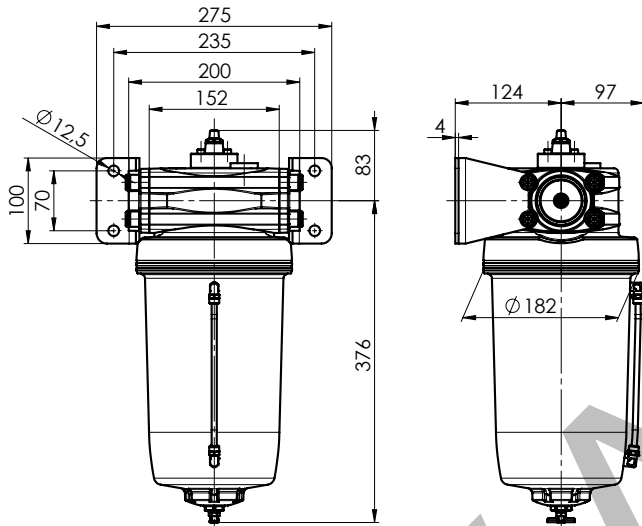

Material Specification

Body:	Aluminium
Sight dome:	Polyamide
Seals:	Nitrile NBR

Flow characteristics

(2") Lubricator

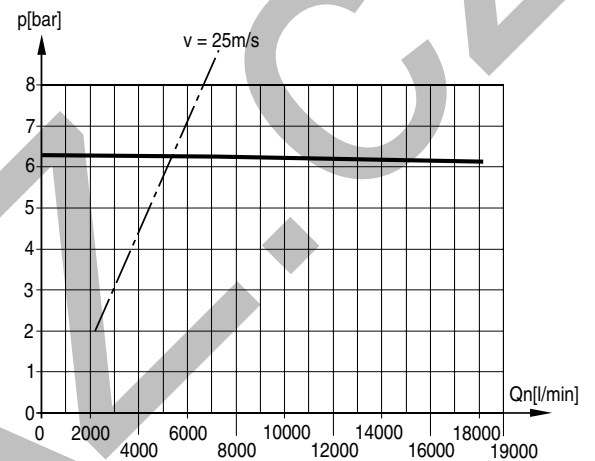

Service kits

Description	Order code
Drip control housing	P3ZKA00PG

Modular Manifold

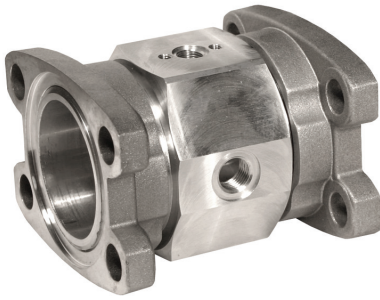

P3Z Series Manifolds, provide up to 4 extra outlet ports, they may be assembled at any position in a combination e.g. before the lubricator to provide oil free take off or at the end of a combination to provide extra outlet ports.

Thread type	Order code
BSPP	P3ZMA1V0N
NPT	P3ZMA9V0N

Inlet port	Top	Bottom	Front and Back
-	1/8"	1"	1/4"

Material specification:

Body:	Aluminium
Weight (kg):	1.1

Dimensions (mm)

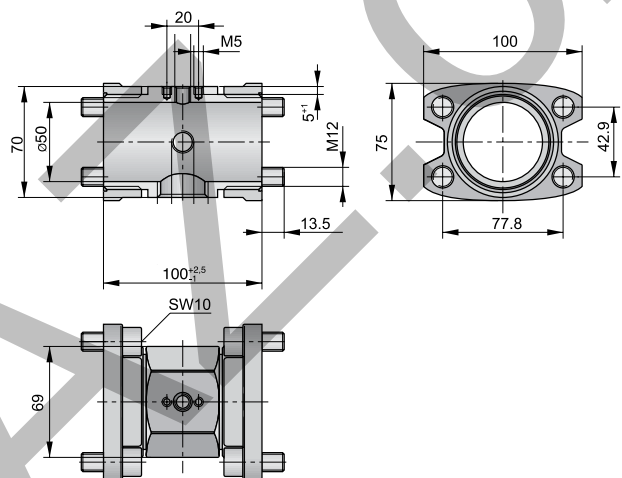

Connection Flange Kits

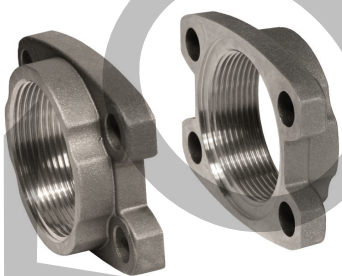

- To change port sizes connection flange kits are available, they are attached to any unit utilising the connecting kit.
- Allows assemblies to be removed from a hard piped system.





Options:

P 3 Z K A	<input type="checkbox"/>	<input type="checkbox"/>	C P
BSPP (G)	1	1 1/2"	B
NPT	9	2"	C

Material specification:

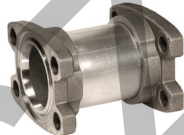
Body:	Aluminium
Weight (kg):	0.6

Accessories

Description	Connection	Weight	Order code (kg)		
Modular wall mounting kit			0.2	P3ZKA00MW	
Modular coupling kit			0.8	P3ZKA00CB	
Pressure gauge	0 to 10 bar 0 to 16 bar	1/4" 1/4"	0.06 0.06	KG8012-00 KG8013-00	
Lubricator Oil	VG32 - 1 litre		0.92	P3YKA00PPBB	
Modular coupling 'O' ring kit	Qty: 5			P3ZKA00CCY	

KOLVANZ.CZ

KOLVANZ.CZ

Parker Worldwide

Europe, Middle East, Africa

AE – United Arab Emirates, Dubai
Tel: +971 4 8127100
parker.me@parker.com

AT – Austria, St. Florian
Tel: +43 (0)7224 66201
parker.austria@parker.com

AZ – Azerbaijan, Baku
Tel: +994 50 2233 458
parker.azerbaijan@parker.com

BE/NL/LU – Benelux, Hendrik Ido Ambacht
Tel: +32 (0)0541 585 000
parker.nl@parker.com

BG – Bulgaria, Sofia
Tel: +359 2 980 1344
parker.bulgaria@parker.com

BY – Belarus, Minsk
Tel: +48 (0)22 573 24 00
parker.poland@parker.com

CH – Switzerland, Etoy
Tel: +41 (0)21 821 87 00
parker.switzerland@parker.com

CZ – Czech Republic, Klecany
Tel: +420 284 083 111
parker.czechrepublic@parker.com

DE – Germany, Kaarst
Tel: +49 (0)2131 4016 0
parker.germany@parker.com

DK – Denmark, Ballerup
Tel: +45 43 56 04 00
parker.denmark@parker.com

ES – Spain, Madrid
Tel: +34 902 330 001
parker.spain@parker.com

FI – Finland, Vantaa
Tel: +358 (0)20 753 2500
parker.finland@parker.com

FR – France, Contamine s/Arve
Tel: +33 (0)4 50 25 80 25
parker.france@parker.com

GR – Greece, Piraeus
Tel: +30 210 933 6450
parker.greece@parker.com

HU – Hungary, Budaors
Tel: +36 23 885 470
parker.hungary@parker.com

IE – Ireland, Dublin
Tel: +353 (0)1 466 6370
parker.ireland@parker.com

IL – Israel
Tel: +39 02 45 19 21
parker.israel@parker.com

IT – Italy, Corsico (MI)
Tel: +39 02 45 19 21
parker.italy@parker.com

KZ – Kazakhstan, Almaty
Tel: +7 7273 561 000
parker.easteurope@parker.com

NO – Norway, Asker
Tel: +47 66 75 34 00
parker.norway@parker.com

PL – Poland, Warsaw
Tel: +48 (0)22 573 24 00
parker.poland@parker.com

PT – Portugal, Leca da Palmeira
Tel: +351 22 999 7360
parker.portugal@parker.com

RO – Romania, Bucharest
Tel: +40 21 252 1382
parker.romania@parker.com

RU – Russia, Moscow
Tel: +7 495 645-2156
parker.russia@parker.com

SE – Sweden, Spånga
Tel: +46 (0)8 59 79 50 00
parker.sweden@parker.com

SK – Slovakia, Banská Bystrica
Tel: +421 484 162 252
parker.slovakia@parker.com

SL – Slovenia, Novo Mesto
Tel: +386 7 337 6650
parker.slovenia@parker.com

TR – Turkey, Istanbul
Tel: +90 216 4997081
parker.turkey@parker.com

UA – Ukraine, Kiev
Tel: +48 (0) 22 572 24 00
parker.poland@parker.com

UK – United Kingdom, Warwick
Tel: +44 (0)1926 317 878
parker.uk@parker.com

ZA – South Africa, Kempton Park
Tel: +27 (0)11 961 0700
parker.southafrica@parker.com

North America

CA – Canada, Milton, Ontario
Tel: +1 905 693 3000

US – USA, Cleveland
Tel: +1 216 896 3000

Asia Pacific

AU – Australia, Castle Hill
Tel: +61 (0)2-9634 7777

CN – China, Shanghai
Tel: +86 21 2899 5000

HK – Hong Kong
Tel: +852 2428 8008

IN – India, Mumbai
Tel: +91 22 6513 7081-85

JP – Japan, Tokyo
Tel: +81 (0)3 6408 3901

KR – South Korea, Seoul
Tel: +82 2 559 0400

MY – Malaysia, Shah Alam
Tel: +60 3 7849 0800

NZ – New Zealand, Mt Wellington
Tel: +64 9 574 1744

SG – Singapore
Tel: +65 6887 6300

TH – Thailand, Bangkok
Tel: +662 186 7000

TW – Taiwan, Taipei
Tel: +886 2 2298 8987

South America

AR – Argentina, Buenos Aires
Tel: +54 3327 44 4129

BR – Brazil, Sao Jose dos Campos
Tel: +55 800 727 5374

CL – Chile, Santiago
Tel: +56 2 623 1216

MX – Mexico, Toluca
Tel: +52 72 2275 4200

European Product Information Centre

Free phone: 00 800 27 27 5374

(from AT, BE, CH, CZ, DE, DK, EE, ES, FI, FR, IE, IL, IS, IT, LU, MT, NL, NO, PL, PT, RU, SE, SK, UK, ZA)

EMEA Product Information Centre

Free phone: 00 800 27 27 5374

(from AT, BE, CH, CZ, DE, DK, EE, ES, FI, FR, IE, IL, IS, IT, LU, MT, NL, NO, PL, PT, RU, SE, SK, UK, ZA)

US Product Information Centre

Toll-free number: 1-800-27 27 537

