



Pneumatic Cylinders

Ø10 to Ø125 mm P1S Series
According to ISO 6432 - 6431

PDE2535TCUK 10/2021



ENGINEERING YOUR SUCCESS.

OVERVIEW



Important

Before attempting any external or internal work on the cylinder or any connected components, make sure the cylinder is vented and disconnect the air supply in order to ensure isolation of the air supply.



Note

All technical data in this catalogue are typical data only.
Air quality is essential for maximum cylinder service life (see ISO 8573).



WARNING

FAILURE OR IMPROPER SELECTION OR IMPROPER USE OF THE PRODUCTS AND/OR SYSTEMS DESCRIBED HEREIN OR RELATED ITEMS CAN CAUSE DEATH, PERSONAL INJURY AND PROPERTY DAMAGE.

This document and other information from Parker Hannifin Corporation, its subsidiaries and authorized distributors provide product and/or system options for further investigation by users having technical expertise. It is important that you analyze all aspects of your application and review the information concerning the product or system in the current product catalog. Due to the variety of operating conditions and applications for these products or systems, the user, through its own analysis and testing, is solely responsible for making the final selection of the products and systems and assuring that all performance, safety and warning requirements of the application are met. The products described herein, including without limitation, product features, specifications, designs, availability and pricing, are subject to change by Parker Hannifin Corporation and its subsidiaries at any time without notice.

SALE CONDITIONS

The items described in this document are available for sale by Parker Hannifin Corporation, its subsidiaries or its authorized distributors. Any sale contract entered into by Parker will be governed by the provisions stated in Parker's standard terms and conditions of sale (copy available upon request).

P1S Series Stainless Steel Pneumatic Cylinders

Contents	Page
Stainless steel cylinders	4-5
P1S-S, ISO 6432, Ø10-Ø25	6-13
Cylinder forces	6
Main data	7
Cushioning diagram	8
Material specification	8
Dimensions	9
Order key	10
Stroke length	10
Mountings	11-13
P1S- ISO 6431, Ø32-Ø125	15-23
Cylinder forces	15
Main data	15
Cushioning diagram	15
Dimensions Ø32-Ø63	16
Material specification Ø32-Ø63	16
Dimensions Ø80-Ø125	17
Material specification Ø80-Ø125	17
Order key	18
Stroke length	18
Mountings	19-22
Seal kits	23
Sensors	24-29
Specifying air quality (purity)	30

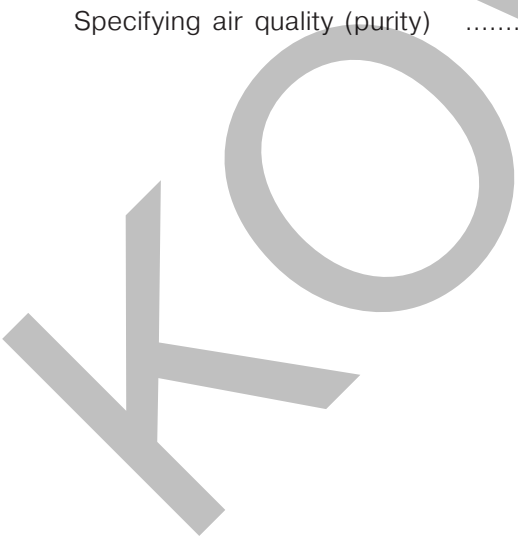

P1S Series Stainless Steel Pneumatic Cylinders

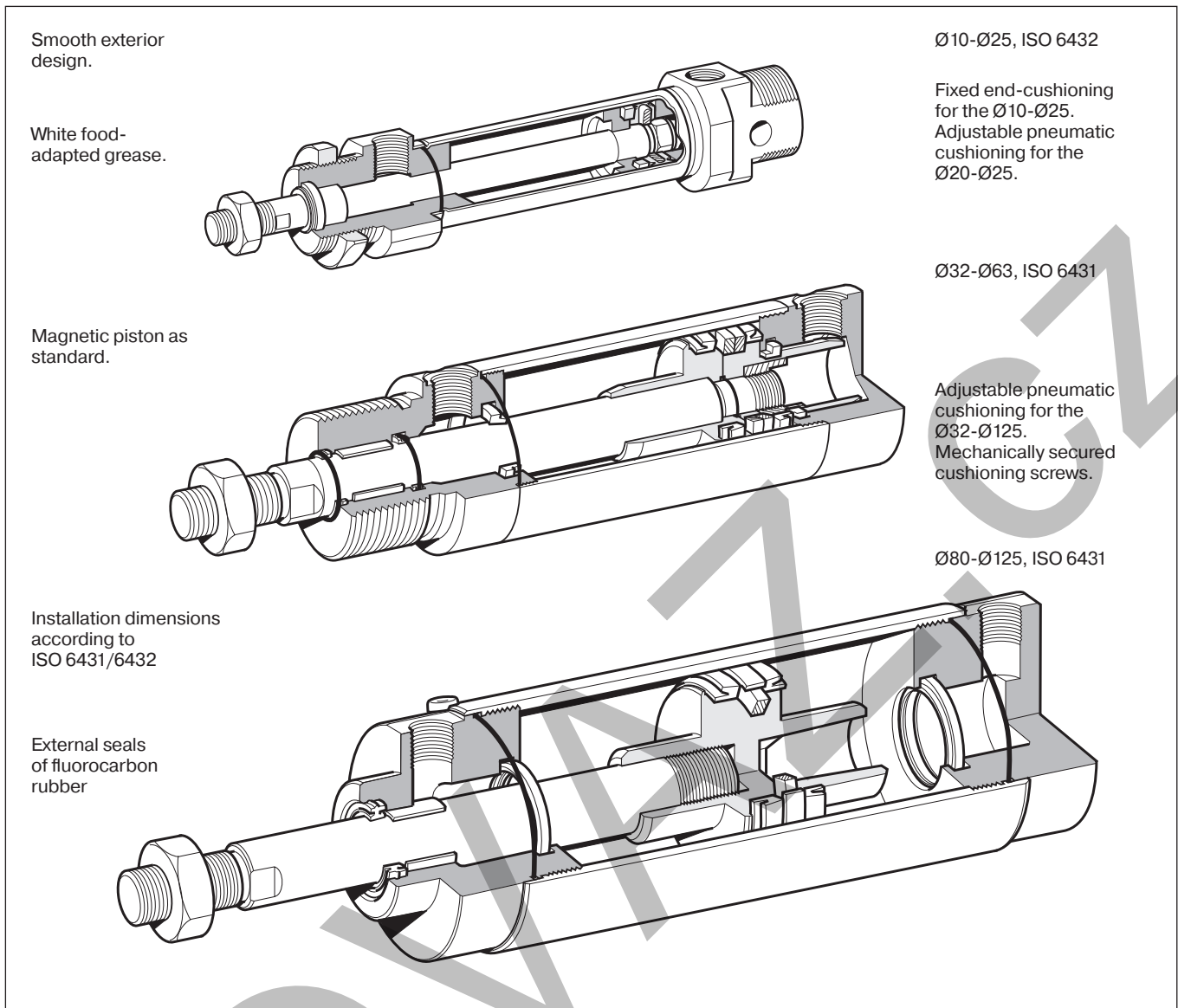

Stainless steel cylinders

Parker Pneumatic's range of stainless steel cylinders has been specially designed for use in difficult environments. Smooth design, external seals of fluorinated rubber and prelubrication with our food-industry-approved grease according to USDA-H1 make the cylinders particularly suitable for food industry use. All cylinders have magnetic pistons for proximity position sensing. Fixing dimensions to ISO 6431/6432 simplify installation and make the cylinders physically interchangeable throughout the world.

ISO 6432

The cylinders are available in two versions. One with fixed end-cushioning and is available in 10, 12, 16, 20 and 25 mm diameters. A single-acting version with spring return in the negative direction, is available in the same diameters.

One version has adjustable pneumatic end-cushioning and is available in 20 and 25 mm diameters.

ISO 6431

The ISO cylinders are double-acting round cylinders with several types of cylinder mountings as standard. The cylinders are available in 32 to 125 mm diameters, incorporating adjustable end-cushioning. As with the ISO 6432 it is designed to comply with hygiene requirements in accordance with the EU Machine Directive.

The cylinder can be dismantled to facilitate service and maintenance.

P1S Series Stainless Steel Pneumatic Cylinders

Stainless steel construction

The cylinders are made for use in particularly demanding environments. The piston rod, cylinder tube and end covers are all of stainless steel.

Effective end-cushioning

A version of ISO 6432 $\varnothing 10\text{-}\varnothing 25$ incorporates fixed end-cushioning, while the cylinders $\varnothing 20\text{-}\varnothing 125$ have pneumatic end-cushioning with adjusting screws for exact setting, permitting heavier loads and higher speeds for short cycle times.

Smooth external design

The end covers have no recesses or other grooves that could collect dirt or liquid. Cleaning is easy and effective.

Dry operation

Particular attention has been paid to the design of the cylinders' scraper rings, piston rod bearings and piston rod seals. Self-lubricating materials permit regular washing/degreasing of the piston rod. This is important in applications where hygiene and cleaning must be of high standard.

Proximity position sensing

All cylinders in normal temperature design are fitted with a magnet for proximity position sensing. Electronic type sensors and reed switches are available. They are supplied with either flying lead or cable plug connector.

Complete range of mountings

A complete range of stainless steel mounting accessories with ISO dimensions is available.

Variants

In addition to the basic design, several standard variants of these stainless steel cylinders are available to fulfill more demanding requirements in terms of performance and environmental conditions:

- Cylinders with special stroke lengths
- Cylinders with extended piston rods
- Single-acting cylinders ($\varnothing 10\text{-}\varnothing 25$)
- High-temperature versions for operation in temperature range:
 - $\varnothing 10$ to $\varnothing 16$ mm from $-10\text{ }^{\circ}\text{C}$ to $+120\text{ }^{\circ}\text{C}$ (not magnetic piston)
 - $\varnothing 20$ to $\varnothing 125$ mm from $-10\text{ }^{\circ}\text{C}$ to $+150\text{ }^{\circ}\text{C}$ (not magnetic piston)



Double acting $\varnothing 10\text{-}\varnothing 25$, fixed end-cushioning



Double acting $\varnothing 20\text{-}\varnothing 25$, adjustable end-cushioning



Double acting $\varnothing 10\text{-}\varnothing 25$, through piston rod



Single acting $\varnothing 10\text{-}\varnothing 25$



Double acting $\varnothing 32\text{-}\varnothing 63$



Double acting $\varnothing 80\text{-}\varnothing 125$

P1S Series Stainless Steel Pneumatic Cylinders

Cylinder forces, double acting variants

Cyl. bore/ pist. rod mm	Stroke	Piston area cm ²	Max theoretical force in N (bar)									
			1.0	2.0	3.0	4.0	5.0	6.0	7.0	8.0	9.0	10.0
10/4	+	0.8	8	16	24	31	39	47	55	63	71	79
	-	0.7	7	13	20	26	33	40	46	53	59	66
12/6	+	1.1	11	23	34	45	57	68	79	90	102	113
	-	0.8	8	17	25	34	42	51	59	68	76	85
16/6	+	2.0	20	40	60	80	100	120	141	161	181	201
	-	1.7	17	35	52	69	86	104	121	138	156	173
20/8	+	3.1	31	63	94	126	157	188	220	251	283	314
	-	2.6	26	53	79	106	132	158	185	211	238	264
25/10	+	4.9	49	98	147	196	245	295	344	393	442	491
	-	4.1	41	82	124	165	206	247	289	330	371	412

+ = Outward stroke
- = Return stroke

Note!
Select a theoretical force 50-100% larger than the force required

Cylinder forces single acting variants

Indicated cylinder forces are theoretical and should be reduced according to the working conditions.

Order code	Theoretical piston force at 6 bar				Order code	Theoretical piston force at 6 bar			
	Nmax	Nmin	Spring retraction Nmax	Nmin		Nmax	Nmin	Spring extension Nmax	Nmin
Single acting. spring return					Single acting. spring-extend				
P1S-S010SS-0010	38	36	10	8.5	P1S-S016TS-0010	85	84	22.3	20.2
P1S-S010SS-0015	38	36	10	7.8	P1S-S016TS-0015	86	84	22.3	19
P1S-S010SS-0025	39	36	10	6.6	P1S-S016TS-0025	88	84	22.3	17
P1S-S010SS-0040	38	34	13	9	P1S-S016TS-0040	90	84	22.3	14
P1S-S010SS-0050	39	34	13	8	P1S-S016TS-0050	91	84	22.3	12
P1S-S010SS-0080	39	34	12	7					
P1S-S012SS-0010	53	51	16	14.4	P1S-S020TS-0010	132	130	30	28
P1S-S012SS-0015	53	51	16	13.6	P1S-S020TS-0015	133	130	30	27
P1S-S012SS-0025	55	51	16	12	P1S-S020TS-0025	135	130	30	25
P1S-S012SS-0040	52	48	19	13.4	P1S-S020TS-0040	138	130	30	22
P1S-S012SS-0050	53	48	19	12	P1S-S020TS-0050	140	130	30	20
P1S-S012SS-0080	55	48	21.4	12	P1S-S020TS-0080	139	108	31	17
					P1S-S025TS-0010	205	203	38.5	36
P1S-S016SS-0010	102	99	22.3	20.2	P1S-S025TS-0015	207	203	38.5	34.7
P1S-S016SS-0015	103	99	22.3	19	P1S-S025TS-0025	210	203	38.5	32
P1S-S016SS-0025	105	99	22.3	17	P1S-S025TS-0040	214	203	38.5	28.5
P1S-S016SS-0040	106	95	22.3	14	P1S-S025TS-0050	217	203	38.5	26
P1S-S016SS-0050	108	95	22.3	12	P1S-S025TS-0080	223	206	36	21
P1S-S016SS-0080	107	95	22.5	12					
P1S-S020SS-0010	163	161	30	28					
P1S-S020SS-0015	164	161	30	27					
P1S-S020SS-0025	167	161	30	25					
P1S-S020SS-0040	166	159	30	22					
P1S-S020SS-0050	168	159	30	20					
P1S-S020SS-0080	170	161	29.4	18					
P1S-S025SS-0010	256	253	44.3	41.4					
P1S-S025SS-0015	258	253	44.3	40					
P1S-S025SS-0025	262	253	44.3	37					
P1S-S025SS-0040	261	250	44.3	32					
P1S-S025SS-0050	264	250	44.3	30					
P1S-S025SS-0080	264	251	44.4	30					

Main data

Cylinder designation	Cylinder bore		Piston rod bore		thread	Total mass		Air consumption	Conn. thread
	mm	cm ²	mm	cm ²		at 0 mm stroke	addition per 10 mm stroke		
	mm	cm ²	mm	cm ²		kg	kg	litres	
Double acting. cushioned stroke									
P1S-S010D	10	0.78	4	0.13	M4	0.04	0.003	0.0100 ¹⁾	M5
P1S-S012D	12	1.13	6	0.28	M6	0.07	0.004	0.0139 ¹⁾	M5
P1S-S016D	16	2.01	6	0.28	M6	0.09	0.005	0.0262 ¹⁾	M5
P1S-S020D	20	3.14	8	0.50	M8	0.18	0.007	0.0405 ¹⁾	G1/8
P1S-S025D	25	4.91	10	0.78	M10x1.25	0.25	0.011	0.0633 ¹⁾	G1/8
Double acting. adjustable cushioning									
P1S-S020M	20	3.14	8	0.50	M8	0.18	0.007	0.0405 ¹⁾	G1/8
P1S-S025M	25	4.91	10	0.78	M10x1.25	0.25	0.011	0.0633 ¹⁾	G1/8
Single acting. spring return									
P1S-S010SS	10	0.78	4	0.13	M4	0.04	0.003	0.0055 ¹⁾	M5
P1S-S012SS	12	1.13	6	0.28	M6	0.08	0.004	0.0079 ¹⁾	M5
P1S-S016SS	16	2.01	6	0.28	M6	0.10	0.005	0.0141 ¹⁾	M5
P1S-S020SS	20	3.14	8	0.50	M8	0.18	0.007	0.0220 ¹⁾	G1/8
P1S-S025SS	25	4.91	10	0.78	M10x1.25	0.26	0.011	0.0344 ¹⁾	G1/8
Single acting. spring-extended									
P1S-S016TS	16	2.01	6	0.28	M6	0.10	0.005	0.0141 ¹⁾	M5
P1S-S020TS	20	3.14	8	0.50	M8	0.18	0.007	0.0220 ¹⁾	G1/8
P1S-S025TS	25	4.91	10	0.78	M10x1.25	0.26	0.011	0.0344 ¹⁾	G1/8

1) Free air consumption per 10 mm stroke length for a double stroke at 6 bar

Working medium, air quality

Working medium Dry, filtered compressed air to ISO 8573-1 class 3.4.3.

Recommended air quality for cylinders

For best possible service life and trouble-free operation, ISO 8573-1 quality class 3.4.3 should be used. This means 5 µm filter (standard filter) dew point +3 °C for indoor operation (a lower dew point should be selected for outdoor operation) and oil concentration 1.0 mg oil/m³, which is what a standard compressor with a standard filter gives.

Additional data

Working pressure	max 10 bar
Working temperature	max +80 °C min -20 °C
High-temperature version	Ø10 to Ø16 max +120 °C Ø20 to Ø25 max +150 °C

Prelubricated, further lubrication is not normally necessary. If additional lubrication is introduced it must be continued.

ISO 8573-1 quality classes

Quality class	Pollution		Water	Oil
	particle size (µm)	max concentration (mg/m ³)	max press dew point (°C)	max concentration (mg/m ³)
1	0.1	0.1	-70	0.01
2	1	1	-40	0.1
3	5	5	-20	1.0
4	15	8	+3	5.0
5	40	10	+7	25.
6	-	-	+10	-

Material specification

Piston rod	Stainless steel, X8 CrNiS 18-10 (AISI 321)
Piston rod bearing	Multilayer PTFE/steel
End covers	Stainless steel, X5 CrNi 18-10 (AISI 304)
O-ring, internal	Nitrile rubber, NBR
Cylinder barrel	Stainless steel, X5 CrNi 18-10 (AISI 304)
Magnet holder	Thermoplastic elastomer
Magnet	Plastic-coated magnetic material
Return spring	Surface-treated steel
Cushioning screw	Stainless steel, X10 CrNiS 18-9 (AISI 303)

Variants Mini ISO:

Standard-temperature version, type S:

Piston rod seal	Nitrile rubber, NBR
Piston complete	Nitrile rubber, NBR/steel

High-temperature version, type F:

Piston rod seal	Fluorocarbon rubber, FPM
Piston complete	HNBR/steel

Cylinders with outer sealings in fluorocarbon, type V:

Piston rod seal/ Scraper ring	Fluorocarbon rubber, FPM
Piston complete	Nitrile rubber, NBR/steel

Spare part = new cylinder

Cushioning diagram

Use the diagram below to determine the necessary size of cylinder to provide the requisite cushioning performance. The maximum cushioning performance, as indicated in the diagram, is based on the following assumptions:

- Low load, i.e. low pressure drop across the piston
- Steady-state piston speed
- Correctly adjusted cushioning screw

The load is the sum of the internal and external friction, together with any gravity forces. At high relative loading it is recommended that, for a given speed, the load should be reduced by a factor of 2.5, or that, for a given mass, the speed should be reduced by a factor of 1.5. These factors apply in relation to the maximum performance as shown in the diagram.

Fixed end-cushioning
Speed [m/s]

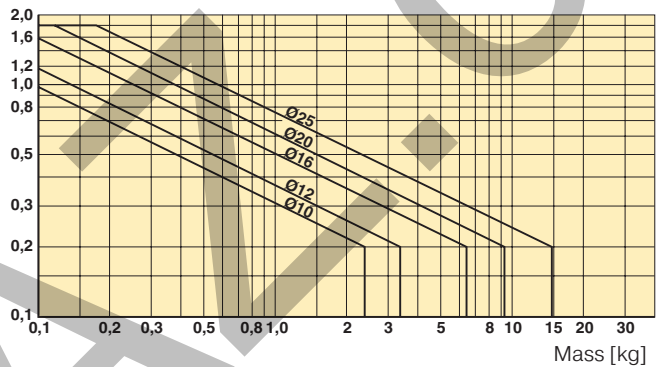

Adjustable pneumatic end-cushioning
Speed [m/s]

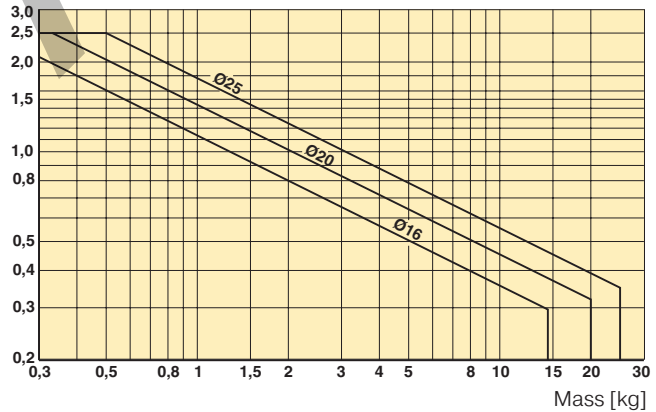

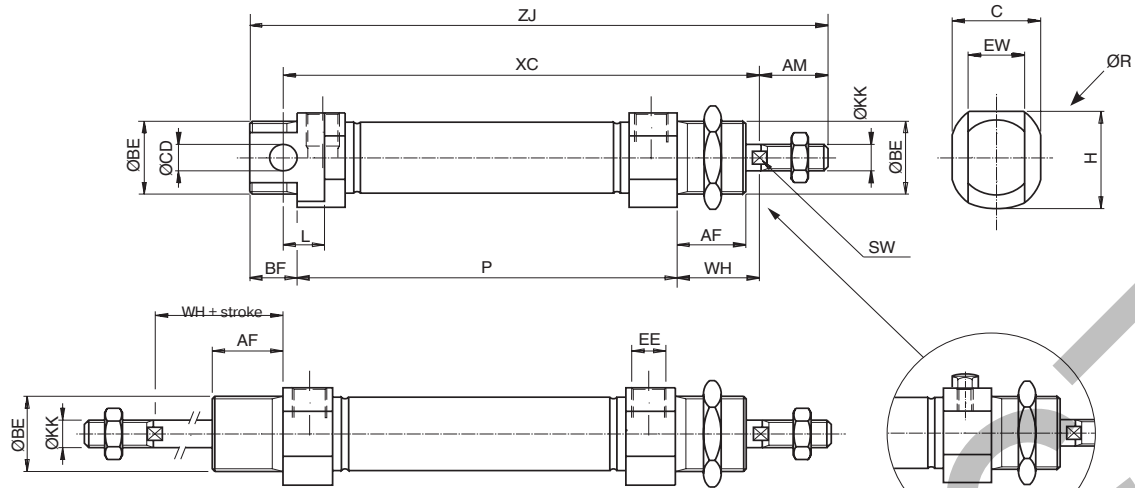

Dimensions Ø10 - Ø25

Cylinder bore mm	EE	Ø BE mm	Ø CD H9 mm	BF mm	L mm	AF mm	WH ±1,2 mm	AM 0/-2 mm	Ø KK mm	SW mm	C mm	EW mm	H mm	Ø R mm
10 ¹⁾	M5	M12x1,25	4	10	6	12	16	12	M4	-	13,0	8	13,5	16,0
10 ²⁾	M5	M12x1,25	4	10	6	12	16	12	M4	-	13,0	8	14,0	16,0
12	M5	M16x1,50	6	13	9	18	22	16	M6	5	17,8	12	17,8	20,0
16	M5	M16x1,50	6	13	9	18	22	16	M6	5	17,8	12	17,8	20,0
20	G1/8	M22x1,50	8	14	12	20	24	20	M8	7	23,8	16	23,8	27,0
25	G1/8	M22x1,50	8	14	12	22	28	22	M10x1,25	9	26,8*	16	26,8*	31*

¹⁾ SS / TS single acting ²⁾ DS / MS double acting * For K_, SF, F_ version dimensions are 27,5 | 27,5 | Ø34

Double acting cylinders

Cylinder bore mm	ZJ mm	XC mm	P mm
10	84 + stroke	64 + stroke	46 + stroke
12	99 + stroke	75 + stroke	48 + stroke
16 ²⁾	104 + stroke	82 + stroke	53 + stroke
20 ²⁾	125 + stroke	95 + stroke	67 + stroke
25 ²⁾	132 + stroke	104 + stroke	68 + stroke

Single acting cylinders, spring return type S

Stroke mm	10	15	25	40	50	80	10	15	25	40	50	80	10	15	25	40	50	80
Cyl. bore mm	XC	XC	XC	XC	XC	XC	ZJ	ZJ	ZJ	ZJ	ZJ	ZJ	P	P	P	P	p	P
10	74	79	89	126	136	174	94	99	109	146	156	194	56	61	71	108	118	156
12	85	90	100	132	142	185	109	114	124	156	166	209	58	63	73	105	115	158
16	92	97	107	122	132	184	114	119	129	144	154	206	63	68	78	93	103	155
20	105	110	120	135	145	191	135	140	150	165	175	221	77	82	92	107	117	163
25	114	119	129	144	154	201	142	147	157	172	182	229	78	83	93	108	118	165

Length tolerances ±1mm
Stroke length tolerances +1.5/0 mm

Cylinders are supplied complete with mounting and adjusting nuts. Cylinders with through piston rod are supplied complete with two adjusting nuts and one mounting nut.







Single acting cylinders, spring extend type T

Stroke mm	10	15	25	40	50	80	10	15	25	40	50	80	10	15	25	40	50	80
Cyl. bore mm	XC ³⁾	XC ³⁾	XC ³⁾	XC ³⁾	XC ³⁾	XC ³⁾	ZJ ³⁾	ZJ ³⁾	ZJ ³⁾	ZJ ³⁾	ZJ ³⁾	ZJ ³⁾	P	P	P	P	p	P
16	107	112	122	137	147	-	129	134	144	159	169	-	78	83	93	108	118	-
20	120	125	135	150	160	195	150	155	165	180	190	225	92	97	107	122	132	167
25	129	134	144	159	169	205	157	162	172	187	197	233	93	98	108	123	133	169

³⁾ With piston rod retracted as shown in the dimension drawing Length tolerances ±1mm Stroke length tolerances +1.5/0 mm

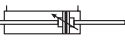
Order key

P1S - S 016 M S - 0025

Cylinder bore mm	Cylinder type / function	Stroke in mm	Sealing material
010	M  Double-acting, adjustable cushioning. Ø 20-25 mm. Not for sealing material type F.	E.g. 0025 = 25 mm For standard stroke length and max length, see table below	S Standard, -20 °C to +80 °C. Magnetic piston
012	D  Double-acting, non-adjustable cushioning, Ø10 - 25 mm		F  High temperature, Ø10 to Ø16 -10 to +120°C Ø20 to Ø25 -10 to +150°C Non-magnetic piston
016	F  Double-acting, adjustable cushioning, thru-rod, Ø 20 - 25 mm. Not for sealing material type F.		V External seals of fluorinated rubber. -20 °C to +80 °C. Magnetic piston
020	K  Double-acting, non-adjustable cushioning, thru-rod, Ø10 - 25 mm		
025	S  Single-acting, non-adjustable cushioning, spring return for retract stroke, Ø10 - 25 mm. Not for sealing material type F & V.		
	T  Single-acting, non-adjustable cushioning, spring return for advance stroke, Ø16 - 25 mm. Not for sealing material type F & V.		

Stroke length

Cylinder designation	Cylinder bore	● Standard stroke length in mm										■ Non standard stroke length					
		10	15	20	25*	30	40	50*	80*	100*	125*	160*	200*	250*	320*	400*	500*
Double acting with fixed end-cushioning:																	
P1S-S010D	10	●	●	●	●	●	●	●	●	●	●	●	●	●	●	●	●
P1S-S012D	12	●	●	●	●	●	●	●	●	●	●	●	●	●	●	●	●
P1S-S016D	16	●	●	●	●	●	●	●	●	●	●	●	●	●	●	●	●
P1S-S020D	20	●	●	●	●	●	●	●	●	●	●	●	●	●	●	●	●
**																	
P1S-S025D	25	●	●	●	●	●	●	●	●	●	●	●	●	●	●	●	●
**																	
Double acting with adjustable end-cushioning:																	
P1S-S020M	20	●	●	●	●	●	●	●	●	●	●	●	●	●	●	●	●
● **																	
P1S-S025M	25	●	●	●	●	●	●	●	●	●	●	●	●	●	●	●	●
● **																	
Single acting, spring return:																	
P1S-S010SS	10	●	●	●	●	●	●	●	●	●	●	●	●	●	●	●	●
P1S-S012SS	12	●	●	●	●	●	●	●	●	●	●	●	●	●	●	●	●
P1S-S016SS	16	●	●	●	●	●	●	●	●	●	●	●	●	●	●	●	●
P1S-S020SS	20	●	●	●	●	●	●	●	●	●	●	●	●	●	●	●	●
P1S-S025SS	25	●	●	●	●	●	●	●	●	●	●	●	●	●	●	●	●
Single acting, spring-extended:																	
P1S-S016TS	16	●	●	●	●	●	●	●	●	●	●	●	●	●	●	●	●
P1S-S020TS	20	●	●	●	●	●	●	●	●	●	●	●	●	●	●	●	●
P1S-S025TS	25	●	●	●	●	●	●	●	●	●	●	●	●	●	●	●	●

* Standard stroke lengths in mm according to ISO 4393

** Max stroke 1000 mm

Cylinder mountings

Type	Description	Cyl. bore Ø mm	Weight kg	Order code
Stainless flange MF8	Intended for fixed attachment of the cylinder. The flange is designed for mounting on the front or rear end-covers. Material: Stainless steel, X10 CrNiS 18-9 (AISI 303)	10	0.012	P1S-4CMB P1S-4DMB P1S-4HMB
		12-16	0.025	
		20-25	0.045	



Cylinder Ø mm	A mm	B mm	C mm	D mm	E mm	F mm
10	4.5	30	40	22	3	13
12-16	5.5	40	52	30	4	18
20	6.6	50	66	40	5	19
25	6.6	50	66	40	5	23

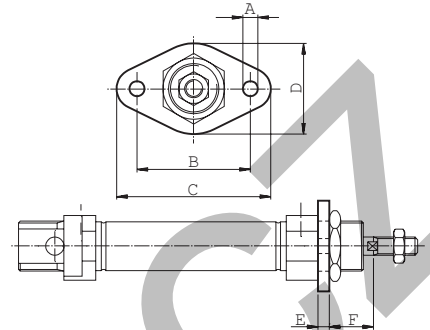

Stainless foot MS3	Intended for fixed attachment of the cylinder. The bracket is designed for mounting on the front or rear end-covers. Material: Stainless steel, X10 CrNiS 18-9 (AISI 303)	10	0.020	P1S-4CMF P1S-4DMF P1S-4HMF
		12-16	0.040	
		20-25	0.080	



Cylinder Ø mm	A mm	B mm	C mm	D mm	E mm	F mm	G mm	H mm	I mm
10	4.5	16	25	35	3	24	26	16	11
12-16	5.5	20	32	42	4	32	32.5	20	14
20	6.6	25	40	54	5	36	45	25	17
25	6.6	25	40	54	5	40	45	25	17

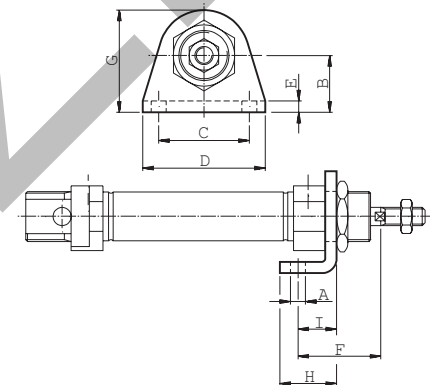

Stainless Cover trunnion	Intended for articulated mounting of the cylinder. The flange is designed for mounting on the front or rear end-covers. Material: Stainless steel, X10 CrNiS 18-9 (AISI 303)	10	0.014	P1A-4CMJ P1A-4DMJ P1A-4HMJ
		12-16	0.033	
		20-25	0.037	



Cylinder Ø mm	A mm	B h14 mm	C mm	D mm	E e9 mm	F mm	G mm	H mm
10	12.5	26	38	20	8	4	6	10
12-16	16.5	38	58	25	10	6	8	14
20	22.5	46	66	30	10	6	8	16
25	22.5	46	66	30	10	6	8	20

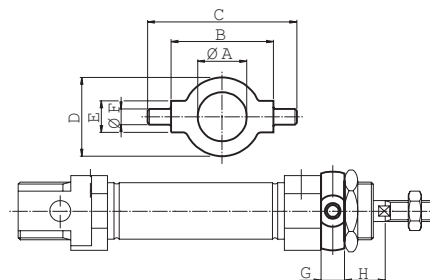

Cylinder mountings

Type	Description	Cyl. bore Ø mm	Weight kg	Order code
Stainless Neck nut MR3	Intended for fixed mounting of the cylinder. Cylinders are supplied complete with one mounting nut. Material: Stainless steel, X5 CrNi 18-10 (AISI 304) Supplied in quantity packs of 10 off.	10	0.009	P14-4LRPS P14-4MRPS P14-4HRMS
		12-16	0.018	
		20-25	0.042	



Cylinder Ø mm	A mm	B mm	C mm
10	19	6	M12x1,25
12-16	24	8	M16x1,50
20-25	27	5	M22x1,50

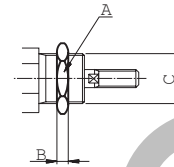

Stainless Clevis bracket AB3	Intended for articulated mounting of the cylinder. Supplied with shaft for mounting on the rear end cover. Material: Bracket: stainless steel, X5 CrNi 18-10 (AISI 304) Pin: tempered stainless steel, X 20 Cr 13 (AISI 420) Locking rings: stainless steel, X5 CrNi 18-10 (AISI 304)	10	0.020	P1S-4CMT P1S-4DMT P1S-4HMT
		12-16	0.040	
		20-25	0.080	



Cylinder Ø mm	A mm	B mm	C mm	D mm	E mm	F mm	G mm	H mm	I °	J °
10	4,5	13	8.1	24	12,5	20	65,3	5	160	17
12	5.5	18	12.1	27	15	25	73	7	170	15
16	5.5	18	12.1	27	15	25	80	7	170	15
20	6.6	24	16.1	30	20	32	91	10	165	10
25	6.6	24	16.1	30	20	32	100	10	165	10

S = stroke

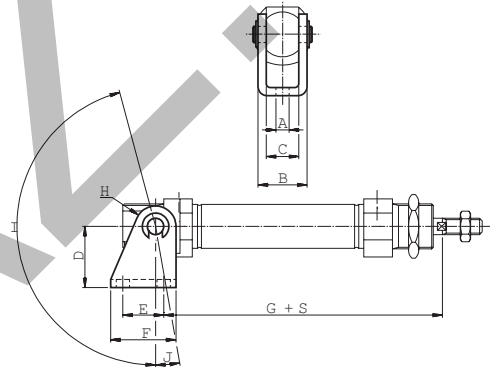

Stainless Clevis AP2	According to ISO 8140 Intended for articulated mounting of the cylinder. This mounting is adjustable in the axial direction. Supplied complete with pin. Material: Stainless steel, X5 CrNi 18-10 (AISI 304)	10	0.007	P1S-4CRD P1S-4DRD P1S-4HRD P1S-4JRD
		12-16	0.022	
		20	0.045	
		25	0.095	



Cylinder Ø mm	A mm	B mm	C mm	D mm	E mm	F mm	G mm	H mm	I mm	J mm
10	4	M4	2.2	8	8	5	16	4	22	2
12-16	6	M6	3.2	12	12	7	24	6	31	3
20	8	M8	4	16	16	10	32	8	40.5	3.5
25	10	M10x1.25	5	20	20	12	40	10	49	3

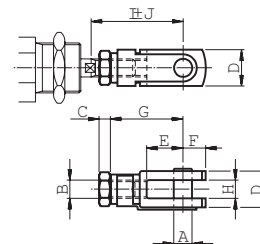

Cylinder mountings

Type	Description	Cyl. bore Ø mm	Weight kg	Order code
Stainless Swivel rod eye AP6	According to ISO 8139 Intended for articulated mounting of the cylinder. This mounting is adjustable in the axial direction.	10	0.017	P1S-4CRT P1S-4DRT P1S-4HRT P1S-4JRT
		12-16	0.025	
		20	0.045	
		25	0.085	



Material:
Swivel rod eye: stainless steel, X5 CrNi 18-10 (AISI 304)
Ball: hardened stainless steel, X5 CrNi 18-10 (AISI 304)

Cylinder Ø mm	A mm	B	C	D	E	F	G	H	I	J	K	L
10	5	M4	2.2	8	10	9	27	6	8	33	9	2
12-16	6	M6	3.2	9	10	10	30	6.8	9	38.5	11	1.5
20	8	M8	4	12	12	12	36	9	12	46	14	2
25	10	M10x1.25	5	14	14	14	43	10.5	15	52.5	17	2.5

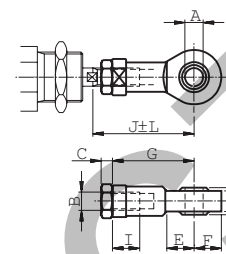

Stainless Rod nut MR9	Intended for fixed mounting on the piston rod. Cylinders are supplied complete with one rod nut. (cylinders with through piston rod are supplied with two rod nuts.)	10	0.001	P14-4CRPS P14-4DRPS P14-4HRPS P14-4KRPS
		12-16	0.002	
		20	0.005	
		25	0.007	



Material:
Stainless steel, X5 CrNi 18-10 (AISI 304)

Supplied in quantity pack of 10 off.

Cylinder Ø mm	D	F	E
10	M4	7	2.2
12-16	M6	10	3.2
20	M8	13	4
25	M10x1.25	17	5

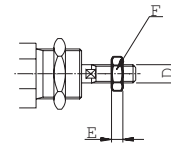

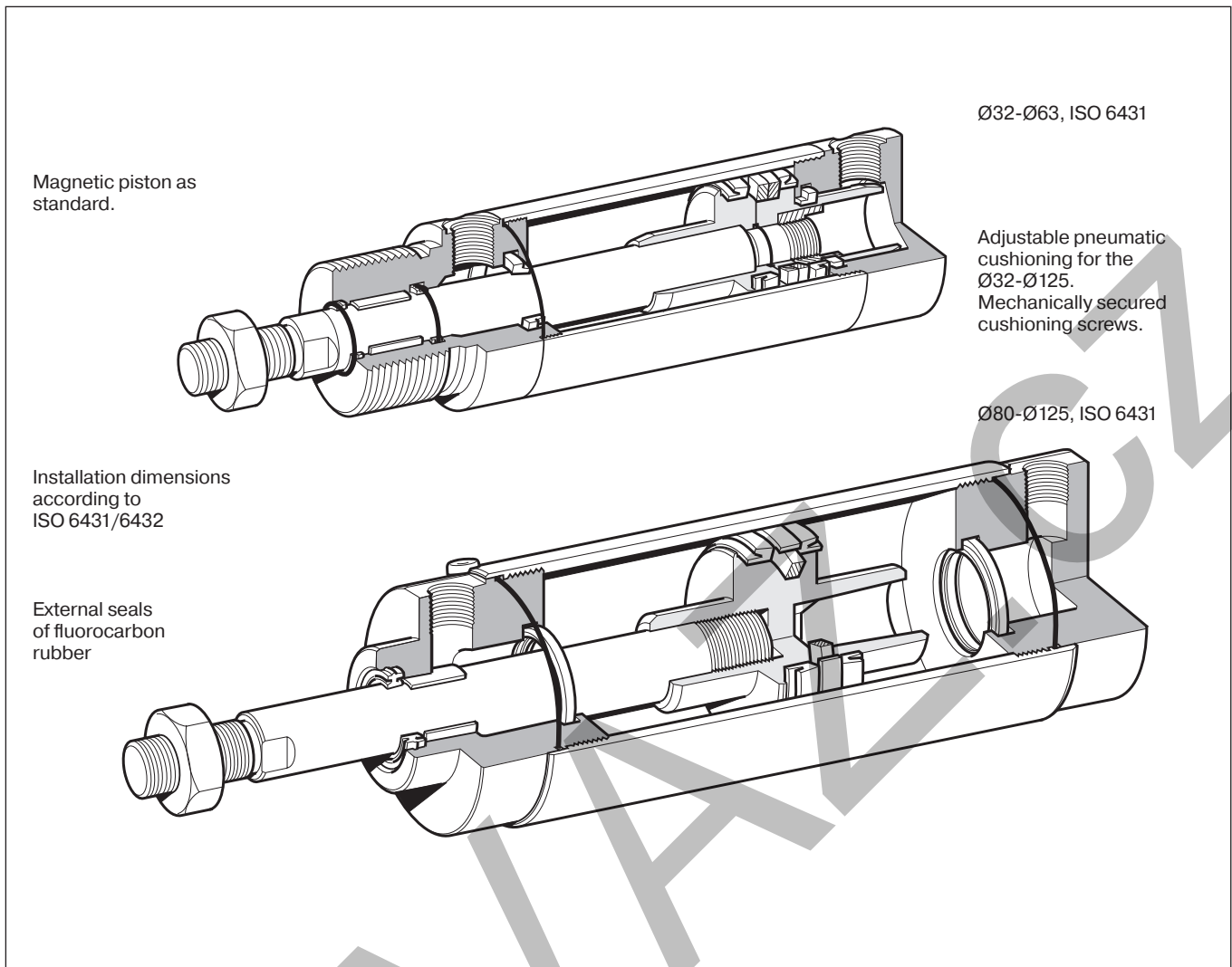

Stainless steel cylinders

Parker Pneumatic's range of stainless steel cylinders has been specially designed for use in difficult environments. Smooth design, external seals of fluorinated rubber and prelubrication with our food-industry-approved grease according to USDA-H1 make the cylinders particularly suitable for food industry use.

All cylinders have magnetic pistons for proximity position sensing. Fixing dimensions to ISO 6431/6432 simplify installation and make the cylinders physically interchangeable throughout the world.

ISO 6431

The ISO cylinders are double-acting round cylinders with several types of cylinder mountings as standard. The cylinders are available in 32 to 125 mm diameters, incorporating adjustable end-cushioning. As with the ISO 6432 it is designed to comply with hygiene requirements in accordance with the EU Machine Directive.

The cylinder can be dismantled to facilitate service and maintenance.

Main data: ISO 6431

Cylinder designation	Cylinder bore		Piston rod diam.	Piston rod area		Cushioning distance	Total mass at 0 mm stroke		Moving mass at 0 mm stroke		Air Consumption litres	Port thread
	mm	cm ²		cm ²	cm ²		kg	per 10 mm stroke	kg	per 10 mm stroke		
P1S-·032M	32	8.0	12	1.1	M10x1.25	15	0.59	0.026	0.10	0.009	0.105 ¹⁾	G1/8
P1S-·040M	40	12.6	16	2.0	M12x1.25	18	0.99	0.036	0.19	0.016	0.162 ¹⁾	G1/4
P1S-·050M	50	19.6	20	3.1	M16x1.5	19	1.63	0.057	0.32	0.024	0.253 ¹⁾	G1/4
P1S-·063M	63	31.2	20	3.1	M16x1.5	22	2.75	0.065	0.36	0.024	0.414 ¹⁾	G3/8
P1S-·080M	80	50.3	25	4.9	M20x1.5	24	5.09	0.099	1.11	0.039	0.669 ¹⁾	G3/8
P1S-·100M	100	78.5	25	4.9	M20x1.5	29	8.68	0.115	1.41	0.039	1.043 ¹⁾	G1/2
P1S-·125M	125	122.7	32	8.0	M27x2	32	15.31	0.174	2.90	0.063	1.662 ¹⁾	G1/2

1) Free air consumption per 10 mm stroke length for a double stroke at 600 kPa (6 bar)

Cylinder forces

Indicated cylinder forces are theoretical and should be reduced in relation to working conditions.

Cylinder designation	Theoretical cylinder force at 600 kPa (6 bar)	
	exp. stroke N	return stroke N
P1S-·032M	480	415
P1S-·040M	754	633
P1S-·050M	1180	990
P1S-·063M	1870	1680
P1S-·080M	3016	2721
P1S-·100M	4712	4417
P1S-·125M	7363	6880

Working medium, air quality

Working medium Dry, filtered compressed air to ISO 8573-1 class 3.4.3.

Recommended air quality for cylinders

For best possible service life and trouble-free operation, ISO 8573-1 quality class 3.4.3 should be used. This means 5 µm filter (standard filter) dew point +3 °C for indoor operation (a lower dew point should be selected for outdoor operation) and oil concentration 1.0 mg oil/m³, which is what a standard compressor with a standard filter gives.

ISO 8573-1 quality classes

Quality class	Pollution		Water max. press. dew point (°C)	Oil max concentration (mg/m ³)
	particle size (µm)	max concentration (mg/m ³)		
1	0.1	0.1	-70	0.01
2	1	1	-40	0.1
3	5	5	-20	1.0
4	15	8	+3	5.0
5	40	10	+7	25
6	-	-	+10	-

Additional data

Working pressure	max 10 bar
Working temperature	max +80 °C min -20 °C
High-temperature version	max +150 °C min -10 °C

Prelubricated, further lubrication is not normally necessary. If additional lubrication is introduced it must be continued.

Cushioning diagram

Use the diagram below to determine the necessary size of cylinder to provide the requisite cushioning performance. The maximum cushioning performance, as indicated in the diagram, is based on the following assumptions:

- Low load, i.e. low pressure drop across the piston
- Steady-state piston speed
- Correctly adjusted cushioning screw

The load is the sum of the internal and external friction, together with any gravity forces. At high relative loading it is recommended that, for a given speed, the load should be reduced by a factor of 2.5, or that, for a given mass, the speed should be reduced by a factor of 1.5. These factors

apply in relation to the maximum performance as shown in the diagram.

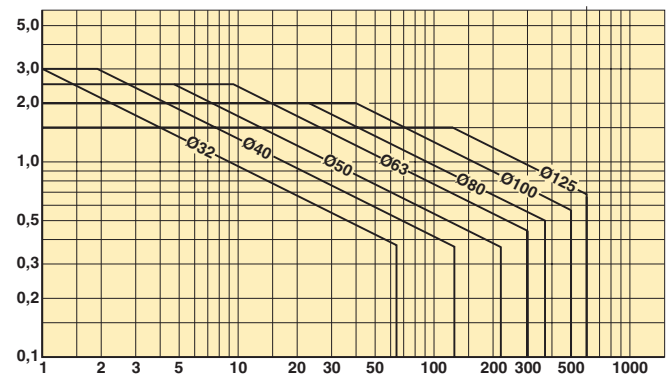

Speed [m/s]

Mass [kg]

Threaded front end

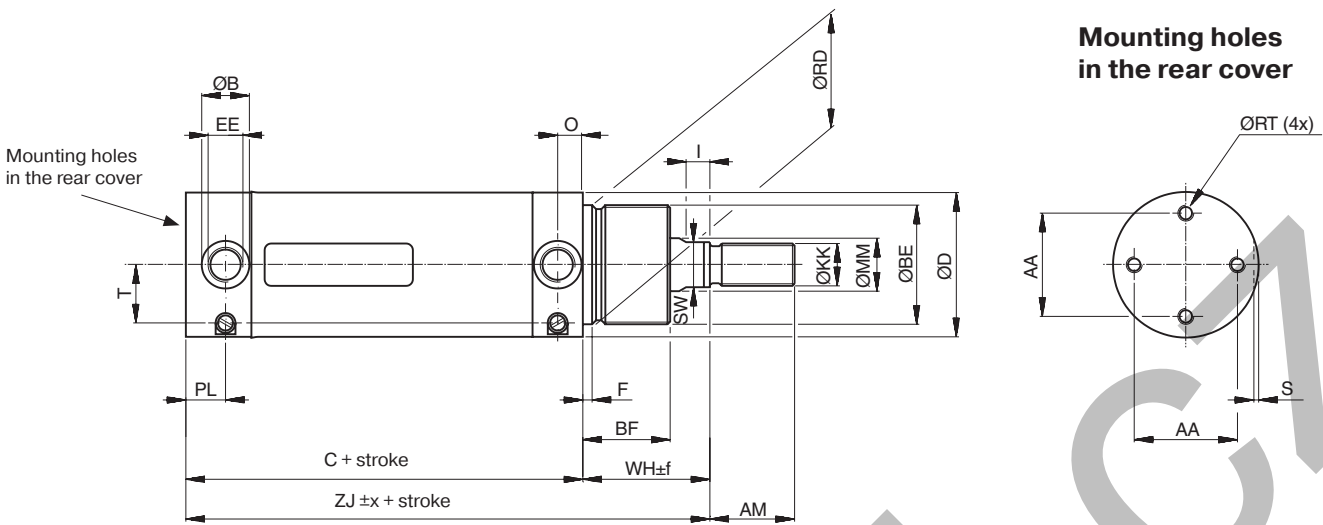

Basic cylinder

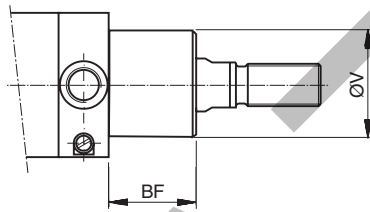

Dimensions Ø32 - Ø63

Cylinder designation	AA mm	AM mm	B mm	BF mm	BE mm	C mm	D mm	EE mm	F mm	I mm	KK mm	MM mm	O mm	PL mm	RD mm	RT mm	
P1S-D032M		24.5	22	15	25	M30x1.5	88	36	G1/8	4.2	6	M10x1.25	12	8	13	30	M5
P1S-D040M		30	24	18	30	M38x1.5	97	44	G1/4	4.5	9	M12x1.25	16	9.5	15	38	M6
P1S-D050M		39	32	18	33	M45x1.5	101	55	G1/4	4.5	9	M16x1.5	20	9.5	15	45	M6
P1S-D063M		49	32	25	33	M45x1.5	117	68	G3/8	4.5	9	M16x1.5	20	13.3	20.5	45	M8

Cylinder designation	S mm	SW mm	T mm	V mm	WH mm	ZJ mm	Mounting tolerances		Stroke length	
							x mm	f mm	0-500 mm	
P1S-D032M	1.5	10	12.2	26	35.5	123.5	1.2	2.5	+2.0	
P1S-D040M	1.5	14	16.5	35	44	141	1.0	2.2	+2.0	
P1S-D050M	1.5	17	22	41	47	148	0.9	2.3	+2.0	
P1S-D063M	1.5	17	26	41	47	164	1.4	2.3	+2.5	

Material specification Ø32 - Ø63

Piston rod	Stainless steel, X2 CrNiMo 17-13-2 (AISI 316L)
Piston rod nut	Stainless steel, X5 CrNi 18-10 (AISI 304)
Piston rod seal	UHMWPE-plastic/NBR
Scraper ring	UHMWPE-plastic/fluorocarbon rubber, FPM
Piston rod bearing	HDPE-plastic
End covers	Stainless steel, X5 CrNi 18-10 (AISI 304)
Cushioning screw	Stainless steel, X10 CrNiS 18-9 (AISI 303)
Cushioning screw lockings	Stainless steel, X5 CrNi 18-10 (AISI 304)
Cushioning sealing	NBR
O-ring, cushioning screw	Fluorocarbon, FPM
O-ring, internal	NBR
Cylinder barrel	Stainless steel, X5 CrNi 18-10 (AISI 304)
Piston	POM plastic
Piston seal	NBR
Piston nut	Zinc plated steel
Magnet	Plastic-coated magnetic material

Variants Ø32 - Ø63

High-temperature version, type F:

- Sealings/scraper ring fluorocarbon rubber, FPM
- Piston anodised aluminium

Basic cylinder

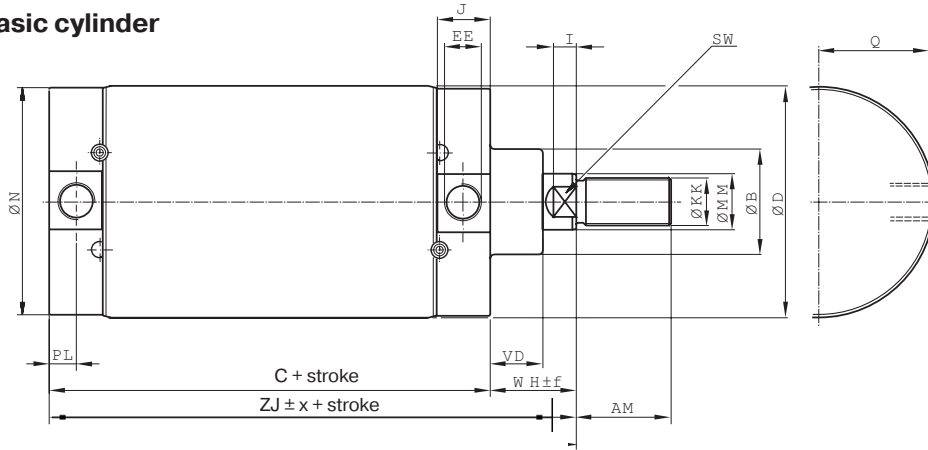

Threaded front end

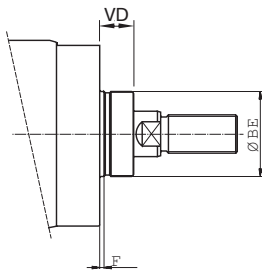

Mounting holes in the end covers (front and rear)

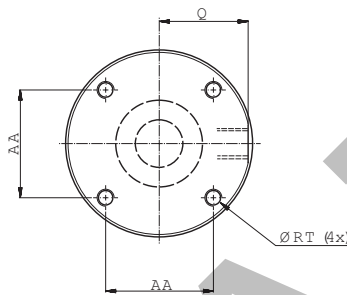

Dimensions Ø80 - Ø125

Cylinder designation	AA	AM	B	BE	C	D	EE	F	KK	I	J	MM	N	PL	Q	
	mm	mm	mm		mm	mm		mm		mm	mm	mm	mm	mm	mm	
P1S-·080M		46	40	50	M50x1.5	141	86	G3/8	4	M20x1.5	10	24.5	25	84	12.5	40
P1S-·100M		60	40	50	M50x1.5	158	106	G1/2	4	M20x1.5	8	25	104	15.5	49.5	
P1S-·125M		76	54	60	M60x2	183	133	G1/2	4	M27x2	13	32	129	15.5	62.5	

Cylinder designation	RT	SW	VD	WH	Mounting tol.		Stroke length	
	mm	mm	mm	mm	x	f	0-500 mm	
P1S-·080M		M8	21	19	37	1.5	2.5	+2.5
P1S-·100M		M10	21	19	35	1.5	2.5	+2.5
P1S-·125M		M12	27	24	47	2.0	2.5	+4.0

Material specification Ø80 - Ø125

Piston rod	Stainless steel, X2 CrNiMo 17-13-2 (AISI 316L)
Piston rod nut	Acid-proof steel, A4
Piston rod seal	FPM
Scraper ring	PTFE
Piston rod bearing	Multilayer PTFE and steel
End covers	Stainless steel, X5 CrNi 18-10 (AISI 304)
Cushioning screw	Stainless steel, X10 CrNiS 18-9 (AISI 303)
Cushioning sealing	NBR
O-ring, cushioning screw	Fluorocarbon, FPM
O-ring, internal	NBR
Cylinder barrel	Stainless steel, X5 CrNi 18-10 (AISI 304)
Piston	Anodised aluminium
Piston seal	NBR
Piston bearing	UHMWPE-plastic
Magnetic band	Rubber-coated magnetic material

Variants Ø80 - Ø125

High-temperature version, type F:

Sealings/scraper ring Fluorocarbon rubber, FPM/PTFE

P1S Series Stainless Steel Pneumatic Cylinders

Order key

P1S-D 032 M S - 0025

Cylinder version		Cylinder bore mm	Cylinder type/Function		Stroke in mm
C	Threaded front end		032	M	
D	Threaded front end + 4 mounting holes in the rear end cover	040			
E	Round front end cover + 4 mounting holes Ø 80 - Ø 125	050			
F	Round front end cover + 4 mounting holes the rear cover	063			
L	Round front end cover + 4 mounting holes in the front + 4 in the rear end covers Ø 80 - Ø 125	080			
		100			
		125			

Sealing material	
S	Standard, -20 °C to +80 °C Magnetic piston
F	High temperature, -10 °C to +150 °C Non magnetic piston

Stroke length

Cylinder designation	Cylinder bore	● Standard stroke length in mm according to ISO 4393											Non standard stroke length	
		25	50	80	100	125	160	200	250	320	400	500		
P1S--032M	32	●	●	●	●	●	●	●	●	●	●	●	●	●
P1S--040M	40	●	●	●	●	●	●	●	●	●	●	●	●	●
P1S--050M	50	●	●	●	●	●	●	●	●	●	●	●	●	●
P1S--063M	63	●	●	●	●	●	●	●	●	●	●	●	●	●
P1S--080M	80	●	●	●	●	●	●	●	●	●	●	●	●	●
P1S--100M	100	●	●	●	●	●	●	●	●	●	●	●	●	●
P1S--125M	125	●	●	●	●	●	●	●	●	●	●	●	●	●

All strokes in the range 25 - 1000 mm

P1S Series Stainless Steel Pneumatic Cylinders

Cylinder mountings Ø32 - Ø63

Type	Description	Cyl. bore Ø mm	Weight kg	Order code
Stainless clevis bracket MP4	Intended for articulated mounting of the cylinder versions D or F. The bracket is mounted at the rear end cover and is supplied complete with shaft, mounting screw and O-ring for a clean joint between end cover and bracket.	32	0.09	P1S-4KME P1S-4LME P1S-4MME P1S-4NME
		40	0.12	
		50	0.19	
		63	0.34	



Material:
Stainless steel, X5 CrNi 18-10 (AISI 304)

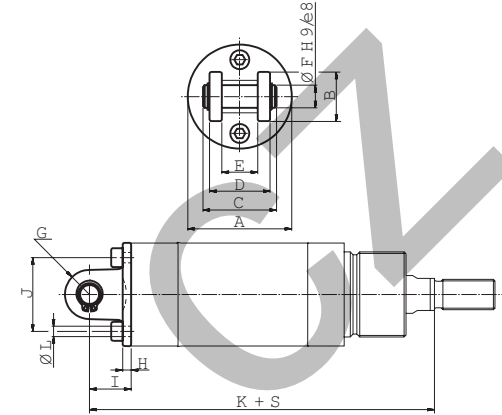

Cylinder Ø mm	A mm	B mm	C mm	D mm	E mm	F mm	G mm	H mm	I mm	J mm	K mm	L mm
32	35.5	20	33	26	15	10	10	4.5	18.5	25	142	5.5
40	43.5	24	35	28	17	12	12	4	19	30	160	6.5
50	54.5	26	39	32	17	12	13	4.5	22	39	170	6.5
63	67.5	34	47	40	22	16	17	6	26	49	190	8.6

S = Stroke

Type	Description	Cyl. bore Ø mm	Weight kg	Order code
Stainless neck nut MR3	Intended for fixed mounting of the cylinder via the neck.	32	0.03	9127294401 9127294402 9127294403
		40	0.06	
		50-63	0.08	



Material: stainless steel, X5 CrNi 18-10 (AISI 304)

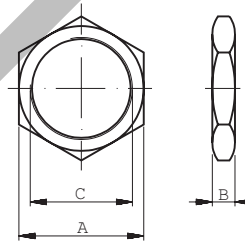

Cylinder Ø mm	A mm	B mm	C
32	36	8	M30x1.5
40	46	10	M38x1.5
50	55	10	M45x1.5
63	55	10	M45x1.5

Cylinder mountings Ø32 - Ø125

Type	Description	Cyl. bore Ø mm	Weight kg	Order code
Acid-proof rod nut MR9	Intended for fixed mounting on the piston rod. Cylinders are supplied complete with one rod nut. (cylinders with through piston rods are supplied with two rod nuts.)	32	0.007	P14-4KRPX P14-4LRPX P14-4MRPX P14-4MRPX P14-4PRPX P14-4PRPX P14-4RRPX
		40	0.010	
		50	0.021	
		63	0.021	
		80	0.040	
		100	0.040	
		125	0.100	



Material:
Acid-proof steel A4

Type	Description	Cyl. bore Ø mm	Weight kg	Order code
Stainless rod nut MR9	Intended for fixed mounting of accessories to the piston rod.	32	0.007	P14-4KRPS P14-4LRPS P14-4MRPS P14-4MRPS P14-4PRPS P14-4PRPS P14-4RRPS
		40	0.010	
		50	0.021	
		63	0.021	
		80	0.040	
		100	0.040	
		125	0.100	



Material:
Stainless steel, A2

Cylinder Ø mm	A mm	B mm	C
32	17	5	M10x1.25
40	19	6	M12x1.25
50	24	8	M16x1.5
63	24	8	M16x1.5
80	30	10	M20x1.5
100	30	10	M20x1.5
125	41	13.5	M27x2

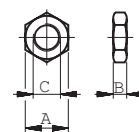

Supplied as pack of 10 off weight per item

Cylinder mountings

Type	Description	Cyl. bore Ø mm	Weight kg	Order code
Stainless flange MF1/MF2	Intended for fixed attachment of cylinder version D, E, F, or L. The flange is designed for mounting on the front or rear end covers. Material: Stainless steel, X3 CrNiMo 17-13-3 (AISI 316)	80	0.97	P1S-4PMB P1S-4QMB P1S-4RMB
		100	1.42	
		125	1.55	

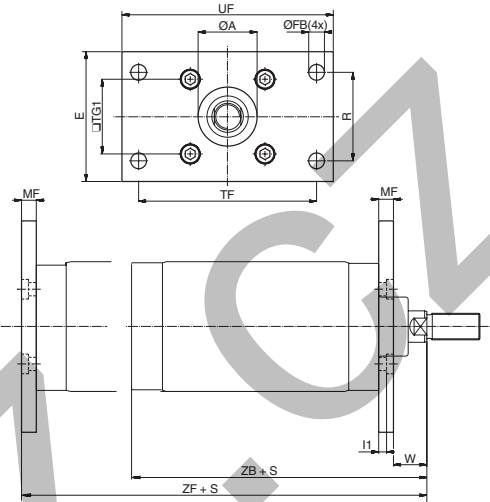

Cylinder Ø mm	A mm	FB mm	E mm	R mm	TF mm	TG1 mm	UF mm	MF mm	I1 mm	W mm	ZB mm	ZF mm
80	50.2	12	86	63	126	46	150	12	6	25	178	190
100	51	14	106	75	150	60	170	12	6	23	193	205
125	61	16	132	90	180	76	205	15	8	32	230	245

S = Stroke

Stainless clevis bracket MP4

Intended for articulated mounting of cylinder versions D, F or L. The bracket is mounted on the rear end cover and is supplied complete with shaft, mounting screw and O-ring for a clean joint between end cover and bracket.

Material:
Bracket: stainless steel, X5 CrNi 18-10 (AISI 304)
Pin: stainless steel, X3 CrNiMo 17-13-3 (AISI 316)



80	0.78	P1S-4PME P1S-4QME P1S-4RME
100	1.42	
125	2.06	

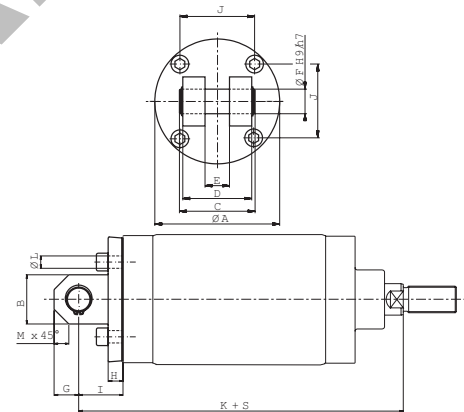

Cylinder Ø mm	A mm	B mm	C mm	D mm	E mm	F mm	G mm	H mm	I mm	J mm	K mm	L mm	M mm
80	80	30	57	50	16	16	15	12	32	46	210	8.6	9
100	103	42	67	60	20	20	21	12	37	60	230	10.6	12
125	127	50	77	70	25	25	25	15	45	76	275	12.6	15

S = Stroke

Stainless Neck nut MR3

Intended for fixed mounting on the front end cover of cylinders according to cylinder version C or D.

Material:
Stainless steel, X5 CrNi 18-10 (AISI 304)



80-100	0.16	9126461304 9126461305
125	0.19	

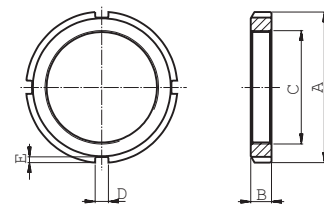

Cylinder Ø mm	A mm	B mm	C	D mm	E mm
80	70	11	M50x1.5	6	2.5
100	70	11	M50x1.5	6	2.5
125	80	11	M60x2	7	3

Cylinder mountings

Type	Description	Cyl. bore Ø mm	Weight kg	Order code
Combinated mounting MP2/MP4	Intended for articulated mounting of cylinder versions D, F or L. The unit is mounted on the rear end cover and is combined with bearing brackets MP2 and is supplied complete with shaft, mounting screw and O-ring for a clean joint between end cover and bracket.	80	1.29	P1S-4PML
		100	2.33	P1S-4QML
		125	3.30	P1S-4RML



Material:
 Bearing brackets: stainless steel, DIN X 5 CrNi 18 10
 Journal bearing: stainless steel,
 Journal bearing: DIN X 5 CrNiMo 17 13 3/PTFE
 Bracket: stainless steel, X5 CrNi 18-10 (AISI 304)
 Pin: stainless steel, X3 CrNiMo 17-13-3 (AISI 316)

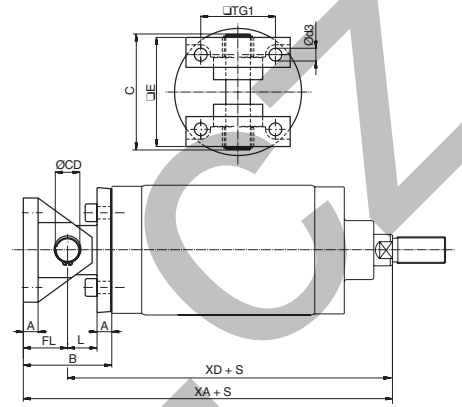

Cylinder Ø mm	A mm	B mm	C mm	CD mm	d3 mm	E mm	FL mm	L mm	TG1 mm	XA mm	XD mm
80	12	64	82	16	9	74	32	20	46	242	210
100	12	74	98	20	11	90	37	25	60	267	230
125	15	90	118	25	13	110	45	30	76	320	275

S = Stroke

KONVA

P1S Series Stainless Steel Pneumatic Cylinders

Cylinder mountings Ø32 - Ø125

Type Description

Stainless swivel rod eye AP6



According to ISO 8139
Intended for articulated mounting of the cylinder.
This mounting is adjustable in the axial direction.

Material:
Swivel rod eye: stainless steel, X5 CrNi 18-10 (AISI 304)
Ball: hardened stainless steel, X5 CrNi 18-10 (AISI 304)

Cyl. bore
Ø mm

Weight
kg

Order code

32
40
50-63
80-100
125

0.08
0.12
0.25
0.46
1.28

P1S-4JRT
P1S-4LRT
P1S-4MR
P1S-4PRT
P1S-4RRT

Cyl. Ø mm	A mm	B _{min} mm	B _{max} mm	C mm	D mm	E mm	F mm	G mm	H mm	I mm	K mm	L	M
32	28	50	55	10	15	43	14	15	14	10.5	17	M10x1.25	24°
40	32	56	62	12	17	50	16	22	16	12	19	M12x1.25	24°
50	42	72	80	16	22	64	21	28	21	15	22	M16x1.5	30°
63	42	72	80	16	22	64	21	28	21	15	22	M16x1.5	30°
80	50	87	97	20	26	77	25	33	25	18	32	M20x1.5	30°
100	50	87	97	20	26	77	25	33	25	18	32	M20x1.5	30°
125	70	123.5	137	30	36	110	35	51	37	25	41	M27x2	30°

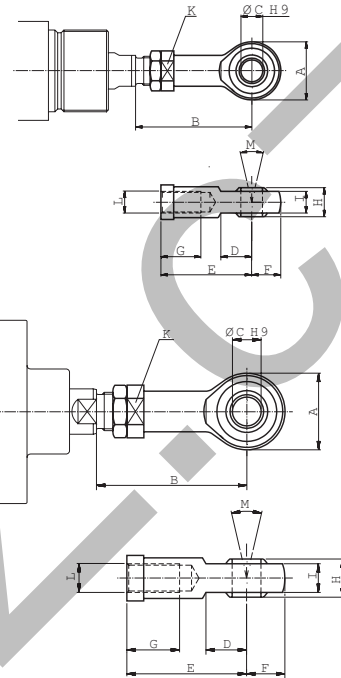

Stainless clevis AP2



According to ISO 8140
Intended for articulated mounting of the cylinder. This mounting is adjustable in the axial direction. Supplied complete with pin.

Material:
Clevis: stainless steel, X10 CrNiS 18-9 (AISI 303)
Pin: stainless steel, X5 CrNi 18-10 (AISI 304)
Locking rings according to DIN 471

32
40
50-63
80-100
125

0.09
0.15
0.35
0.75
2.10

P1S-4JRD
P1S-4LRD
P1S-4MRD
P1S-4PRD
P1S-4RRD

Cylinder Ø mm	A mm	B _{min} mm	B _{max} mm	C mm	D mm	E mm	F mm	G mm	H mm	I
32	20	46	52	10	20	40	12	28	10	M10x1.25
40	24	54	60	12	24	48	19	32	12	M12x1.25
50	32	72	80	16	32	64	25	42	16	M16x1.5
63	32	72	80	16	32	64	25	42	16	M16x1.5
80	40	90	100	20	40	80	32	50	20	M20x1.5
100	40	90	100	20	40	80	32	50	20	M20x1.5
125	55	123.5	137	30	54	110	45	72	30	M27x2

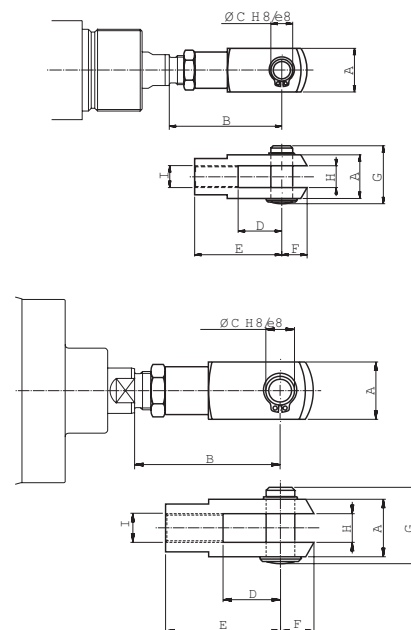

P1S Series Stainless Steel Pneumatic Cylinders

Seal kits for P1S cylinders

Complete seal kits consisting of:

- Piston seals
- Cushioning seals
- Piston rod bearing
- Piston rod seal
- Scraper ring
- O-rings

Material specification, see pages 19 and 20.

Standard temperature versions

Cylinder designation	Order code
P1S-·032MS	9121659195
P1S-·040MS	9121659196
P1S-·050MS	9121659197
P1S-·063MS	9121659198
P1S-·080MS	9121718905
P1S-·100MS	9121718906
P1S-·125MS	9121718907

High temperature versions

Cylinder designation	Order code
P1S-·032MF	9121720595
P1S-·040MF	9121720596
P1S-·050MF	9121720597
P1S-·063MF	9121720598
P1S-·080MF	9121718925
P1S-·100MF	9121718926
P1S-·125MF	9121718927

Standard temperature with Through rod

Cylinder designation	Order code
P1S-·080FS	9121718955
P1S-·100FS	9121718956
P1S-·125FS	9121718957

Standard temperature with stainless steel scraping ring

Cylinder designation	Order code
P1S-·080MQ	9121718915
P1S-·100MQ	9121718916
P1S-·125MQ	9121718917

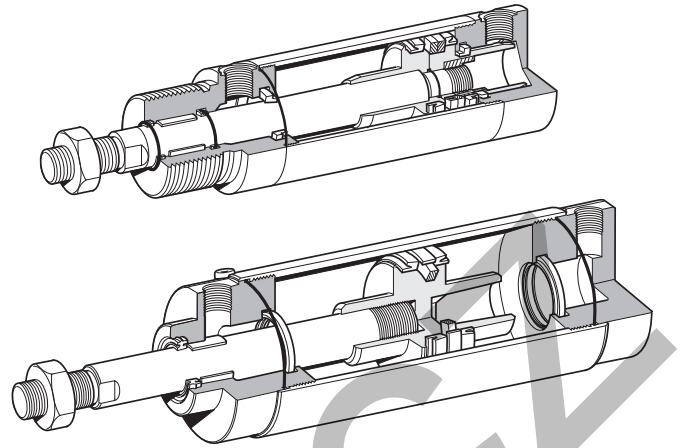

Grease

Version	Weight	Order code
Standard and Low temperature	30 g	9127394541
High temperature	30 g	9127394521

P8S Electronic and Reed Sensors

The P8S Series magnetic cylinder sensor enables quick, precise and contactless sensing of the piston's position in cylinders. It is easy to mount, can be used in numerous applications and offers an outstanding price-performance ratio.



Product Overview

As the term magnetic switch suggests, these are operated by magnetic fields; another description widely used is magnetic „SENSOR“. As our eyes sense change of light, our ears sense the change of sound, magnetic sensors / switches sense the change of magnetic flux in pneumatic and hydraulic cylinders. When magnetic sensors sense a magnetic field it will give a switching signal, through a control circuit, allowing sensing or control operation to be achieved.

Because of the characteristics of magnetic sensors they can sense a change of magnetic field relative to the position of the magnet, such as in a pneumatic or hydraulic cylinder, whereby the magnet is attached to a moving piston and thus the position of the moving part (ie Piston) can be detected.

The magnet is mounted on the piston of the cylinder and thus moves with the piston.

The magnetic sensor (switch) is fixed either directly to the cylinder or with an additional mounting bracket. When the piston (magnet) moves to the position under a magnetic sensor, the switch will operate due to the change of the magnetic field and give a switching signal.

Thus the position of the piston can be identified and a resulting signal generated to continue the sequence of a circuit.

Magnetic sensors available can be classified into two different groups, they are sensors with contacts which are called mechanically operated or reed sensors and the other type is sensors without contacts and are called solid state type or electronic.

Parker P8S Series sensors are suitable for use with a large range of Sensors. They can either be inserted directly into the cylinder tube extrusion or mounted using additional brackets. For direct mounting the sensor is positioned within the cylinder sensor groove, offering mechanical protection, then securely clamped into position by a simple turn of a screw. For other cylinder versions there are a number of optional sensors brackets that clamp to the cylinder and offer other mounting positions. To easy installation there

are several cable lengths available with either M8 connector or flying lead. The electronic sensors are "Solid State", i.e. they have no moving parts. They are provided with short-circuit protection and transient protection as standard. The built-in electronics make the sensors suitable for applications with high on and off switching frequency where long service life is required.

Please note that for low temperature applications sensors are normally specified for full performance down to -30°C only. High temperature cylinders do not have a magnetic piston and therefore cannot be used with sensors.

P1S Series Stainless Steel Pneumatic Cylinders

Technical Data

Square body design, insert straight in T-slot, screw 1/4 turn

	Electronic PNP NPN	Electric Reed
Cylinder type:	Profile with T-slot	
Cylinder type with adaptor:	Profile with S-slot (dovetail) Tie rods Round cylinders	
Installation:	Quarter turn, fixed by allen key 2.5 mm or flathead screwdriver	
Housing length:	29.5 mm 10 - 30 V DC	29.5 mm 5 - 30 V AC/DC
	24 mm NAMUR	29.5 mm 5 - 120 V AC/DC
	29.5 mm ATEX	32.5 mm 5 - 230 V AC/DC
Output Type:	PNP NPN	Reed
Switching (on/off) switching frequency:	± 1,000 Hz	± 400 Hz
Output Function:	Normally Open (NO) Normally Closed (NC) 3-wire	Normally Open (NO) Normally Closed (NC) 2-wire Normally Open (NO) 3-wire
Enclosure rating:	IP67	
	IP67 (NAMUR ATEX)	
Supply Voltage:	10 to 30 V DC	
	8.2 to 20 V DC (NAMUR 1GD) 10 to 26 V DC (ATEX 3GD)	5 to 30 5 to 120 5 to 230 V AC/DC 2-wire, 3-wire depending on type
Power consumption:	<= 8 mA	-
	<= 10 mA (NAMUR, ATEX)	-
Voltage drop:	<= 2 V	<= 3.5 V 2-wire <= 0.1 V 3-wire
	<= 2.2 V (NAMUR, ATEX)	-
Continuous output current I_a:	<= 100 mA	<= 100 mA 3-wire
	<= 60 mA (NAMUR) <= 50 mA (ATEX)	<= 500 mA (DC) <= 300 mA (AC)
Switching capacity:	-	<= 6 W
Protection class:	III	III II 2-wire depending on type
		III 3-wire
Response sensitivity:	2.6 to 3.3 mT	2.1 to 3.4 mT
	2.8 mT (NAMUR, ATEX)	-
Overrun distance:		10 mm
	9 mm (NAMUR, ATEX)	-
Hysteresis:	<= 0.8 mT	-
	<= 0.5 mT (NAMUR, ATEX)	-
Repeatability:		<= 0.1 mT
Reverse polarity protection:	Yes	No 2-wire
	-	Yes 3-wire
Short circuit protection:	Yes	-
Power-up pulse protection:	Yes (NAMUR, ATEX)	-
Ambiant operating temperature range:	-30 to +80 °C (PUR cable) -30 to +70°C (PVC cable)	
	-25 to +80 °C (NAMUR 1GD) -20 to +50°C (ATEX 3GD)	
Shock and vibration resistance:	30 g 11 ms / 10 ... 55 Hz, 1 mm	
EMC:	According to EN 60947-5-2	
International standard:	CE C UL US RoHs Ex IEC IEC Ex	
Housing material:	Plastic polyamid PA12	
Screw material:	Stainless steel	
Cable material:	PUR (Polyurethane) PVC (Polyvinyl Chloride)	
Conductor cross-section:	0.14 mm ² 0,12 mm ² depending on type 0.14 mm ² (NAMUR, ATEX)	
Indication LED colour:	Yellow, no LED reed NC	
Connector:	M8R (knurled nuts) None (Flying lead)	

P1S Series Stainless Steel Pneumatic Cylinders

Dimensions in mm (inch)

PNP, NPN Output 10 to 30 V DC

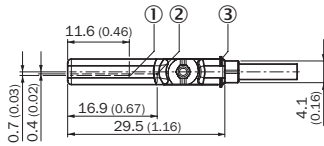
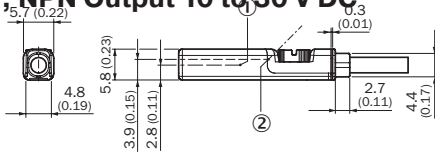

- ① Position sensor element
- ② Indication LED
- ③ Retaining ribs

Reed Output 5 to 230V AC/DC

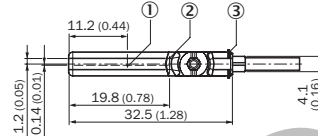
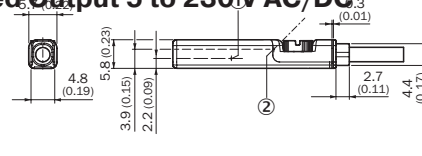

- ① Position sensor element
- ② Indication LED
- ③ Retaining ribs

Reed Output 5 to 30 V AC/DC

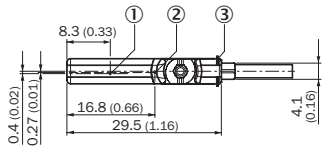
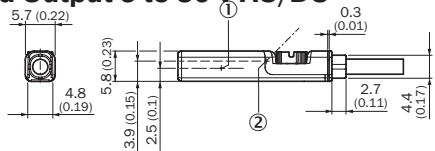

- ① Position sensor element
- ② Indication LED
- ③ Retaining ribs

Reed Output 5 to 120 V AC/DC

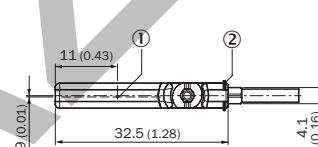
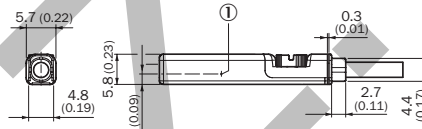

- ① Position sensor element
- ② Retaining ribs

NAMUR 1G, 1D,

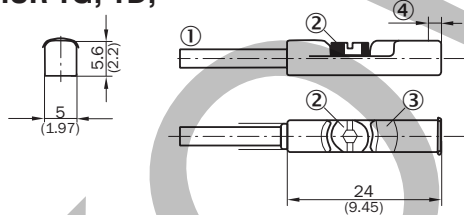

- ① Connection
- ② Fixing screw
- ③ Indication LED
- ④ Position of sensor element; short overrun distance: 2 mm; long overrun distance: 1.7 mm

Connector M8R

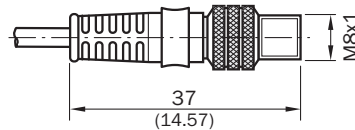

Dimensions in mm (inch)

P8S-TMC01, 02 & 03

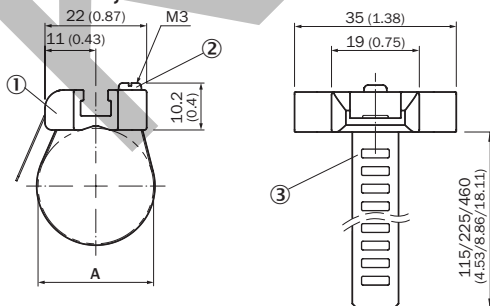

- ① Sensoradapter with T-slot
- ② Fixing screw
- ③ Strap

Order Code	A [mm]	
P8S-TMC01	8 to 25	Clamping ring in nickel silver,
P8S-TMC02	32 to 63	screw in stainless steel,
P8S-TMC03	80 to 130	sensor mounting zinc diecast

P1S Series Stainless Steel Pneumatic Cylinders

Connection type and diagram

PNP NO

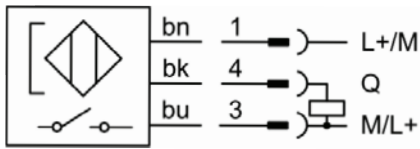

PNP NC

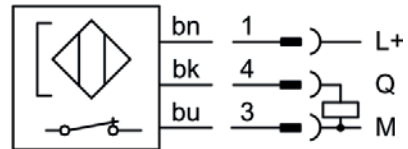

NPN NO

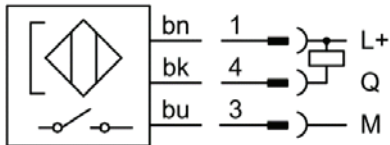

NPN NC

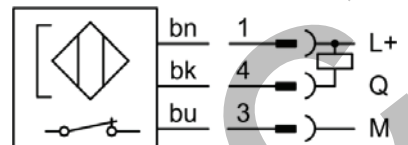

Reed NO 3-wire

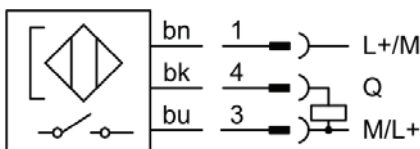

bn: brown
 bk: black
 bu: blue
 Q: load
 M: Mass
 L+: Power

Reed NO 2-wire

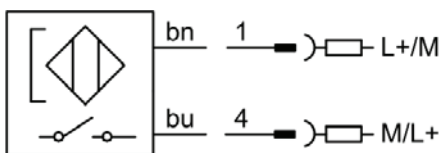

Reed NC 2-wire

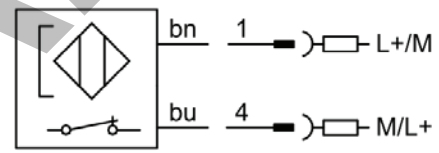

NAMUR NO ATEX 1G, 1D

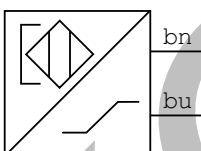

PNP NO ATEX 3G, 3D

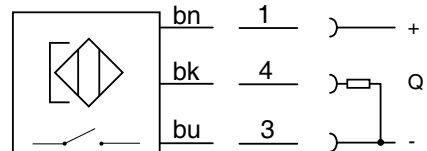

Pin assignment, M8 with knurled nut

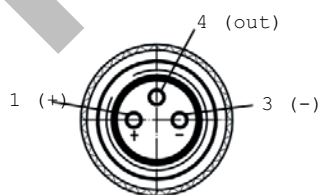

Flying leads

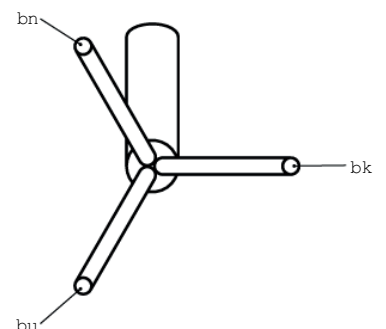

P1S Series Stainless Steel Pneumatic Cylinders

Ordering Data

Square body design, instert straight in T-slot, screw 1/4 turn

Output, Function, Cable & Supply Voltage	Order Code	Weight [g]	For Product Series
With flying leads, PUR cable IP67			
Electronic PNP-NC, with LED, 3-wire, 3 meter, 10-30 V DC	P8SAGQFAX	35	All Series
Electronic PNP-NC, with LED, 3-wire, 10 meter, 10-30 V DC	P8SAGQFDX	105	All Series
Electronic PNP-NO, with LED, 3-wire, 3 meter, 10-30 V DC	P8SAGPFAX	35	All Series
Electronic PNP-NO, with LED, 3-wire, 10 meter, 10-30 V DC	P8SAGPFDX	105	All Series
Electronic NPN-NC, with LED, 3-wire, 3 meter, 10-30 V DC	P8SAGMFAX	35	All Series
Electronic NPN-NC, with LED, 3-wire, 10 meter, 10-30 V DC	P8SAGMFDX	105	All Series
Electronic NPN-NO, with LED, 3-wire, 3 meter, 10-30 V DC	P8SAGNFAX	35	All Series
Electronic NPN-NO, with LED, 3-wire, 10 meter, 10-30 V DC	P8SAGNFDX	105	All Series
Electric Reed-NO, with LED, 3-wire, 3 meter, 5-30 V AC/DC	P8SAGSFAX	35	All Series
Electric Reed-NO, with LED, 3-wire, 10 meter, 5-30 V AC/DC	P8SAGSFDX	105	All Series
Electric Reed-NO, with LED, 2-wire, 3 meter, 5-30 V AC/DC	P8SAGRFAFX	35	All Series
Electric Reed-NO, with LED, 2-wire, 10 meter, 5-230 V AC/DC	P8SAGRFDX2	105	All Series
Electric Reed-NC, No LED, 2-wire, 10 meter, 5-120 V AC/DC	P8SAGEFRX1	105	All Series
Electric Reed-NC, No LED, 2 wire, 10 meter, 5-30V AC/DC	P8SSAGEFRX	105	All Series
With flying leads, PVC cable IP67			
Electric Reed-NO, with LED, 3-wire, 3 meter, 5-30 V AC/DC	P8SAGSFLX	35	All Series
Electric Reed-NO, with LED, 2-wire, 3 meter, 5-120 V AC/DC	P8SAGRFLX1	35	All Series
Electric Reed-NO, with LED, 2-wire, 3 meter, 5-230 V AC/DC	P8SAGRFLX2	35	All Series
Electronic PNP-NC, with LED, 3-wire, 3 meter, 10-30 V DC	P8SAGQFLX	35	All Series
Electronic PNP-NO, with LED, 3-wire, 3 meter, 10-30 V DC	P8SAGPFLX	35	All Series
Electronic PNP-NO, with LED, 3-wire, 10 meter, 10-30 V DC	P8SAGPFTX	105	All Series
Electric Reed-NO, with LED, 2-wire, 10 meter, 5-120 V AC/DC	P8SAGRFTX1	105	All Series
Electric Reed-NO, with LED, 3-wire, 10 meter, 10-30 V AC/DC	P8SAGSFTX	105	All Series
With M8 knurled screw, PUR cable IP67			
Electronic PNP-NC, with LED, 3-wire, 0,3 meter, 10-30 V DC	P8SAGQCHX	15	All Series
Electronic PNP-NO, with LED, 3-wire, 0,3 meter, 10-30 V DC	P8SAGPCHX	15	All Series
Electronic NPN-NC, with LED, 3-wire, 0,3 meter, 10-30 V DC	P8SAGMCHX	15	All Series
Electronic NPN-NO, with LED, 3-wire, 0,3 meter, 10-30 V DC	P8SAGNCHX	15	All Series
Electric Reed-NO, with LED, 3-wire, 0,3 meter, 5-30 V AC/DC	P8SAGSCHX	15	All Series
Electric Reed-NC, No LED, 2-wire, 0,3 meter, 5-30 V AC/DC	P8SAGECNX	15	All Series
Electric Reed-NO, with LED, 2-wire, 0,3 meter, 5-30 V AC/DC	P8SAGRCHX	15	All Series
For ATEX IP67			
Electronic PNP-NO, with LED, 3-wire, 3 meter, 10-26 V DC, PUR	P8SAGPFAXS	35	ATEX Series 3G, 3D
NAMUR-NO, with LED, 2-wire, 5 meter, 8,2-20 V DC, PVC	P8SAGDFMXW	55	ATEX Series 1G, 1D
NAMUR-NO, with LED, 2-wire, 10 meter, 8,2-20 V DC, PVC	P8SAGDFTXW	105	ATEX Series 1G, 1D

Note:

-30 to +80 °C (PUR cable) | -30 to +70 °C (PVC cable) | -25 to +80 °C (NAMUR 1GD) | -20 to +50 °C (ATEX 3GD)

All sensors are with an adaptor for S-dovetail Parker type OSP grooves.

* with an aluminium adaptor

P1S Series Stainless Steel Pneumatic Cylinders

Male connectors for connecting cables

Cable connectors for producing your own connecting cables. The connectors can be quickly attached to the cable without special tools. Only the outer sheath of the cable is removed. The connectors are available for M8 screw connector and meet protection class IP65.

Technical Data

Operating voltage:	max. 32 V AC/DC
Operating current per contact:	max. 4 A
Connection cross section:	0.25... 0.5 mm ² (conductor diameter min 0.1 mm)
Protection class:	IP65 and IP67 when plugged and screwed down (EN 60529)
Temperature range:	- 25... + 85°C

Connector	Weight [kg]	Order Code
M8 screw connector		P8CS0803J
M12 screw connector	0.022	P8CS1204J



Cables to extend cable sensor lengths with M8*

Description	Order Code	Weight [g]	For Product Series
Cable flex PVC 3 meter with 8mm snap-in connector / flying leads	9126344341	70	P8S Sensors with M8
Cable flex PVC 10 meter with 8mm snap-in connector / flying leads	9126344342	210	P8S Sensors with M8
Cable PUR 3 meter with 8mm snap-in female connector / flying leads	9126344345	70	P8S Sensors with M8
Cable flex PUR 10 meter with 8mm snap-in connector / flying leads	9126344346	210	P8S Sensors with M8
Cable PVC 2.5 meter with M8 screw connector / flying leads	KC3102	60	P8S Sensors with knurled M8
Cable PVC 5 meter with M8 screw female connector / flying leads	KC3104	120	P8S Sensors with knurled M8

*Note: not applicable for P8S CPS Sensors as no cable available

Specifying air quality (purity) in accordance with ISO8573-1:2010, the international standard for compressed air quality

ISO8573-1 is the primary document used from the ISO8573 series as it is this document which specifies the amount of contamination allowed in each cubic metre of compressed air.

ISO8573-1 lists the main contaminants as Solid Particulate, Water and Oil. The purity levels for each contaminant are shown separately in tabular form, however for ease of use, this document combines all three contaminants into one easy to use table.

ISO8573-1:2010 CLASS	Solid Particulate			Mass Concentration mg/m ³	Water		Oil
	Maximum number of particles per m ³				Vapour Pressure Dewpoint	Liquid g/m ³	Total Oil (aerosol liquid and vapour)
	0,1 - 0,5 micron	0,5 - 1 micron	1 - 5 micron				mg/m ³
0	As specified by the equipment user or supplier and more stringent than Class 1						
1	≤ 20 000	≤ 400	≤ 10	-	≤ -70 °C	-	0,01
2	≤ 400 000	≤ 6 000	≤ 100	-	≤ -40 °C	-	0,1
3	-	≤ 90 000	≤ 1 000	-	≤ -20 °C	-	1
4	-	-	≤ 10 000	-	≤ +3 °C	-	5
5	-	-	≤ 100 000	-	≤ +7 °C	-	-
6	-	-	-	≤ 5	≤ +10 °C	-	-
7	-	-	-	5 - 10	-	≤ 0,5	-
8	-	-	-	-	-	0,5 - 5	-
9	-	-	-	-	-	5 - 10	-
X	-	-	-	> 10	-	> 10	> 10

Specifying air purity in accordance with ISO8573-1:2010

When specifying the purity of air required, the standard must always be referenced, followed by the purity class selected for each contaminant (a different purity class can be selected for each contamination if required).

An example of how to write an air quality specification is shown below:

ISO 8573-1:2010 Class 1.2.1

ISO 8573-1:2010 refers to the standard document and its revision, the three digits refer to the purity classifications selected for solid particulate, water and total oil. Selecting an air purity class of 1.2.1 would specify the following air quality when operating at the standard's reference conditions:

Class 1 - Particulate

In each cubic metre of compressed air, the particulate count should not exceed 20,000 particles in the 0.1 - 0.5 micron size range, 400 particles in the 0.5 - 1 micron size range and 10 particles in the 1 - 5 micron size range.

Class 2 - Water

A pressure dewpoint (PDP) of -40°C or better is required and no liquid water is allowed.

Class 1 - Oil

In each cubic metre of compressed air, not more than 0.01mg of oil is allowed. This is a total level for liquid oil, oil aerosol and oil vapour.

ISO8573-1:2010 Class zero

- **Class 0 does not mean zero contamination.**
- **Class 0 requires the user and the equipment manufacturer to agree contamination levels as part of a written specification.**
- **The agreed contamination levels for a Class 0 specification should be within the measurement capabilities of the test equipment and test methods shown in ISO8573 Pt 2 to Pt 9.**
- **The agreed Class 0 specification must be written on all documentation to be in accordance with the standard.**
- **Stating Class 0 without the agreed specification is meaningless and not in accordance with the standard.**
- **A number of compressor manufacturers claim that the delivered air from their oil-free compressors is in compliance with Class 0.**
- **If the compressor was tested in clean room conditions, the contamination detected at the outlet will be minimal. Should the same compressor now be installed in typical urban environment, the level of contamination will be dependent upon what is drawn into the compressor intake, rendering the Class 0 claim invalid.**
- **A compressor delivering air to Class 0 will still require purification equipment in both the compressor room and at the point of use for the Class 0 purity to be maintained at the application.**
- **Air for critical applications such as breathing, medical, food, etc typically only requires air quality to Class 2.2.1 or Class 2.1.1.**
- **Purification of air to meet a Class 0 specification is only cost effective if carried out at the point of use.**

KOLVANZ.CZ

Parker Worldwide

Europe, Middle East, Africa

AE – United Arab Emirates,
Dubai
Tel: +971 4 8127100

AT – Austria, St. Florian
Tel: +43 (0)7224 66201

BE/NL/LU – Benelux,
Hendrik Ido Ambacht
Tel: +31 (0)541 585 000

BY – Belarus, Minsk
Tel: +48 (0)22 573 24 00

CH – Switzerland, Etoy
Tel: +41 (0)21 821 87 00

CZ – Czech Republic,
Prague
Tel: +420 284 083 111

DE – Germany, Kaarst
Tel: +49 (0)2131 4016 0

DK – Denmark, Ballerup
Tel: +45 43 56 04 00

ES – Spain, Madrid
Tel: +34 902 330 001

FI – Finland, Vantaa
Tel: +358 (0)20 753 2500

FR – France, Contamine s/Arve
Tel: +33 (0)4 50 25 80 25

HU – Hungary, Budaörs
Tel: +36 23 885 470

IE – Ireland, Dublin
Tel: +353 (0)1 466 6370

IL – Israel
Tel: +39 02 45 19 21

IT – Italy, Corsico (MI)
Tel: +39 02 45 19 21

NO – Norway, Asker
Tel: +47 66 75 34 00

PL – Poland, Warsaw
Tel: +48 (0)22 573 24 00

PT – Portugal
Tel: +351 22 999 7360

RO – Romania, Bucharest
Tel: +40 21 252 1382

RU – Russia, Moscow
Tel: +7 495 645-2156

SE – Sweden, Borås
Tel: +46 (0)8 59 79 50 00

SL – Slovenia, Novo Mesto
Tel: +386 7 337 6650

TR – Turkey, Istanbul
Tel: +90 216 4997081

UK – United Kingdom, Warwick
Tel: +44 (0)1926 317 878

ZA – South Africa, Kempton Park
Tel: +27 (0)11 961 0700

North America

CA – Canada, Milton, Ontario
Tel: +1 905 693 3000

US – USA, Cleveland
Tel: +1 216 896 3000

Asia Pacific

AU – Australia, Castle Hill
Tel: +61 (0)2-9634 7777

CN – China, Shanghai
Tel: +86 21 2899 5000

HK – Hong Kong
Tel: +852 2428 8008

IN – India, Mumbai
Tel: +91 22 6513 7081-85

JP – Japan, Tokyo
Tel: +81 (0)3 6408 3901

KR – South Korea, Seoul
Tel: +82 2 559 0400

MY – Malaysia, Shah Alam
Tel: +60 3 7849 0800

NZ – New Zealand, Mt Wellington
Tel: +64 9 574 1744

SG – Singapore
Tel: +65 6887 6300

TH – Thailand, Bangkok
Tel: +662 186 7000

TW – Taiwan, Taipei
Tel: +886 2 2298 8987

South America

AR – Argentina, Buenos Aires
Tel: +54 3327 44 4129

BR – Brazil, Sao Jose dos Campos
Tel: +55 080 0727 5374

CL – Chile, Santiago
Tel: +56 22 303 9640

MX – Mexico, Toluca
Tel: +52 72 2275 4200

EMEA Product Information Centre
Free phone: 00 800 27 27 5374
(from AT, BE, CH, CZ, DE, DK, EE, ES, FI, FR, IE, IL,
IS, IT, LU, MT, NL, NO, PL, PT, RU, SE, SK, UK, ZA)

US Product Information Centre
Toll-free number: 1-800-27 27 537

www.parker.com

