



aerospace  
climate control  
electromechanical  
filtration  
fluid & gas handling  
hydraulics  
**pneumatics**  
process control  
sealing & shielding



## Rotary Actuators

Series VRS / VRA

Sizes 32, 40, 50, 63, 80, 100 & 125mm

Rotation 96°, 186° and 366°

Catalogue PDE2655TCUK June 2013



ENGINEERING YOUR SUCCESS.



- Transforms the rectilinear motion of 2 single acting opposite cylinders into rotary motion via a rack and pinion drive contained within the cylinder body.
- Various tasks can be handled by use of a torque cylinder, including gate opening and closing, clamping and agitation of fluids and raw materials.
- Key points of the VRS / VRA cylinder design
  - lightweight materials (aluminium alloy)
  - accuracy in motion (cushioning, clearance compensation - bores up to 80mm)
  - long life (floating piston, nitrile seals, adjustable cushions)
  - good resistance to corrosion
  - easy cleaning (extruded body)
- Operates with dry, lubricated or non lubricated air
- The range includes bores from  $\text{Ø}32$  to 125mm with rotative angles of  $96^\circ$ ,  $186^\circ$  and  $366^\circ$
- Magnetic piston versions can be fitted with P8S sensors and brackets
- Several options are available; rotative angle adjustable stop, male shaft or female shaft (through)

 **WARNING**

**FAILURE OR IMPROPER SELECTION OR IMPROPER USE OF THE PRODUCTS AND/OR SYSTEMS DESCRIBED HEREIN OR RELATED ITEMS CAN CAUSE DEATH, PERSONAL INJURY AND PROPERTY DAMAGE.**

This document and other information from Parker Hannifin Corporation, its subsidiaries and authorized distributors provide product and/or system options for further investigation by users having technical expertise. It is important that you analyze all aspects of your application and review the information concerning the product or system in the current product catalog. Due to the variety of operating conditions and applications for these products or systems, the user, through its own analysis and testing, is solely responsible for making the final selection of the products and systems and assuring that all performance, safety and warning requirements of the application are met. The products described herein, including without limitation, product features, specifications, designs, availability and pricing, are subject to change by Parker Hannifin Corporation and its subsidiaries at any time without notice.

**SALE CONDITIONS**

The items described in this document are available for sale by Parker Hannifin Corporation, its subsidiaries or its authorized distributors. Any sale contract entered into by Parker will be governed by the provisions stated in Parker's standard terms and conditions of sale (copy available upon request).

**VRS standard version (Ø32 to 125mm)**

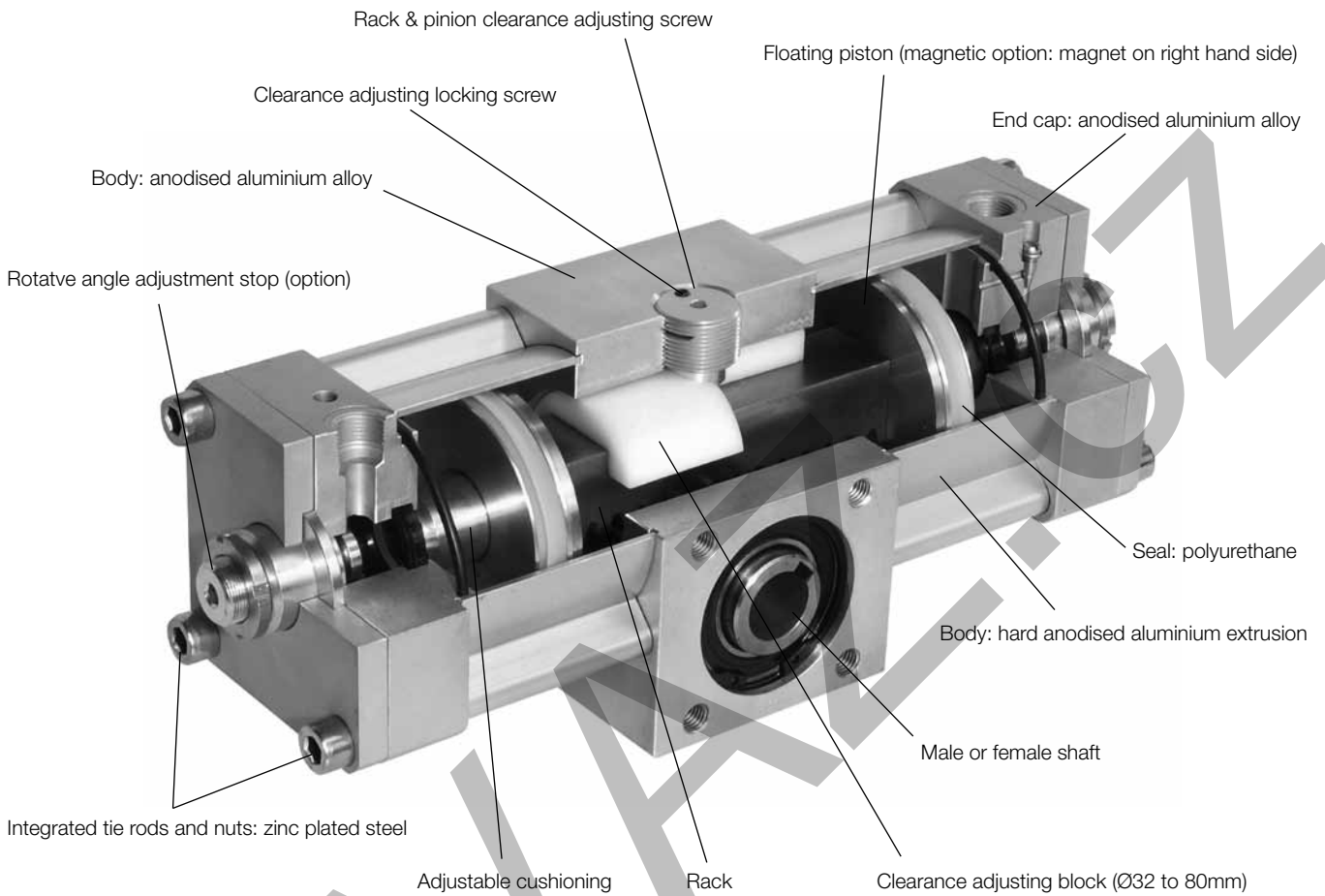

**VRA version (Ø32 to 80mm) for corrosive environment**

- Aluminium blanking plate for the clearance adjustment screw
- Rack and pinion gear contained in waterproof enclosure (silicone seal)
- Stainless steel waterproof ball bearings
- Stainless steel pinion
- Stainless steel circlips, internal tie rods and screws
- Optional Magnetic version



## Material specification

	VRS	VRA
Rack	XC40 steel	XC40 steel
Floating piston	Aluminium	Aluminium
Magnet (**M version)	Magnetic elastomer	Magnetic elastomer
Piston seals	Polyurethane	Polyurethane
Rack and pinion gear seals		Silicone
Body	Anodised aluminium	Anodised aluminium
Integrated tie rods, nuts, circlips, screws	Zinc plated steel	303 stainless steel
Body	Hard anodised aluminium extrusion	Hard anodised aluminium extrusion
End caps	Anodised aluminium	Anodised aluminium
Male or female transmission shaft	XC40 steel	304 stainless steel (female)
Cushion sleeve	Brass	Brass
Clearance adjusting block (Ø 32 to 80mm)	Acetal	Acetal
Adjusting screw blanking plate		Aluminium + silicone seal

## Condition of use

	Ø 32 to 80mm	Ø 100 and 125mm
Temperature range	-10°C to +60°C (14°F to 140°F)	
Pressure range (bar)	0.5 to 10 7 to 145 psi)	0.3 to 10 (4 to 145 psi)
Air condition	Filtered air 40µ, lubricated or non lubricated, dry or non dry	

## Theoretical torque

Ø Bore mm	Pinion Module	ØPm	Torque (N.m)				
			2 bar	4 bar	6 bar	8 bar	10 bar
32	1.5	20	2.4	4.8	7.2	9.6	12
40	2	40	5.0	10.0	15.0	20.0	25
50	2	40	8.0	16.0	24.0	32.0	40
63	3	54	17.0	34.0	51.0	68.0	85
80	3	54	27.0	54.0	81.0	108.0	135
100	5	75	58.0	116.0	174.0	232.0	290
125	5	75	92.0	184.0	276.0	368.0	460

The table above shows the theoretical torque at different pressures. A maximum efficiency of 80% should be assured due to functional losses.

## Technical data

Bore (mm)		32	40	50	63	80	100	125
Maximum load (N)	Axial	110	350	350	1050	1050	2500	2500
	Radial	35	220	220	900	900	2000	2000
Cushion angle (°)		50	45	45	32	32	30	30
Nominal moment of inertia (kg.m <sup>2</sup> )		0.003	0.01	0.02	0.1	0.2	0.3	0.4
Rotative angle (-1°)		96°, 186°, 366°						
Angular tolerance		0°10'	0°10'	0°10'	0°10'	0°10'	1°	1°

**Technical data**

**Rotative angle adjustable stop and cushion angle**

Ø Cylinder bore (mm)	32	40	50	63	80	100	125
	96°	96°	96°	96°	96°	96°	96°
Rotative angle	Ω 186°	186°	186°	186°	186°	186°	186°
	366°	366°	366°	366°	366°	366°	366°
Cushion angle	α 50°	45°	45°	32°	32°	30°	30°
Adjustable angle	β 15°	15°	15°	15°	15°	15°	15°

(R option: Adjustable stop)

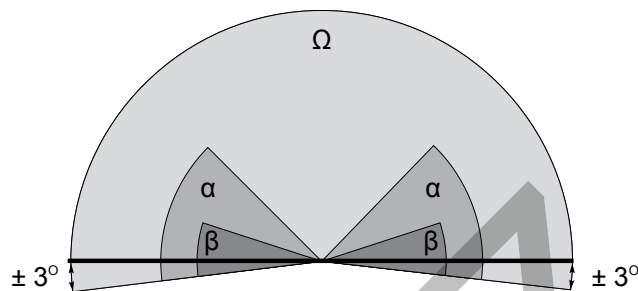

**Maintenance**

After 2 million cycles in nominal moment of inertia conditions, the cylinder should be dismantled and seals replaced. When assembling, grease gear and rack with ESSO GP GREASE or equivalent. Adjust clearance of gear and rack (Ø 32 to 80 cylinder bore) with the screw (1) in order to obtain the following minimum operating pressures (unloaded cylinder), then secure the adjustment with the screw (2).

**Backlash adjustment**

Ø Bore (mm)	Minimum operating pressure
Ø 32 and 40	0.5 bar (7 psi)
Ø 50 and 63	0.4 bar (6 psi)
Ø 80	0.3 bar (4 psi)

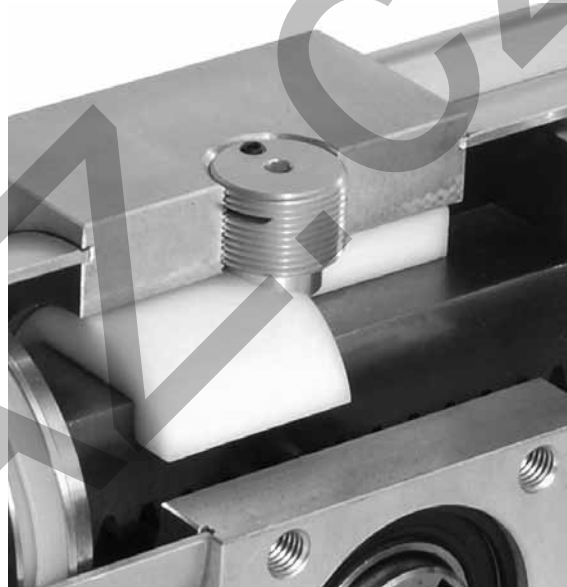

**Weight - kg (lbs)**

Standard cylinder : Female shaft, 0° rotation, magnetic or non magnetic

Bore (mm)	32	40	50	63	80	100	125
Standard cylinder	1.30 (2.9)	2.20 (4.8)	2.50 (5.5)	5.30 (11.7)	6.20 (13.7)	15.70 (34.6)	17.80 (39.2)
For male shaft	0.10 (0.2)	0.20 (0.4)	0.20 (0.4)	0.45 (1.0)	0.45 (1.0)	1.50 (3.3)	1.50 (3.3)
For one adjustable stop	0.15 (0.3)	0.25 (0.5)	0.35 (0.8)	0.35 (0.8)	0.40 (0.9)	1.00 (2.2)	1.00 (2.2)
Per 90° of rotation	0.10 (0.2)	0.30 (0.7)	0.40 (0.9)	0.70 (1.5)	0.80 (1.8)	2.00 (4.4)	2.30 (5.0)

**Example : VRM050-186FRN** Weight = 2.5 + 0.35 x 1 + 0.40 x 2 = 3.65 kg  
 (5.5 + 0.77 x 1 + 0.88 x 2 = 8.04 lbs)



Dimensions (mm)

Cylinder bores Ø 32 to 80mm

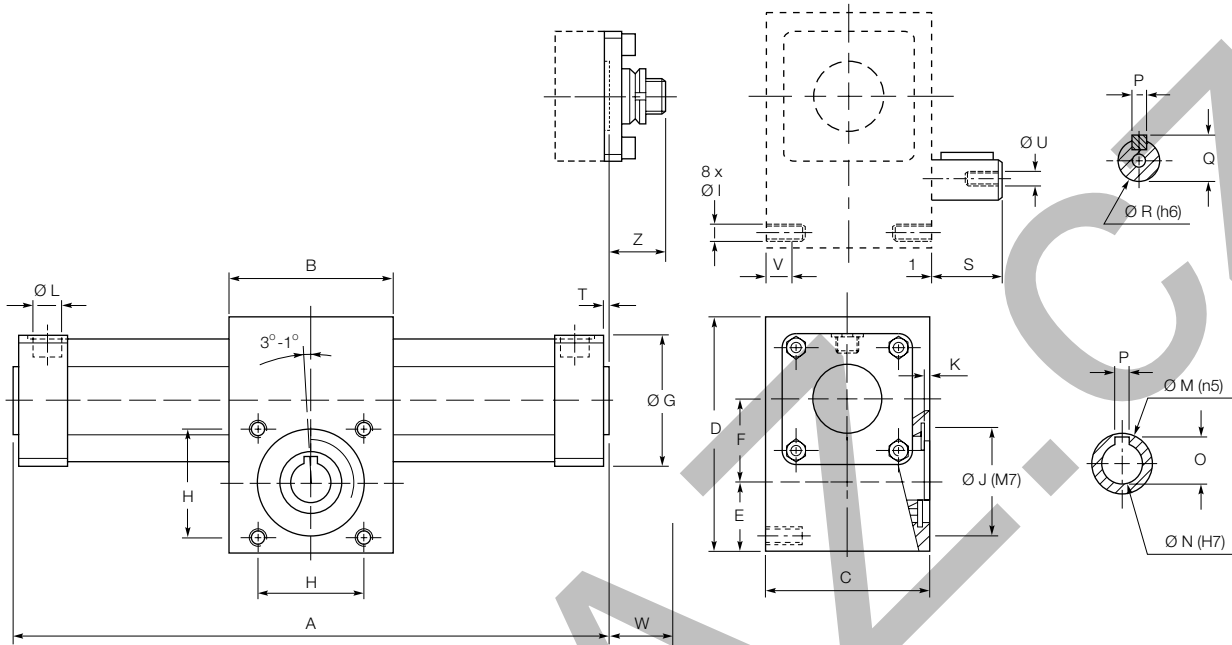

The location of the shaft key is indicated when the pistons are on the left. First rotation as indicated (clockwise).

Ω : Rotative angle 96°, 186° or 360°

Ø	A*	B	C	D	E	F	G	H	I	J	K	L
32	128 + 0.523 Ω	50	50	72	25.0	24.0	45	35	M6	35	2.0	G1/8"
40	163 + 0.6981 Ω	65	65	95	32.5	29.5	52	47	M8	47	3.0	G1/4"
50	163 + 0.6981 Ω	65	65	95	32.5	29.5	65	47	M8	47	3.0	G1/4"
63	209 + 0.9424 Ω	95	95	126	40.0	38.0	75	62	M10	62	3.5	G3/8"
80	209 + 0.9424 Ω	95	95	126	40.0	38.0	95	62	M10	62	3.5	G3/8"
Ø	M	N	O	P	Q	R	S	T	U	V	W*	Z
32	17	10	11.7	4	13.5	12	20	2	M4 x 10	10	22	31
40	25	15	17.2	5	18.0	16	30	3	M5 x 15	12	24	35
50	25	15	17.2	5	18.0	16	30	3	M5 x 15	12	29	35
63	35	24	27.2	8	27.0	24	40	3	M8 x 20	15	32	32
80	35	24	27.2	8	27.0	24	40	3	M8 x 20	15	32	32

\* Add W to A for the magnetic version (magnet on right hand side as standard).

Dimensions (mm)

Cylinder bores  $\varnothing$  100 to 125mm

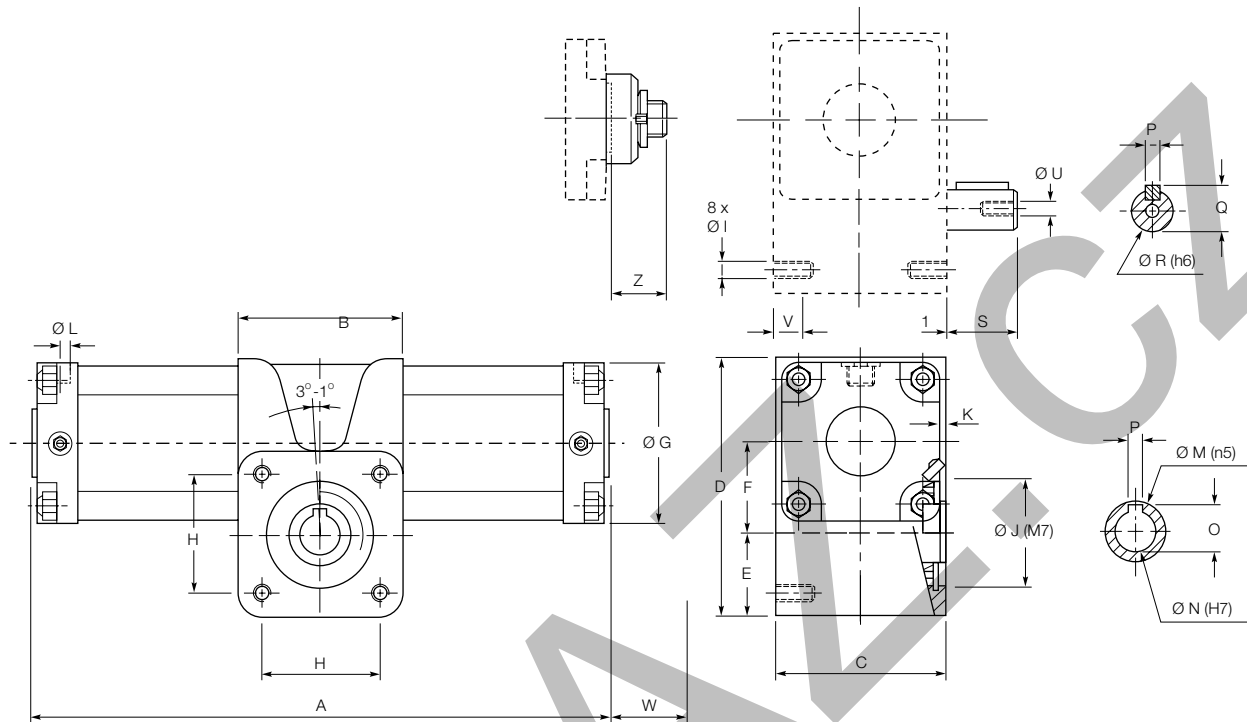

The location of the shaft key is indicated when the pistons are on the left.  
 First rotation as indicated (clockwise).

$\Omega$  : Rotative angle 96°, 186° or 360°

$\varnothing$	A*	B	C	D	E	F	G	H	I	J	K	L
100	304 + 1309 $\Omega$	130	142	188	64.0	53.5	115	90	M14	90	4.5	G1/2"
125	304 + 1309 $\Omega$	130	142	188	64.0	53.5	140	90	M14	90	4.5	G1/2"
$\varnothing$	M	N	O	P	Q	R	S	U	V	W*	Z	
100	55	35	38.7	10	38.5	35	50	M12 x 20	24	4	38	
125	55	35	38.7	10	38.5	35	50	M12 x 20	24	4	38	

\* Add W to A for the magnetic version (magnet on right hand side as standard).

Ordering references

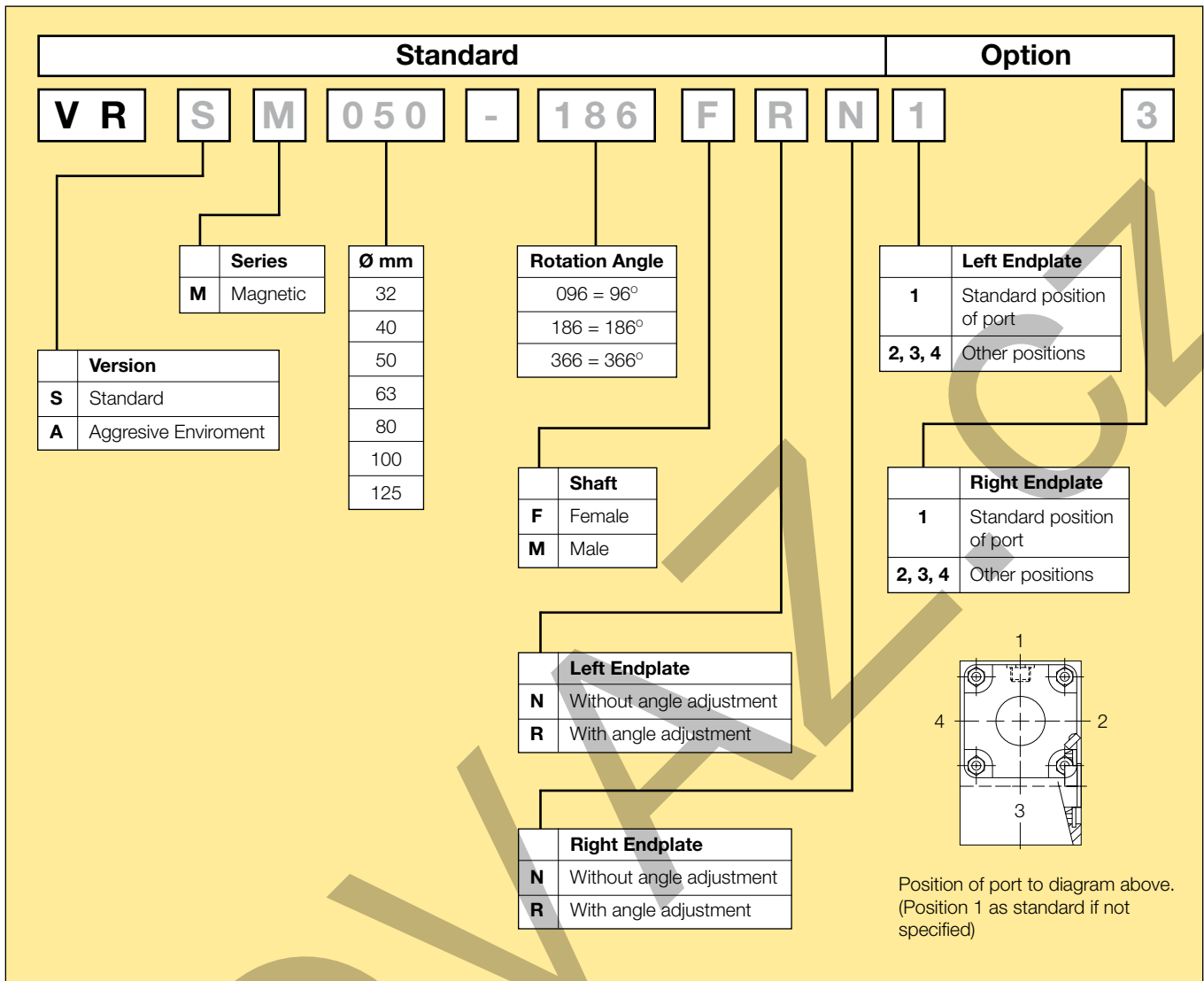

Maintenance - Seal kit

Bore (mm)	32	40	50	63	80	100	125
Actuator VRS / VRSM	<b>JJVR032</b>	<b>JJVR040</b>	<b>JJVR050</b>	<b>JJVR063</b>	<b>JJVR080</b>	<b>JJVR100</b>	<b>JJVR125</b>
Actuator VRA / VRAM	<b>JJVRA032</b>	<b>JJVRA040</b>	<b>JJVRA050</b>	<b>JJVRA063</b>	<b>JJVRA080</b>		



## Sensors

VRSM and VRAM cylinders can be fitted with sensors. These sensors use the following mounting bracket.

Ø Bore (mm)	32	40	50	63	80	100	125
Mounting bracket	P8S-TMA0X*						
<b>A</b>	35	39	48	50	58	70	
<b>B</b>	30	35	42	48	56	65	

**Note:** Mounting brackets and sensors must be ordered separately

\* Please consult Technical Department for 125mm bore.

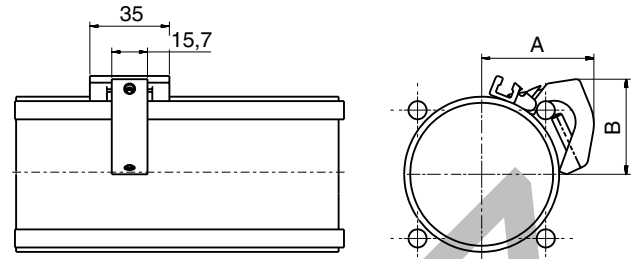

## Electronic sensors

The new electronic sensors are "Solid State", i.e. they have no moving parts at all. They are provided with short-circuit protection and transient protection as standard. The built-in electronics make the sensors suitable for applications with high on and off switching frequency, and where very long service life is required.

### Technical data

Design	GMR (Giant Magnetic Resistance) magneto-resistive function
Installation	From side, down into the sensor groove, so-called drop-in
Outputs	PNP, normally open (also available in NPN design, normally closed, on request)
Voltage range	10-30 VDC 10-18 V DC, ATEX sensor
Ripple	max 10%
Voltage drop	max 2,5 V
Load current	max 100 mA
Internal consumption	max 10 mA
Actuating distance	min 9 mm
Hysteresis	max 1,5 mm
Repeatability accuracy	max 0,2 mm
On/off switching frequency	max 5 kHz
On switching time	max 2 ms
Off switching time	max 2 ms
Encapsulation	IP 67 (EN 60529)
Temperature range	-25 °C to +75 °C -20 °C to +45 °C, ATEX sensor
Indication	LED, yellow
Material housing	PA 12
Material screw	Stainless steel
Cable	PVC or PUR 3x0.25 mm <sup>2</sup> see order code respectively

## Reed sensors

The sensors are based on proven reed switches, which offer reliable function in many applications. Simple installation, a protected position on the cylinder and clear LED indication are important advantages of this range of sensors.

### Technical data

Design	Reed element
Mounting	From side, down into the sensor groove, so-called drop-in
Output	Normally open, or normally closed
Voltage range	10-30 V AC/DC or 10-120 V AC/DC 24-230 V AC/DC
Load current	max 500 mA for 10-30 V or max 100 mA for 10-120 V max 30 mA for 24-230 V
Breaking power (resistive)	max 6 W/VA
Actuating distance	min 9 mm
Hysteresis	max 1,5 mm
Repeatability accuracy	0,2 mm
On/off switching frequency	max 400 Hz
On switching time	max 1,5 ms
Off switching time	max 0,5 ms
Encapsulation	IP 67 (EN 60529)
Temperature range	-25 °C to +75 °C
Indication	LED, yellow
Material housing	PA12
Material screw	Stainless steel
Cable	PVC or PUR 3x0.14 mm <sup>2</sup> see order code respectively

Electronic sensors

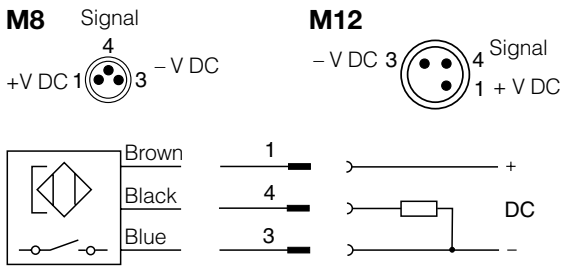

Reed sensors

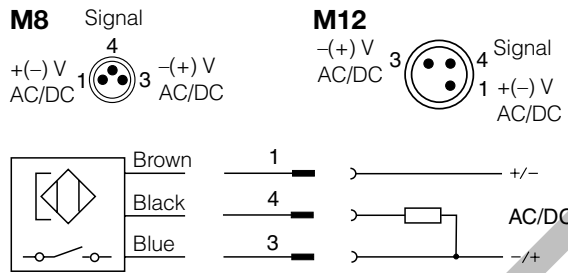

P8S-GCFPX

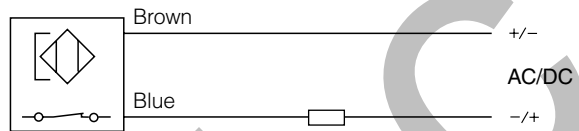

P8S-GRFLX / P8S-GRFLX2

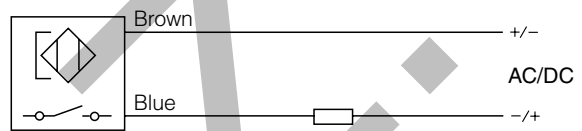

Dimensions

Sensors

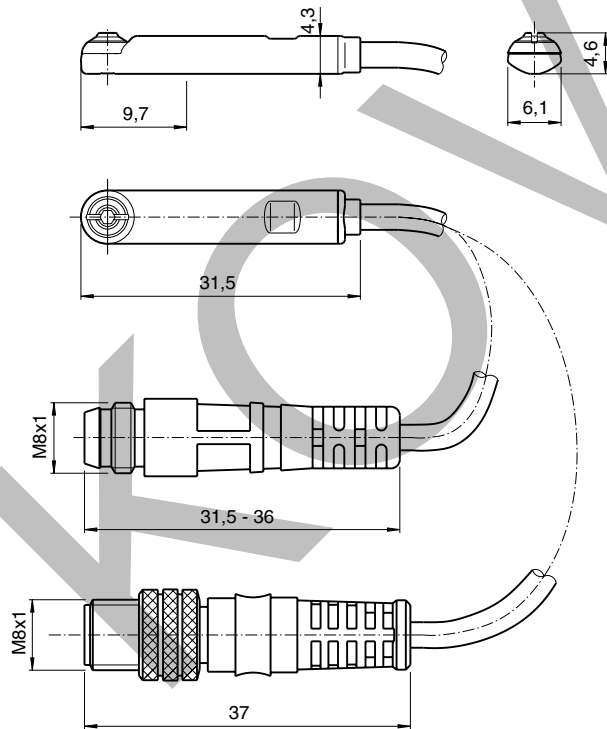

## Ordering data

Output/function	Cable/connector	Weight kg	Order code
<b>Electronic sensors , 10-30 V DC</b>			
PNP type, normally open	0,27 m PUR-cable and 8 mm snap-in male connector	0,007	<b>P8S-GPSHX</b>
PNP type, normally open	1,0 m PUR-cable and 8 mm snap-in male connector	0,013	<b>P8S-GPSCX</b>
PNP type, normally open	1,0 m PUR-cable and M8 screw male connector	0,013	<b>P8S-GPCCX</b>
PNP type, normally open	0,27 m PUR-cable and M12 screw male connector	0,015	<b>P8S-GPMHX</b>
PNP type, normally open	3 m PVC-cable without connector	0,030	<b>P8S-GPFLX</b>
PNP type, normally open	10 m PVC-cable without connector	0,110	<b>P8S-GPFTX</b>
<b>Electronic sensor 18-30 V DC</b>			
<b>ATEX-certified</b>			
			
Type PNP , normally open	3 m PVC-cable without connector	0,030	<b>P8S-GPFLX/EX</b>
<b>Reed sensors , 10-30 V AC/DC</b>			
Normally open	0,27 m PUR-cable and 8 mm snap-in male connector	0,007	<b>P8S-GSSHX</b>
Normally open	1,0 m PUR-cable and 8 mm snap-in male connector	0,013	<b>P8S-GSSCX</b>
Normally open	1,0 m PUR-cable and M8 male connector	0,013	<b>P8S-GSCCX</b>
Normally open	0,27 m PUR-cable and M12 screw male connector	0,015	<b>P8S-GSMHX</b>
Normally open	1,0 m PUR-cable and M12 screw male connector	0,023	<b>P8S-GSMCX</b>
Normally open	3 m PVC-cable without connector	0,030	<b>P8S-GSFLX</b>
Normally open	10 m PVC-cable without connector	0,110	<b>P8S-GSFTX</b>
Normally closed	5m PVC-cable without connector <sup>1)</sup>	0,050	<b>P8S-GCFPX</b>
<b>Reed sensors, 10-120 V AC/DC</b>			
Normally open	3 m PVC-cable without connector	0,030	<b>P8S-GRFLX</b>
<b>Reed sensorer, 24-230 V AC/DC</b>			
Normally open	3 m PVC-cable without connector	0,030	<b>P8S-GRFLX2</b>

1) Without LED

**Adapter for tie-rod design**

Description	Weight kg	Order code
Double jointed adapter for bore Ø 32 to 125 mm	0,07	<b>P8S-TMA0X</b>



### Connecting cables with one connector

The cables have an integral snap-in female connector.



Type of cable	Cable/connector	Weight kg	Order code
<b>Cables for sensors, complete with one female connector</b>			
Cable, Flex PVC	3 m, 8 mm Snap-in connector	0,07	9126344341
Cable, Flex PVC	10 m, 8 mm Snap-in connector	0,21	9126344342
Cable, Super Flex PVC	3 m, 8 mm Snap-in connector	0,07	9126344343
Cable, Super Flex PVC	10 m, 8 mm Snap-in connector	0,21	9126344344
Cable, Polyurethane	3 m, 8 mm Snap-in connector	0,01	9126344345
Cable, Polyurethane	10 m, 8 mm Snap-in connector	0,20	9126344346
Cable, Polyurethane	5 m, M12 screw connector	0,07	9126344348
Cable, Polyurethane	10 m, M12 screw connector	0,20	9126344349

### Male connectors for connecting cables

Cable connectors for producing your own connecting cables. The connectors can be quickly attached to the cable without special tools. Only the outer sheath of the cable is removed. The connectors are available for M8 and M12 screw connectors and meet protection class IP 65.



Connector	Weight kg	Order code
M8 screw connector	0,017	P8CS0803J
M12 screw connector	0,022	P8CS1204J

### Ready to use connecting cables with connectors at each end

As accessories the system comprises a large number of different cables in order to meet all requirements that may arise and to make the installation simple, fast and reliable. Cables with moulded 8 mm snap-in round contacts in both ends. The cables are available in two types, one with a straight male and female connectors respectively, and one with a straight 3-pole male connector in one end and an angled 3-pole female connector in the other end.



#### Technical data

##### Contacts

Moulded 8 mm snap-in male/female contacts.  
Enclosure IP67

##### Cable

Conductor 3x0,25 mm<sup>2</sup> (32x0,10 mm<sup>2</sup>)  
Sheath PVC/PUR  
Colour Black

Cables with straight 3-pole male and female connectors respectively.

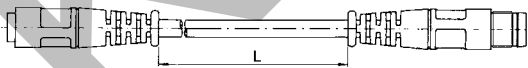

Cables with a straight 3-pole male connector in one end and an angled 3-pole female connector in the other end.



Designation	Weight kg	Order code
Cable with straight contacts, 0,2 m	0,02	9121717014
Cable with straight contacts, 0,3 m	0,02	9121717015
Cable with straight contacts, 0,5 m	0,03	9121717016
Cable with straight contacts, 1,0 m	0,03	9121717017
Cable with straight contacts, 2,0 m	0,05	9121717018
Cable with straight contacts, 3,0 m	0,07	9121717019
Cable with straight contacts, 5,0 m	0,12	9121717020
Cable with straight contacts, 10 m	0,23	9121717021

Designation	Weight kg	Order code
Cable with straight and angled connectors, 0,2 m	0,02	9121717022
Cable with straight and angled connectors, 0,3 m	0,02	9121717023
Cable with straight and angled connectors, 0,5 m	0,03	9121717024
Cable with straight and angled connectors, 1,0 m	0,03	9121717025
Cable with straight and angled connectors, 2,0 m	0,05	9121717026
Cable with straight and angled connectors, 3,0 m	0,07	9121717027
Cable with straight and angled connectors, 5,0 m	0,12	9121717028
Cable with straight and angled connectors, 10 m	0,23	9121717029

### Connection block Valvetronic 110

The Valvetronic 110 is a connection block that can be used for collecting signals from sensors at various points on a machine and connecting them to the control system via a multicore cable. Valvetronic 110 can also be used for central connection of the multi-core cable to the outputs of a control system, and can be laid to a machine where the output signals can be connected. The connection block has ten 8 mm snap-in circular connectors and a multi-core cable which is available in lengths of 3 or 10 m. The connections on the block are numbered from 1 to 10. Blanking plugs are available for unused connections, as labels for marking the connections of each block.



### Technical data

#### Connections:

Ten 3-pole numbered 8 mm round snap-in female contacts

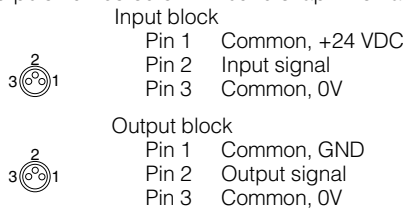

#### Electrical data:

Voltage: 24 VDC (max. 60 V AC/75 V DC) according to DIN 0110 class C  
 Insulation group: max. 1 A per connection  
 Load: total max. 3 A

#### Cable:

Length: 3 m or 10 m  
 Type of cable: LifYY11Y  
 Conductor: 12  
 Area: 0.34 mm<sup>2</sup>  
 Colour marking: According to DIN 47 100

#### Mechanical data

Enclosure: IP 67, DIN 40050 with fitted contacts and/or blanking plugs.  
 Temperature: -20 °C to +70 °C



#### Material

Body: PA 6,6 VD according to UL 94  
 Contact holder: PBTP  
 Snap-in ring: LDPE  
 Moulding mass: Epoxy  
 Seal: NBR  
 Screws: Plated steel

#### Industrial durability

Good chemical and oil resistance. Tests should be performed in aggressive environments.

### Ordering data

Designation	Weight kg	Order code
 Connection block Valvetronic 110 with 3 m cable Connection block Valvetronic 110 with 10 m cable	0,32 0,95	9121719001 9121719002
 Blanking plugs (pack of 10) Use blanking plugs to close unused connections.	0,02	9121719003
 Labels (pack of 10) White labels to insert in grooves on the side of the connection	0,02	9121719004

### Dimensions and wiring diagrams

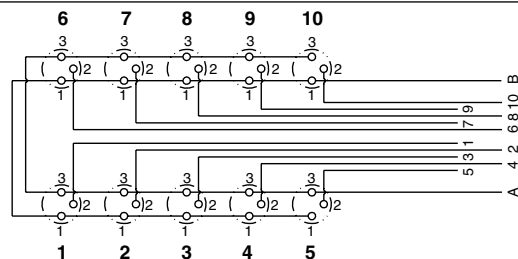
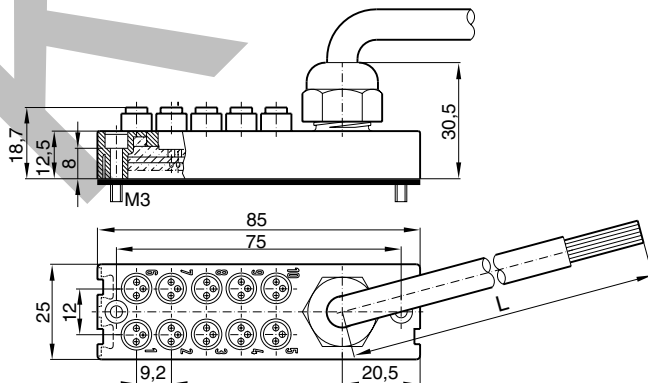

Conductor	Colour	Input	Output
1	Pink	Signal 1	Signal 1
2	Grey	Signal 2	Signal 2
3	Yellow	Signal 3	Signal 3
4	Green	Signal 4	Signal 4
5	White	Signal 5	Signal 5
6	Red	Signal 6	Signal 6
7	Black	Signal 7	Signal 7
8	Violet	Signal 8	Signal 8
9	Grey-Pink	Signal 9	Signal 9
10	Red-Blue	Signal 10	Signal 10
A	Blue	0 V	0 V
B	Brown	+24 V	PE

KOLVANZ.CZ

KOLVANZ.CZ



# Parker Worldwide

## Europe, Middle East, Africa

**AE – United Arab Emirates,** Dubai

Tel: +971 4 8127100  
parker.me@parker.com

**AT – Austria,** Wiener Neustadt

Tel: +43 (0)2622 23501-0  
parker.austria@parker.com

**AT – Eastern Europe,** Wiener Neustadt

Tel: +43 (0)2622 23501 900  
parker.easteurope@parker.com

**AZ – Azerbaijan,** Baku

Tel: +994 50 2233 458  
parker.azerbaijan@parker.com

**BE/LU – Belgium,** Nivelles

Tel: +32 (0)67 280 900  
parker.belgium@parker.com

**BY – Belarus,** Minsk

Tel: +375 17 209 9399  
parker.belarus@parker.com

**CH – Switzerland,** Etoy

Tel: +41 (0)21 821 87 00  
parker.switzerland@parker.com

**CZ – Czech Republic,** Klecany

Tel: +420 284 083 111  
parker.czechrepublic@parker.com

**DE – Germany,** Kaarst

Tel: +49 (0)2131 4016 0  
parker.germany@parker.com

**DK – Denmark,** Ballerup

Tel: +45 43 56 04 00  
parker.denmark@parker.com

**ES – Spain,** Madrid

Tel: +34 902 330 001  
parker.spain@parker.com

**FI – Finland,** Vantaa

Tel: +358 (0)20 753 2500  
parker.finland@parker.com

**FR – France,** Contamine s/Arve

Tel: +33 (0)4 50 25 80 25  
parker.france@parker.com

**GR – Greece,** Athens

Tel: +30 210 933 6450  
parker.greece@parker.com

**HU – Hungary,** Budapest

Tel: +36 1 220 4155  
parker.hungary@parker.com

**IE – Ireland,** Dublin

Tel: +353 (0)1 466 6370  
parker.ireland@parker.com

**IT – Italy,** Corsico (MI)

Tel: +39 02 45 19 21  
parker.italy@parker.com

**KZ – Kazakhstan,** Almaty

Tel: +7 7272 505 800  
parker.easteurope@parker.com

**NL – The Netherlands,** Oldenzaal

Tel: +31 (0)541 585 000  
parker.nl@parker.com

**NO – Norway,** Asker

Tel: +47 66 75 34 00  
parker.norway@parker.com

**PL – Poland,** Warsaw

Tel: +48 (0)22 573 24 00  
parker.poland@parker.com

**PT – Portugal,** Leca da Palmeira

Tel: +351 22 999 7360  
parker.portugal@parker.com

**RO – Romania,** Bucharest

Tel: +40 21 252 1382  
parker.romania@parker.com

**RU – Russia,** Moscow

Tel: +7 495 645-2156  
parker.russia@parker.com

**SE – Sweden,** Spånga

Tel: +46 (0)8 59 79 50 00  
parker.sweden@parker.com

**SK – Slovakia,** Banská Bystrica

Tel: +421 484 162 252  
parker.slovakia@parker.com

**SL – Slovenia,** Novo Mesto

Tel: +386 7 337 6650  
parker.slovenia@parker.com

**TR – Turkey,** Istanbul

Tel: +90 216 4997081  
parker.turkey@parker.com

**UA – Ukraine,** Kiev

Tel: +380 44 494 2731  
parker.ukraine@parker.com

**UK – United Kingdom,** Warwick

Tel: +44 (0)1926 317 878  
parker.uk@parker.com

**ZA – South Africa,** Kempton Park

Tel: +27 (0)11 961 0700  
parker.southafrica@parker.com

## North America

**CA – Canada,** Milton, Ontario

Tel: +1 905 693 3000

**US – USA,** Cleveland

Tel: +1 216 896 3000

## Asia Pacific

**AU – Australia,** Castle Hill

Tel: +61 (0)2-9634 7777

**CN – China,** Shanghai

Tel: +86 21 2899 5000

**HK – Hong Kong**

Tel: +852 2428 8008

**IN – India,** Mumbai

Tel: +91 22 6513 7081-85

**JP – Japan,** Tokyo

Tel: +81 (0)3 6408 3901

**KR – South Korea,** Seoul

Tel: +82 2 559 0400

**MY – Malaysia,** Shah Alam

Tel: +60 3 7849 0800

**NZ – New Zealand,** Mt Wellington

Tel: +64 9 574 1744

**SG – Singapore**

Tel: +65 6887 6300

**TH – Thailand,** Bangkok

Tel: +662 186 7000-99

**TW – Taiwan,** Taipei

Tel: +886 2 2298 8987

## South America

**AR – Argentina,** Buenos Aires

Tel: +54 3327 44 4129

**BR – Brazil,** Sao Jose dos Campos

Tel: +55 800 727 5374

**CL – Chile,** Santiago

Tel: +56 2 623 1216

**MX – Mexico,** Apodaca

Tel: +52 81 8156 6000

European Product Information Centre

Free phone: 00 800 27 27 5374

(from AT, BE, CH, CZ, DE, DK, EE, ES, FI, FR, IE, IL, IS, IT, LU, MT, NL, NO, PL, PT, RU, SE, SK, UK, ZA)

### Parker Hannifin Ltd.

Tachbrook Park Drive  
Tachbrook Park,  
Warwick, CV34 6TU  
United Kingdom  
Tel.: +44 (0) 1926 317 878  
Fax: +44 (0) 1926 317 855  
parker.uk@parker.com  
www.parker.com