

Rychlospojky KAMLOK



Normy výrobků:

MIL A-A-59326A

EN 14420-7

DIN 2828

Velikosti:

DN15 až DN300

Materiály:

Nerezová ocel 316 (Přesné odlévání)

Mosaz (Kování)

Hliník (Odlévání)

Polypropylen (Vstřikování)

Typ závitů:

BSPP: EN ISO228-1 / DIN ISO 228-1

BSPT: EN 10226-1 / DIN 2999-1

NPT: ANSI B 1.20.1

Pracovní tlak:

18 bar / 250 psi (pro SS a MS)

18 bar / 250 psi (pro AL)

6 bar / 87 psi (pro PP)

Těsnění spojky:

NBR (-30°C/+120°C)

EPDM (-45°C/+145°C)

FPM (-30°C/+200°C)

CSM (-30°C/+125°C)

Těsnění závitů:

PU (-50°C/+100°C)

PTFE (-25°C/+250°C)

Použití:

Chemikálie

Všechna průmyslová odvětví

Vybavení cisteren

	SS		MS		AL		PP	
	Bar	Psi	Bar	Psi	Bar	Psi	Bar	Psi
DN15	16	225	16	225	16	225	6	87
DN20	18	250	18	250	16	225	6	87
DN25	18	250	18	250	18	250	6	87
DN32	18	250	18	250	18	250	6	87
DN40	18	250	18	250	18	250	6	87
DN50	18	250	18	250	18	250	6	87
DN65	16	225	16	225	16	225	6	87
DN80	14	220	9	150	9	125	6	87
DN100	7	100	7	100	7	100	6	87
DN125	7	100	5	75	5	75	3	50
DN150	7	100	5	75	5	75	3	50
DN200	5	75	5	75	5	75	3	50



Systém rychlospojek Kamlok je určen k všeobecnému použití v průmyslu, zemědělství a cisternové dopravě. Utažení funguje na principu dvou vaček, které se zaklíní do protikusu a tím zajišťují výbornou pevnost spoje. Rychlospojky pracují v rozsahu tlaků 3 bar až 18 bar pracovního tlaku v rozsahu pracovních teplot

-20 °C až +65 °C.

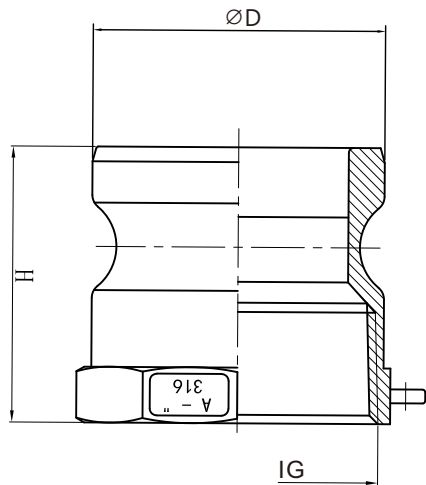

Typ A

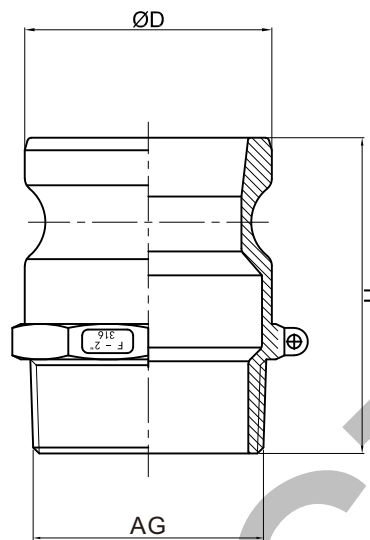

Typ F

Název (A)	Závit	D(mm)	H(mm)
050	G1/2"	24.3	33.4
075	G3/4"	32.1	35.4
100	G1"	36.7	43.5
125	G1 1/4"	45.5	50.5
150	G1 1/2"	53.4	52
200	G2"	63	59.5
250	G2 1/2"	75.8	75
300	G3"	91.5	65
400	G4"	119.5	70
500	G5"	145.6	80
600	G6"	176	83

Název (F)	Závit	D(mm)	H(mm)
050	R2999-1/2"	24.3	46.4
075	R2999-3/4"	32.1	48.4
100	R2999-1"	36.7	57
125	R2999-1 1/4"	45.5	67.5
150	R2999-1 1/2"	53.4	69
200	R2999-2"	63	80.5
250	R2999-2 1/2"	75.8	86
300	R2999-3"	91.5	94
400	R2999-4"	119.5	101
500	R2999-5"	145.6	114
600	R2999-6"	176	122

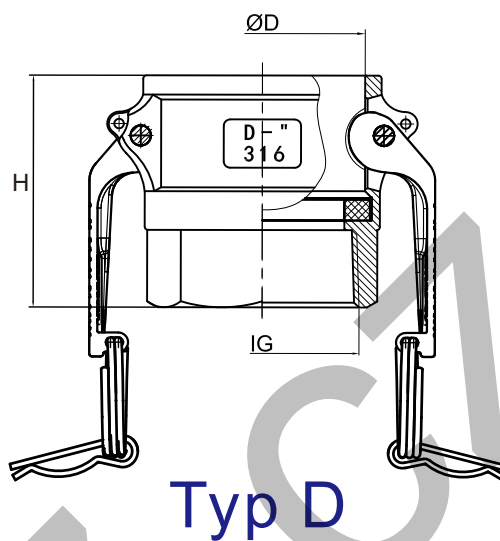
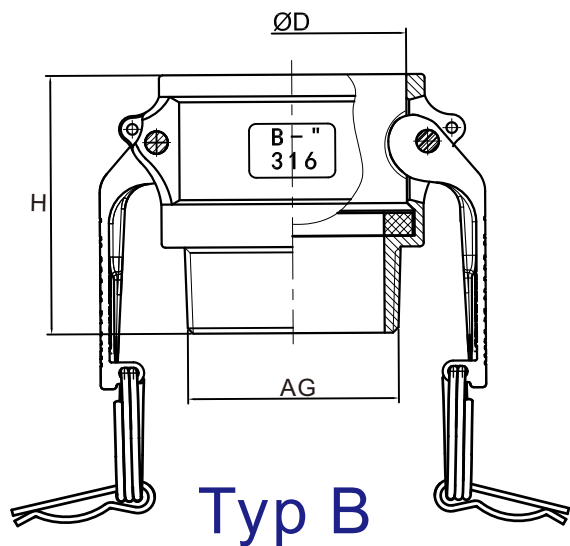

Název (B)	Závit	D(mm)	H(mm)
050	R2999-1/2"	24.8	43.5
075	R2999-3/4"	32.5	45
100	R2999-1"	37.3	54
125	R2999-1 1/4"	46	60.5
150	R2999-1 1/2"	54	62.5
200	R2999-2"	63.8	72
250	R2999-2 1/2"	76	75
300	R2999-3"	92.5	82
400	R2999-4"	120.3	86.5
500	R2999-5"	146.5	95.5
600	R2999-6"	176.5	107

Název (D)	Závit	D (mm)	H (mm)
050	G1/2"	24.8	43.5
075	G3/4"	32.5	45
100	G1"	37.3	54
125	G1 1/4"	46	60.5
150	G1 1/2"	54	62.5
200	G2"	63.8	72
250	G2 1/2"	76	75
300	G3"	92.5	82
400	G4"	120.3	86.5
500	G5"	146.5	95.5
600	G6"	176.5	104

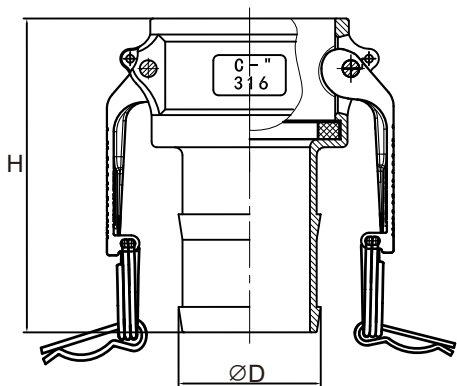

Typ C

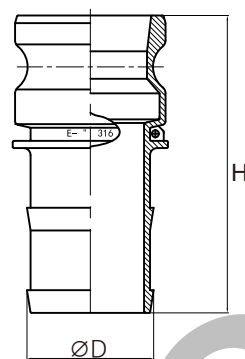

Typ E

Název (C)	Velikost	D (mm)	H (mm)
050	1/2"	15	61
075	3/4"	21	78
100	1"	27.3	92.5
125	1 1/4"	34	96.5
150	1 1/2"	40.6	102
200	2"	53	117
250	2 1/2"	66.7	126
300	3"	78.8	146
400	4"	104.5	150.5
500	5"	130	172.5
600	6"	155.5	227

Název (E)	Velikost	D(mm)	H(mm)
050	1/2"	15	66.5
075	3/4"	21	80
100	1"	27.3	97.5
125	1 1/4"	34	102.5
150	1 1/2"	40.6	109
200	2"	53	124.5
250	2 1/2"	66.7	136.5
300	3"	78.8	154.5
400	4"	104.5	162
500	5"	130	180
600	6"	155.5	239

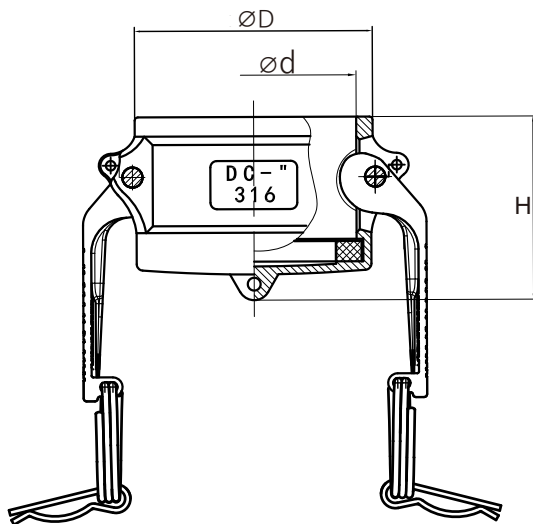

Typ DC

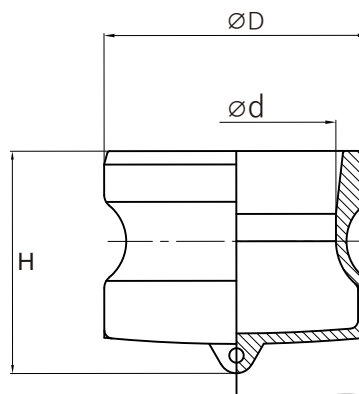

Typ DP

Název (DC)	Velikost	D (mm)	d (mm)	H (mm)
050	1/2"	33	24.8	35
075	3/4"	40	32.5	38.5
100	1"	46	37.3	44.5
125	1 1/4"	56	46	49.5
150	1 1/2"	64	54	52
200	2"	74	63.8	57
250	2 1/2"	87	76.5	59.5
300	3"	105	92.5	65
400	4"	134	120.3	66
500	5"	161	146.5	74
600	6"	194	176.5	80

Název (DP)	Velikost	D (mm)	d (mm)	H (mm)
050	1/2"	24.3	14	30.9
075	3/4"	32.1	19	32
100	1"	36.7	24	40.5
125	1 1/4"	45.5	30.3	46
150	1 1/2"	53.4	38.5	48
200	2"	63	48	44.5
250	2 1/2"	75.8	59.6	58.5
300	3"	91.5	76	62
400	4"	119.5	100	65.5
500	5"	145.6	126	67.5
600	6"	176	152	80.5

Vsuvka KAMLOK typ A - samec s vnitřním závitem

Název	Závít	Kód	Hmotnost(kg)	Těsnění	Materiál
050	ISO228-½"	050A.SS	0.07	PTFE	SS
075	ISO228-¾"	075A.SS	0.11	PTFE	SS
100	ISO228-1"	100A.SS	0.15	PTFE	SS
125	ISO228-1¼"	125A.SS	0.24	PTFE	SS
150	ISO228-1½"	150A.SS	0.32	PTFE	SS
200	ISO228-2"	200A.SS	0.42	PTFE	SS
250	ISO228-2½"	250A.SS	0.71	PTFE	SS
300	ISO228-3"	300A.SS	0.73	PTFE	SS
400	ISO228-4"	400A.SS	1.42	PTFE	SS
500	ISO228-5"	500A.SS	1.92	PTFE	SS
600	ISO228-6"	600A.SS	3.17	PTFE	SS
800	ISO228-8"	800A.SS	2.31	PTFE	SS
1000	ISO228-10"	-	-	PTFE	SS
1200	ISO228-12"	-	-	PTFE	SS



050	ISO228-½"	050A.AL	0.02	NBR	AL
075	ISO228-¾"	075A.AL	0.04	NBR	AL
100	ISO228-1"	100A.AL	0.05	NBR	AL
125	ISO228-1¼"	125A.AL	0.09	NBR	AL
150	ISO228-1½"	150A.AL	0.11	NBR	AL
200	ISO228-2"	200A.AL	0.15	NBR	AL
250	ISO228-2½"	250A.AL	0.24	NBR	AL
300	ISO228-3"	300A.AL	0.27	NBR	AL
400	ISO228-4"	400A.AL	0.58	NBR	AL
500	ISO228-5"	500A.AL	0.90	NBR	AL
600	ISO228-6"	600A.AL	0.84	NBR	AL
800	ISO228-8"	800A.AL	2.31	NBR	AL
1000	ISO228-10"	-	-	NBR	AL
1200	ISO228-12"	-	-	NBR	AL



050	ISO228-½"	050A.MS	0.07	NBR	MS
075	ISO228-¾"	075A.MS	0.10	NBR	MS
100	ISO228-1"	100A.MS	0.15	NBR	MS
125	ISO228-1¼"	125A.MS	0.20	NBR	MS
150	ISO228-1½"	150A.MS	0.29	NBR	MS
200	ISO228-2"	200A.MS	0.35	NBR	MS
250	ISO228-2½"	250A.MS	0.72	NBR	MS
300	ISO228-3"	300A.MS	0.73	NBR	MS
400	ISO228-4"	400A.MS	1.48	NBR	MS
500	ISO228-5"	500A.MS	1.79	NBR	MS
600	ISO228-6"	600A.MS	3.38	NBR	MS
800	ISO228-8"	-	7.36	NBR	MS
1000	ISO228-10"	-	-	NBR	MS
1200	ISO228-12"	-	-	NBR	MS



050	ISO228-½"	050A.PP	0.01	NBR	PP
075	ISO228-¾"	075A.PP	0.02	NBR	PP
100	ISO228-1"	100A.PP	0.03	NBR	PP
125	ISO228-1¼"	125A.PP	0.05	NBR	PP
150	ISO228-1½"	150A.PP	0.06	NBR	PP
200	ISO228-2"	200A.PP	0.09	NBR	PP
250	ISO228-2½"	250A.PP	0.14	NBR	PP
300	ISO228-3"	300A.PP	0.18	NBR	PP
400	ISO228-4"	400A.PP	0.36	NBR	PP
500	ISO228-5"	500A.PP	-	NBR	PP
600	ISO228-6"	600A.PP	-	NBR	PP



KAMLOK typu A je možné dodat i se závitem NPT nebo BSP

Rychlospojka KAMLOK typ B - samice s vnějším závitem

Název	Závit	Kód	Hmotnost(kg)	Těsnění	Materiál
050	R2999-1/2"	050B.SS	0.12	NBR	SS
075	R2999-3/4"	075B.SS	0.20	NBR	SS
100	R2999-1"	100B.SS	0.29	NBR	SS
125	R2999-1 1/4"	125B.SS	0.47	NBR	SS
150	R2999-1 1/2"	150B.SS	0.54	NBR	SS
200	R2999-2"	200B.SS	0.67	NBR	SS
250	R2999-2 1/2"	250B.SS	1.14	NBR	SS
300	R2999-3"	300B.SS	1.36	NBR	SS
400	R2999-4"	400B.SS	1.97	NBR	SS
500	R2999-5"	500B.SS	2.98	NBR	SS
600	R2999-6"	600B.SS	4.11	NBR	SS
800	R2999-8"	-	2.60	NBR	SS
1000	R2999-10"	-	-	NBR	SS
1200	R2999-12"	-	-	NBR	SS
050	R2999-1/2"	050B.AL	0.07	NBR	AL
075	R2999-3/4"	075B.AL	0.10	NBR	AL
100	R2999-1"	100B.AL	0.16	NBR	AL
125	R2999-1 1/4"	125B.AL	0.27	NBR	AL
150	R2999-1 1/2"	150B.AL	0.30	NBR	AL
200	R2999-2"	200B.AL	0.35	NBR	AL
250	R2999-2 1/2"	250B.AL	0.43	NBR	AL
300	R2999-3"	300B.AL	0.68	NBR	AL
400	R2999-4"	400B.AL	0.92	NBR	AL
500	R2999-5"	500B.AL	1.81	NBR	AL
600	R2999-6"	600B.AL	1.78	NBR	AL
800	R2999-8"	800B.AL	2.31	NBR	AL
1000	R2999-10"	-	-	NBR	AL
1200	R2999-12"	-	-	NBR	AL
050	R2999-1/2"	050B.MS	0.17	NBR	MS
075	R2999-3/4"	075B.MS	0.21	NBR	MS
100	R2999-1"	100B.MS	0.32	NBR	MS
125	R2999-1 1/4"	125B.MS	0.45	NBR	MS
150	R2999-1 1/2"	150B.MS	0.52	NBR	MS
200	R2999-2"	200B.MS	0.64	NBR	MS
250	R2999-2 1/2"	250B.MS	0.94	NBR	MS
300	R2999-3"	300B.MS	1.38	NBR	MS
400	R2999-4"	400B.MS	1.94	NBR	MS
500	R2999-5"	500B.MS	3.98	NBR	MS
600	R2999-6"	600B.MS	3.65	NBR	MS
800	R2999-8"	-	-	NBR	MS
1000	R2999-10"	-	-	NBR	MS
1200	R2999-12"	-	-	NBR	MS
050	R2999-1/2"	050B.PP	0.07	NBR	PP
075	R2999-3/4"	075B.PP	0.08	NBR	PP
100	R2999-1"	100B.PP	0.11	NBR	PP
125	R2999-1 1/4"	125B.PP	0.21	NBR	PP
150	R2999-1 1/2"	150B.PP	0.21	NBR	PP
200	R2999-2"	200B.PP	0.25	NBR	PP
250	R2999-2 1/2"	250B.PP	0.30	NBR	PP
300	R2999-3"	300B.PP	0.50	NBR	PP
400	R2999-4"	400B.PP	0.76	NBR	PP



KAMLOK typu B je možné dodat i se závitem NPT

Rychlospojka KAMLOK typ C - samice s nátrubkem na hadici

Název	Velikost	Kód	Hmotnost(kg)	Těsnění	Materiál
050	1/2"	050C.SS	0.12	NBR	SS
075	3/4"	075C.SS	0.20	NBR	SS
100	1"	100C.SS	0.29	NBR	SS
125	1 1/4"	125C.SS	0.47	NBR	SS
150	1 1/2"	150C.SS	0.54	NBR	SS
200	2"	200C.SS	0.67	NBR	SS
250	2 1/2"	250C.SS	1.14	NBR	SS
300	3"	300C.SS	1.35	NBR	SS
400	4"	400C.SS	1.97	NBR	SS
500	5"	500C.SS	2.98	NBR	SS
600	6"	600C.SS	4.11	NBR	SS
800	8"	-	2.60	NBR	SS
1000	10"	-	-	NBR	SS
1200	12"	-	-	NBR	SS
050	1/2"	050C.AL	0.07	NBR	AL
075	3/4"	075C.AL	0.10	NBR	AL
100	1"	100C.AL	0.16	NBR	AL
125	1 1/4"	125C.AL	0.27	NBR	AL
150	1 1/2"	150C.AL	0.30	NBR	AL
200	2"	200C.AL	0.35	NBR	AL
250	2 1/2"	250C.AL	0.43	NBR	AL
300	3"	300C.AL	0.68	NBR	AL
400	4"	400C.AL	0.92	NBR	AL
500	5"	500C.AL	1.81	NBR	AL
600	6"	600C.AL	1.78	NBR	AL
800	8"	800C.AL	4.75	NBR	AL
1000	10"	-	-	NBR	AL
1200	12"	-	-	NBR	AL
050	1/2"	050C.MS	0.15	NBR	MS
075	3/4"	075C.MS	0.23	NBR	MS
100	1"	100C.MS	0.36	NBR	MS
125	1 1/4"	125C.MS	0.49	NBR	MS
150	1 1/2"	150C.MS	0.62	NBR	MS
200	2"	200C.MS	0.77	NBR	MS
250	2 1/2"	250C.MS	1.07	NBR	MS
300	3"	300C.MS	1.58	NBR	MS
400	4"	400C.MS	4.13	NBR	MS
500	5"	500C.MS	3.32	NBR	MS
600	6"	600C.MS	6.05	NBR	MS
800	8"	-	-	NBR	MS
1000	10"	-	-	NBR	MS
1200	12"	-	-	NBR	MS
050	1/2"	050C.PP	0.07	NBR	PP
075	3/4"	075C.PP	0.08	NBR	PP
100	1"	100C.PP	0.12	NBR	PP
125	1 1/4"	125C.PP	0.23	NBR	PP
150	1 1/2"	150C.PP	0.23	NBR	PP
200	2"	200C.PP	0.31	NBR	PP
250	2 1/2"	250C.PP	0.51	NBR	PP
300	3"	300C.PP	0.64	NBR	PP
400	4"	400C.PP	0.91	NBR	PP



Rychlospojka KAMLOK typ C - samice s rýhovaným nátrubkem na hadici

Název	Velikost	Kód	Hmotnost(kg)	Těsnění	Materiál
050	1/2"	050C.SR.SS	0.12	NBR	SS
075	3/4"	075C.SR.SS	0.20	NBR	SS
100	1"	100C.SR.SS	0.29	NBR	SS
125	1 1/4"	125C.SR.SS	0.47	NBR	SS
150	1 1/2"	150C.SR.SS	0.54	NBR	SS
200	2"	200C.SR.SS	0.67	NBR	SS
250	2 1/2"	250C.SR.SS	1.14	NBR	SS
300	3"	300C.SR.SS	1.35	NBR	SS
400	4"	400C.SR.SS	1.97	NBR	SS
500	5"	500C.SR.SS	2.98	NBR	SS
600	6"	600C.SR.SS	4.11	NBR	SS
800	8"	800C.SR.SS	2.60	NBR	SS
1000	10"	-	-	NBR	SS
1200	12"	-	-	NBR	SS



050	1/2"	050C.SR.AL	0.07	NBR	AL
075	3/4"	075C.SR.AL	0.10	NBR	AL
100	1"	100C.SR.AL	0.16	NBR	AL
125	1 1/4"	125C.SR.AL	0.27	NBR	AL
150	1 1/2"	150C.SR.AL	0.30	NBR	AL
200	2"	200C.SR.AL	0.35	NBR	AL
250	2 1/2"	250C.SR.AL	0.43	NBR	AL
300	3"	300C.SR.AL	0.68	NBR	AL
400	4"	400C.SR.AL	0.92	NBR	AL
500	5"	500C.SR.AL	1.81	NBR	AL
600	6"	600C.SR.AL	1.78	NBR	AL
800	8"	800C.SR.AL	4.75	NBR	AL
1000	10"	-	-	NBR	AL
1200	12"	-	-	NBR	AL



050	1/2"	050C.SR.MS	0.15	NBR	BR
075	3/4"	075C.SR.MS	0.23	NBR	BR
100	1"	100C.SR.MS	0.36	NBR	BR
125	1 1/4"	125C.SR.MS	0.49	NBR	BR
150	1 1/2"	150C.SR.MS	0.62	NBR	BR
200	2"	200C.SR.MS	0.77	NBR	BR
250	2 1/2"	250C.SR.MS	1.07	NBR	BR
300	3"	300C.SR.MS	1.58	NBR	BR
400	4"	400C.SR.MS	4.13	NBR	BR
500	5"	500C.SR.MS	3.32	NBR	BR
600	6"	600C.SR.MS	6.05	NBR	BR
800	8"	-	-	NBR	BR
1000	10"	-	-	NBR	BR
1200	12"	-	-	NBR	BR



050	1/2"	050C.SR.PP	0.01	NBR	PP
075	3/4"	075C.SR.PP	0.08	NBR	PP
100	1"	100C.SR.PP	0.12	NBR	PP
125	1 1/4"	125C.SR.PP	0.23	NBR	PP
150	1 1/2"	150C.SR.PP	0.23	NBR	PP
200	2"	200C.SR.PP	0.31	NBR	PP
250	2 1/2"	250C.SR.PP	0.51	NBR	PP
300	3"	300C.SR.PP	0.64	NBR	PP
400	4"	400C.SR.PP	0.91	NBR	PP



*vhodné pro bezpečnostní spony a lisovací objímky (pouze pro SS, MS, AL)

Rychlospojka KAMLOK typ C - samice s hladkým nátrubkem na hadici

Název	Velikost	Kód	Hmotnost(kg)	Těsnění	Materiál
050	1/2"	050C.S.SS	0.12	NBR	SS
075	3/4"	075C.S.SS	0.24	NBR	SS
100	1"	100C.S.SS	0.35	NBR	SS
125	1 1/4"	125C.S.SS	0.59	NBR	SS
150	1 1/2"	150C.S.SS	0.68	NBR	SS
200	2"	200C.S.SS	0.90	NBR	SS
250	2 1/2"	250C.S.SS	1.24	NBR	SS
300	3"	300C.S.SS	1.57	NBR	SS
400	4"	400C.S.SS	2.59	NBR	SS



* Vhodné pro bezpečnostní spony a lisovací objímky.

050	1/2"	050C.S.MS	0.15	NBR	MS
075	3/4"	075C.S.MS	0.25	NBR	MS
100	1"	100C.S.MS	0.38	NBR	MS
125	1 1/4"	125C.S.MS	0.63	NBR	MS
150	1 1/2"	150C.S.MS	0.69	NBR	MS
200	2"	200C.S.MS	0.91	NBR	MS
250	2 1/2"	250C.S.MS	1.18	NBR	MS
300	3"	300C.S.MS	1.57	NBR	MS
400	4"	400C.S.MS	2.71	NBR	MS



* Vhodné pro bezpečnostní spony a lisovací objímky.

Rychlospojka KAMLOK typ D - samice s vnitřním závitem

Název	Závít	Kód	Hmotnost(kg)	Těsnění závitu	Těsnění	Materiál
050	ISO228-1/2"	050D.SS	0.13	PTFE	NBR	SS
075	ISO228-3/4"	075D.SS	0.23	PTFE	NBR	SS
100	ISO228-1"	100D.SS	0.31	PTFE	NBR	SS
125	ISO228-1 1/4"	125D.SS	0.49	PTFE	NBR	SS
150	ISO228-1 1/2"	150D.SS	0.55	PTFE	NBR	SS
200	ISO228-2"	200D.SS	0.71	PTFE	NBR	SS
250	ISO228-2 1/2"	250D.SS	1.01	PTFE	NBR	SS
300	ISO228-3"	300D.SS	1.31	PTFE	NBR	SS
400	ISO228-4"	400D.SS	2.14	PTFE	NBR	SS
500	ISO228-5"	500D.SS	3.54	PTFE	NBR	SS
600	ISO228-6"	600D.SS	4.61	PTFE	NBR	SS
800	ISO228-8"	-	-	PTFE	NBR	SS
1000	ISO228-10"	-	-	PTFE	NBR	SS
1200	ISO228-12"	-	-	PTFE	NBR	SS



050	ISO228-1/2"	050D.AL	0.06	NBR	NBR	AL
075	ISO228-3/4"	075D.AL	0.12	NBR	NBR	AL
100	ISO228-1"	100D.AL	0.16	NBR	NBR	AL
125	ISO228-1 1/4"	125D.AL	0.28	NBR	NBR	AL
150	ISO228-1 1/2"	150D.AL	0.32	NBR	NBR	AL
200	ISO228-2"	200D.AL	0.36	NBR	NBR	AL
250	ISO228-2 1/2"	250D.AL	0.47	NBR	NBR	AL
300	ISO228-3"	300D.AL	0.73	NBR	NBR	AL
400	ISO228-4"	400D.AL	1.21	NBR	NBR	AL
500	ISO228-5"	500D.AL	1.41	NBR	NBR	AL
600	ISO228-6"	600D.AL	2.16	NBR	NBR	AL
800	ISO228-8"	800D.AL	2.61	NBR	NBR	AL
1000	ISO228-10"	-	-	NBR	NBR	AL
1200	ISO228-12"	-	-	NBR	NBR	AL



050	ISO228-1/2"	050D.MS	0.16	NBR	NBR	MS
075	ISO228-3/4"	075D.MS	0.22	NBR	NBR	MS
100	ISO228-1"	100D.MS	0.32	NBR	NBR	MS
125	ISO228-1 1/4"	125D.MS	0.46	NBR	NBR	MS
150	ISO228-1 1/2"	150D.MS	0.54	NBR	NBR	MS
200	ISO228-2"	200D.MS	0.67	NBR	NBR	MS
250	ISO228-2 1/2"	250D.MS	0.94	NBR	NBR	MS
300	ISO228-3"	300D.MS	1.40	NBR	NBR	MS
400	ISO228-4"	400D.MS	2.09	NBR	NBR	MS
500	ISO228-5"	500D.MS	2.58	NBR	NBR	MS
600	ISO228-6"	600D.MS	5.02	NBR	NBR	MS
800	ISO228-8"	-	-	NBR	NBR	MS
1000	ISO228-10"	-	-	NBR	NBR	MS
1200	ISO228-12"	-	-	NBR	NBR	MS



050	ISO228-1/2"	050D.PP	0.07	NBR	NBR	PP
075	ISO228-3/4"	075D.PP	0.08	NBR	NBR	PP
100	ISO228-1"	100D.PP	0.13	NBR	NBR	PP
125	ISO228-1 1/4"	125D.PP	0.21	NBR	NBR	PP
150	ISO228-1 1/2"	150D.PP	0.23	NBR	NBR	PP
200	ISO228-2"	200D.PP	0.27	NBR	NBR	PP
250	ISO228-2 1/2"	250D.PP	0.44	NBR	NBR	PP
300	ISO228-3"	300D.PP	0.50	NBR	NBR	PP
400	ISO228-4"	400D.PP	0.75	NBR	NBR	PP



KAMLOK typu D je možné dodat i se závitem NPT nebo BSP

Vsuvka KAMLOK typ E - samec s nátrubkem na hadici

Název	Velikost	Kód	Hmotnost(kg)	Materiál
050	1/2"	050E.SS	0.07	SS
075	3/4"	075E.SS	0.14	SS
100	1"	100E.SS	0.25	SS
125	1 1/4"	125E.SS	0.37	SS
150	1 1/2"	150E.SS	0.56	SS
200	2"	200E.SS	0.85	SS
250	2 1/2"	250E.SS	1.17	SS
300	3"	300E.SS	1.73	SS
400	4"	400E.SS	2.85	SS
500	5"	500E.SS	4.05	SS
600	6"	600E.SS	5.64	SS
800	8"	-	10.11	SS
1000	10"	-	-	SS
1200	12"	-	-	SS
050	1/2"	050E.AL	0.03	AL
075	3/4"	075E.AL	0.05	AL
100	1"	100E.AL	0.09	AL
125	1 1/4"	125E.AL	0.12	AL
150	1 1/2"	150E.AL	0.19	AL
200	2"	200E.AL	0.28	AL
250	2 1/2"	250E.AL	0.45	AL
300	3"	300E.AL	0.66	AL
400	4"	400E.AL	1.13	AL
500	5"	500E.AL	1.48	AL
600	6"	600E.AL	2.21	AL
800	8"	800E.AL	3.61	AL
1000	10"	-	-	AL
1200	12"	-	-	AL
050	1/2"	050E.MS	0.11	MS
075	3/4"	075E.MS	0.16	MS
100	1"	100E.MS	0.24	MS
125	1 1/4"	125E.MS	0.33	MS
150	1 1/2"	150E.MS	0.44	MS
200	2"	200E.MS	0.73	MS
250	2 1/2"	250E.MS	0.96	MS
300	3"	300E.MS	1.25	MS
400	4"	400E.MS	1.91	MS
500	5"	500E.MS	4.54	MS
600	6"	600E.MS	5.07	MS
800	8"	-	-	MS
1000	10"	-	-	MS
1200	12"	-	-	MS
050	1/2"	050E.PP	0.01	PP
075	3/4"	075E.PP	0.03	PP
100	1"	100E.PP	0.04	PP
125	1 1/4"	125E.PP	0.07	PP
150	1 1/2"	150E.PP	0.09	PP
200	2"	200E.PP	0.15	PP
250	2 1/2"	250E.PP	0.25	PP
300	3"	300E.PP	0.35	PP
400	4"	400E.PP	0.55	PP



Vsuvka KAMLOK typ E - samec s rýhovaným nátrubkem na hadici

Název	Velikost	Kód	Hmotnost(kg)	Materiál
050	1/2"	050E.SR.SS	0.07	SS
075	3/4"	075E.SR.SS	0.14	SS
100	1"	100E.SR.SS	0.25	SS
125	1 1/4"	125E.SR.SS	0.37	SS
150	1 1/2"	150E.SR.SS	0.56	SS
200	2"	200E.SR.SS	0.85	SS
250	2 1/2"	250E.SR.SS	1.17	SS
300	3"	300E.SR.SS	1.73	SS
400	4"	400E.SR.SS	2.85	SS
500	5"	500E.SR.SS	4.05	SS
600	6"	600E.SR.SS	5.64	SS
800	8"	800E.SR.SS	10.11	SS
1000	10"	-	-	SS
1200	12"	-	-	SS

050	1/2"	050E.SR.AL	0.03	AL
075	3/4"	075E.SR.AL	0.05	AL
100	1"	100E.SR.AL	0.09	AL
125	1 1/4"	125E.SR.AL	0.12	AL
150	1 1/2"	150E.SR.AL	0.19	AL
200	2"	200E.SR.AL	0.28	AL
250	2 1/2"	250E.SR.AL	0.45	AL
300	3"	300E.SR.AL	0.66	AL
400	4"	400E.SR.AL	1.13	AL
500	5"	500E.SR.AL	1.48	AL
600	6"	600E.SR.AL	2.21	AL
800	8"	800E.SR.AL	3.61	AL
1000	10"	-	-	AL
1200	12"	-	-	AL

050	1/2"	050E.SR.MS	0.11	MS
075	3/4"	075E.SR.MS	0.16	MS
100	1"	100E.SR.MS	0.24	MS
125	1 1/4"	125E.SR.MS	0.33	MS
150	1 1/2"	150E.SR.MS	0.44	MS
200	2"	200E.SR.MS	0.73	MS
250	2 1/2"	250E.SR.MS	0.96	MS
300	3"	300E.SR.MS	1.25	MS
400	4"	400E.SR.MS	1.91	MS
500	5"	500E.SR.MS	4.54	MS
600	6"	600E.SR.MS	5.07	MS
800	8"	800E.SR.MS	7.13	MS
1000	10"	-	-	MS
1200	12"	-	-	MS

050	1/2"	050E.SR.PP	0.01	PP
075	3/4"	075E.SR.PP	0.03	PP
100	1"	100E.SR.PP	0.04	PP
125	1 1/4"	125E.SR.PP	0.07	PP
150	1 1/2"	150E.SR.PP	0.09	PP
200	2"	200E.SR.PP	0.15	PP
250	2 1/2"	250E.SR.PP	0.25	PP
300	3"	300E.SR.PP	0.35	PP
400	4"	400E.SR.PP	0.55	PP
600	6"	600E.SR.PP	0.75	PP



*vhodné pro bezpečnostní spony a lisovací objímky (pouze pro SS MS AL)

Vsuvka KAMLOK typ E - samec s hladkým nátrubkem na hadici

Název	Velikost	Kód	Hmotnost(kg)	Materiál
050	1/2"	050E.S.SS	0.07	SS
075	3/4"	075E.S.SS	0.13	SS
100	1"	100E.S.SS	0.20	SS
125	1 1/4"	125E.S.SS	0.33	SS
150	1 1/2"	150E.S.SS	0.45	SS
200	2"	200E.S.SS	0.58	SS
250	2 1/2"	250E.S.SS	0.96	SS
300	3"	300E.S.SS	1.16	SS
400	4"	400E.S.SS	2.26	SS



* Vhodné pro bezpečnostní spony a lisovací objímky.

050	1/2"	050E.S.MS	0.11	MS
075	3/4"	075E.S.MS	0.14	MS
100	1"	100E.S.MS	0.21	MS
125	1 1/4"	125E.S.MS	0.35	MS
150	1 1/2"	150E.S.MS	0.45	MS
200	2"	200E.S.MS	0.66	MS
250	2 1/2"	250E.S.MS	0.98	MS
300	3"	300E.S.MS	1.26	MS
400	4"	400E.S.MS	2.69	MS



* Vhodné pro bezpečnostní spony a lisovací objímky.

Vsuvka KAMLOK typ F - samec s vnějším závitem

Název	Závit	Kód	Hmotnost(kg)	Materiál
050	R2999-1/2"	050F.SS	0.13	SS
075	R2999-3/4"	075F.SS	0.18	SS
100	R2999-1"	100F.SS	0.25	SS
125	R2999-1 1/4"	125F.SS	0.43	SS
150	R2999-1 1/2"	150F.SS	0.51	SS
200	R2999-2"	200F.SS	0.76	SS
250	R2999-2 1/2"	250F.SS	0.84	SS
300	R2999-3"	300F.SS	1.01	SS
400	R2999-4"	400F.SS	1.73	SS
500	R2999-5"	500F.SS	2.74	SS
600	R2999-6"	600F.SS	4.28	SS
800	R2999-8"	-	5.31	SS
1000	R2999-10"	-	-	SS
1200	R2999-12"	-	-	SS
050	R2999-1/2"	050F.AL	0.05	AL
075	R2999-3/4"	075F.AL	0.11	AL
100	R2999-1"	100F.AL	0.14	AL
125	R2999-1 1/4"	125F.AL	0.24	AL
150	R2999-1 1/2"	150F.AL	0.27	AL
200	R2999-2"	200F.AL	0.33	AL
250	R2999-2 1/2"	250F.AL	0.41	AL
300	R2999-3"	300F.AL	0.65	AL
400	R2999-4"	400F.AL	0.92	AL
500	R2999-5"	500F.AL	1.16	AL
600	R2999-6"	600F.AL	1.78	AL
800	R2999-8"	800F.AL	4.21	AL
1000	R2999-10"	-	-	AL
1200	R2999-12"	-	-	AL
050	R2999-1/2"	050F.MS	0.12	MS
075	R2999-3/4"	075F.MS	0.13	MS
100	R2999-1"	100F.MS	0.27	MS
125	R2999-1 1/4"	125F.MS	0.41	MS
150	R2999-1 1/2"	150F.MS	0.48	MS
200	R2999-2"	200F.MS	0.61	MS
250	R2999-2 1/2"	250F.MS	0.77	MS
300	R2999-3"	300F.MS	1.21	MS
400	R2999-4"	400F.MS	1.87	MS
500	R2999-5"	500F.MS	2.11	MS
600	R2999-6"	600F.MS	3.72	MS
800	R2999-8"	-	-	MS
1000	R2999-10"	-	-	MS
1200	R2999-12"	-	-	MS
050	R2999-1/2"	050F.PP	0.07	PP
075	R2999-3/4"	075F.PP	0.07	PP
100	R2999-1"	100F.PP	0.11	PP
125	R2999-1 1/4"	125F.PP	0.21	PP
150	R2999-1 1/2"	150F.PP	0.22	PP
200	R2999-2"	200F.PP	0.24	PP
250	R2999-2 1/2"	250F.PP	0.36	PP
300	R2999-3"	300F.PP	0.43	PP
400	R2999-4"	400F.PP	0.67	PP



KAMLOK typu F je možné dodat i se závitem NPT

VÍČKO pro vsuvku KAMLOK typ DC - samice

Název	Velikost	Kód	Hmotnost(kg)	Těsnění	Materiál
050	1/2"	050DC.SS	0.13	NBR	SS
075	3/4"	075DC.SS	0.18	NBR	SS
100	1"	100DC.SS	0.25	NBR	SS
125	1 1/4"	125DC.SS	0.43	NBR	SS
150	1 1/2"	150DC.SS	0.51	NBR	SS
200	2"	200DC.SS	0.76	NBR	SS
250	2 1/2"	250DC.SS	0.84	NBR	SS
300	3"	300DC.SS	1.01	NBR	SS
400	4"	400DC.SS	1.73	NBR	SS
500	5"	500DC.SS	2.74	NBR	SS
600	6"	600DC.SS	4.28	NBR	SS
800	8"	-	-	NBR	SS
1000	10"	-	-	NBR	SS
1200	12"	-	-	NBR	SS



050	1/2"	050DC.AL	0.05	NBR	AL
075	3/4"	075DC.AL	0.11	NBR	AL
100	1"	100DC.AL	0.14	NBR	AL
125	1 1/4"	125DC.AL	0.24	NBR	AL
150	1 1/2"	150DC.AL	0.27	NBR	AL
200	2"	200DC.AL	0.33	NBR	AL
250	2 1/2"	250DC.AL	0.41	NBR	AL
300	3"	300DC.AL	0.65	NBR	AL
400	4"	400DC.AL	0.92	NBR	AL
500	5"	500DC.AL	1.16	NBR	AL
600	6"	600DC.AL	1.78	NBR	AL
800	8"	800DC.AL	4.21	NBR	AL
1000	10"	-	-	NBR	AL
1200	12"	-	-	NBR	AL



050	1/2"	050DC.MS	0.12	NBR	MS
075	3/4"	075DC.MS	0.13	NBR	MS
100	1"	100DC.MS	0.27	NBR	MS
125	1 1/4"	125DC.MS	0.41	NBR	MS
150	1 1/2"	150DC.MS	0.48	NBR	MS
200	2"	200DC.MS	0.61	NBR	MS
250	2 1/2"	250DC.MS	0.77	NBR	MS
300	3"	300DC.MS	1.21	NBR	MS
400	4"	400DC.MS	1.87	NBR	MS
500	5"	500DC.MS	2.11	NBR	MS
600	6"	600DC.MS	3.72	NBR	MS
800	8"	-	-	NBR	MS
1000	10"	-	-	NBR	MS
1200	12"	-	-	NBR	MS



050	1/2"	050DC.PP	0.07	-	PP
075	3/4"	075DC.PP	0.07	-	PP
100	1"	100DC.PP	0.11	-	PP
125	1 1/4"	125DC.PP	0.21	-	PP
150	1 1/2"	150DC.PP	0.22	-	PP
200	2"	200DC.PP	0.24	-	PP
250	2 1/2"	250DC.PP	0.36	-	PP
300	3"	300DC.PP	0.43	-	PP
400	4"	400DC.PP	0.67	-	PP



* na zažádání lze přidat řetízek

ZÁTKA pro rychlospojku KAMLOK typ DP - samec

Název	Velikost	Kód	Hmotnost(kg)	Příslušenství	Materiál
050	1/2"	050DP.SS	0.06	Řetízek	SS
075	3/4"	075DP.SS	0.08	Řetízek	SS
100	1"	100DP.SS	0.13	Řetízek	SS
125	1 1/4"	125DP.SS	0.25	Řetízek	SS
150	1 1/2"	150DP.SS	0.32	Řetízek	SS
200	2"	200DP.SS	0.46	Řetízek	SS
250	2 1/2"	250DP.SS	0.67	Řetízek	SS
300	3"	300DP.SS	0.93	Řetízek	SS
400	4"	400DP.SS	1.59	Řetízek	SS
500	5"	500DP.SS	1.91	Řetízek	SS
600	6"	600DP.SS	3.84	Řetízek	SS
800	8"	-	-	Řetízek	SS
1000	10"	-	-	Řetízek	SS
1200	12"	-	-	Řetízek	SS
050	1/2"	050DP.AL	0.02	Řetízek	AL
075	3/4"	075DP.AL	0.03	Řetízek	AL
100	1"	100DP.AL	0.05	Řetízek	AL
125	1 1/4"	125DP.AL	0.07	Řetízek	AL
150	1 1/2"	150DP.AL	0.12	Řetízek	AL
200	2"	200DP.AL	0.16	Řetízek	AL
250	2 1/2"	250DP.AL	0.22	Řetízek	AL
300	3"	300DP.AL	0.28	Řetízek	AL
400	4"	400DP.AL	0.51	Řetízek	AL
500	5"	500DP.AL	0.55	Řetízek	AL
600	6"	600DP.AL	0.74	Řetízek	AL
800	8"	800DP.AL	4.21	Řetízek	AL
1000	10"	-	-	Řetízek	AL
1200	12"	-	-	Řetízek	AL
050	1/2"	050DP.MS	0.07	Řetízek	MS
075	3/4"	075DP.MS	0.09	Řetízek	MS
100	1"	100DP.MS	0.13	Řetízek	MS
125	1 1/4"	125DP.MS	0.21	Řetízek	MS
150	1 1/2"	150DP.MS	0.24	Řetízek	MS
200	2"	200DP.MS	0.41	Řetízek	MS
250	2 1/2"	250DP.MS	0.59	Řetízek	MS
300	3"	300DP.MS	0.72	Řetízek	MS
400	4"	400DP.MS	1.03	Řetízek	MS
500	5"	500DP.MS	1.61	Řetízek	MS
600	6"	600DP.MS	1.81	Řetízek	MS
800	8"	-	-	Řetízek	MS
1000	10"	-	-	Řetízek	MS
1200	12"	-	-	Řetízek	MS
050	1/2"	050DP.PP	0.01	Řetízek	PP
075	3/4"	075DP.PP	0.01	Řetízek	PP
100	1"	100DP.PP	0.02	Řetízek	PP
125	1 1/4"	125DP.PP	0.04	Řetízek	PP
150	1 1/2"	150DP.PP	0.05	Řetízek	PP
200	2"	200DP.PP	0.08	Řetízek	PP
250	2 1/2"	250DP.PP	0.17	Řetízek	PP
300	3"	300DP.PP	0.22	Řetízek	PP
400	4"	400DP.PP	0.26	Řetízek	PP



* na zažádání lze přidat řetízek

VÍČKO pro vsuvku KAMLOK typ DC - samice - speciální provedení

Název	Velikost	Kód	Hmotnost(kg)	Těsnění	Materiál
DN 32	1 1/4"	125DC.S.AL	0.24	NBR	AL
DN 40	1 1/2"	150DC.S.AL	0.27	NBR	AL
DN 50	2"	200DC.S.AL	0.33	NBR	AL
DN 65	2 1/2"	250DC.S.AL	0.41	NBR	AL
DN 80	3"	300DC.S.AL	0.65	NBR	AL



Vsuvka KAMLOK typ FW - samec s navařovacím nátrubkem na hadici

Název	Velikost svaru	Kód	Hmotnost(kg)	Materiál
DN15	21.3*2.3	050FW.SS	0.07	SS
DN20	26.9*2.3	075FW.SS	0.11	SS
DN25	33.7*2.6	100FW.SS	0.15	SS
DN32	42.2*2.6	125FW.SS	0.24	SS
DN40	48.3*2.6	150FW.SS	0.32	SS
DN50	60.3*2.9	200FW.SS	0.42	SS
DN65	76.1*2.9	250FW.SS	0.71	SS
DN80	88.9*3.2	300FW.SS	0.73	SS
DN100	114.3*3.6	400FW.SS	1.42	SS
DN125	139.7*3.6	500FW.SS	-	SS
DN150	168.3*4.5	600FW.SS	-	SS



Rychlospojka KAMLOK typ BW - samice s navařovacím nátrubkem na hadici

Název	Velikost svaru	Kód	Hmotnost(kg)	Těsnění	Materiál
DN15	21.3*2.3	050BW.SS	0.12	NBR	SS
DN20	26.9*2.3	075BW.SS	0.20	NBR	SS
DN25	33.7*2.6	100BW.SS	0.29	NBR	SS
DN32	42.2*2.6	125BW.SS	0.47	NBR	SS
DN40	48.3*2.6	150BW.SS	0.54	NBR	SS
DN50	60.3*2.9	200BW.SS	0.67	NBR	SS
DN65	76.1*2.9	250BW.SS	1.14	NBR	SS
DN80	88.9*3.2	300BW.SS	1.35	NBR	SS
DN100	114.3*3.6	400BW.SS	1.97	NBR	SS
DN125	139.7*4	500BW.SS	2.98	NBR	SS
DN150	168.3*4.5	600BW.SS	4.11	NBR	SS

