

ETF Series

Tanktop Mounted Return Line Filters
max. 175 l/min - 6 bar



An economic return line filter

Improved system protection

The ETF Series utilizes a re-inforced co-polymer head equipped with 2 return ports and quick-release cover. Maximum pressure 6 bar. Maximum flow 175 l/min. An economic return line filter that has been used and proven in many hydraulic filtration applications.



Contact Information:

Parker Hannifin
Hydraulic Filter Division Europe

**European Product
Information Centre**
Freephone: 00800 27 27 5374
(from AT, BE, CH, CZ, DE, EE, ES,
FI, FR, IE, IT, PT, SE, SK, UK)
filtrationinfo@parker.com

www.parker.com/hfde

Product Features:

- ETF utilizes a re-inforced co-polymer head equipped with 2 return ports.
- Quick-release cover design.
- Flow from inside to out.
- Maximum pressure 6 bar. Maximum flow 175 l/min.
- An economic return line filter for hydraulic systems.

ETF Series

Tanktop Mounted Return Line Filters

Features & Benefits

Features	Advantages	Benefits
Co-polymer head	Compact profile, lightweight and durable	Less weight, smaller envelope and cleaner appearance
Multiple return line ports	Flexibility related to return line hose(s) arrangement	More compact solutions can be realised
Quick release cover	No tools required to release the filter cover	Easy change of filter element
Optional magnetic pre-filtration	Removes ferro particles, even during bypass conditions	Improved fluid cleanliness levels
In-to-Out filtration	All captured contamination retains inside the element	No recontamination of system during change of elements
Quick response bypass with low hysteresis	Reduction of bypass period due to low hysteresis	Improved protection of system
	Only a small part of the total flow is bypassing the element	
Optional funnel	Ensures that oil enters the tank under the oil level	Significant reduction of oil foaming

Typical Applications

- Lorry mounted cranes
- Agricultural equipment
- Container hook loaders

The Parker Filtration ETF Series Low Pressure Filters

For tank top mounting installation. The ETF Series utilises a reinforced co-polymer head equipped with two return ports and quick release cover. This filter represents an economic solution for hydraulic systems with nominal flows up to 175 l/min.



Specification

Pressure ratings:

Max. 6 bar.

Assembly:

Tank top mounted.

Connections:

Threads G1" + G1" (ISO 228), port B supplied as plugged connection.

Filter housing:

Glass reinforced co-polymer.
Funnel made from steel.

Seal material:

Nitrile.

Operating temperature range:

-20° to +80°C.

Bypass valve:

Opening pressure 1.6 bar.

Filter element:

Conventional style element with steel end caps.

Degree of filtration:

Determined by multipass test according to ISO 16889.

Flow fatigue characteristics:

Filter media is supported so that the optimum fatigue life is achieved.

Filtration media:

Microglass III.

Element burst rating:

8 bar (ISO 2941).

Indicator options:

Setting 1.0 bar.

Fluid compatibility:

Suitable for use with mineral and vegetable oils, and some synthetic oils. For other fluids, please consult Parker Filtration.

Installation Details

ETF Length	Dimensions mm (inches)	A	B
1	ETF45	82 (3.22)	100 (3.94)
2	ETF60	106 (4.17)	125 (4.92)
3	ETF90	150 (5.90)	177 (6.97)
4	ETF120	200 (7.87)	225 (8.86)
4A	ETF140	260 (10.24)	300 (11.81)
4B	ETF175	350 (13.78)	375 (14.76)

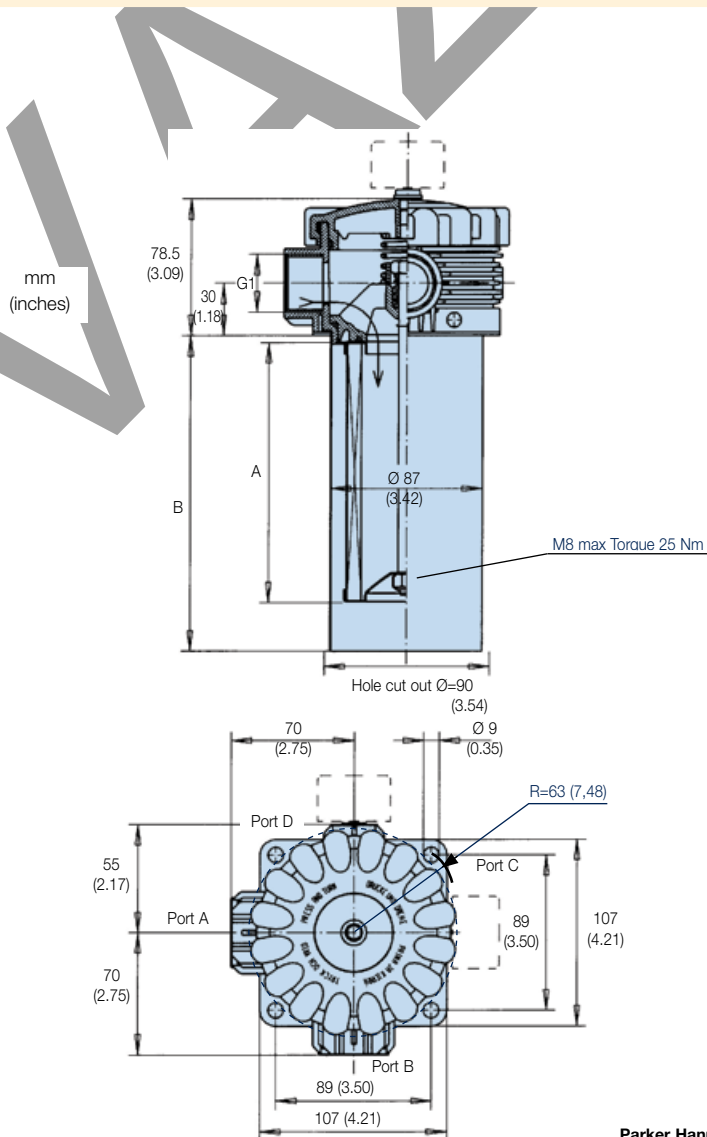

ETF Series

Tanktop Mounted Return Line Filters

Indicator Details

Visual pressure indicator

Code G2
mm (inches)

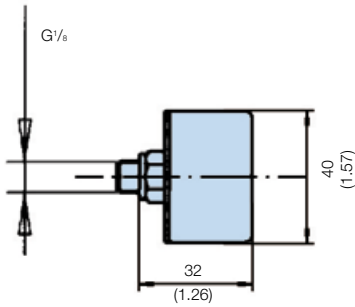

48 Vdc electrical indicator 1.2 bar

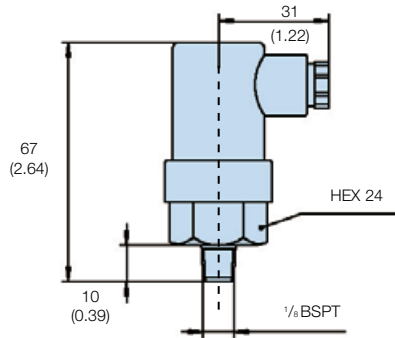

Code S2/S3
mm (inches)

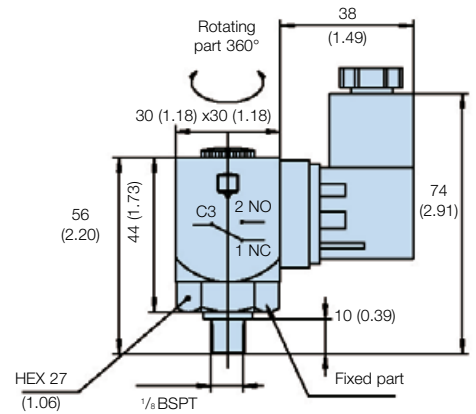

250 VAC electrical indicator 1.2 bar

Code S4
mm (inches)



Option	Description	Connection/Voltage	Wiring	Part number						
G2	Visual indicator 1.0 bar	N/A	N/A	FMUG2FBMG02L						
S2/S3	Electrical indicator 1.0 bar	42 Vdc max	 Select either normally open (NO) or normally closed (NC)	FMUS2FBMG02L or FMUS3FBMG02L						
S4	Electrical indicator 1.0 bar	250 VAC max	 <table border="1" data-bbox="877 1299 981 1377"> <tr> <td>1</td> <td>NC</td> </tr> <tr> <td>2</td> <td>NO</td> </tr> <tr> <td>3</td> <td>C</td> </tr> </table>	1	NC	2	NO	3	C	FMUS4FFAG02L
1	NC									
2	NO									
3	C									

Normally open contacts

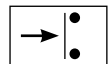

Normally closed contacts

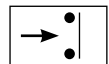

Pressure Drop Curves

The recommended level of the initial pressure drop for low pressure filters is max 0.5 bar.

If the medium used has a viscosity different from 32cSt, pressure drop over the filter can be estimated as follows:

$$\Delta p = (\Delta p_{32} \times \text{viscosity of medium used}) / 32\text{cSt}$$

ETF45 (Element length code 1)

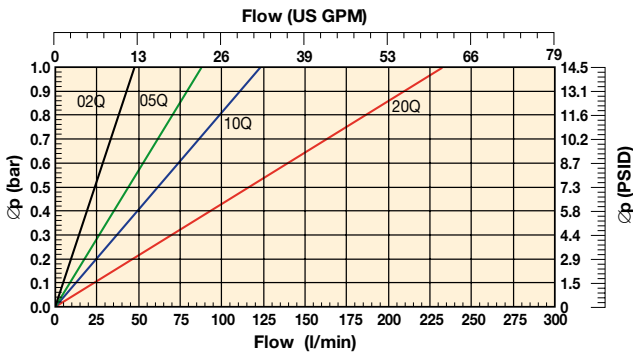

ETF60 (Element length code 2)

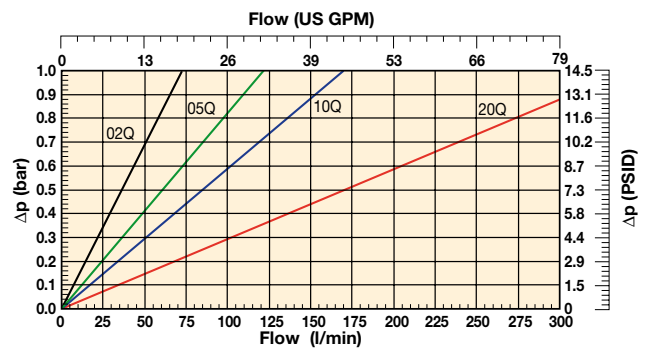

ETF90 (Element length code 3)

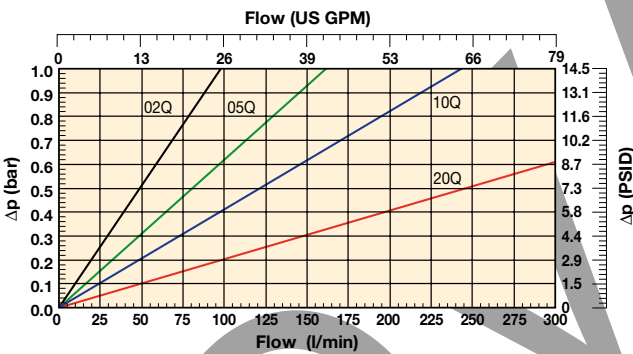

ETF120 (Element length code 4)

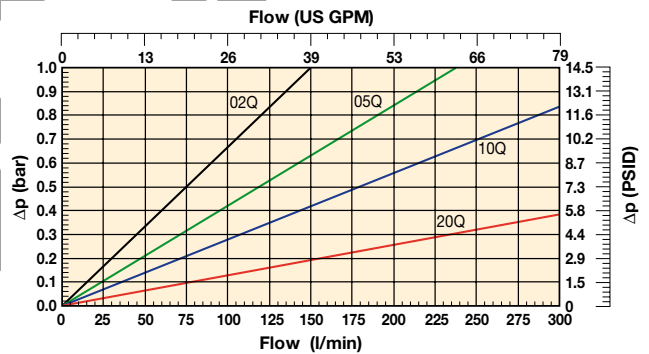

ETF140 (Element length code 4A)

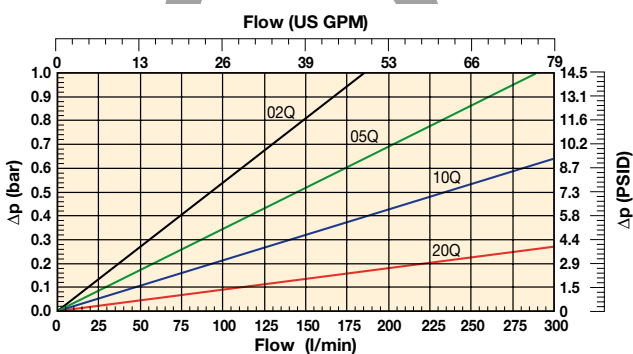

ETF175 (Element length code 4B)

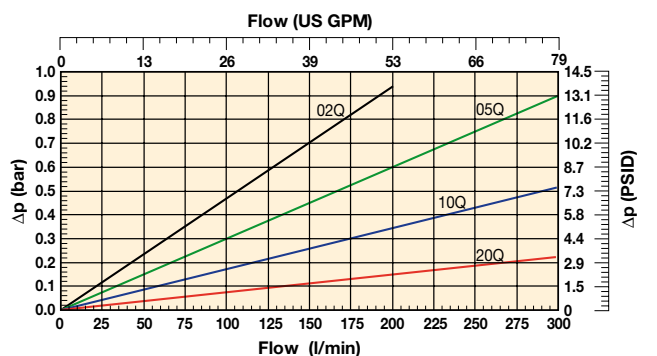

Note: All pressure drop curves above show total pressure drop. i.e. they are combined housing and element curves.

ETF Series

Tanktop Mounted Return Line Filters

Ordering Information

Standard products table

Part number	Supersedes	Flow (l/min)	Model number	Element length	Media rating (µ)	Seals	Indicator	Bypass settings	Ports	Included options	Replacement elements	Supersedes
ETF210QBP2FG164	FK1230.Q010.BK16.GX16	60	ETF60	Length 2	10	Nitrile	Plugged	1.6 Bar (23 Psi)	2xG1 (one port plugged)	Diffuser type P	937950Q	FC1230.Q010.XS
ETF220QBP2FG164	FK1230.Q020.BK16.GX16	60	ETF60	Length 2	20	Nitrile	Plugged	1.6 Bar (23 Psi)	2xG1 (one port plugged)	Diffuser type P	937951Q	FC1230.Q020.XS
ETF310QBP2FG164	FK1240.Q010.BK16.GX16	90	ETF90	Length 3	10	Nitrile	Plugged	1.6 Bar (23 Psi)	2xG1 (one port plugged)	Diffuser type P	937952Q	FC1240.Q010.XS
ETF320QBP2FG164	FK1240.Q020.BK16.GX16	90	ETF90	Length 3	20	Nitrile	Plugged	1.6 Bar (23 Psi)	2xG1 (one port plugged)	Diffuser type P	937953Q	FC1240.Q020.XS

Note: Filter assemblies ordered from the product configurator below are on extended lead times. Where possible, please make your selection from the table above.

Product configurator

Configurator example of an ETF Series filter

Box 1	Box 2	Box 3	Box 4	Box 5	Box 6	Box 7	Box 8
ETF	3	10Q	B	S2	F	G16	1

Code	Filter type
ETF	Housing
	ETF 1-45
	ETF 1-60
	ETF 1-90
	ETF 1-120
	ETF 1-140
	ETF 1-175

Degree of filtration
Glassfibre media
Microglass III (for disposable elements)
Disposable element
02Q
05Q
10Q
20Q

Seal type
Seal material
Nitrile
Code
B

Indicator
Code
Pressure gauge, setting 1.2 bar, G ¹ / ₈
G2
Pressure switch 42V, 1.2 bar setting, NO with G ¹ / ₈ BSP
S2
Pressure switch 42V, 1.2 bar setting, NC with G ¹ / ₈ BSP
S3
Pressure switch 250V, 1.2 bar setting NO/NC with G ¹ / ₈
S4
No indicator, indicator ports L + T plugged
P2
Other settings for indicators / gauges on request
on request

Bypass valve
Bypass valve
1.6 bar
Code
F
Other bypass settings
on request

Filter connection
Ports
G1 ¹ (BSP) (2 ports, one supplied as plugged connection)
Code
G16

Options
Options
No diffuser required
Code
1
Diffuser type P without perforated plate area
4
Diffuser with integrated hose connection
on request
Magnets
on request
Diffuser type P and magnets
on request
Other combinations
on request

Note: ETF filters are standard supplied without magnets and including diffuser type P

Spare elements table				
	02Q	05Q	10Q	20Q
ETF1-45	937969Q	937970Q	937948Q	937949Q
ETF1-60	937971Q	937972Q	937950Q	937951Q
ETF1-90	937973Q	937974Q	937952Q	937953Q
ETF1-120	937975Q	937976Q	937954Q	937955Q
ETF1-140	937977Q	937978Q	937956Q	937957Q
ETF1-175	937979Q	937980Q	937981Q	937982Q

Degree of filtration						
Average filtration beta ratio β (ISO 16889) / particle size µm [c]						
βx(c)=2	βx(c)=10	βx(c)=75	βx(c)=100	βx(c)=200	βx(c)=1000	Media code
% efficiency, based on the above beta ratio (βx)						
50.0%	90.0%	98.7%	99.0%	99.5%	99.9%	
N/A	N/A	N/A	N/A	N/A	4.5	
N/A	N/A	4.5	5	6	7	
N/A	6	8.5	9	10	12	
6	11	17	18	20	22	

ETF Series Seal Kit	
Part Number	Description
918045037	NITRILE SEAL KIT ETF 0 -4B

Highlights Key (Denotes part number availability)

123	Item is standard
123	Item is standard green option
123	Item is semi standard
123	Item is non standard

Note 1: Part numbers featured with bold highlighted codes will ensure a 'standard' product selection.

Note 2: Alternate displayed part number selection will require you to contact Parker Filtration for availability.



TTF Series

Tanktop Mounted Return Line Filters

Max 500 l/min - 10 bar



Featuring pre-filtration by means of a magnetic column

Extended element life time

The TTF Series features pre-filtration by means of a magnet column and a quick response bypass with low hysteresis. Maximum pressure 10 bar. Maximum flow 500 l/min. A second return port is an available option as is a filling port in the filter cover.



Contact Information:

Parker Hannifin
Hydraulic Filter Division Europe

European Product
Information Centre
Freephone: 00800 27 27 5374
(from AT, BE, CH, CZ, DE, EE, ES,
FI, FR, IE, IT, PT, SE, SK, UK)
filtrationinfo@parker.com

www.parker.com/hfde

Product Features:

- TTF features pre-filtration by means of a magnet column.
- Quick response bypass with low hysteresis.
- Maximum pressure 10 bar. Maximum flow 500 l/min.
- Options include a filling port in the filter cover and second return port.
- Patented *LEIF*® elements safeguard filtration quality.
- Flow from inside to out.

TTF Series

Tanktop Mounted Return Line Filters

Features & Benefits

Features	Advantages	Benefits
10 bar rated filter	Can be utilised for severe return line applications	Reduced downtime due to premature filter failures
Cast aluminium head	Compact profile, lightweight and durable	Less weight, smaller envelop and cleaner appearance
LEIF® elements	Element safeguards the use of genuine parts	Guaranteed quality of filtration Contributes to ISO 14001 certification
Magnetic pre-filtration	Removes ferrous particles, even during bypass conditions	Improved fluid cleanliness levels Extended element life time
In-to-Out filtration	All captured contamination retains inside the element	No recontamination of system during change of elements
High level of customisation	Dedicated system-matched solutions can be easily made available	Improved integration of filter in system combined with lower initial system costs
Quick response bypass with low hysteresis	Reduction of bypass period due to low hysteresis	Improved protection of system
	Only a small part of the total flow is bypassing the element	
Standard or customised funnel	Ensures that oil enters the tank under the oil level	Significant reduction of oil foaming

Typical Applications

- Waste management trucks
- Mobile cranes
- Power packs
- Wheeled loaders
- Drilling equipment

The Parker Filtration TTF Series Return Line Filters

TTF tank top mounted return line filters feature pre-filtration by means of a magnet column and a quick response bypass with low hysteresis. Thanks to the “In-to-Out” filter principle, contaminated oil cannot leak back into the system. TTF filters are available in versions capable of handling flow rates up to 500 l/min. They can operate up to a maximum working pressure of 10 bar. Optional filling port in filter cover, second return port and customised diffusers can be specified.



Specification

Operation pressure:

Max. 10 bar.

Assembly:

Tank top mounted.

Connections:

Threaded BSP ports.
Flanged ports on request.

Filter housing:

Aluminium head and cover.

Seal material:

Nitrile, fluoroelastomer, neoprene.

Operation temperature range:

Seal material Nitrile: -40 to +100°C.
Seal material Fluoroelastomer: -20 to +120°C.

Bypass setting

Opening pressure 0.8 / 1.5 or 2 bar.
Other settings on request.

Degree of filtration:

Determined by multipass test according to ISO 16889.

Flow fatigue characteristics:

Filter media is supported so that the optimum fatigue life is achieved.

Filtration media:

Microglass III and Ecoglass III for *LEIF*[®] elements.
Also available 10µm cellulose and 40µm stainless steel mesh.

Element burst rating:

10 bar (ISO 2941)

Pressure indicator options:

Setting 0.7 or 1.2 bar.
Other settings on request.
Visual pressure gauge.
Electrical pressure switch.

Options:

Diffuser type P (straight pipe, no perforated plate area)
Diffuser type T (with closed diffuser end cap and with perforated plate area, recommended when oil entry in reservoir is close to the reservoir bottom or to ensure oil entry under the reservoir oil level)

Magnetic pack:

Standard. TTF400 and 500 are standard supplied without magnets

Filling port in cover: (optional)

Plugged.

Filter element:

LEIF[®] element with reusable metal element sleeve.

Optional conventional style element with steel end caps.

The *LEIF*[®] element is patented and safeguards the use of genuine parts.

Note: *LEIF*[®] element can be used with mineral and HEES type oils.

For other fluids consult Parker Filtration.

LEIF[®] contributes to ISO 14001 quality standards.

TTF

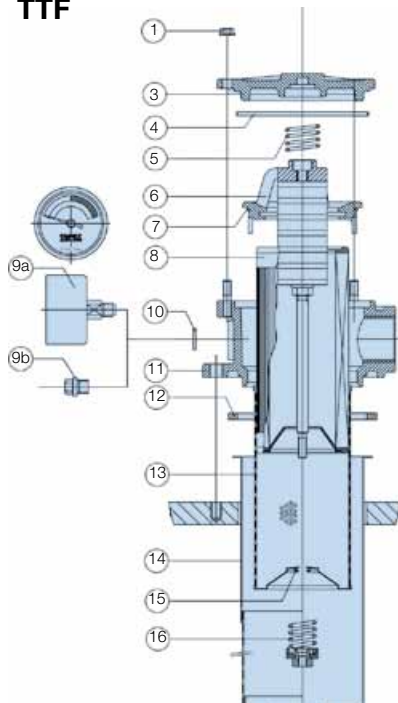

TTF sealkit: No. 4+7+12

Ref.	No.	Description
1	4	Flange nut
3	1	Cover
4	1	Cover-seal
5	1	Top-spring
6	1	Insert
7	1	Insert-seal
8	1	Element
9a	0-1	Indicator
9b	0-3	Plug M10x1
10	0-3	Unit-ring
11	1	Housing
12	1	Gasket
13	1	Sleeve
14	1	Funnel/diffuser
15	1	O-ring
16	1	Bypass set

TTF Series

Tanktop Mounted Return Line Filters

TTF Lengths 2-5 Single port

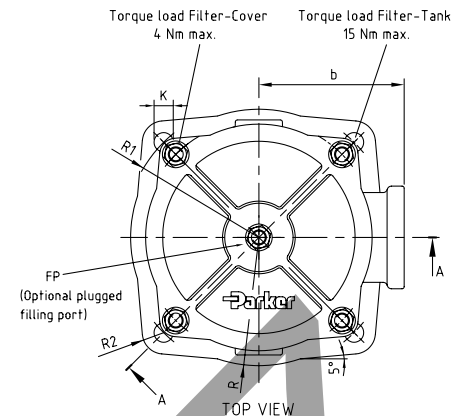
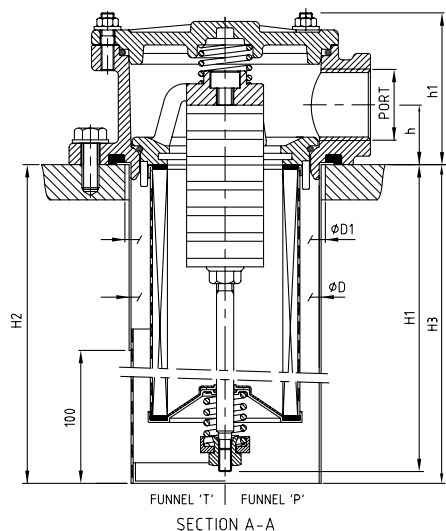

TTF length	Type	Port option	h	h1	ØD	ØD1	H1	H2	H3	b	R	R1	R2	K	FP
2	TTF 1-60	G ³ / ₄ , G1	28	73	Ø90	Ø93	131	190	190	68	60	63	10	4xØ9	G ¹ / ₂
3	TTF 1-90						175	190	190						
4	TTF 1-120						225	330	330						
5	TTF 1-150						325	420	420						

Dimensions in mm

TTF Lengths 6-10 Single port

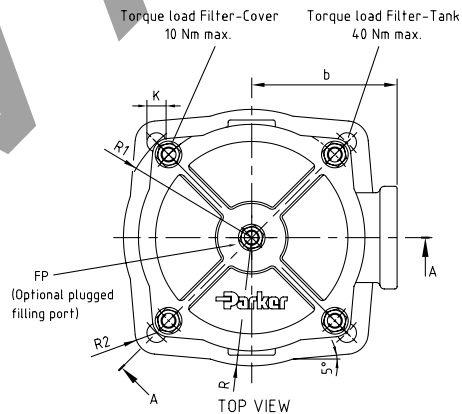
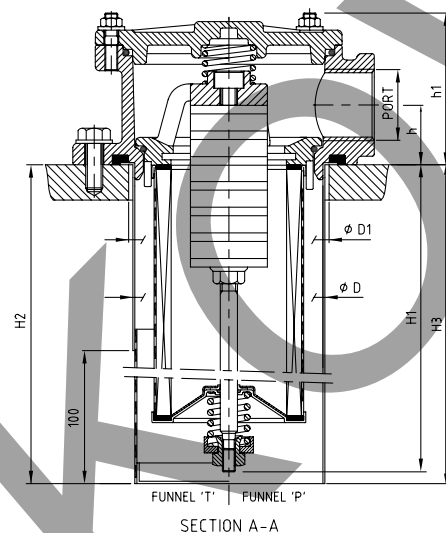

TTF length	Type	Port option	h	h1	ØD	ØD1	H1	H2	H3	b	R	R1	R2	K	FP
6	TTF 2-170	G ¹ / ₄ , G ¹ / ₂	36	92	Ø132	Ø136	223	305	305	90	83	87.5	12	4xØ11	G ³ / ₄
7	TTF 2-230						303	305	305						
8	TTF 2-300						508	510	510						
9	TTF 2-400						523	525	525						
10	TTF 2-500						563	575	575						

Dimensions in mm



TTF Lengths 2-5 Dual port

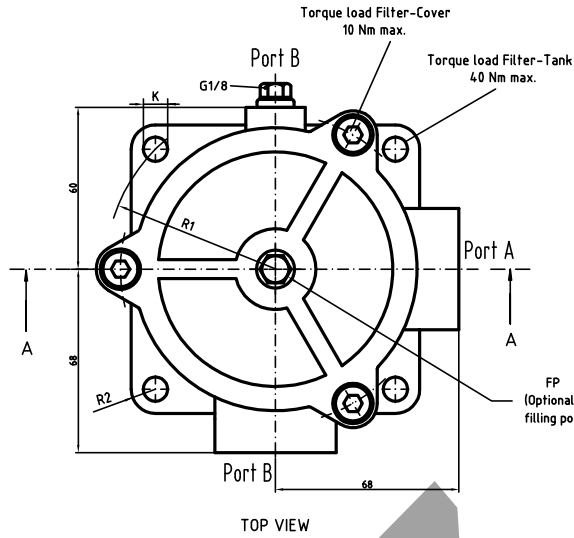
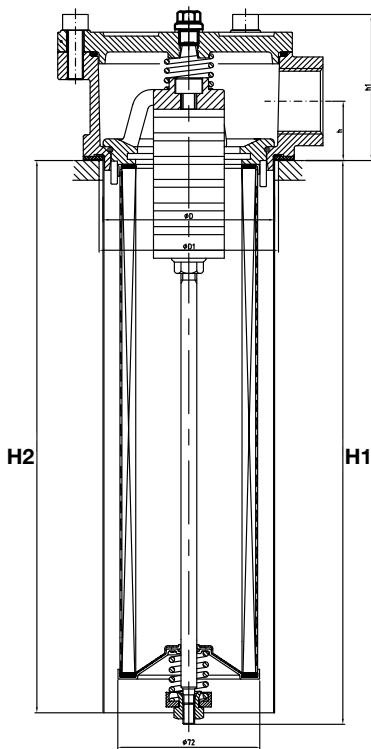

TTF length	Type	Port option A - B	h	h1	∅D	∅D1	H1	H2	b	R	R1	R2	K	FP
2	TTF 1-60	G1 - G1	30	74	∅88	∅91	131	190	90	83	87.5	12	4x∅11	G1/8
3	TTF 1-90						175	170						
4	TTF 1-120						225	220						
4A	TTF 1-140						285	280						
5	TTF 1-150						325	320						
4B	TTF 1-175						376	370						

Dimensions in mm

TTF Lengths 6-10 Dual port

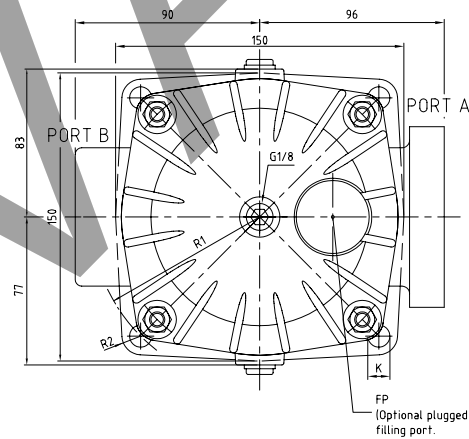
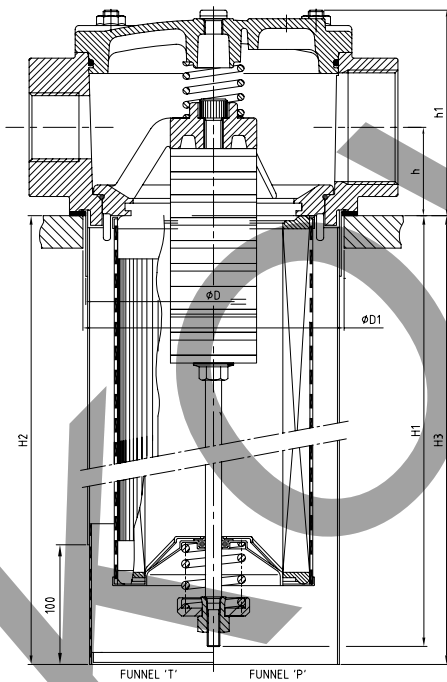

TTF length	Type	Dual Port option A-B	h	h1	∅D	∅D1	H1	H2	H3	R	R1	R2	K	FP
6	TTF 2-170	G1 1/2 - G1 1/2	46	107	∅132	∅136	223	318	318	83	87.5	12	4x∅11	G1
7	TTF 2-230						303	318	318					
8	TTF 2-300						508	538	538					
9**	TTF 2-400	SAE 1 1/2 - G1 1/2					523	538	538					
10**	TTF 2-500						563	578	578					

Dimensions in mm

TTF Series

Tanktop Mounted Return Line Filters

Pressure Drop Curves

The recommended level of the initial pressure drop for low pressure filters is max 0.5 bar.

If the medium used has a viscosity different from 32cSt, pressure drop over the filter can be estimated as follows:

$$\Delta p = (\Delta p_{32} \times \text{viscosity of medium used}) / 32\text{cSt}$$

TTF60 (Element length code 2)

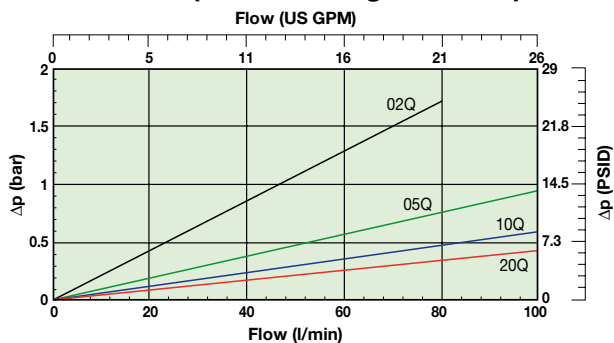

TTF90 (Element length code 3)

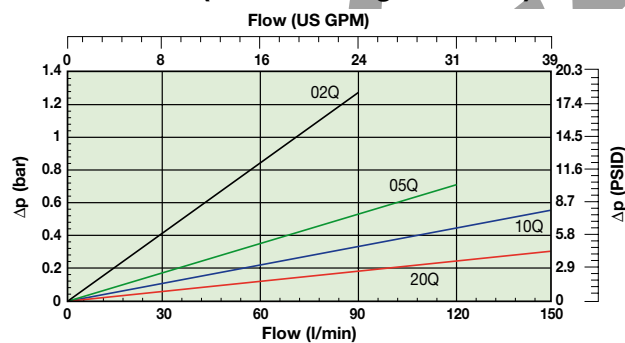

TTF120 (Element length code 4)

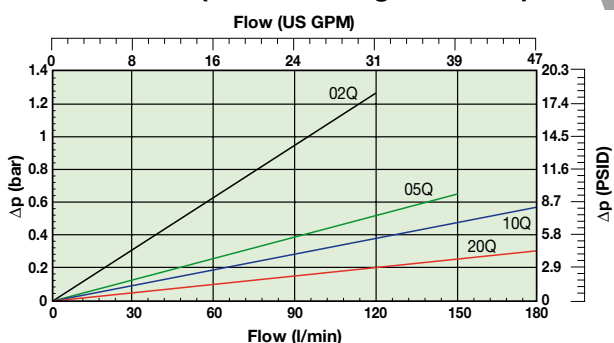

TTF150 (Element length code 5)

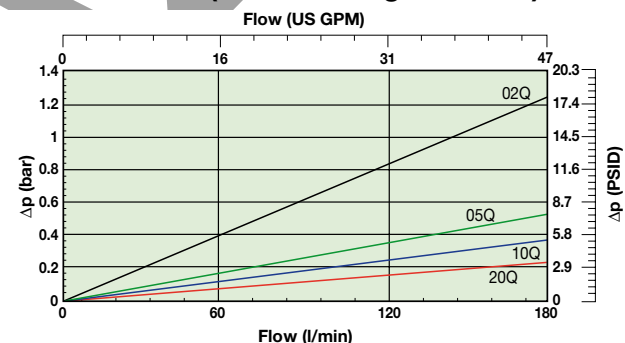

Pressure Drop Curves (cont.)

The recommended level of the initial pressure drop for low pressure filters is max 0.5 bar.

If the medium used has a viscosity different from 32cSt, pressure drop over the filter can be estimated as follows:

$$\Delta p = (\Delta p_{32} \times \text{viscosity of medium used}) / 32\text{cSt}$$

TTF170 (Element length code 6)

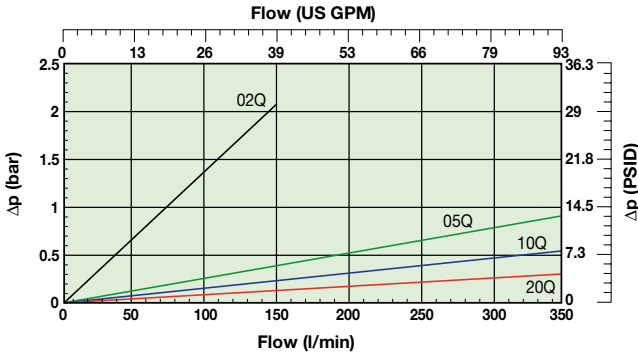

TTF230 (Element length code 7)

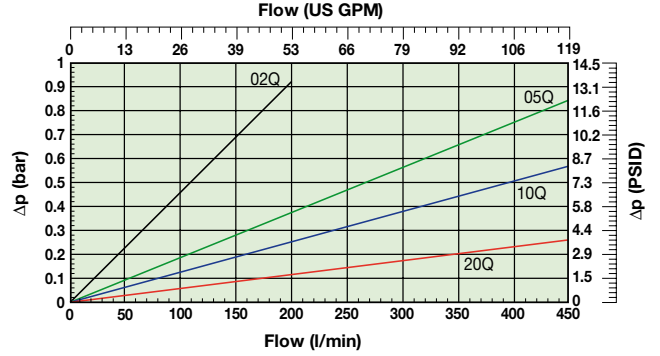

TTF300 (Element length code 8)

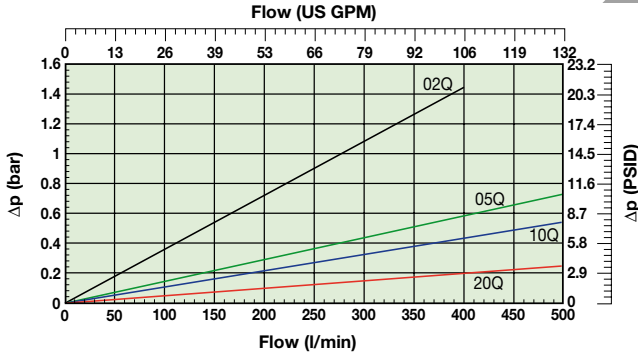

TTF400 (Element length code 9)

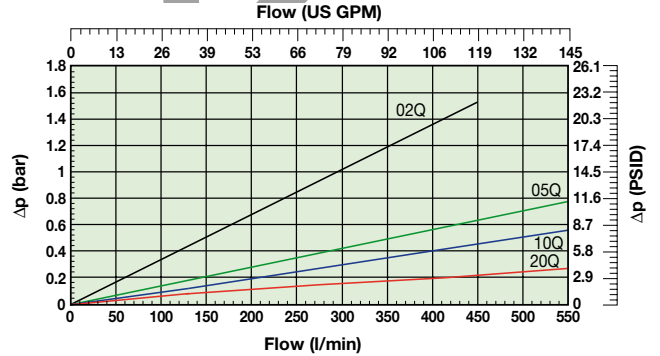

TTF500 (Element length code 10)

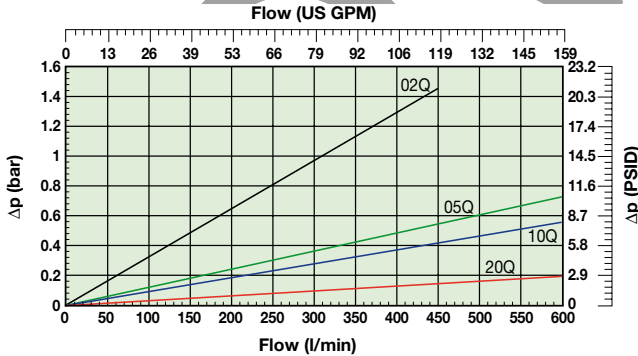

TTF Series

Tanktop Mounted Return Line Filters

Pressure Drop Curves (cont.)

TTF60 (Element length code 2)
Cellulose & stainless steel media

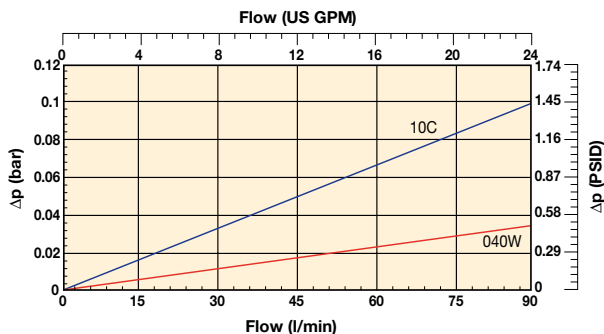

TTF90 (Element length code 3)
Cellulose & stainless steel media

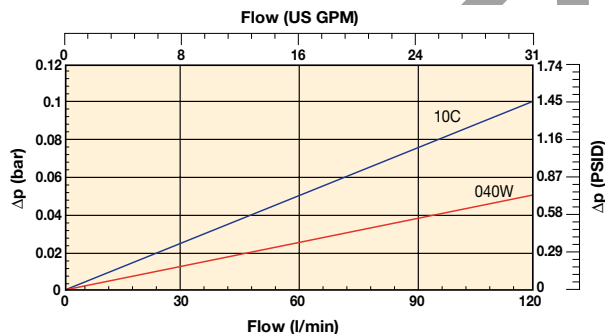

TTF120 (Element length code 4)
Cellulose & stainless steel media

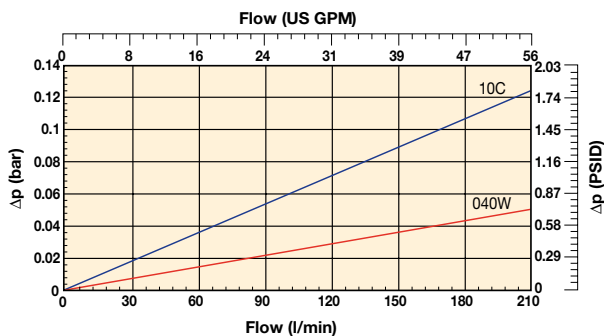

TTF150 (Element length code 5)
Cellulose & stainless steel media

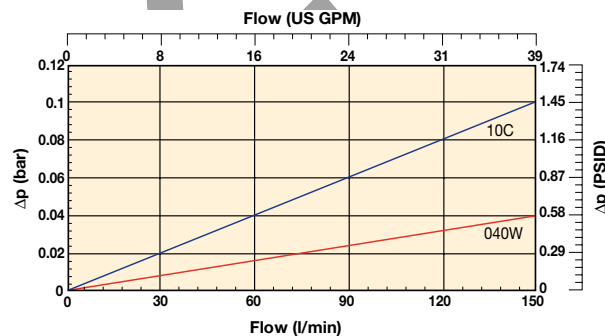

TTF170 (Element length code 6)
Cellulose & stainless steel media

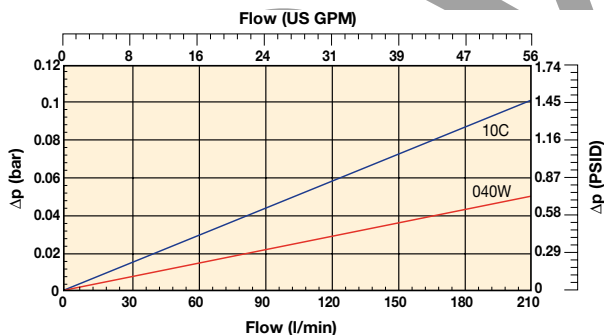

TTF230 (Element length code 7)
Cellulose & stainless steel media

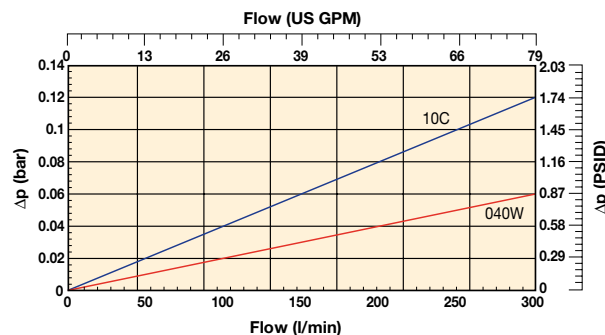

TTF300 (Element length code 8)
Cellulose & stainless steel media

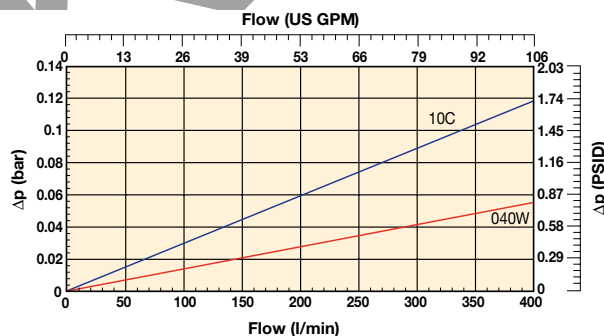

TTF Series

Tanktop Mounted Return Line Filters

Indicator Options

Indicator PS pressure switch

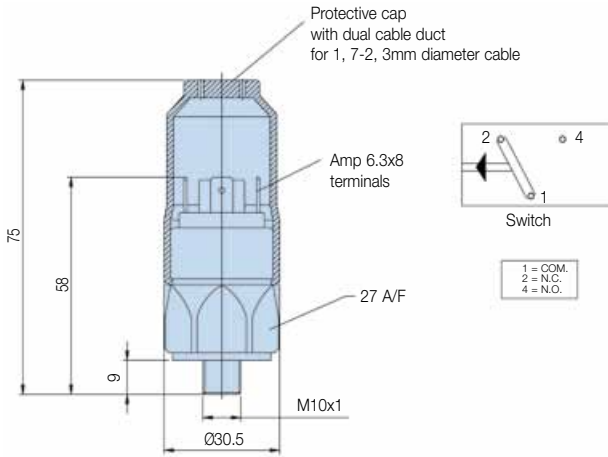

Specifications	
Elec.rating	42V / 4A
Thread connection	M10x1
Elec.connection	AMP 6.3x0.8 terminals + protective cap
Protection	IP65 (with cap) terminals IP00
Code	FMUS1EBMM10L (Switch)

Indicator PS NO/NC pressure switch

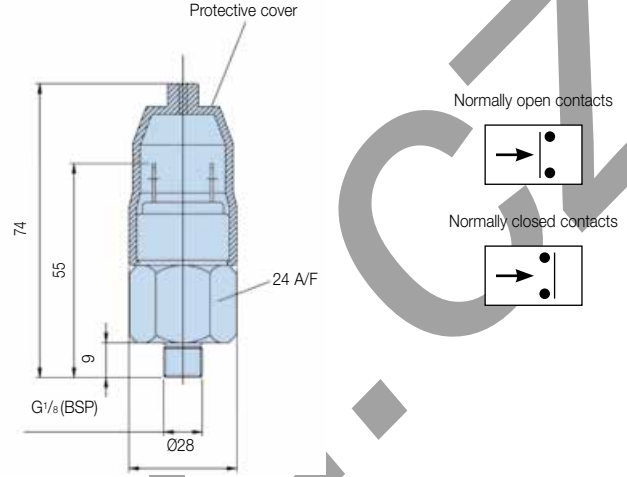

Specifications	
Elec.rating	42V / 2A
Thread connection	G1/8
Elec.connection	AMP terminal 6.3x0.8
Protection	IP65 (terminal IP00)
Switch type	NO or NC
Code	FMUS2EBMG02L (NO switch) FMUS3EBMG02L (NC switch)

Indicator Connection / Filter Head Matrix

Port(s) Filter head	Indicator Thread
TTF ISO 228-G ³ / ₄ " (BSP) (TTF length 2,3,4 and 5)	M10
ISO 228-G1" (BSP)	M10
ISO 228-G1 ¹ / ₂ " (BSP) (TTF length 6 and larger)	M10
2xISO 228-G1 ¹ / ₄ " (BSP) (TTF length 6 and larger)	G1/8"
ISO 228-G1 ¹ / ₂ "(BSP) (TTF length 6 and larger)	M10
2xISO 228-G1 ¹ / ₂ "(BSP) (TTF length 6 and larger)	G1/8"
1 ¹ / ₂ " SAE-3000 PSI (TTF length 6 and larger)	G1/8"
1 ¹ / ₂ " SAE-3000 PSI (2nd port) + G1 ¹ / ₂ " (TTF length 6 and larger)	G1/8"
G2" (TTF length 6 and larger)	G1/8"
G2" + G1 ¹ / ₂ " (TTF length 6 and larger)	G1/8"

Visual indicator	1.2 bar
M10: code	FMUG1EBPM10L
G ¹ / ₈ : code	FMUG2EBPG02L

Ordering Information

Standard products table

Part number	Supersedes	Flow (l/min)	Model number	Element length	Media rating (µ)	Seals	Indicator	Bypass settings	Ports	Included options	Replacement elements	Supersedes
TTF310QLBP2EG121	TTF90-G ³ / ₄ TXWL3-10 B15 MM	90	TTF90	Length 3	10	Nitrile	Plugged	1.5 Bar (22 Psi)	G ³ / ₄	None	937878Q	TXWL3-10
TTF320QLBP2EG121	TTF90-G ³ / ₄ TXWL3-20 B15 MM	90	TTF90	Length 3	20	Nitrile	Plugged	1.5 Bar (22 Psi)	G ³ / ₄	None	937877Q	TXWL3-20
TTF510QLBP2EG161	TTF125-G1 TXWL3E-10 B15 MM	125	TTF125	Length 5	10	Nitrile	Plugged	1.5 Bar (22 Psi)	G1	None	937852Q	TXWL3E-10
TTF520QLBP2EG161	TTF125-G1 TXWL3E-20 B15 MM	125	TTF125	Length 5	20	Nitrile	Plugged	1.5 Bar (22 Psi)	G1	None	937875Q	TXWL3E-20
TTF610QLBP2EG203	TTF170-G1 ¹ / ₄ TXWL4-10 T B15 MM	170	TTF170	Length 6	10	Nitrile	Plugged	1.5 Bar (22 Psi)	G1 ¹ / ₄	Diffuser type T	937853Q	TXWL4-10
TTF620QLBP2EG203	TTF170-G1 ¹ / ₄ TXWL4-20 T B15 MM	170	TTF170	Length 6	20	Nitrile	Plugged	1.5 Bar (22 Psi)	G1 ¹ / ₄	Diffuser type T	937874Q	TXWL4-20
TTF810QLBP2EG243	TTF300-G1 ¹ / ₂ TXWL5A-10 T B15 MM	300	TTF300	Length 8	10	Nitrile	Plugged	1.5 Bar (22 Psi)	G1 ¹ / ₂	Diffuser type T	937855Q	TXWL5A-10
TTF820QLBP2EG243	TTF300-G1 ¹ / ₂ TXWL5A-20 T B15 MM	300	TTF300	Length 8	20	Nitrile	Plugged	1.5 Bar (22 Psi)	G1 ¹ / ₂	Diffuser type T	937872Q	TXWL5A-20
TTF1010QLBP2EG24A	TTF500-G1 ¹ / ₂ TXWL5C-10 T B15 MM NMG	500	TTF500	Length 10	10	Nitrile	Plugged	1.5 Bar (22 Psi)	G1 ¹ / ₂	Diffuser type T	937857Q	TXWL5C-10
TTF1020QLBP2EG24A	TTF500-G1 ¹ / ₂ TXWL5C-20 T B15 MM NMG	500	TTF500	Length 10	20	Nitrile	Plugged	1.5 Bar (22 Psi)	G1 ¹ / ₂	Diffuser type T	937870Q	TXWL5C-20

Note: Filter assemblies ordered from the product configurator on the next page are on extended lead times. Where possible, please make your selection from the table above.

TTF Series

Tanktop Mounted Return Line Filters

Ordering Information (cont.)

Product configurator

Configurator example of a TTF Series filter

Box 1	Box 2	Box 3	Box 4	Box 5	Box 6	Box 7	Box 8
TTF	9	05QL	V	S3	H	L24	1

Box 1	Box 2	Box 3									
Code	Filter type		Degree of filtration								
TTF	Housing	Code	Element media			Glass fibre			Wire mesh		
	TTF 1-60	2				Microglass III (for disposable elements)			Abs. rating		
	TTF 1-90	3				Cellulose				Ecoglass III (for <i>LeiF</i> elements)	
	TTF 1-120	4	Nom. rating								
	TTF 1-140	4A	Disposable element			10C	02Q	05Q	10Q	20Q	040W
	TTF 1-175	4B	LEIF® element			02QL	05QL	10QL	20QL		
	TTF 1-150	5									
	TTF 2-170	6									
	TTF 2-230	7									
	TTF 2-300	8									
	TTF 2-400	9									
	TTF 2-500	10									

Box 4	Seal type	
Seal material	Code	
Nitrile	B	
Fluorelastomer	V	
Neoprene	On request	

Box 5	Indicator	
	Code	
Pressure gauge, setting 1.2 bar, M10x1*	G1	
Pressure gauge, setting 1.2 bar, G $\frac{1}{8}$ for dual head ports	G2	
Pressure switch 42V, 1.2 bar setting, NO/NC, M10x1*	S1	
Pressure switch 42V, 1.2 bar setting, NO with G $\frac{1}{8}$ BSP*	S2	
Pressure switch 42V, 1.2 bar setting, NC with G $\frac{1}{8}$ BSP*	S3	
Pressure switch 250V, NO/NC with G $\frac{1}{8}$ *	S4	
Pressure switch 220V, NO/NC with M10*	S5	
No indicator, indicator ports not machined	On request	
No indicator, indicator ports L + R plugged	P2	
Other settings for indicators / gauges on request	on request	

Box 6	Bypass valve	
Bypass valve	Code	
0.8 bar	B	
1.5 bar	E	
2.0 bar for TTF series	H	
Blocked bypass	X	
Other bypass settings	on request	

Note: * HEAD HAS PLUGGED INDICATOR CONNECTIONS L+R
 Note: Also see the table indicator Connection/Filter Head Matrix on page 29

Box 7	Filter connection	
Ports	Code	
ISO 228-G $\frac{1}{4}$ * (BSP) (TTF length 2,3,4 and 5)	G12	
ISO 228-G1* (BSP) (TTF length 2,3,4 and 5)	G16	
ISO 228-G1 $\frac{1}{4}$ * (BSP) (TTF length 6 and larger)	G20	
ISO 228-G1 $\frac{1}{2}$ * (BSP) (TTF length 6 and larger)	G24	
2xISO 228-G1 $\frac{1}{2}$ * (BSP) (TTF length 6 and larger)	2G24	
1 $\frac{1}{2}$ " SAE-3000 PSI (TTF length 6 and larger)	On request	
1 $\frac{1}{2}$ " SAE-3000 PSI (2nd port) + G1 $\frac{1}{2}$ " (TTF length 6 and larger)	LD24	
G2" (TTF length 6 and larger)	On request	
G2" + G1 $\frac{1}{2}$ " (TTF length 6 and larger)	GM32	

Box 8	Options	
Options	Code	
No diffuser required	1	
Diffuser type T with perforated plate area	3	
Diffuser type P without perforated plate area	4	
Funnel with integrated hose connection for TTF lengths 2, 3 and 4	On request	
No magnets	5	
Plugged filling port	8	
Diffuser type T and no magnets	A	
Diffuser type P and no magnets	B	
Diffuser type T, no magnets, plugged filling port	C	
Diffuser type P, no magnets, plugged filling port	D	
Air tight diffuser type T	G	
Air tight diffuser type P	H	
Other combinations	on request	
ATEX certified* (Category 2, non-electrical equipment)	EX	

Note 1: TTF size 2-400 and 2-500 are standard supplied without magnets.
 Note 2*: For ATEX classified filters add EX after the code.
 For ATEX classified filters with electrical indicator are available on request.
 Visual indicators are classified as Category 2, non electrical equipment.
 Filter assemblies with EX code will be supplied with a dedicated name plate.
 Pls consult Parker Filtration for any questions related to the classification of our products.

Degree of filtration						Media code
Average filtration beta ratio β (ISO 16889) / particle size μm [c]						
$\beta(x)=2$	$\beta(x)=10$	$\beta(x)=75$	$\beta(x)=100$	$\beta(x)=200$	$\beta(x)=1000$	
% efficiency, based on the above beta ratio ($\beta(x)$)						
50.0%	90.0%	98.7%	99.0%	99.5%	99.9%	
N/A	N/A	N/A	N/A	N/A	4.5	02Q/02QL
N/A	N/A	4.5	5	6	7	05Q/05QL
N/A	6	8.5	9	10	12	10Q/10QL
6	11	17	18	20	22	20Q/20QL

Highlights Key (Denotes part number availability)

123	Item is standard
123	Item is standard green option
123	Item is semi standard
123	Item is non standard

Ordering Information (cont.)

Supersedes Spare Element table (TXWL & PXWL replaced by 900000 number)

TTF60	TXWL2-2	TXWL2-5	TXWL2-10	TXWL2-20
Part number spare element	937823Q	937880Q	937881Q	937882Q
TTF90	TXWL3-2	TXWL3-5	TXWL3-10	TXWL3-20
Part number spare element	937824Q	937879Q	937878Q	937877Q
TTF120	TXWL3D-2	TXWL3D-5	TXWL3D-10	TXWL3D-20
Part number spare element	937825Q	937850Q	937851Q	937876Q
TTF150	TXWL3E-2	TXWL3E-5	TXWL3E-10	TXWL3E-20
Part number spare element	937826Q	937849Q	937852Q	937875Q
TTF170	TXWL4-2	TXWL4-5	TXWL4-10	TXWL4-20
Part number spare element	937827Q	937848Q	937853Q	937874Q
TTF230	TXWL5-2	TXWL5-5	TXWL5-10	TXWL5-20
Part number spare element	937828Q	937847Q	937854Q	937873Q
TTF300	TXWL5A-2	TXWL5A-5	TXWL5A-10	TXWL5A-20
Part number spare element	937829Q	937846Q	937855Q	937872Q
TTF400	TXWL5B-2	TXWL5B-5	TXWL5B-10	TXWL5B-20
Part number spare element	937830Q	937845Q	937856Q	937871Q
TTF500	TXWL5C-2	TXWL5C-5	TXWL5C-10	TXWL5C-20
Part number spare element	937831Q	937844Q	937857Q	937870Q

Supersedes Spare Element table (TXW & TXX replaced by 900000 number)

TTF60	TXW2-10-B	TXW2-2-B	TXW2-5-B	TXW2-10-B	TXW2-20-B	ST2-40-B
Part number spare element	937721	937751Q	937754Q	937787Q	937790Q	937820
TTF90	TXW3-10-B	TXW3-2-B	TXW3-5-B	TXW3-10-B	TXW3-20-B	ST3-40-B
Part number spare element	937722	937750Q	937755Q	937786Q	937791Q	937819
TTF120	TXW3D-10-B	TXW3D-2-B	TXW3D-5-B	TXW3D-10-B	TXW3D-20-B	ST3D-40-B
Part number spare element	937723	937749Q	937756Q	937785Q	937792Q	937818
TTF140	FC1260.C010.BS	FC1260.Q002.XS	FC1260.Q005.XS	FC1260.Q010.XS	FC1260.Q020.XS	
Part number spare element	1180309260-01	937977Q	937978Q	937956Q	937957Q	
TTF150	TXW3E-10-B	TXW3E-2-B	TXW3E-5-B	TXW3E-10-B	TXW3E-20-B	ST3E-40-B
Part number spare element	937724	937748Q	937757Q	937784Q	937793Q	937817
TTF170	TXW4-10-B	TXW4-2-B	TXW4-5-B	TXW4-10-B	TXW4-20-B	ST4-40-B
Part number spare element	937725	937747Q	937758Q	937783Q	937794Q	937816
TTF175		FC1275.Q002.XS	FC1275.Q005.XS	FC1275.Q010.XS	FC1260.Q020.XS	
Part number spare element		937979Q	937980Q	937981Q	937982Q	
TTF230	TXW5-10-B	TXW5-2-B	TXW5-5-B	TXW5-10-B	TXW5-20-B	ST5-40-B
Part number spare element	937726	937746Q	937759Q	937782Q	937795Q	937815
TTF300	TXW5A-10-B	TXW5A-2-B	TXW5A-5-B	TXW5A-10-B	TXW5A-20-B	ST5A-40-B
Part number spare element	937727	937745Q	937760Q	937781Q	937796Q	937814

TTF Series Seal Kit

TTF Filter connections	Nitrile Seal Kit
Ports	Part Number
ISO 228-G ³ / ₄ " (BSP) (TTF length 2,3,4 and 5)	2049010012
ISO 228-G1" (BSP) (TTF length 2,3,4 and 5)	2049010012
ISO 228-G1 ¹ / ₂ " (BSP) (TTF length 6 and larger)	2049010013
2xISO 228-G1 ¹ / ₂ " (BSP) (TTF length 6 and larger)	918045035
ISO 228-G1 ¹ / ₂ " (BSP) (TTF length 6 and larger)	2049010013
2xISO 228-G1 ¹ / ₂ " (BSP) (TTF length 6 and larger)	918045035
1 ¹ / ₂ " SAE-3000 PSI (TTF length 6 and larger)	918045035
1 ¹ / ₂ " SAE-3000 PSI (2nd port) + G1 ¹ / ₂ " (TTF length 6 and larger)	918045035
G2" (TTF length 6 and larger)	918045035
G2" + G1 ¹ / ₂ " (TTF length 6 and larger)	918045035

BGT Series

Tanktop Mounted Return Line Filters

Max. 2400 l/min - 10 bar



Patented **LEIF**[®] elements safeguard filtration quality

When high flow performance is needed

The BGT Series features pre-filtration by means of a magnet column and a full flow bypass with low hysteresis. Maximum pressure 10 bar. Maximum flow 2400 l/min. **LEIF**[®] elements available up to 1500 l/min. Designed for a wide range of mobile and industrial applications



Contact Information:

Parker Hannifin
Hydraulic Filter Division Europe

European Product
Information Centre
Freephone: 00800 27 27 5374
(from AT, BE, CH, CZ, DE, EE, ES,
FI, FR, IE, IT, PT, SE, SK, UK)
filtrationinfo@parker.com

www.parker.com/hfde

Product Features:

- BGT features pre-filtration by means of a magnet column.
- Filter heads with multiple ports available.
- Flow from inside to out.
- Full flow bypass with low hysteresis.
- Maximum pressure 10 bar. Maximum flow 2400 l/min.
- Patented **LEIF**[®] elements safeguard filtration quality.

BGT Series

Tanktop Mounted Return Line Filters

Features & Benefits

Features	Advantages	Benefits
10 bar rated filter	Can be utilised for severe return line applications	Reduced downtime due to premature filter failures
Cast aluminium head	Compact profile, lightweight and durable	Less weight, smaller envelop and cleaner appearance
LEIF® elements	Element safeguards the use of genuine parts	Guaranteed quality of filtration Contributes to ISO 14001 certification
Magnetic pre-filtration	Removes ferrous particles, even during bypass conditions	Improved fluid cleanliness levels Extended element life time
In-to-Out filtration	All captured contamination retains inside the element	No recontamination of system during change of elements
High level of customisation	Dedicated system-matched solutions can be easily made available	Improved integration of filter in system combined with lower initial system costs
Quick response bypass with low hysteresis	Reduction of bypass period due to low hysteresis Only a small part of the total flow is bypassing the element	Improved protection of system
Standard or customised funnel	Ensures that oil enters the tank under the oil level	Significant reduction of oil foaming

Typical Applications

- Mobile cranes
- Excavators
- Deck cranes
- Fire fighting equipment
- Hydraulic presses
- Waste balers
- Industrial power units
- Fork lift trucks

The Parker Filtration BGT Series Tank Mounted Return Line Filters.

BGT tanktop mounted return line filters feature pre-filtration by means of a magnet column and a quick response bypass with low hysteresis. Thanks to the 'In-to-Out' filter principle, contaminated oil cannot leak back into the system. BGT Filters are available in versions capable of handling flow rates up to 2400 l/min. They can operate with a maximum working pressure of 10 bar. LEIF® elements are available for environment-friendly filtration for versions up to 1500 l/min.



Specification

Operating pressure:

Max. 10 bar.

Assembly:

Tank top mounted.

Connections:

Flanges SAE2", 3".

Threaded ports and multiple ports available.

Filter housing:

Aluminium head and cover.

Seal material:

Nitrile, fluoroelastomer, neoprene.

Operating temperature range:

Seal material Nitrile: -40° to +100°C.

Seal material Fluoroelastomer: -20° to +120°C.

Bypass setting

Opening pressure 0.8 / 1.5 or 2 bar.

Other settings on request.

Degree of filtration:

Determined by multipass test according to ISO 16889.

Flow fatigue characteristics:

Filter media is supported so that the optimum fatigue life is achieved.

Filtration media:

Microglass III and Ecoglass III for *LEIF*[®] elements.

Also available 10µm Cellulose and 40µm stainless steel mesh.

Element burst rating:

10 bar (ISO 2941).

Pressure indicator options:

Setting 0.7 or 1.2 bar.

Other settings on request.

Visual pressure gauge.

Electrical pressure switch.

Options:

Diffuser type P (straight pipe, no perforated plate area)

Diffuser type T (with closed diffuser end cap and with perforated plate area, recommended when oil entry in reservoir is close to the reservoir bottom or to ensure oil entry under the reservoir oil level)

Magnetic pack:

Standard.

Filling port in cover (optional):

BGT 3 = Plugged G1¹/₄. BGT 4 = Plugged G1¹/₂.

Filter element:

LEIF[®] element with reusable metal element sleeve.

Conventional style element with steel end caps.

The *LEIF*[®] element is patented and safeguards the use of genuine parts.

Note:

LEIF[®] element can be used with mineral and HEES type oils.

For other fluids consult Parker Filtration.

LEIF[®] contributes to ISO 14001 quality standards.

BGT-3 Length 11 and 12 (<i>LEIF</i> [®] version)		
Ref.	No.	Description
1	1	Nut
2	1	Washer
3	1	Cover
4	1	Cover-seal
5	1	Top-spring
6	1	Housing
7	1	Insert-seal
8	1	Plug M10x1
9	1	Bonded seal
10	1	Insert
11	1	<i>LEIF</i> [®] element
12	1	Element sleeve
13	1	Gasket
14	1	O-ring
15	1	Bypass set
16	1	Diffuser

BGT-4 Length 13 and larger (conventional element)		
Ref.	No.	Description
1	1	Nut
2	1	Washer
3	1	Cover
4	1	Cover-seal
5	1	Top-spring
6	1	Housing
7	1	Insert-seal
8	1	Plug M10x1
9	1	Bonded seal
10	1	Insert
11	1	Element seal
12	1	Element
13	1	O-ring
14	1	O-ring
15	1	Bypass set
16	1	Diffuser

BGT-3 (*LEIF*[®] version)

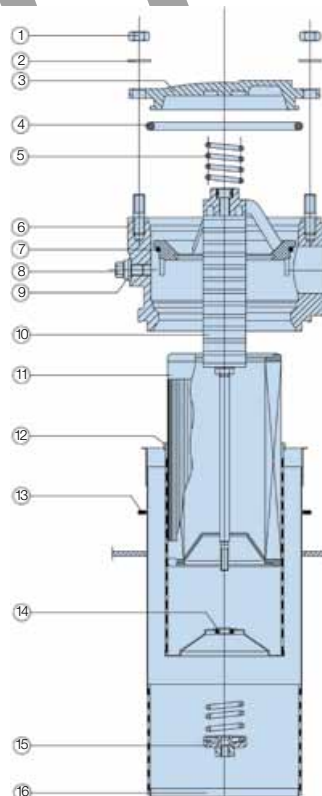

BGT-4 (conventional element)

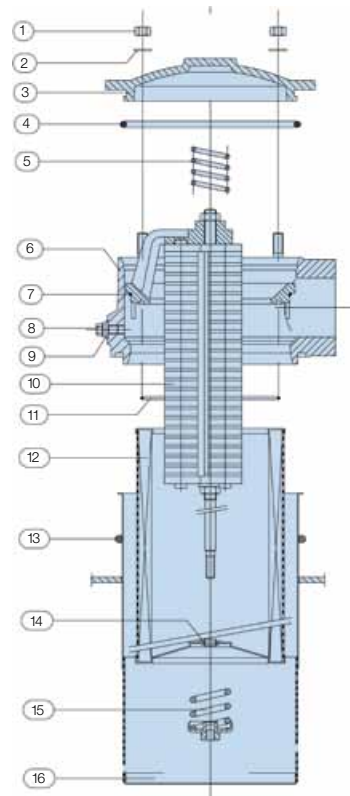

BGT Series

Tanktop Mounted Return Line Filters

Specification (cont.)

BGT-3 with diffuser

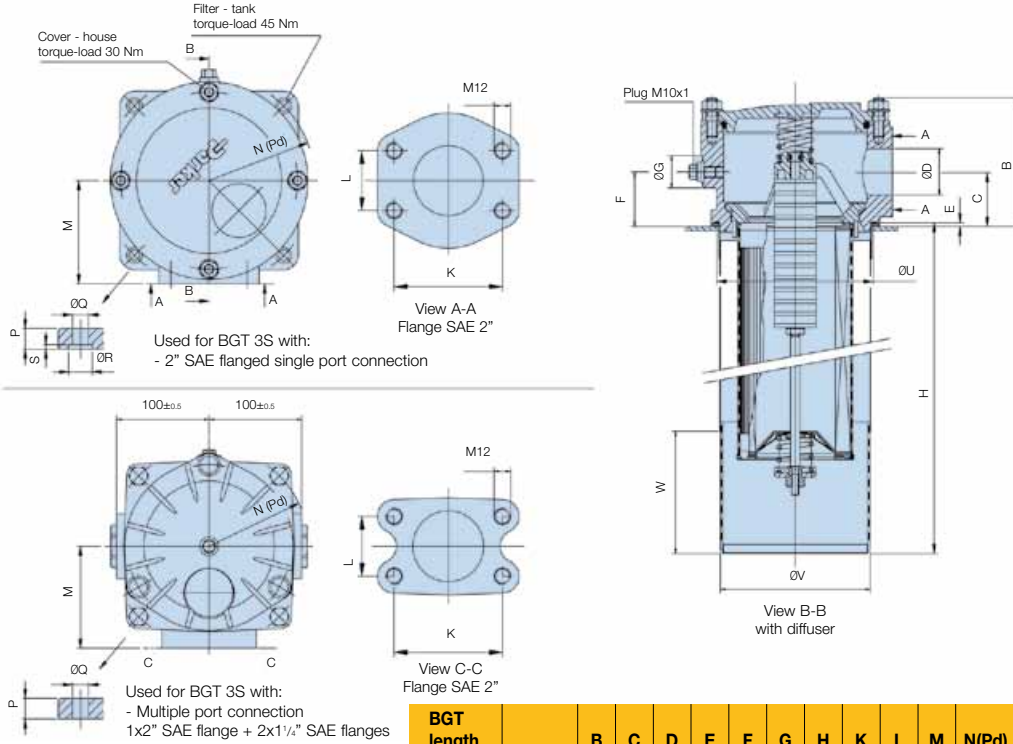

Dimensions in mm

BGT length		B	C	D	E	F	G	H	K	L	M	N(Pd)	P	Q	R	S	U	V	W	Kg.
11	BGT390	139	59	50	3	59	35	350	78	43	105	R107.5	14	13	16	3	165.5 ^{+0.5} ₀	165	120	7.2
12	BGT500							540												8.6
Multiple port connection		(131)	(55)			(55)					(110)		(15)				(166 ^{+0.5} ₀)			

BGT-3 without diffuser

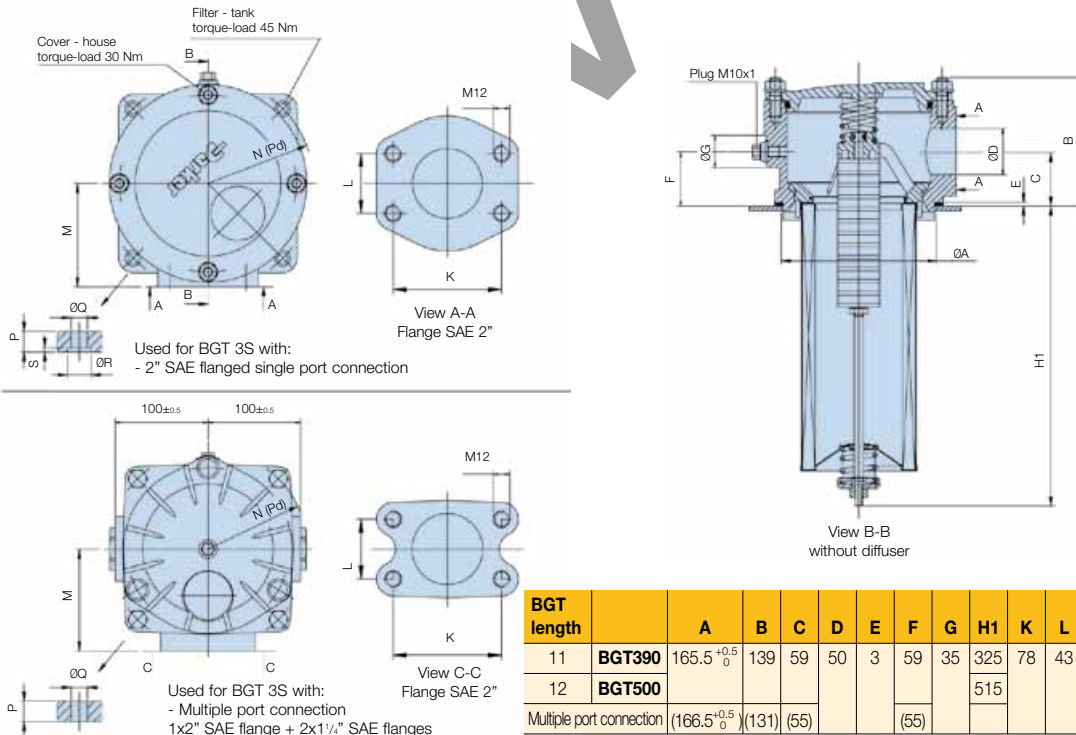

Dimensions in mm

BGT length		A	B	C	D	E	F	G	H1	K	L	M	N(Pd)	P	Q	R	S	Kg.
11	BGT390	165.5 ^{+0.5} ₀	139	59	50	3	59	35	325	78	43	105	R107.5	14	13	16	3	7.2
12	BGT500								515									8.6
Multiple port connection		(166.5 ^{+0.5} ₀)	(131)	(55)			(55)					(110)		(15)				

BGT-4 with diffuser

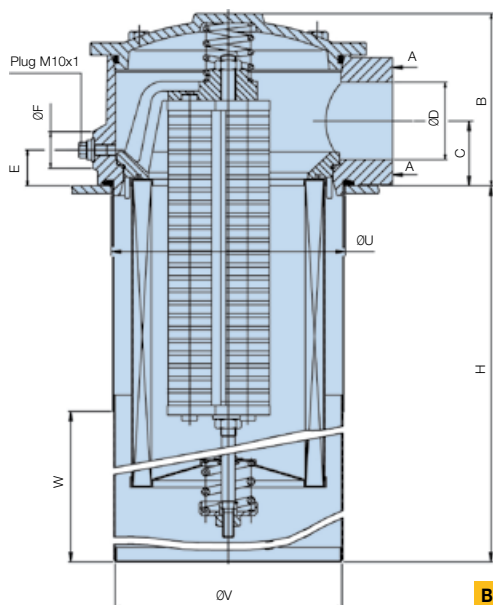

View B-B with diffuser

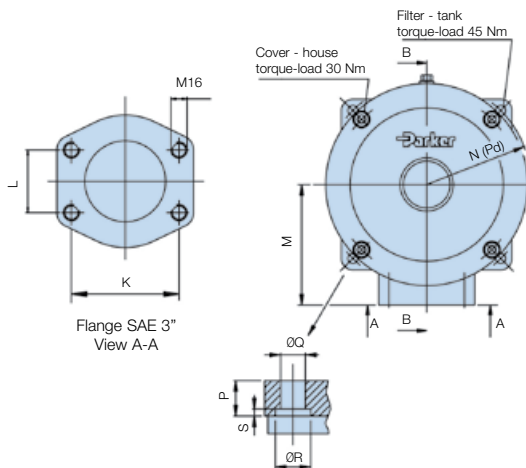

BGT length		B	C	ØD	E	ØF	H	K	L	M	N(Pd)	P	ØQ	ØR	S	ØU	ØV	W	Kg.
13	BGT600						425												20.5
14	BGT800						535												23.0
15	BGT1000	178	67	80	37	40	640	106.4	62	170	R147.5	20	14	20	4	240.5 ^{+0.5} ₀	240	170	25.5
16	BGT1500						920												30.0
17	BGT2000						1200												37.0
18	BGT2400						1200												37.0

Note: dimensions of BGT-2400 identical to BGT-2000. Dimensions in mm

BGT-4 without diffuser

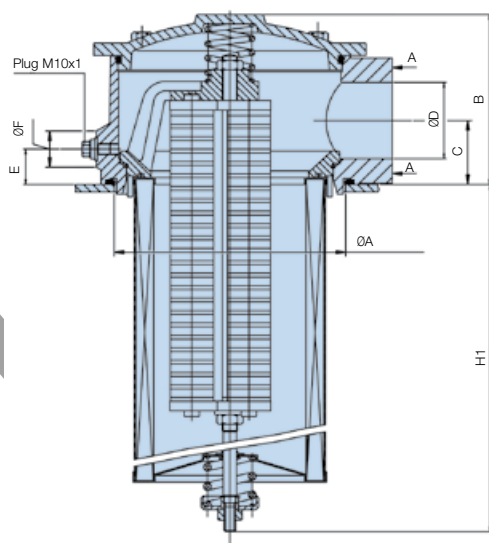

View B-B without diffuser

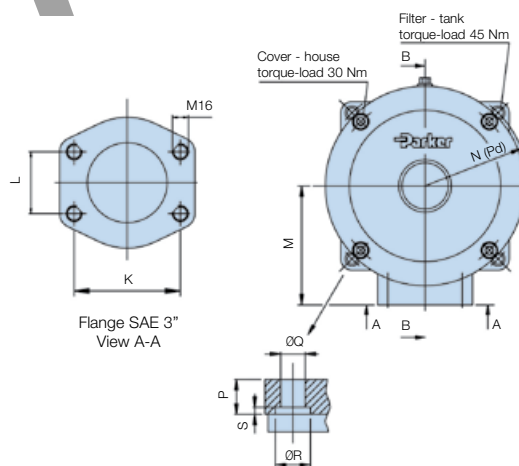

BGT length		ØA	B	C	ØD	E	ØF	H1	K	L	M	N(Pd)	P	ØQ	ØR	S	Kg.
13	BGT600							385									20.5
14	BGT800							495									23.0
15	BGT1000	239.5 ^{+0.5} ₀	178	67	80	37	40	598	106.4	62	170	R147.5	20	14	20	4	25.5
16	BGT1500							878									30.0
17	BGT2000							1143									37.0
18	BGT2400							1143									37.0

Note: dimensions of BGT-2400 identical to BGT-2000. Dimensions in mm



BGT Series

Tanktop Mounted Return Line Filters

Specification (cont.)

BGT F1¹/₄ manifold type - with diffuser

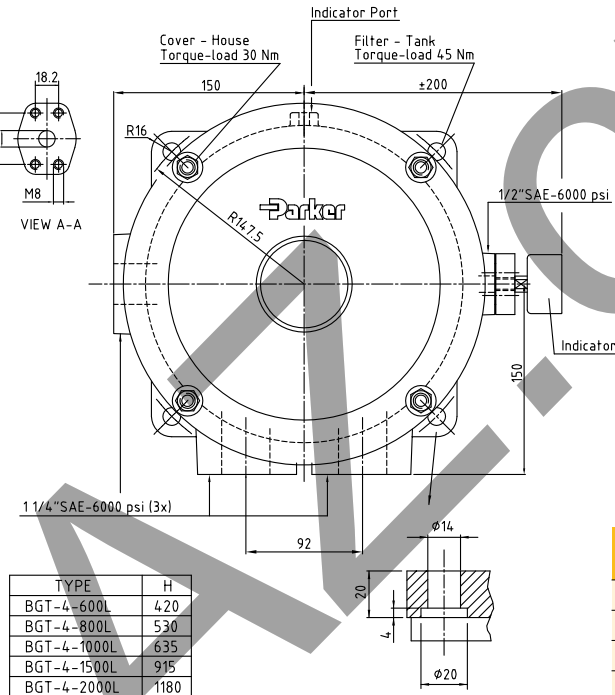
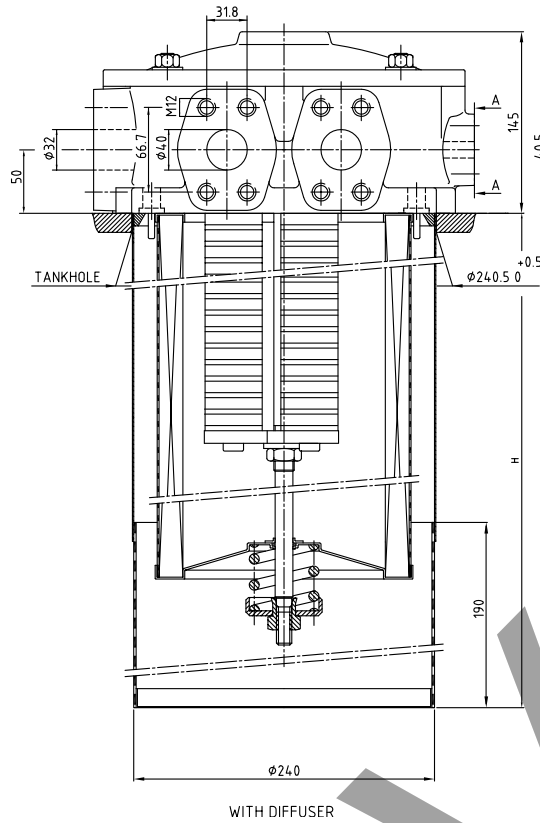

TYPE	H
BGT-4-600L	420
BGT-4-800L	530
BGT-4-1000L	635
BGT-4-1500L	915
BGT-4-2000L	1180

BGT length		H
13	BGT600L	420
14	BGT800L	530
15	BGT1000L	636
16	BGT1500L	915
17	BGT2000L	1180
18	BGT2400L	1180

Dimensions in mm

BGT F1¹/₄ manifold type - without diffuser

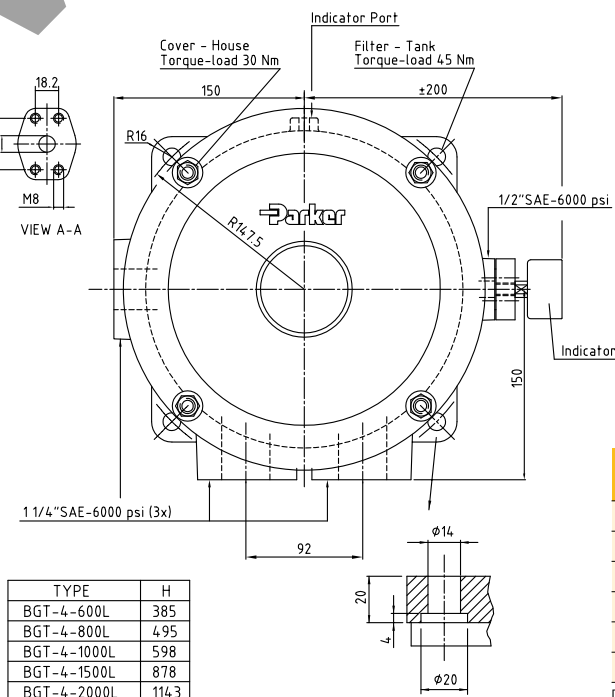
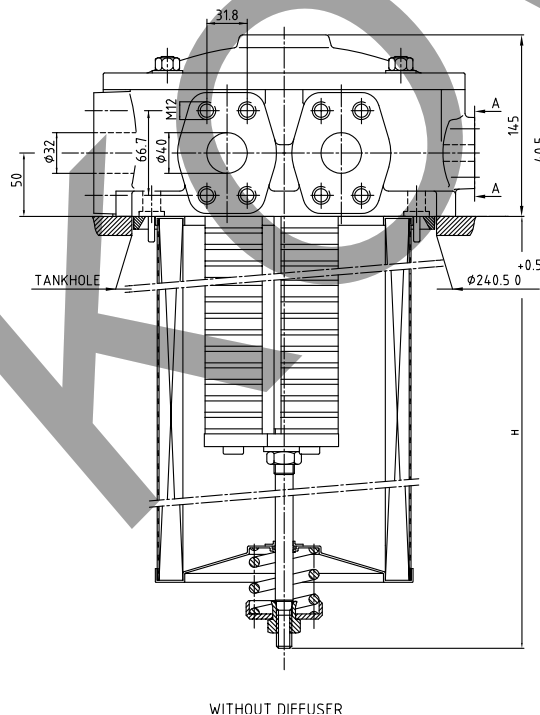

TYPE	H
BGT-4-600L	385
BGT-4-800L	495
BGT-4-1000L	598
BGT-4-1500L	878
BGT-4-2000L	1143

BGT length		H
13	BGT600L	385
14	BGT800L	495
15	BGT1000L	598
16	BGT1500L	878
17	BGT2000L	1143
18	BGT2400L	1143

Dimensions in mm



Indicator Options

Indicator PS pressure switch

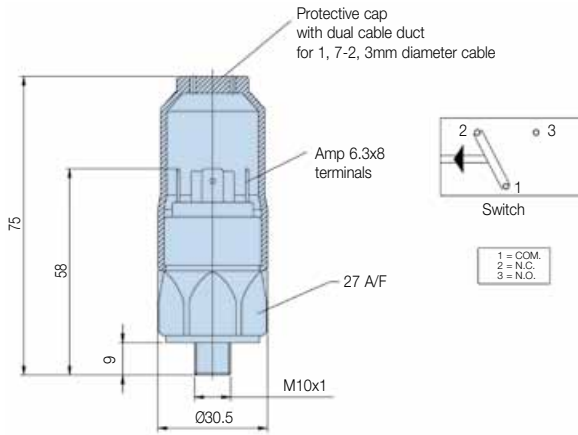

Specifications	
Elec.rating	42V / 4A
Thread connection	M10x1
Elec.connection	AMP 6.3x0.8 terminals + protective cap
Protection	IP65 (with cap) terminals IP00
Code	FMUS1EBMM10L (Switch)

Indicator Connection / Filter Head Matrix	
Port(s) Filter head	Indicator Thread
2" SAE BGT length 11 and 12	M10
3" SAE BGT Length 13 and larger	M10
1x2"SAE Flanged + 2 x 1 1/4" SAE Flanged for BGT Length 11 and 12	G1/8"
3x1 1/4" SAE Flanges + 1x 1/2" SAE for BGT Length 13 and larger	G1/8"

Indicator PS NO/NC pressure switch

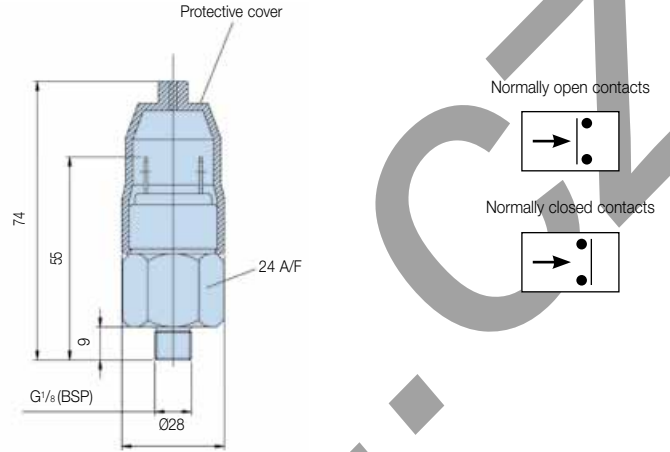

Specifications	
Elec.rating	42V / 2A
Thread connection	G1/8
Elec.connection	AMP terminal 6.3x0.8
Protection	IP65 (terminal IP00)
Switch type	NO or NC
Code	FMUS2EBMG02L (NO switch) FMUS3EBMG02L (NC switch)

Visual indicator	1.2 bar
M10 code	FMUG1EBPM10L
G1/8 code	FMUG2EBPG02L

Pressure Drop Curves

The recommended level of the initial pressure drop for low pressure filters is max 0.5 bar.

If the medium used has a viscosity different from 32cSt, pressure drop over the filter can be estimated as follows:

$$\Delta p = (\Delta p_{32} \times \text{viscosity of medium used}) / 32\text{cSt}$$

Filter housing and element pressure drop based on 32cSt fluid viscosity and 0.87 density.

BGT Empty Housing 2"SAE (Length code 11 and 12)

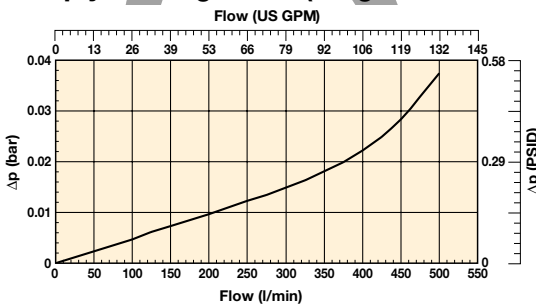

BGT390 (Element length code 11)

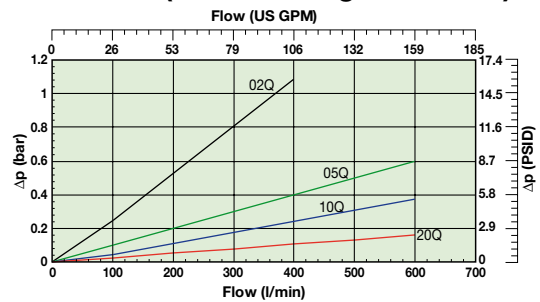

BGT500 (Element length code 12)

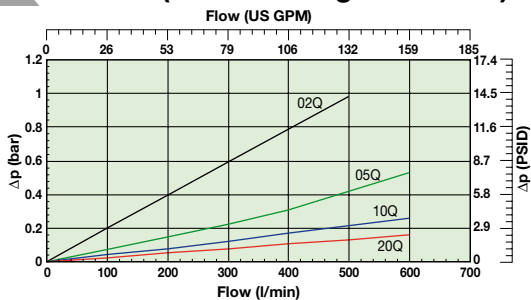

BGT Series

Tanktop Mounted Return Line Filters

Pressure Drop Curves (cont.)

BGT Empty Housing 3"SAE (Length 13 and larger)

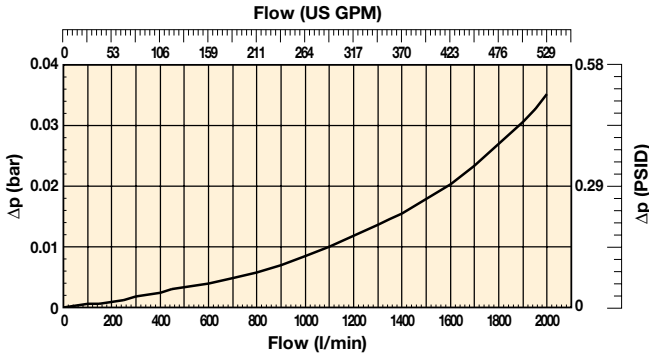

BGT600 (Element length code 13)

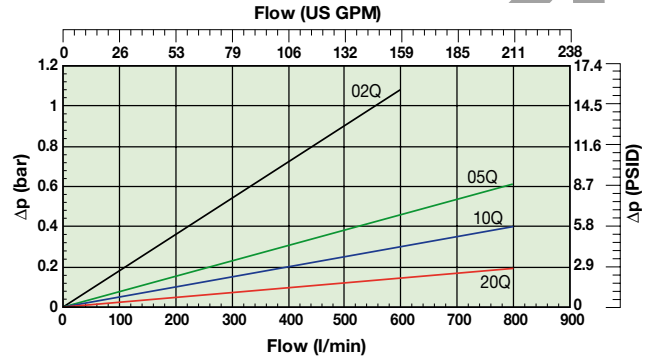

BGT800 (Element length code 14)

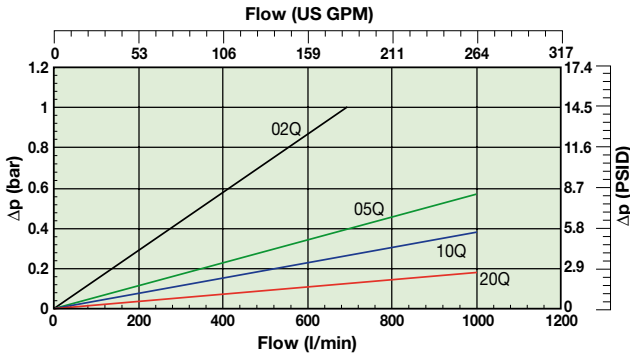

BGT1000 (Element length code 15)

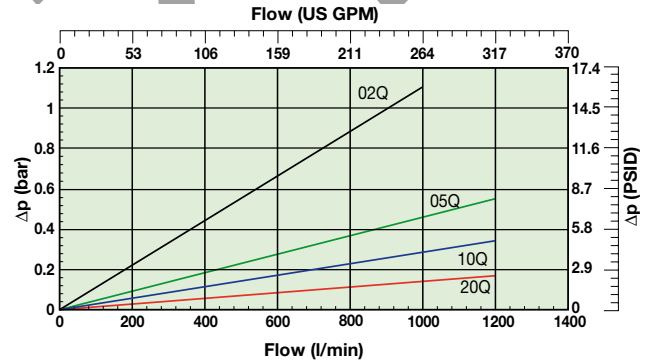

BGT1500 (Element length code 16)

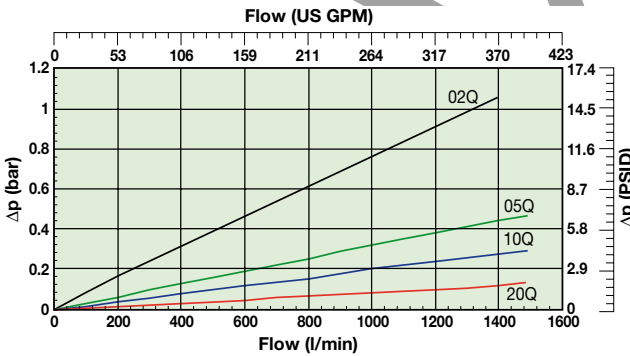

BGT2000 (Element length code 17)

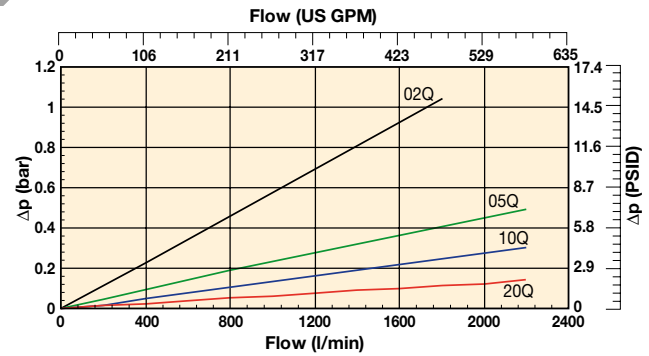

BGT2400 (Element length code 18)

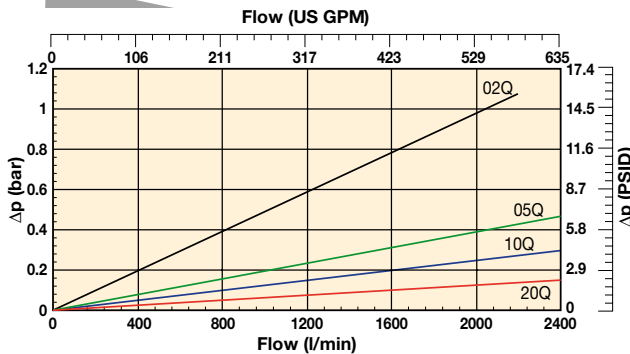

Pressure Drop Curves (cellulose and stainless steel media)

**BGT390 (Element length code 11)
Cellulose & Stainless steel media**

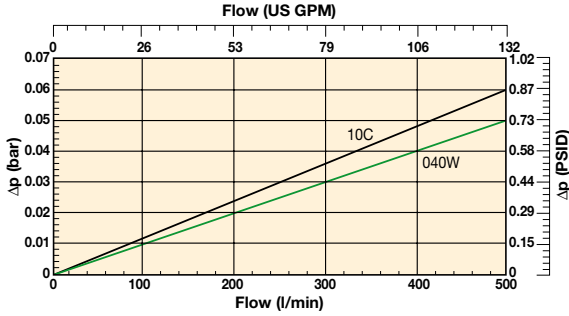

**BGT390 (Element length code 11)
Cellulose & Stainless steel media**

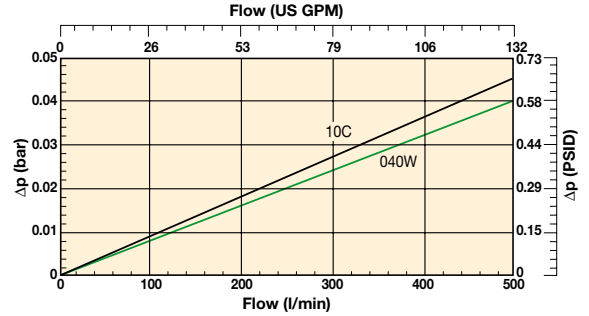

**BGT600 (Element length code 13)
Cellulose & Stainless steel media**

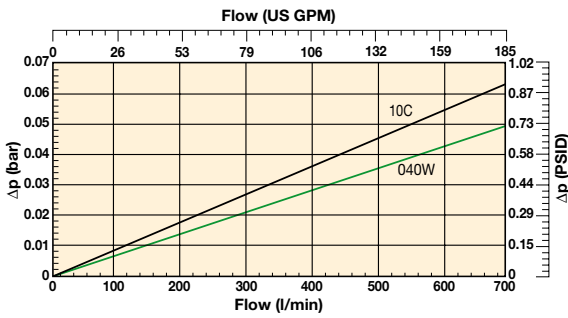

**BGT800 (Element length code 14)
Cellulose & Stainless steel media**

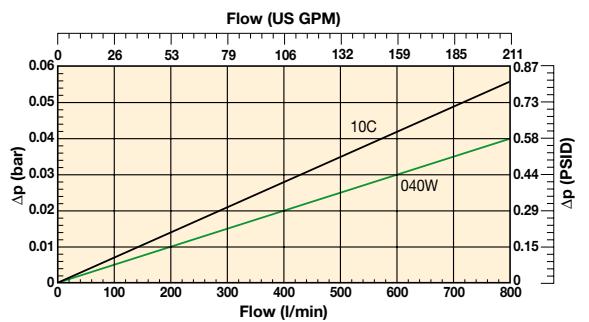

**BGT1000 (Element length code 15)
Cellulose & Stainless steel media**

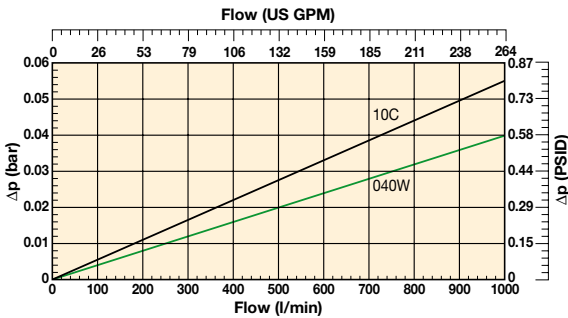

**BGT1500 (Element length code 16)
Cellulose & Stainless steel media**

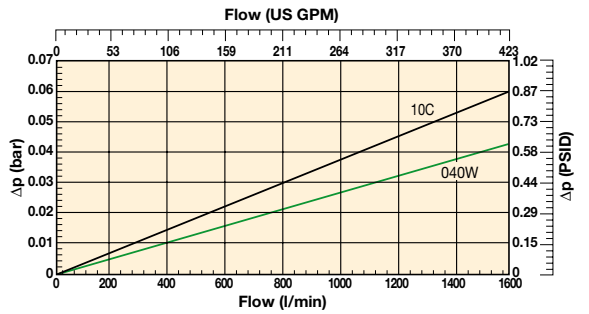

**BGT2000 (Element length code 17)
Cellulose & Stainless steel media**

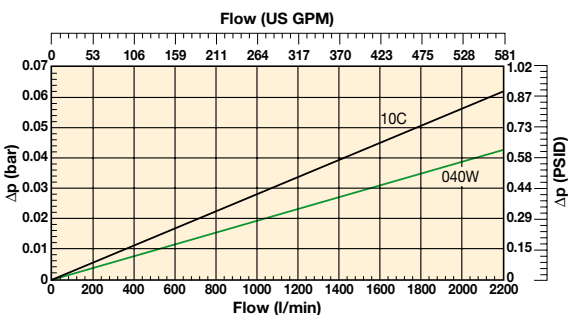

Cellulose and stainless steel media
Example: BGT2000 Filter Element Length 17 - cellulose and stainless steel media



BGT Series

Tanktop Mounted Return Line Filters

Ordering Information

Standard products table

Part number	Supersedes	Flow (l/min)	Model number	Element length	Media rating (µ)	Seals	Indicator	Bypass settings	Ports	Included options	Replacement elements	Supersedes
BGT1210QLBPER323	BGTS500-S2 TXWL8C-10 T B15 M	500	BGT500	Length 12	10	Nitrile	Plugged	1.5 Bar (22 Psi)	2"SAE-3000 PSI	Diffuser type T	937859Q	TXWL8L-10
BGT1220QLBPER323	BGTS500-S2 TXWL8C-20 T B15 M	500	BGT500	Length 12	20	Nitrile	Plugged	1.5 Bar (22 Psi)	2"SAE-3000 PSI	Diffuser type T	937868Q	TXWL8L-20
BGT1510QLBPER483	BGTS1000-S3 TXWL12-10 T B15 M	1000	BGT1000	Length 15	10	Nitrile	Plugged	1.5 Bar (22 Psi)	3"SAE-3000 PSI	Diffuser type T	937862Q	TXWL12-10
BGT1520QLBPER483	BGTS1000-S3 TXWL12-20 T B15 M	1000	BGT1000	Length 15	20	Nitrile	Plugged	1.5 Bar (22 Psi)	3"SAE-3000 PSI	Diffuser type T	937865Q	TXWL12-20
BGT1710QBPER483	BGTS2000-S3 TXW14-10 T B15 M	2000	BGT2000	Length 17	10	Nitrile	Plugged	1.5 Bar (22 Psi)	3"SAE-3000 PSI	Diffuser type T	937772Q	TXW14-10B
BGT1720QBPER483	BGTS2000-S3 TXW14-20 T B15 M	2000	BGT2000	Length 17	20	Nitrile	Plugged	1.5 Bar (22 Psi)	3"SAE-3000 PSI	Diffuser type T	937805Q	TXW14-20B

Note: Filter assemblies ordered from the product configurator below are on extended lead times. Where possible, please make your selection from the table above.

Product configurator

Configurator examples filter including LEIF® element

Box 1	Box 2	Box 3	Box 4	Box 5	Box 6	Box 7	Box 8
BGT	15	05QL	B	S1	E	R48	C

Configurator examples filter including conventional element

Box 1	Box 2	Box 3	Box 4	Box 5	Box 6	Box 7	Box 8
BGT	18	02Q	B	S4	E	3R20	4

Code	Filter type	Degree of filtration							
BGT	Housing	Element media							
	BGT390	Code	Glass fibre			Wire mesh			
	BGT500	11	Microglass III (for disposable elements)						
	BGT600	12	Cellulose						
	BGT800	13	Ecoglass III (for LEIF® elements)						
	BGT1000	14	Nom. rating			Abs. rating			
	BGT1500	15	10C	02Q	05Q	10Q	20Q		
	BGT2000	16	LEIF® element			02QL	05QL	10QL	20QL
	BGT2400	17							
	BGT2400	18							

Box 4	Box 5	Box 6																																										
Seal type	Indicator	Bypass valve																																										
<table border="1"> <thead> <tr> <th>Seal material</th> <th>Code</th> </tr> </thead> <tbody> <tr> <td>Nitrile</td> <td>B</td> </tr> <tr> <td>Fluorelastomer</td> <td>V</td> </tr> <tr> <td>Neoprene</td> <td>on request</td> </tr> </tbody> </table>	Seal material	Code	Nitrile	B	Fluorelastomer	V	Neoprene	on request	<table border="1"> <thead> <tr> <th></th> <th>Code</th> </tr> </thead> <tbody> <tr> <td>Pressure gauge, setting 1.2 bar, M10x1</td> <td>G1</td> </tr> <tr> <td>Pressure gauge, setting 1.2 bar, G1/4 for dual port head</td> <td>G2</td> </tr> <tr> <td>Pressure switch 42V, 1.2 bar setting, NO/NC, M10x1</td> <td>S1</td> </tr> <tr> <td>Pressure switch 42V, 1.2 bar setting, NO with G1/8 BSP</td> <td>S2</td> </tr> <tr> <td>Pressure switch 42V, 1.2 bar setting, NC with G1/8 BSP</td> <td>S3</td> </tr> <tr> <td>Pressure switch 250V, NO/NC with G1/8</td> <td>S4</td> </tr> <tr> <td>Pressure switch 220V, NO/NC with M10</td> <td>S5</td> </tr> <tr> <td>No indicator, indicator ports not machined</td> <td>On request</td> </tr> <tr> <td>No indicator, indicator port B plugged</td> <td>P</td> </tr> <tr> <td>Other settings for indicators / gauges on request</td> <td>on request</td> </tr> </tbody> </table>		Code	Pressure gauge, setting 1.2 bar, M10x1	G1	Pressure gauge, setting 1.2 bar, G1/4 for dual port head	G2	Pressure switch 42V, 1.2 bar setting, NO/NC, M10x1	S1	Pressure switch 42V, 1.2 bar setting, NO with G1/8 BSP	S2	Pressure switch 42V, 1.2 bar setting, NC with G1/8 BSP	S3	Pressure switch 250V, NO/NC with G1/8	S4	Pressure switch 220V, NO/NC with M10	S5	No indicator, indicator ports not machined	On request	No indicator, indicator port B plugged	P	Other settings for indicators / gauges on request	on request	<table border="1"> <thead> <tr> <th>Bypass valve</th> <th>Code</th> </tr> </thead> <tbody> <tr> <td>0.8 bar</td> <td>B</td> </tr> <tr> <td>1.5 bar</td> <td>E</td> </tr> <tr> <td>2.0 bar for BGT-3 series (length 11 and 12)</td> <td>H</td> </tr> <tr> <td>Blocked bypass</td> <td>X</td> </tr> <tr> <td>Other bypass settings</td> <td>on request</td> </tr> </tbody> </table>	Bypass valve	Code	0.8 bar	B	1.5 bar	E	2.0 bar for BGT-3 series (length 11 and 12)	H	Blocked bypass	X	Other bypass settings	on request
Seal material	Code																																											
Nitrile	B																																											
Fluorelastomer	V																																											
Neoprene	on request																																											
	Code																																											
Pressure gauge, setting 1.2 bar, M10x1	G1																																											
Pressure gauge, setting 1.2 bar, G1/4 for dual port head	G2																																											
Pressure switch 42V, 1.2 bar setting, NO/NC, M10x1	S1																																											
Pressure switch 42V, 1.2 bar setting, NO with G1/8 BSP	S2																																											
Pressure switch 42V, 1.2 bar setting, NC with G1/8 BSP	S3																																											
Pressure switch 250V, NO/NC with G1/8	S4																																											
Pressure switch 220V, NO/NC with M10	S5																																											
No indicator, indicator ports not machined	On request																																											
No indicator, indicator port B plugged	P																																											
Other settings for indicators / gauges on request	on request																																											
Bypass valve	Code																																											
0.8 bar	B																																											
1.5 bar	E																																											
2.0 bar for BGT-3 series (length 11 and 12)	H																																											
Blocked bypass	X																																											
Other bypass settings	on request																																											

Note: For all dual head ports for BGTS apply G1/4 connection for indicators

Box 7	Box 8																																										
Filter connection	Options																																										
<table border="1"> <thead> <tr> <th>Ports</th> <th>Code</th> </tr> </thead> <tbody> <tr> <td>2" SAE BGT length 11 and 12</td> <td>R32</td> </tr> <tr> <td>3" SAE BGT Length 13 and larger</td> <td>R48</td> </tr> <tr> <td>1x2" SAE Flanged + 2 x 1 1/2" SAE Flanged for BGT Length 11 and 12</td> <td>R32M</td> </tr> <tr> <td>3x1 1/2" SAE Flanges + 1x 1/2" SAE for BGT Length 13 and larger</td> <td>3R20</td> </tr> </tbody> </table>	Ports	Code	2" SAE BGT length 11 and 12	R32	3" SAE BGT Length 13 and larger	R48	1x2" SAE Flanged + 2 x 1 1/2" SAE Flanged for BGT Length 11 and 12	R32M	3x1 1/2" SAE Flanges + 1x 1/2" SAE for BGT Length 13 and larger	3R20	<table border="1"> <thead> <tr> <th>Options</th> <th>Code</th> </tr> </thead> <tbody> <tr> <td>No diffuser required</td> <td>1</td> </tr> <tr> <td>Diffuser type T with perforated plate area</td> <td>3</td> </tr> <tr> <td>Diffuser type P without perforated plate area</td> <td>4</td> </tr> <tr> <td>No magnets</td> <td>5</td> </tr> <tr> <td>Plugged filling port</td> <td>8</td> </tr> <tr> <td>Diffuser type T and no magnets</td> <td>A</td> </tr> <tr> <td>Diffuser type P and no magnets</td> <td>B</td> </tr> <tr> <td>Diffuser type T, no magnets, plugged filling port</td> <td>C</td> </tr> <tr> <td>Diffuser type P, no magnets, plugged filling port</td> <td>D</td> </tr> <tr> <td>Diffuser type T, magnets and filling port</td> <td>E</td> </tr> <tr> <td>Diffuser type P, magnets and filling port</td> <td>F</td> </tr> <tr> <td>Air tight diffuser type T</td> <td>G</td> </tr> <tr> <td>Air tight diffuser type P</td> <td>H</td> </tr> <tr> <td>Other combinations</td> <td>on request</td> </tr> <tr> <td>ATEX certified* (Category 2, non-electrical equipment)</td> <td>EX</td> </tr> </tbody> </table>	Options	Code	No diffuser required	1	Diffuser type T with perforated plate area	3	Diffuser type P without perforated plate area	4	No magnets	5	Plugged filling port	8	Diffuser type T and no magnets	A	Diffuser type P and no magnets	B	Diffuser type T, no magnets, plugged filling port	C	Diffuser type P, no magnets, plugged filling port	D	Diffuser type T, magnets and filling port	E	Diffuser type P, magnets and filling port	F	Air tight diffuser type T	G	Air tight diffuser type P	H	Other combinations	on request	ATEX certified* (Category 2, non-electrical equipment)	EX
Ports	Code																																										
2" SAE BGT length 11 and 12	R32																																										
3" SAE BGT Length 13 and larger	R48																																										
1x2" SAE Flanged + 2 x 1 1/2" SAE Flanged for BGT Length 11 and 12	R32M																																										
3x1 1/2" SAE Flanges + 1x 1/2" SAE for BGT Length 13 and larger	3R20																																										
Options	Code																																										
No diffuser required	1																																										
Diffuser type T with perforated plate area	3																																										
Diffuser type P without perforated plate area	4																																										
No magnets	5																																										
Plugged filling port	8																																										
Diffuser type T and no magnets	A																																										
Diffuser type P and no magnets	B																																										
Diffuser type T, no magnets, plugged filling port	C																																										
Diffuser type P, no magnets, plugged filling port	D																																										
Diffuser type T, magnets and filling port	E																																										
Diffuser type P, magnets and filling port	F																																										
Air tight diffuser type T	G																																										
Air tight diffuser type P	H																																										
Other combinations	on request																																										
ATEX certified* (Category 2, non-electrical equipment)	EX																																										

Highlights Key (Denotes part number availability)

123	Item is standard
123	Item is standard green option
123	Item is semi standard
123	Item is non standard

Note 1: Part numbers featured with bold highlighted codes will ensure a 'standard' product selection.

Note 2: Alternate displayed part number selection will require you to contact Parker Filtration for availability.

Note 1*: For ATEX classified filters add EX after the code.

ATEX certified filters with electrical indicator are available on request.

Visual indicators are classified as Category 2, non electrical equipment.

Filter assemblies with EX code will be supplied with a dedicated name plate.

Pls consult Parker Filtration for any questions related to the classification of our products.



Ordering Information (cont.)

Degree of filtration						Media code
Average filtration beta ratio β (ISO 16889) / particle size μm [c]						
$\beta(x)=2$	$\beta(x)=10$	$\beta(x)=75$	$\beta(x)=100$	$\beta(x)=200$	$\beta(x)=1000$	
% efficiency, based on the above beta ratio (βx)						
50.0%	90.0%	98.7%	99.0%	99.5%	99.9%	02Q/02QL
N/A	N/A	N/A	N/A	N/A	4.5	05Q/05QL
N/A	N/A	4.5	5	6	7	10Q/10QL
N/A	6	8.5	9	10	12	20Q/20QL
6	11	17	18	20	22	

Supersedes spare element table					
BGT390	TXWL8A-2	TXWL8A-5	TXWL8A-10	TXWL8A-20	
Part number spare element	937832Q	937843Q	937858Q	937869Q	
BGT500	TXWL8C-2	TXWL8C-5	TXWL8C-10	TXWL8C-20	
Part number spare element	937833Q	937842Q	937859Q	937868Q	
BGT600	TXWL10-2	TXWL10-5	TXWL10-10	TXWL10-20	
Part number spare element	937834Q	937841Q	937860Q	937867Q	
BGT800	TXWL11-2	TXWL11-5	TXWL11-10	TXWL11-20	
Part number spare element	937835Q	937840Q	937861Q	937866Q	
BGT1000	TXWL12-2	TXWL12-5	TXWL12-10	TXWL12-20	
Part number spare element	937836Q	937839Q	937862Q	937865Q	
BGT1500	TXWL13-2	TXWL13-5	TXWL13-10	TXWL13-20	
Part number spare element	937837Q	937838Q	937863Q	937864Q	

Supersedes spare element table						
BGT390	TXX8A-10-B	TXW8A-2-B	TXW8A-5-B	TXW8A-10-B	TXW8A-20-B	ST8A-40-B
Part number spare element	937728	937742Q	937763Q	937778Q	937799Q	937813
BGT500	TXX8C-10-B	TXW8C-2-B	TXW8C-5-B	TXW8C-10-B	TXW8C-20-B	ST8C-40-B
Part number spare element	937729	937741Q	937764Q	937777Q	937800Q	937812
BGT600	TXX10-10-B	TXW10-2-B	TXW10-5-B	TXW10-10-B	TXW10-20-B	ST10-40-B
Part number spare element	937730	937740Q	937765Q	937776Q	937801Q	937811
BGT800	TXX11-10-B	TXW11-2-B	TXW11-5-B	TXW11-10-B	TXW11-20-B	ST11-40-B
Part number spare element	937731	937739Q	937766Q	937775Q	937802Q	937810
BGT1000	TXX12-10-B	TXW12-2-B	TXW12-5-B	TXW12-10-B	TXW12-20-B	ST12-40-B
Part number spare element	937732	937738Q	937767Q	937774Q	937803Q	937809
BGT1500	TXX13-R-10-B	TXW13-R-2-B	TXW13-R-5-B	TXW13-R-10-B	TXW13-R-20-B	ST13-40-B
Part number spare element	937733	937737Q	937768Q	937773Q	937804Q	937808
BGT2000	TXX14-10-B	TXW14-2-B	TXW14-5-B	TXW14-10-B	TXW14-20-B	ST14-40-B
Part number spare element	937734	937736Q	937769Q	937772Q	937805Q	937807
BGT2400	-	TXWH14-2-B	TXWH14-5-B	TXWH14-10-B	TXWH14-20-B	-
Part number spare element		937735Q	937770Q	937771Q	937806Q	

BGT Series Seal Kits

BGT Filter connection	Nitrile Seal kit
Port(s) Filter head	Part Number
2" SAE BGT length 11 and 12	2049010017
3" SAE BGT Length 13 and larger	2049010023
1x2" SAE Flanged + 2 x 1 1/4" SAE Flanged for BGT Length 11 and 12	918045048
3x1 1/4" SAE Flanges + 1x 1/2" SAE for BGT Length 13 and larger	2049010020

IN-AGB Series

In-Tank Mounted Return Line Filters

Max. 2400 l/min



Flow from inside to out

Designed for in-built filtration

The IN-AGB Series features a quick response bypass construction with low hysteresis, magnetic pre-filtration and a high dirt-holding capacity. Flow rates from 30 l/min to 2400 l/min. *LEIF*[®] elements available up to 1500 l/min. A low cost, high performance filter.



Contact Information:

Parker Hannifin
Hydraulic Filter Division Europe

European Product
Information Centre
Freephone: 00800 27 27 5374
(from AT, BE, CH, CZ, DE, EE, ES,
FI, FR, IE, IT, PT, SE, SK, UK)
filtrationinfo@parker.com

www.parker.com/hfde

Product Features:

- IN-AGB features a bypass construction with low hysteresis.
- Magnetic pre-filtration and a high dirt-holding capacity.
- Wide range of diffusers including airtight options.
- Flow from inside to out.
- Flow rates from 30 l/min to 2400 l/min.
- Patented *LEIF*[®] elements safeguard filtration quality.

IN-AGB Series

In-Tank Mounted Return Line Filters

Features & Benefits

Features	Advantages	Benefits
Filter integrated in tank	Compact low cost solution Filter protected by reservoir	Suitable for extreme heavy duty applications or hazardous environments No tank top parts contributes to improved esthetical design
LEIF® elements	Element safeguards the use of genuine parts	Guaranteed quality of filtration Contributes to ISO 14001 certification
Magnetic pre-filtration	Removes ferrous particles, even during bypass conditions	Improved fluid cleanliness levels Extended element life time
In-to-Out filtration	All captured contamination retains inside the element	No recontamination of system during change of elements
High level of customisation	Dedicated system-matched solutions can be easily made available	Improved integration of filter in system combined with lower initial system costs
Quick response bypass with low hysteresis	Reduction of bypass period due to low hysteresis Only a small part of the total flow is bypassing the element	Improved protection of system
Standard or customised funnel	Ensures that oil enters the tank under the oil level	Significant reduction of oil foaming

Typical Applications

- Agricultural machines
- Articulated dump trucks
- Forestry equipment
- Wheeled loaders
- Lubrication systems
- Excavators

The Parker Filtration IN-AGB In-Tank Mounted Return Line Filters.

The low-cost, high-performance return line IN-AGB filter features Q3 filter media, a bypass construction with low hysteresis, magnetic pre-filtration and a high dirt-holding capacity. The range is capable of handling flow rates from 30 l/min up to 2400 l/min. LEIF® elements are available for flow rates up to 1500 l/min, meeting the most stringent demands for environmentally-friendly filtration and offering protection against poor quality pirate elements.



Specification

Assembly:

Inside tank.

Seal material:

Nitrile, fluoroelastomer, neoprene.

Operating temperature range:

Seal material Nitrile: -40° to +100°C.
Seal material Fluoroelastomer: -20° to +100°C.

Bypass setting:

0.8/1.5 and 2.0 bar.
Other settings on request.

Degree of filtration:

Determined by multipass test according to ISO 16889.

Flow fatigue characteristics:

Filter media is supported so that the optimal fatigue life is achieved.

Filtration media:

Microglass III, Ecoglass III for *LEIF*[®] elements
Also available 10µm Cellulose and 40µm stainless steel mesh.

Element burst rating:

10 bar (ISO 2941).

Options:

Diffuser type P (straight pipe, no perforated plate area)
Diffuser type T (with closed diffuser end cap and with perforated plate area, recommended when oil entry in reservoir is close to the reservoir bottom or to ensure oil entry under the reservoir oil level)

Magnetic pack:

Standard.

Note: IN-AGB 2-400 and 2-500 are standard supplied without magnets.

Filter element:

LEIF[®] element with reusable metal element sleeve.

Optional conventional style element with steel end caps.

The *LEIF*[®] element is patented and safeguards the use of genuine parts.

Note: *LEIF*[®] element can be used with mineral and HEES type oils.
For other fluids consult Parker Filtration.
LEIF[®] contributes to ISO 14001 quality standards.

Insert-AGB <i>LEIF</i> [®] 1-3 series		
Ref.	No.	Description
1	1	Top-spring
2	1	Insert
3	1	Insert-seal
4	1	<i>LEIF</i> [®] Element
5	1	Sleeve
6	1	Gasket
7	1	O-ring
8	1	Bypass set
9	1	Diffuser

Insert-AGB <i>LEIF</i> [®] 4 series		
Ref.	No.	Description
1	1	Top-spring
2	1	Insert
3	1	Insert-seal
4	1	Inner sleeve
5	1	<i>LEIF</i> [®] -element
6	1	Outer sleeve
7	1	O-ring
8	1	O-ring
9	1	Bypass set
10	1	Diffuser

1-3 Series

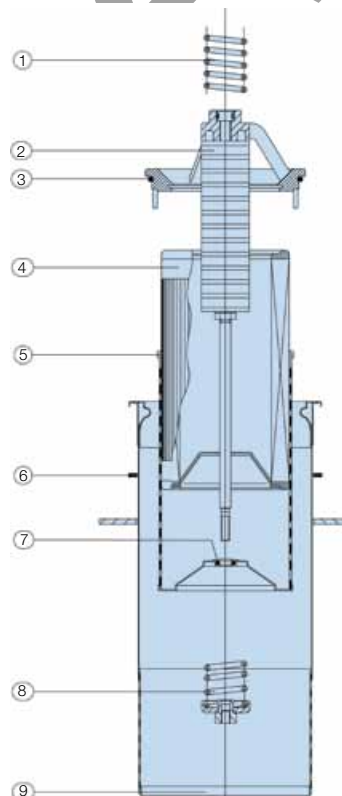

4 Series

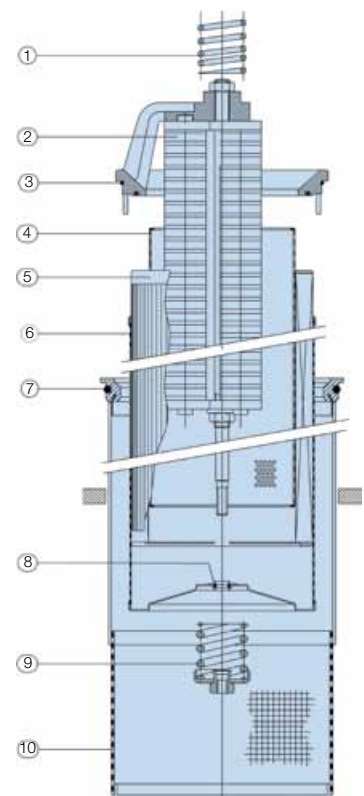

IN-AGB Series

In-Tank Mounted Return Line Filters

Specification (cont.)

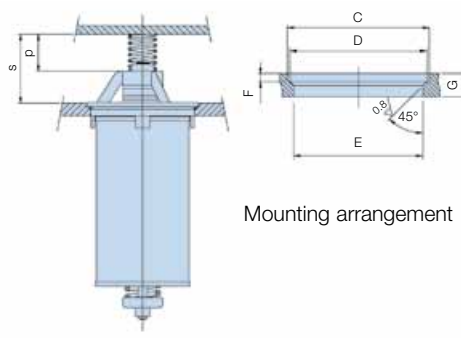
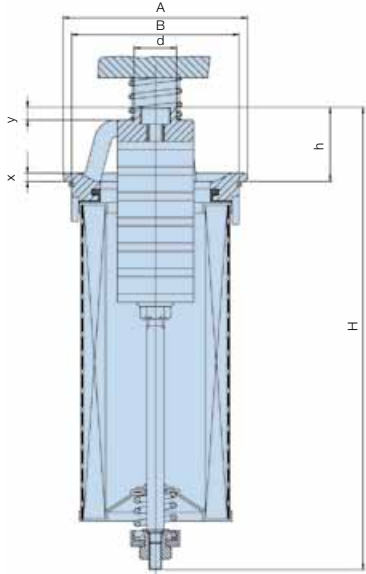

Mounting arrangement

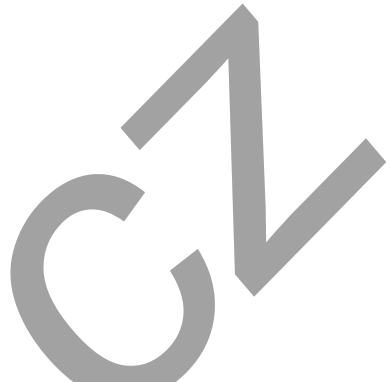

INAGB Length	Type	A	B	H	h	d	x	y	s	p	C	D	E	F	G
1 Series	0 IN30	87	79	122	35	20	4	6	45	20	88	85	80	4	12
	2 IN60	87	79	173	35	20	4	6	45	20	88	85	80	4	12
	3 IN90	87	79	217	35	20	4	6	45	20	88	85	80	4	12
	4 IN120	87	79	267	35	20	4	6	45	20	88	85	80	4	12
2 Series	5 IN125	87	79	381	35	20	4	6	45	20	88	85	80	4	12
	6 IN170	125	116	284	48	25	5	8	77	42	126	122	117	5	15
	7 IN230	125	116	360	48	25	5	8	77	42	126	122	117	5	15
	8 IN300	125	116	559	48	25	5	8	77	42	126	122	117	5	15
3 Series	9 IN400	125	116	579	48	25	5	8	77	42	126	122	117	5	15
	10 IN500	125	116	599	48	25	5	8	77	42	126	122	117	5	15
	11A IN270	150	138	325	62	30	7	12	100	55	151	149	139	5	18
	11 IN390	150	138	407	62	30	7	12	100	55	151	149	139	5	18
3 Series	12 IN500	150	138	599	62	30	7	12	100	55	151	149	139	5	18

Dimensions in mm

without diffuser

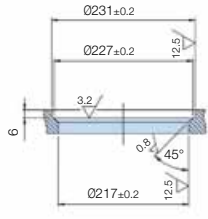
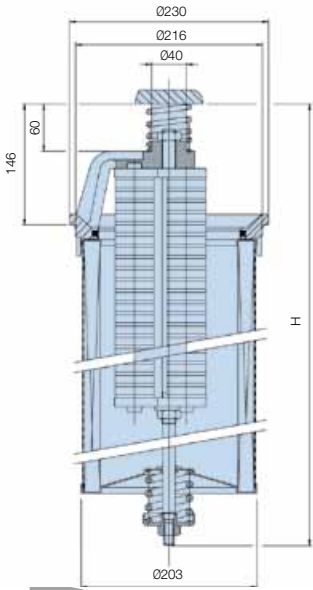

without diffuser

INAGB Length	Type	H
13	IN600	543
14	IN800	653
15	IN1000	758
16	IN1500	1038
17	IN2000	1303
18	IN2400	1303

Dimensions in mm

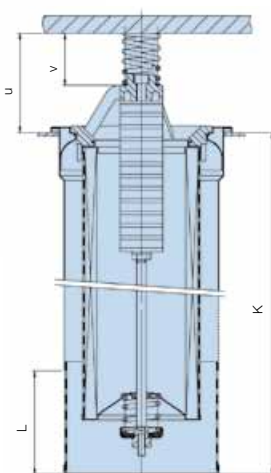

with diffuser

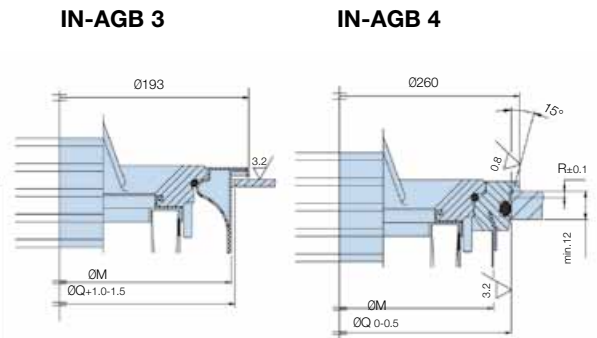

INAGB Length	Type	K	L	M	U	V	Q	R
3 Series	11A IN270	324	110	175	106	55	178	
	11 IN390	364	110	175	106	55	178	
	12 IN500(3)	554	125	175	106	55	178	
4 Series	13 IN600	445	183	239	145	60	250.5	2.5
	14 IN800	555	183	239	145	60	250.5	2.5
	15 IN1000	660	183	239	145	60	250.5	2.5
	16 IN1500	940	183	239	145	60	250.5	2.5
	17 IN2000	1220	183	239	145	60	250.5	2.5
4 Series	18 IN2400	1220	183	239	145	60	250.5	2.5

Dimensions in mm



Pressure Drop Curves

The recommended level of the initial pressure drop for low pressure filters is max 0.5 bar.

If the medium used has a viscosity different from 32cSt, pressure drop over the filter can be estimated as follows:

$$\Delta p = (\Delta p_{32} \times \text{viscosity of medium used}) / 32\text{cSt}$$

Filter housing and element pressure drop based on 32cSt fluid viscosity and 0.87 density.

IN30 (Element length code 0)

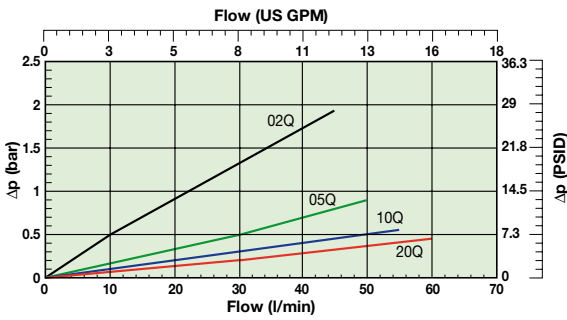

IN60 (Element length code 2)

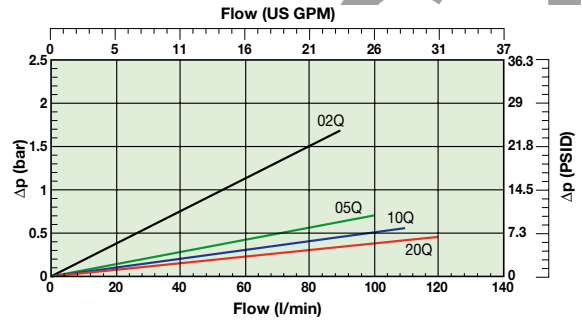

IN90 (Element length code 3)

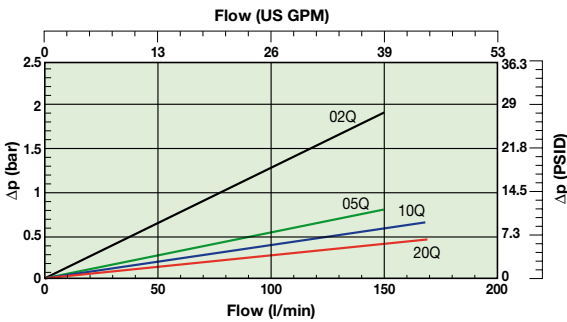

IN120 (Element length code 4)

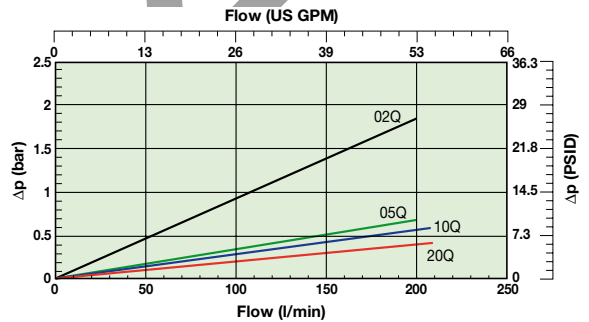

IN150 (Element length code 5)

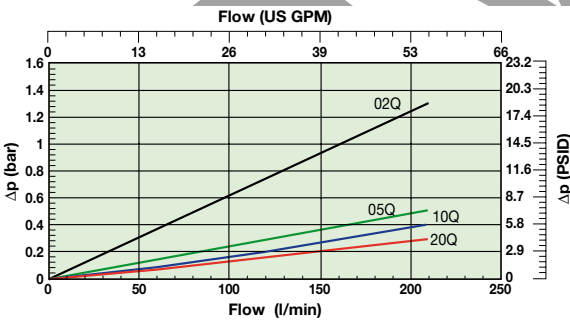

IN170 (Element length code 6)

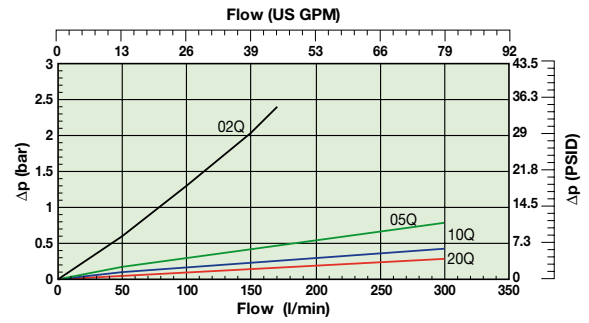

IN230 (Element length code 7)

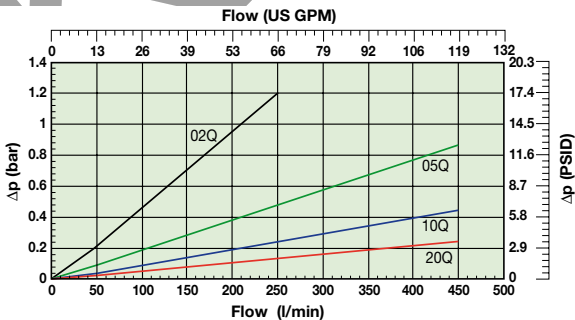

IN300 (Element length code 8)

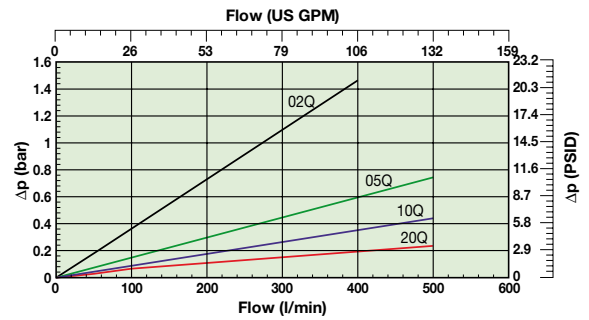

IN-AGB Series

In-Tank Mounted Return Line Filters

Pressure Drop Curves (cont.)

IN400 (Element length code 9)

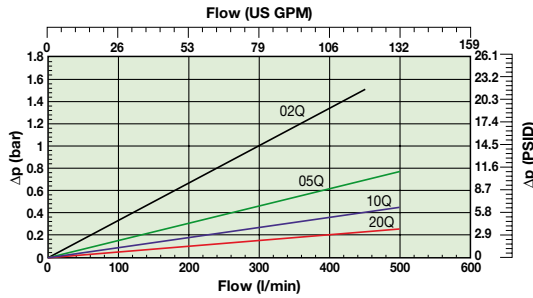

IN500 (Element length code 10)

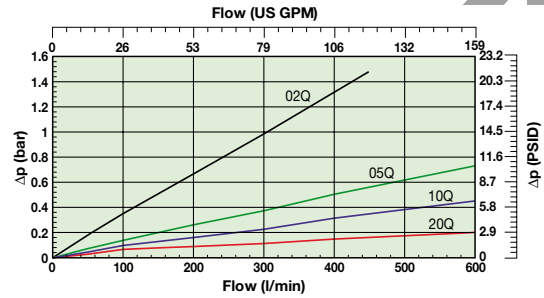

IN390 (3)(Element length code 11)

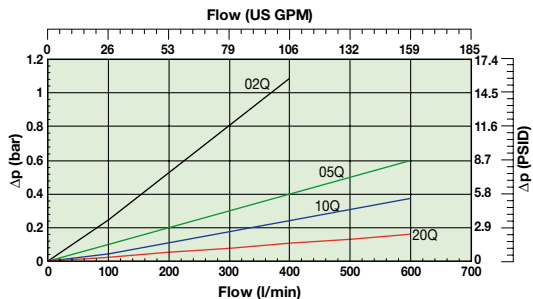

IN500 (3) (Element length code 12)

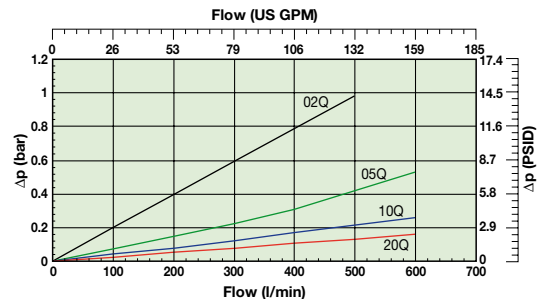

IN600 (Element length code 13)

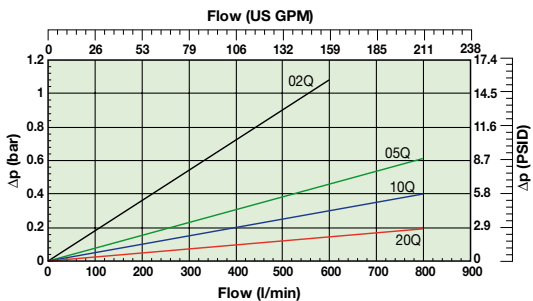

IN800 (Element length code 14)

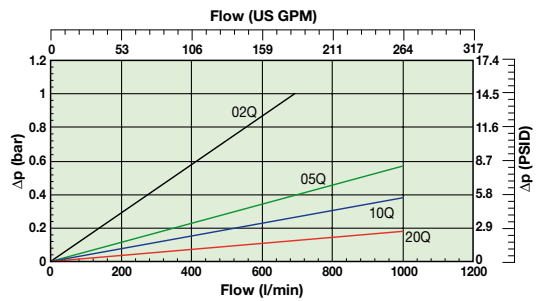

IN1000 (Element length code 15)

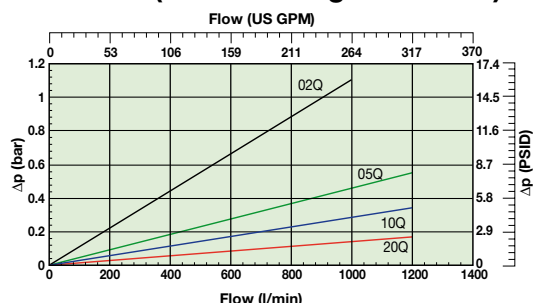

IN1500 (Element length code 16)

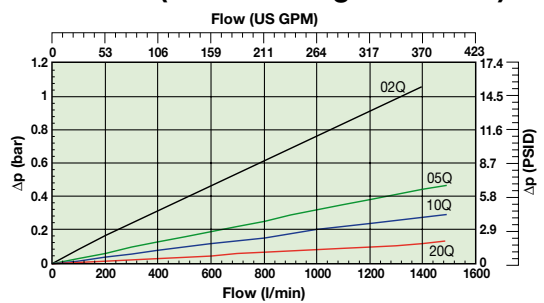

IN2000 (Element length code 17)

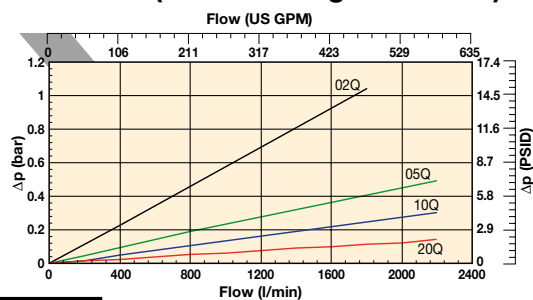

IN2400 (Element length code 18)

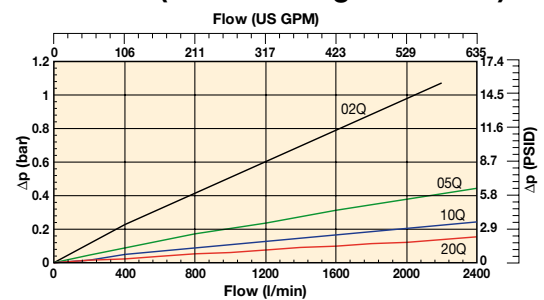

Pressure Drop Curves (cellulose and stainless steel media)

IN30 (Element length code 0)
Cellulose & Stainless steel media

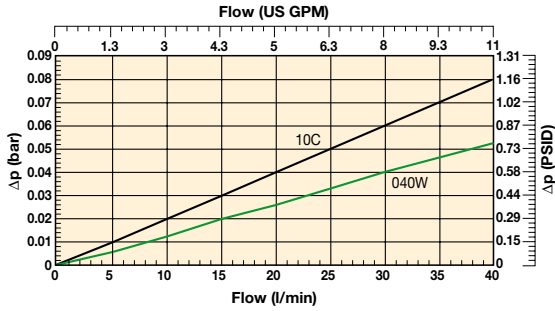

IN60 (Element length code 2)
Cellulose & Stainless steel media

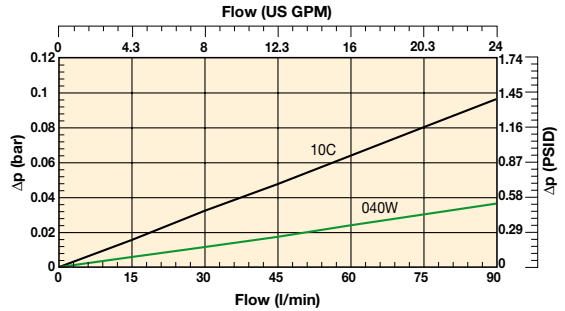

IN90 (Element length code 3)
Cellulose & Stainless steel media

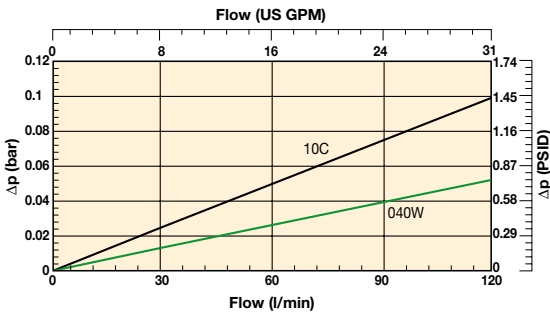

IN120 (Element length code 4)
Cellulose & Stainless steel media

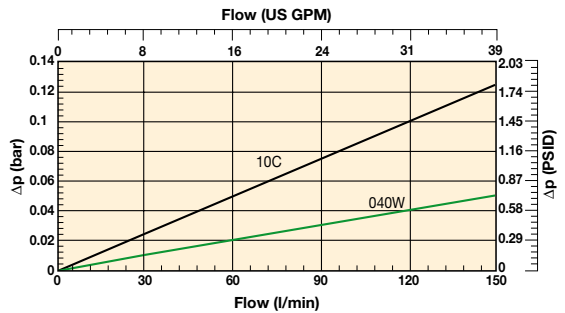

IN150 (Element length code 5)
Cellulose & Stainless steel media

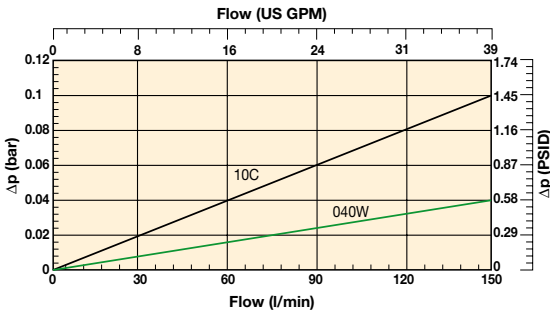

IN170 (Element length code 6)
Cellulose & Stainless steel media

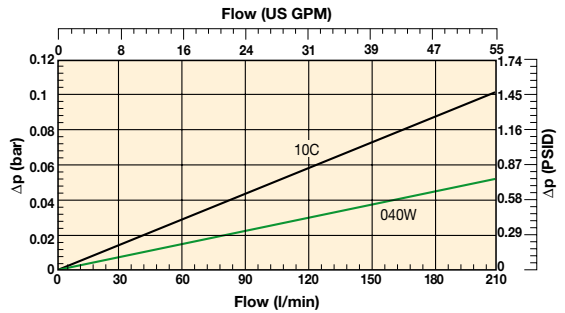

IN230 (Element length code 7)
Cellulose & Stainless steel media

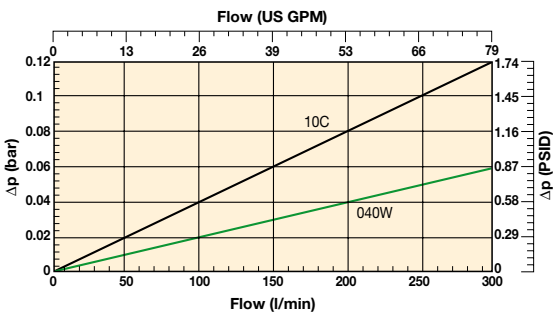

IN300 (Element length code 8)
Cellulose & Stainless steel media

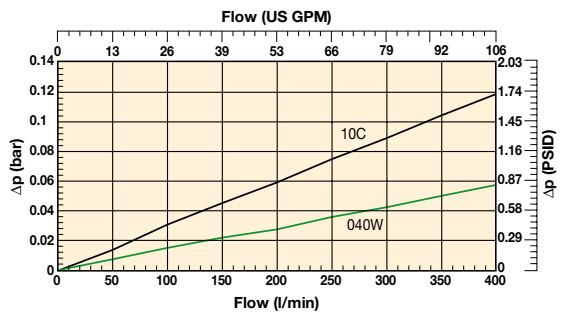

Cellulose and stainless steel media
Example: IN300 Filter Element Length 8 - Cellulose and stainless steel media



IN-AGB Series

In-Tank Mounted Return Line Filters

Pressure Drop Curves (cellulose and stainless steel media)

IN390 (Element length code 11)
Cellulose & Stainless steel media

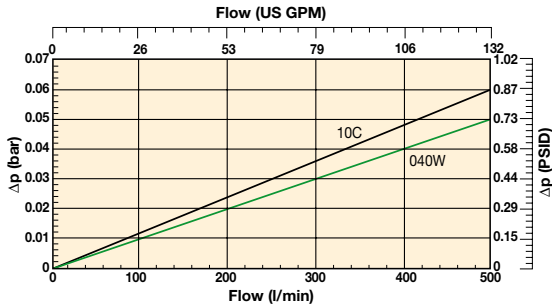

IN500 (Element length code 12)
Cellulose & Stainless steel media

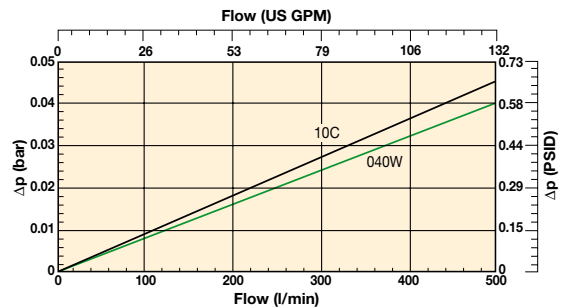

IN600 (Element length code 13)
Cellulose & Stainless steel media

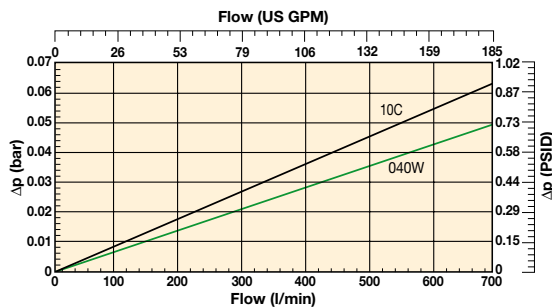

IN800 (Element length code 14)
Cellulose & Stainless steel media

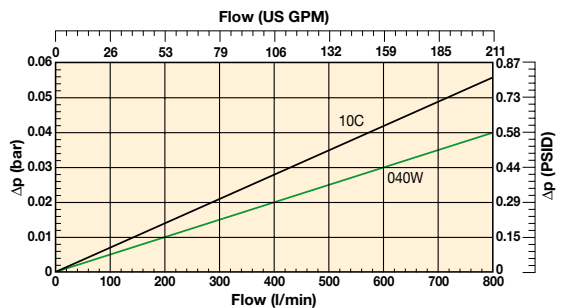

IN1000 (Element length code 15)
Cellulose & Stainless steel media

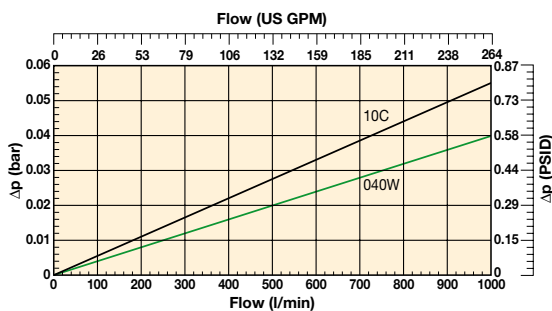

IN1500 (Element length code 16)
Cellulose & Stainless steel media

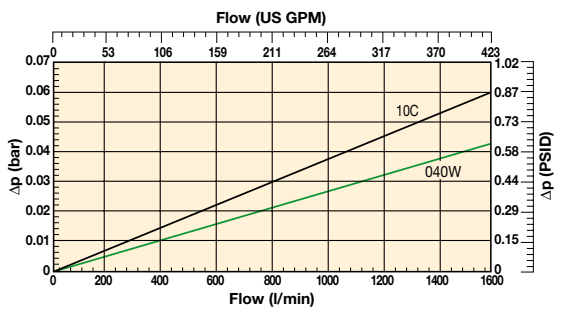

IN2000 (Element length code 17)
Cellulose & Stainless steel media

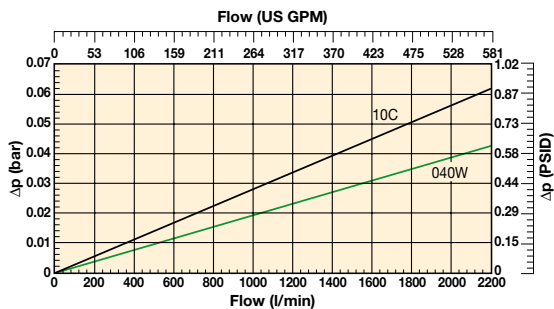

Cellulose and stainless steel media
Example: IN300 Filter Element Length 8 - Cellulose and stainless steel media

Ordering Information

Standard products table

Part number	Supersedes	Flow (l/min)	Model number	Element length	Media rating (µ)	Seals	Indicator	Bypass settings	Ports	Included options	Replacement elements	Supersedes
IN310QLBNEXX1	IN90-TXWL3-10B15	90	IN90	Length 3	10	Nitrile	NA	1.5 Bar (22 Psi)	NA	None	937878Q	TXWL3-10
IN320QLBNEXX1	IN90-TXWL3-20 B15	90	IN90	Length 3	20	Nitrile	NA	1.5 Bar (22 Psi)	NA	None	937877Q	TXWL3-20
IN510QLBNEXX1	IN125-TXWL3E-10 B15	125	IN125	Length 5	10	Nitrile	NA	1.5 Bar (22 Psi)	NA	None	937852Q	TXWL3E-10
IN520QLBNEXX1	IN125-TXWL3E-20 B15	125	IN125	Length 5	20	Nitrile	NA	1.5 Bar (22 Psi)	NA	None	937875Q	TXWL3E-20
IN610QLBNEXX1	IN170-TXWL4-10 B15	170	IN170	Length 6	10	Nitrile	NA	1.5 Bar (22 Psi)	NA	None	937853Q	TXWL4-10
IN620QLBNEXX1	IN170-TXWL4-20 B15	170	IN170	Length 6	20	Nitrile	NA	1.5 Bar (22 Psi)	NA	None	937874Q	TXWL4-20
IN810QLBNEXX1	IN300-TXWL5A-10 B15	300	IN300	Length 8	10	Nitrile	NA	1.5 Bar (22 Psi)	NA	None	937855Q	TXWL5A-10
IN820QLBNEXX1	IN300-TXWL5A-20 B15	300	IN300	Length 8	20	Nitrile	NA	1.5 Bar (22 Psi)	NA	None	937872Q	TXWL5A-20
IN1210QLBNEXX3	IN500-TXWL8C-10 T B15	500	IN500	Length 12	10	Nitrile	NA	1.5 Bar (22 Psi)	NA	Diffuser type T	937859Q	TXWL8C-10
IN1220QLBNEXX3	IN500-TXWL8C-20 T B15	500	IN500	Length 12	20	Nitrile	NA	1.5 Bar (22 Psi)	NA	Diffuser type T	937868Q	TXWL8C-20
IN1510QLBNEXX3	IN1000-TXWL12-10 T B15	1000	IN1000	Length 15	10	Nitrile	NA	1.5 Bar (22 Psi)	NA	Diffuser type T	937862Q	TXWL12-10
IN1520QLBNEXX3	IN1000-TXWL12-20 T B15	1000	IN1000	Length 15	20	Nitrile	NA	1.5 Bar (22 Psi)	NA	Diffuser type T	937865Q	TXWL12-20
IN1710QBNEXX3	IN2000-TXW14-10-B T B15	2000	IN2000	Length 17	10	Nitrile	NA	1.5 Bar (22 Psi)	NA	Diffuser type T	937772Q	TXW14-10B
IN1720QBNEXX3	IN2000-TXW14-20-B T B15	2000	IN2000	Length 17	20	Nitrile	NA	1.5 Bar (22 Psi)	NA	Diffuser type T	937805Q	TXW14-20B

Note: Filter assemblies ordered from the product configurator below are on extended lead times. Where possible, please make your selection from the table above.

Product configurator

Configurator example filter including LEIF® element

Box 1	Box 2	Box 3	Box 4	Box 5	Box 6	Box 7	Box 8
IN	10	05QL	V	N	H	XXX	1

Configurator example filter including conventional element

Box 1	Box 2	Box 3	Box 4	Box 5	Box 6	Box 7	Box 8
IN	18	20Q	B	N	H	XXX	3

Box 1	Box 2	Box 3	Box 4	Box 5	Box 6	Box 7	Box 8																																																																																																																	
Code	Filter Rating	Degree of filtration																																																																																																																						
IN	<table border="1"> <thead> <tr> <th>Insert IN-AGB</th> <th>Code</th> </tr> </thead> <tbody> <tr><td>IN30</td><td>0</td></tr> <tr><td>IN60</td><td>2</td></tr> <tr><td>IN90</td><td>3</td></tr> <tr><td>IN120</td><td>4</td></tr> <tr><td>IN150</td><td>5</td></tr> <tr><td>IN170</td><td>6</td></tr> <tr><td>IN230</td><td>7</td></tr> <tr><td>IN300</td><td>8</td></tr> <tr><td>IN400</td><td>9</td></tr> <tr><td>IN500</td><td>10</td></tr> <tr><td>IN390(3)</td><td>11</td></tr> <tr><td>IN270(3)</td><td>11A</td></tr> <tr><td>IN500(3)</td><td>12</td></tr> <tr><td>IN600</td><td>13</td></tr> <tr><td>IN800</td><td>14</td></tr> <tr><td>IN1000</td><td>15</td></tr> <tr><td>IN1500</td><td>16</td></tr> <tr><td>IN2000</td><td>17</td></tr> <tr><td>IN2400</td><td>18</td></tr> </tbody> </table>	Insert IN-AGB	Code	IN30	0	IN60	2	IN90	3	IN120	4	IN150	5	IN170	6	IN230	7	IN300	8	IN400	9	IN500	10	IN390(3)	11	IN270(3)	11A	IN500(3)	12	IN600	13	IN800	14	IN1000	15	IN1500	16	IN2000	17	IN2400	18	<table border="1"> <thead> <tr> <th>Element media</th> <th colspan="4">Glass fibre</th> <th>Wire mesh</th> </tr> <tr> <td rowspan="2">Disposable element</td> <td colspan="4">Microglass III (for disposable elements)</td> <td rowspan="2">Abs. rating</td> </tr> <tr> <td>Cellulose</td> <td colspan="3">Ecoglass III (for LEIF® elements)</td> </tr> <tr> <td>LEIF® element</td> <td>Nom. rating</td> <td></td> <td></td> <td></td> <td>040W</td> </tr> </thead> <tbody> <tr> <td></td> <td>10C</td> <td>02Q</td> <td>05Q</td> <td>10Q</td> <td>20Q</td> </tr> <tr> <td></td> <td></td> <td>02QL</td> <td>05QL</td> <td>10QL</td> <td>20QL</td> </tr> </tbody> </table>	Element media	Glass fibre				Wire mesh	Disposable element	Microglass III (for disposable elements)				Abs. rating	Cellulose	Ecoglass III (for LEIF® elements)			LEIF® element	Nom. rating				040W		10C	02Q	05Q	10Q	20Q			02QL	05QL	10QL	20QL	<table border="1"> <thead> <tr> <th>Seal type</th> <th>Code</th> </tr> </thead> <tbody> <tr> <td>Seal material</td> <td></td> </tr> <tr> <td>Nitrile</td> <td>B</td> </tr> <tr> <td>Fluoroelastomer</td> <td>V</td> </tr> <tr> <td>Neoprene</td> <td>On request</td> </tr> </tbody> </table>	Seal type	Code	Seal material		Nitrile	B	Fluoroelastomer	V	Neoprene	On request	<table border="1"> <thead> <tr> <th>Indicator</th> <th>Code</th> </tr> </thead> <tbody> <tr> <td>No indicator</td> <td>N</td> </tr> </tbody> </table>	Indicator	Code	No indicator	N	<table border="1"> <thead> <tr> <th>Filter connection</th> <th>Code</th> </tr> </thead> <tbody> <tr> <td>Ports</td> <td></td> </tr> <tr> <td>No ports applicable</td> <td>XXX</td> </tr> </tbody> </table>	Filter connection	Code	Ports		No ports applicable	XXX	<table border="1"> <thead> <tr> <th>Options</th> <th>Code</th> </tr> </thead> <tbody> <tr> <td>Options</td> <td></td> </tr> <tr> <td>No diffuser required</td> <td>1</td> </tr> <tr> <td>Diffuser type T with perforated plate area</td> <td>3</td> </tr> <tr> <td>Diffuser type P without perforated plate area</td> <td>4</td> </tr> <tr> <td>No magnets</td> <td>5</td> </tr> <tr> <td>Diffuser type T and no magnets</td> <td>A</td> </tr> <tr> <td>Diffuser type P and no magnets</td> <td>B</td> </tr> <tr> <td>Air tight diffuser type T and no magnets</td> <td>G</td> </tr> <tr> <td>Air tight diffuser type P and no magnets</td> <td>H</td> </tr> </tbody> </table>	Options	Code	Options		No diffuser required	1	Diffuser type T with perforated plate area	3	Diffuser type P without perforated plate area	4	No magnets	5	Diffuser type T and no magnets	A	Diffuser type P and no magnets	B	Air tight diffuser type T and no magnets	G	Air tight diffuser type P and no magnets	H
Insert IN-AGB	Code																																																																																																																							
IN30	0																																																																																																																							
IN60	2																																																																																																																							
IN90	3																																																																																																																							
IN120	4																																																																																																																							
IN150	5																																																																																																																							
IN170	6																																																																																																																							
IN230	7																																																																																																																							
IN300	8																																																																																																																							
IN400	9																																																																																																																							
IN500	10																																																																																																																							
IN390(3)	11																																																																																																																							
IN270(3)	11A																																																																																																																							
IN500(3)	12																																																																																																																							
IN600	13																																																																																																																							
IN800	14																																																																																																																							
IN1000	15																																																																																																																							
IN1500	16																																																																																																																							
IN2000	17																																																																																																																							
IN2400	18																																																																																																																							
Element media	Glass fibre				Wire mesh																																																																																																																			
Disposable element	Microglass III (for disposable elements)				Abs. rating																																																																																																																			
	Cellulose	Ecoglass III (for LEIF® elements)																																																																																																																						
LEIF® element	Nom. rating				040W																																																																																																																			
	10C	02Q	05Q	10Q	20Q																																																																																																																			
		02QL	05QL	10QL	20QL																																																																																																																			
Seal type	Code																																																																																																																							
Seal material																																																																																																																								
Nitrile	B																																																																																																																							
Fluoroelastomer	V																																																																																																																							
Neoprene	On request																																																																																																																							
Indicator	Code																																																																																																																							
No indicator	N																																																																																																																							
Filter connection	Code																																																																																																																							
Ports																																																																																																																								
No ports applicable	XXX																																																																																																																							
Options	Code																																																																																																																							
Options																																																																																																																								
No diffuser required	1																																																																																																																							
Diffuser type T with perforated plate area	3																																																																																																																							
Diffuser type P without perforated plate area	4																																																																																																																							
No magnets	5																																																																																																																							
Diffuser type T and no magnets	A																																																																																																																							
Diffuser type P and no magnets	B																																																																																																																							
Air tight diffuser type T and no magnets	G																																																																																																																							
Air tight diffuser type P and no magnets	H																																																																																																																							
Box 6																																																																																																																								
Bypass valve																																																																																																																								
<table border="1"> <thead> <tr> <th>Bypass valve</th> <th>Code</th> </tr> </thead> <tbody> <tr> <td>0.8 bar</td> <td>B</td> </tr> <tr> <td>1.5 bar</td> <td>E</td> </tr> <tr> <td>2.0 bar for IN-AGB (up to length 12)</td> <td>H</td> </tr> <tr> <td>Blocked bypass</td> <td>X</td> </tr> <tr> <td>Other bypass settings</td> <td>on request</td> </tr> </tbody> </table>	Bypass valve	Code	0.8 bar	B	1.5 bar	E	2.0 bar for IN-AGB (up to length 12)	H	Blocked bypass	X	Other bypass settings	on request																																																																																																												
Bypass valve	Code																																																																																																																							
0.8 bar	B																																																																																																																							
1.5 bar	E																																																																																																																							
2.0 bar for IN-AGB (up to length 12)	H																																																																																																																							
Blocked bypass	X																																																																																																																							
Other bypass settings	on request																																																																																																																							

Note: IN-AGB size 2-400 and 2-500 are standard supplied without magnets
 Note: Diffusers are only available for series 3 and 4 (Length 11 to 18)

Degree of filtration						Media code
Average filtration beta ratio β (ISO 16889) / particle size µm [c]						
βx(c)=2	βx(c)=10	βx(c)=75	βx(c)=100	βx(c)=200	βx(c)=1000	
% efficiency, based on the above beta ratio (βx)						
50.0%	90.0%	98.7%	99.0%	99.5%	99.9%	
N/A	N/A	N/A	N/A	N/A	4.5	02Q/02QL
N/A	N/A	4.5	5	6	7	05Q/05QL
N/A	6	8.5	9	10	12	10Q/10QL
6	11	17	18	20	22	20Q/20QL



IN-AGB Series

In-Tank Mounted Return Line Filters

Ordering Information (cont.)

Supersedes spare element table				
IN30	TXWL-2	TXWL-5	TXWL-10	TXWL-20
Part number spare element	937822Q	937885Q	937884Q	937883Q
IN60	TXWL2-2	TXWL2-5	TXWL2-10	TXWL2-20
Part number spare element	937823Q	937880Q	937881Q	937882Q
IN90	TXWL3-2	TXWL3-5	TXWL3-10	TXWL3-20
Part number spare element	937824Q	937879Q	937878Q	937877Q
IN120	TXWL3D-2	TXWL3D-5	TXWL3D-10	TXWL3D-20
Part number spare element	937825Q	937850Q	937851Q	937876Q
IN125	TXWL3E-2	TXWL3E-5	TXWL3E-10	TXWL3E-20
Part number spare element	937826Q	937849Q	937852Q	937875Q
IN170	TXWL4-2	TXWL4-5	TXWL4-10	TXWL4-20
Part number spare element	937827Q	937848Q	937853Q	937874Q
IN230	TXWL5-2	TXWL5-5	TXWL5-10	TXWL5-20
Part number spare element	937828Q	937847Q	937854Q	937873Q
IN300	TXWL5A-2	TXWL5A-5	TXWL5A-10	TXWL5A-20
Part number spare element	937829Q	937846Q	937855Q	937872Q
IN400	TXWL5B-2	TXWL5B-5	TXWL5B-10	TXWL5B-20
Part number spare element	937830Q	937845Q	937856Q	937871Q
IN500	TXWL5C-2	TXWL5C-5	TXWL5C-10	TXWL5C-20
Part number spare element	937831Q	937844Q	937857Q	937870Q
IN390	TXWL8A-2	TXWL8A-5	TXWL8A-10	TXWL8A-20
Part number spare element	937832Q	937843Q	937858Q	937869Q
IN500	TXWL8C-2	TXWL8C-5	TXWL8C-10	TXWL8C-20
Part number spare element	937833Q	937842Q	937859Q	937868Q
IN600	TXWL10-2	TXWL10-5	TXWL10-10	TXWL10-20
Part number spare element	937834Q	937841Q	937860Q	937867Q
IN800	TXWL11-2	TXWL11-5	TXWL11-10	TXWL11-20
Part number spare element	937835Q	937840Q	937861Q	937866Q
IN1000	TXWL12-2	TXWL12-5	TXWL12-10	TXWL12-20
Part number spare element	937836Q	937839Q	937862Q	937865Q
IN1500	TXWL13-2	TXWL13-5	TXWL13-10	TXWL13-20
Part number spare element	937837Q	937838Q	937863Q	937864Q

IN-AGB Series Seal Kits	
Part Number	Description
2049010003	NITRILE SEAL KIT IN 0 - 5
2049010045	FLUOROELASTOMER SEAL KIT IN 0 - 5
2049010004	NITRILE SEAL KIT IN 6 - 10
2049010028	FLUOROELASTOMER SEAL KIT IN 6 - 10
2049010005	NITRILE SEAL KIT IN 11 and 12
2049010021	NITRILE SEAL KIT (FUNNEL) IN 11 and 12
2049010029	FLUOROELASTOMER SEAL KIT IN 11 and 12
2049010059	FLUOROELASTOMER SEAL (FUNNEL) KIT IN 11 and 12
2049010006	NITRILE SEAL KIT IN 13 - 18
2049010022	NITRILE SEAL KIT (FUNNEL) IN 13 - 18
2049010030	FLUOROELASTOMER SEAL KIT IN 13 - 18

Supersedes spare element table						
IN30	TXX-10-B	TXW-2-B	TXW-5-B	TXW-10-B	TXW-20-B	ST-40-B
Part number spare element	937720	937752Q	937753Q	937788Q	937789Q	937821
IN60	TXX2-10-B	TXW2-2-B	TXW2-5-B	TXW2-10-B	TXW2-20-B	ST2-40-B
Part number spare element	937721	937751Q	937754Q	937787Q	937790Q	937820
IN90	TXX3-10-B	TXW3-2-B	TXW3-5-B	TXW3-10-B	TXW3-20-B	ST3-40-B
Part number spare element	937722	937750Q	937755Q	937786Q	937791Q	937819
IN120	TXX3D-10-B	TXW3D-2-B	TXW3D-5-B	TXW3D-10-B	TXW3D-20-B	ST3D-40-B
Part number spare element	937723	937749Q	937756Q	937785Q	937792Q	937818
IN125	TXX3E-10-B	TXW3E-2-B	TXW3E-5-B	TXW3E-10-B	TXW3E-20-B	ST3E-40-B
Part number spare element	937724	937748Q	937757Q	937784Q	937793Q	937817
IN170	TXX4-10-B	TXW4-2-B	TXW4-5-B	TXW4-10-B	TXW4-20-B	ST4-40-B
Part number spare element	937725	937747Q	937758Q	937783Q	937794Q	937816
IN230	TXX5-10-B	TXW5-2-B	TXW5-5-B	TXW5-10-B	TXW5-20-B	ST5-40-B
Part number spare element	937726	937746Q	937759Q	937782Q	937795Q	937815
IN300	TXX5A-10-B	TXW5A-2-B	TXW5A-5-B	TXW5A-10-B	TXW5A-20-B	ST5A-40-B
Part number spare element	937727	937745Q	937760Q	937781Q	937796Q	937814
IN390	TXX8A-10-B	TXW8A-2-B	TXW8A-5-B	TXW8A-10-B	TXW8A-20-B	ST8A-40-B
Part number spare element	937728	937742Q	937763Q	937778Q	937799Q	937813
IN500 (3 series)	TXX8C-10-B	TXW8C-2-B	TXW8C-5-B	TXW8C-10-B	TXW8C-20-B	ST8C-40-B
Part number spare element	937729	937741Q	937764Q	937777Q	937800Q	937812
IN600	TXX10-10-B	TXW10-2-B	TXW10-5-B	TXW10-10-B	TXW10-20-B	ST10-40-B
Part number spare element	937730	937740Q	937765Q	937776Q	937801Q	937811
IN800	TXX11-10-B	TXW11-2-B	TXW11-5-B	TXW11-10-B	TXW11-20-B	ST11-40-B
Part number spare element	937731	937739Q	937766Q	937775Q	937802Q	937810
IN1000	TXX12-10-B	TXW12-2-B	TXW12-5-B	TXW12-10-B	TXW12-20-B	ST12-40-B
Part number spare element	937732	937738Q	937767Q	937774Q	937803Q	937809
IN1500	TXX13-R-10-B	TXW13-R-2-B	TXW13-R-5-B	TXW13-R-10-B	TXW13-R-20-B	ST13-40-B
Part number spare element	937733	937737Q	937768Q	937773Q	937804Q	937808
IN2000	TXX14-10-B	TXW14-2-B	TXW14-5-B	TXW14-10-B	TXW14-20-B	ST14-20
Part number spare element	937734	937736Q	937769Q	937772Q	937805Q	937807
IN2400	-	TXWH14-2-B	TXWH14-5-B	TXWH14-10-B	TXWH14-20-B	-
Part number spare element	-	937735Q	937770Q	937771Q	937806Q	-

Tanktopper Series I, II & III

Tanktop Mounted Return Line Filters
with Integrated Air Breather

Max. 650 l/min - 10 bar



When an all-in-one solution matters

Reduction of reservoir accessories

The Tanktopper Series features an integrated, 10 micron Abs. air breather. Maximum pressure 10 bar. Maximum flow 650 l/min. *LEIF*[®] elements available. An all-in-one, easy-to-mount filter range for more compact tank design.



Contact Information:

Parker Hannifin
Hydraulic Filter Division Europe

European Product
Information Centre

Freephone: 00800 27 27 5374
(from AT, BE, CH, CZ, DE, EE, ES,
FI, FR, IE, IT, PT, SE, SK, UK)
filtrationinfo@parker.com

www.parker.com/hfde

Product Features:

- Tanktopper offers a total filtration solution with integrated air breather.
- In-to-Out filtration plus gauge and switch options.
- Maximum pressure 10 bar. Maximum flow 650 l/min.
- Patented *LEIF*[®] elements safeguard filtration quality.

Tanktopper Series I, II & III

Tanktop Mounted Return Line Filters with Integrated Air Breather

Features & Benefits

Features	Advantages	Benefits
Return line filter with integrated airbreather	All in one filter	More compact design, cost reduction due to elimination of loose airbreather
Airbreather equipped with high quality labyrinth	No oil leakage through the airbreather	Improved efficiency of airbreather No oil leakage on the tank / in the environment
Second port and dipstick available	Filler port and level indicator function can be integrated in filter	Significant reduction of reservoir accessories
Airbreather element always supplied with spare return line filter elements	Both filter elements can be replaced during the service event	Improved protection of system due to change of airbreather element
LEIF® elements	Element safeguards the use of genuine parts	Guaranteed quality of filtration Contributes to ISO 14001 certification
Magnetic pre-filtration	Removes ferrous particles, even during bypass conditions	Improved fluid cleanliness levels Extended element life time
In-to-Out filtration	All captured contamination retains inside the element	No recontamination of system during change of elements
Full flow bypass with low hysteresis	Reduction of bypass period due to low hysteresis	Improved protection of system
	Only a small part of the total flow is bypassing the element	
Standard or customised funnel	Ensures that oil enters the tank under the oil level	Significant reduction of oil foaming

Typical Applications

TPR I

- Fork lift trucks
- Power packs
- Mini excavator

TPR II

- Gully-sucker
- Power packs
- Dredging ships

TPR III

- Mobile cranes
- Refuse vehicles

The Parker Filtration Tanktopper Series I, II & III Tanktop Mounted Return Line Filters.

The TPR Series I, II & III offer a total filtration solution. A 10-micron Abs. air breather that is integrated into the filter housing, a magnet column for pre-filtration, 'In-to-Out' filtration, a full-flow bypass with low hysteresis, and the high performance Q3 filter element materials are all proven success factors in efficient return-line filtration for flow rates up to 650 l/min. Several pressure gauges and switches can be applied, combined or not with a dipstick. The all-in-one, easy-to-mount cost-saving TPR solution allows for a more compact tank design.



Specification

Operation pressure:

Max. 10 bar.

Assembly:

Tank top mounted.

Connections:

Threaded BSP or SAE ports.
Second return port available for Tanktopper II and Tanktopper III.

Filter housing:

Aluminium head and co-polymer cover.

Seal material:

Nitrile, Fluoroelastomer.

Operation temperature range:

-40 to +80°C.

Bypass setting:

Opening pressure 0.8, 1.5 or 2.5 bar for Tanktopper I.
Opening pressure 1.5 bar for Tanktopper II and III.

Degree of filtration:

Determined by multipass test according to ISO 16889.

Flow fatigue characteristics:

Filter media is supported so that the optimum fatigue life is achieved.

Filtration media:

Microglass III, Ecoglass III for *LEIF*® element. Air breather 10 micron Abs. Also available 10µm Cellulose and 40µm stainless steel mesh. (TPR1)

Element burst rating:

10 bar (ISO 2941).

Pressure indicator options:

Setting 0.7 or 1.2 bar.
Other settings on request.
Visual pressure gauge.
Electrical pressure switch.

Options:

Dipstick
Second port (only for TPR II and III)

Magnetic pack:

Optional for Tanktopper I.
Standard for Tanktopper II and III.

Filter element:

LEIF® element with reusable metal element sleeve.
Conventional style element with steel end caps only optional for Tanktopper I. The *LEIF*® element is patented and safeguards the use of genuine parts.

Note: *LEIF*® element can be used with mineral and HEES type oils. For other fluids consult Parker Filtration.
LEIF® contributes to ISO 14001 quality standards

Tanktopper I (length 1 and 2)

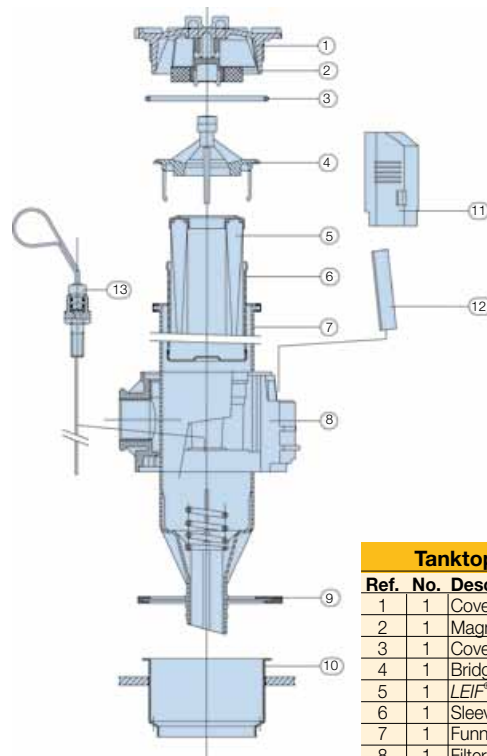
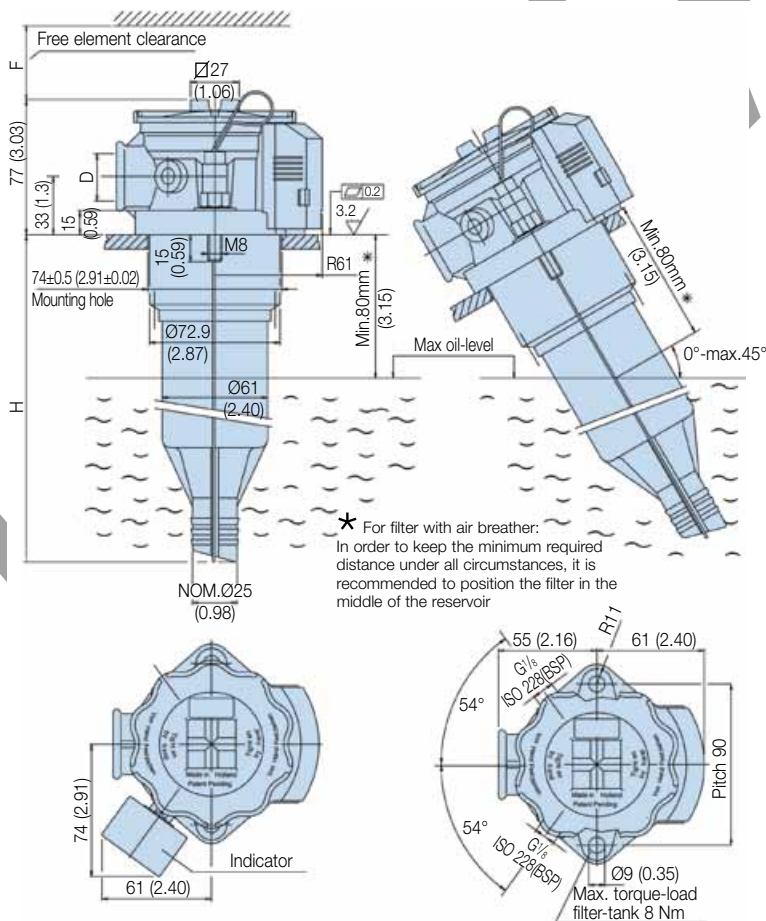

Tanktopper I		
Ref. No.	Description	
1	1	Cover
2	1	Magnet-set
3	1	Cover-seal
4	1	Bridge (blue)
5	1	<i>LEIF</i> ® Element
6	1	Sleeve
7	1	Funnel-assembly
8	1	Filter-housing
9	1	Housing-seal
10	1	Airguide
11	1	Cover airbreather
12	1	Breather-element
13	1	Dipstick assembly

Length		H	F	D
1	TPR1-40	169 (6.65)	160 (6.30)	G _{1/4} (BSP)
2	TPR1-80	269 (10.60)	260 (10.23)	SAE 12

Dimensions in mm



Tanktopper Series I, II & III

Tanktop Mounted Return Line Filters with Integrated Air Breather

Specification (cont.)

Tanktopper II (length 5, 6 and 7)

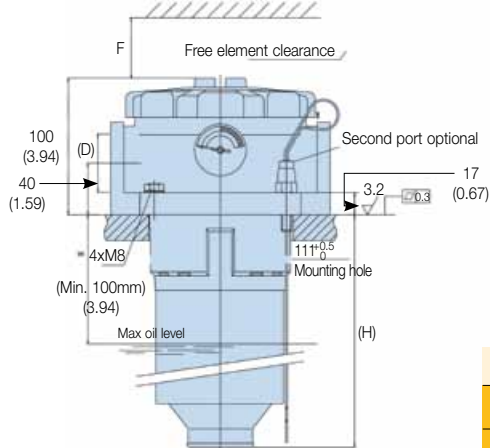

(Port)	D
G1 1/4	(BSP)
G1 1/2	(BSP)
SAE 20	
SAE 24	

Length		H	F
5	TPR2-120	181 (7.12)	170 (6.70)
6	TPR2-200	267 (10.51)	255 (10.03)
7	TPR 2-250	400 (15.75)	380 (14.96)

Dimensions in mm

4x9 on pitch circle Ø145
Torque-load max. 8 Nm (5.70)

ISO 228 G1/8 (BSP)

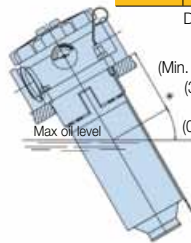
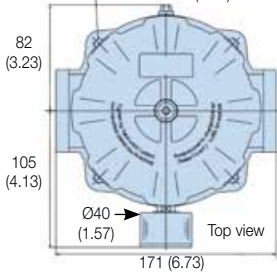

★ For filter with air breather: In order to keep the minimum required distance under all circumstances, it is recommended to position the filter in the middle of the reservoir

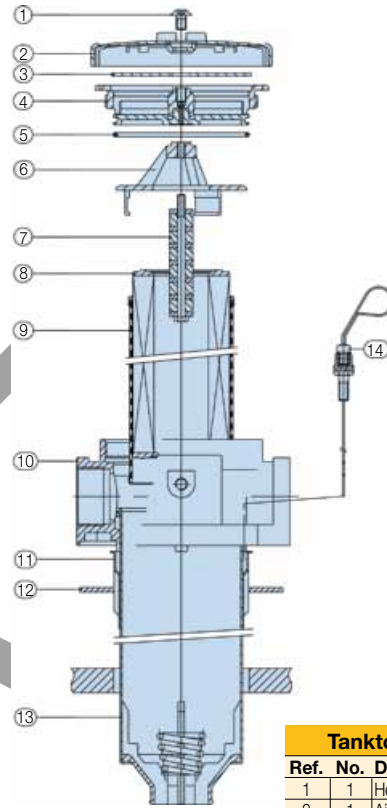

Tanktopper II & III	
Ref. No.	Description
1	1 Hexagon socket bolt M8
2	1 Air breather cap
3	1 Air breather filter medium
4	1 Cover (assembly)
5	1 Cover seal
6	1 Bridge
7	1 Magnet set
8	1 Element
9	1 Sleeve
10	1 Filter house
11	1 Airguide
12	1 Tank gasket
13	1 Funnel
14	1 Dipstick assembly

Tanktopper III (length 10 and 11)

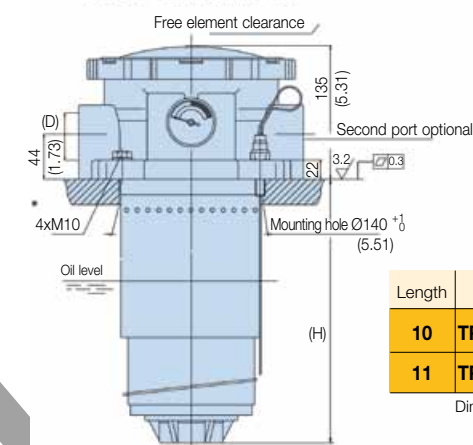

★ For filter with air breather: In order to keep the minimum required distance under all circumstances, it is recommended to position the filter in the middle of the reservoir

Length		D	H	F
10	TPR3-450	-G1 1/2 (BSP)	415 (16.34)	345 (13.58)
11	TPR3-650	-G1 1/2 (BSP)	600 (23.62)	530 (20.87)

Dimensions in mm

4x11 on pitch circle 185
Torque-load max. 15 Nm

ISO 228-G1/8 (BSP)

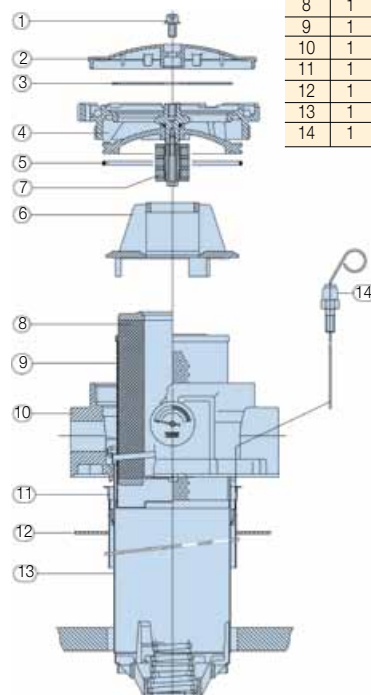
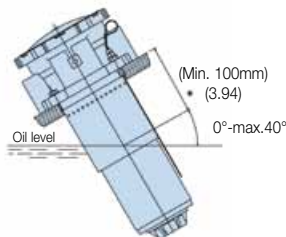
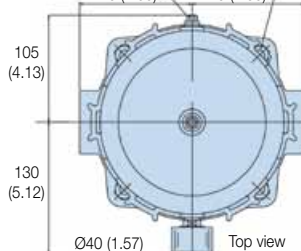

Tanktopper Series I & II

Tanktop Mounted Return Line Filters with Integrated Air Breather

Pressure Drop Curves - Tanktopper I

Filter housing and element pressure drop based on 32cSt fluid viscosity and 0.87 density.

TPR40 Empty Housing (Length code 1)

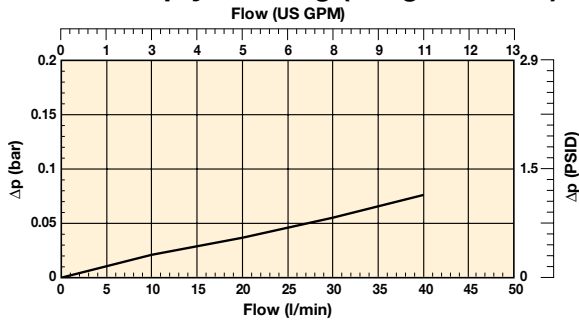

TPR80 Empty Housing (Length code 2)

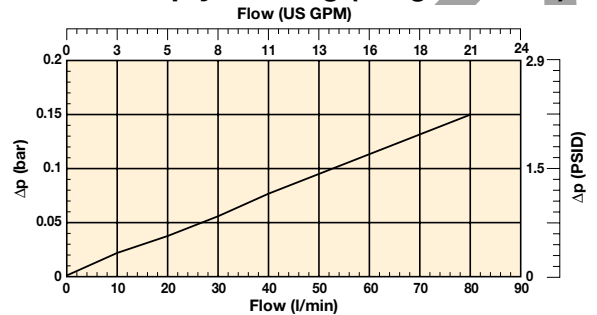

TPR40 (Element length code 1)

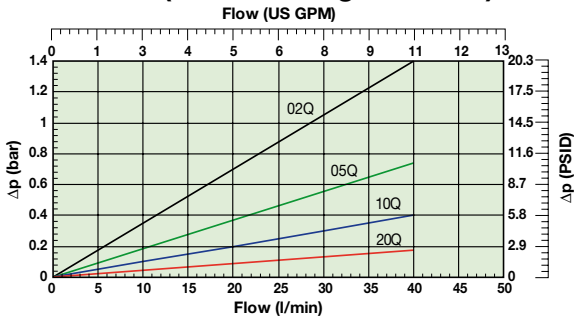

TPR80 (Element length code 2)

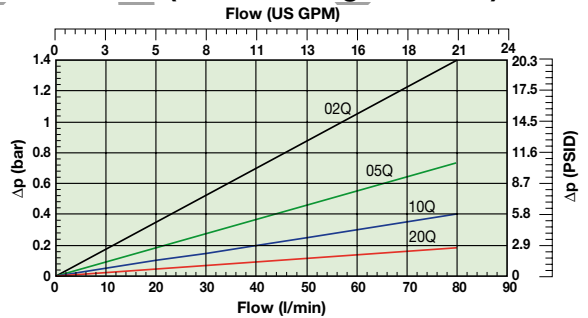

**TPR40 (Element length code 1)
(cellulose and stainless steel)**

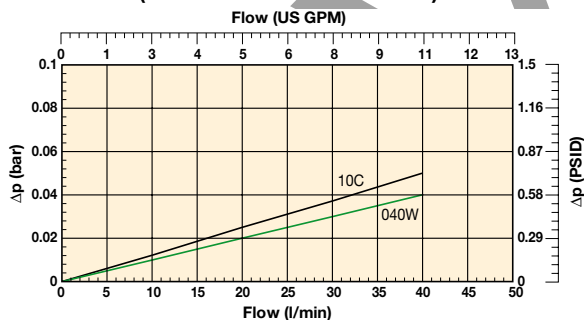

**TPR80 (Element length code 2)
(cellulose and stainless steel)**

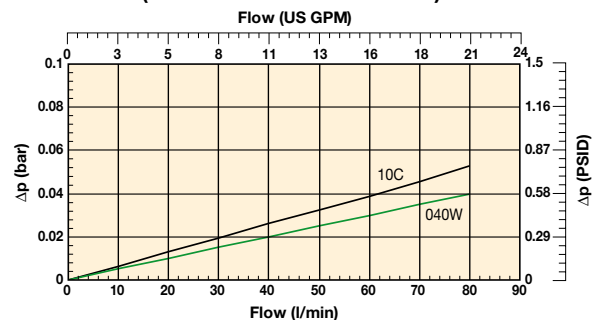

Pressure Drop Curves - Tanktopper II

Filter housing and element pressure drop based on 32cSt fluid viscosity and 0.87 density.

**TPR II Empty Housing with G1¹/₄" ports
(Length code 5, 6 and 7)**

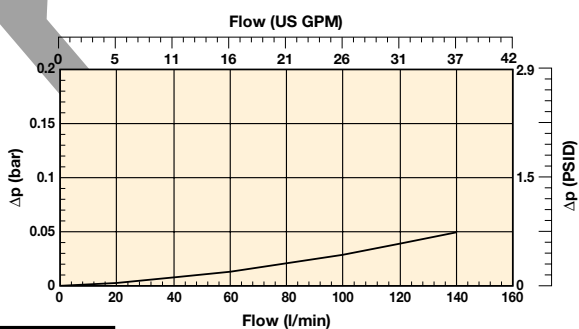

**TPR II Empty Housing with G1¹/₂" ports
(Length code 5, 6 and 7)**

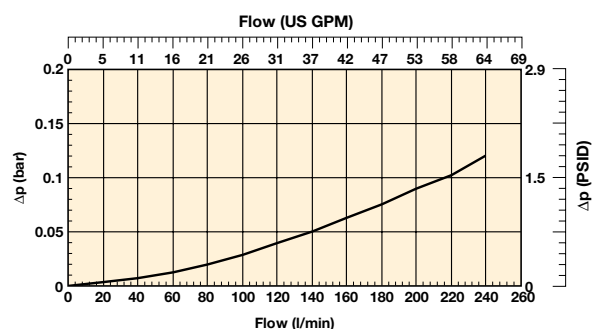

Tanktopper Series II & III

Tanktop Mounted Return Line Filters with Integrated Air Breather

Pressure Drop Curves - Tanktopper II (cont.)

Filter housing and element pressure drop based on 32cSt fluid viscosity and 0.87 density.

TPR120 (Element length code 5)

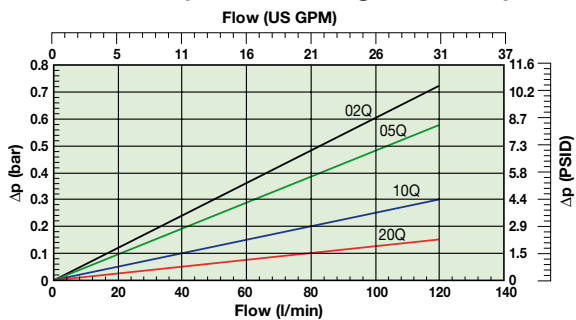

TPR200 (Element length code 6)

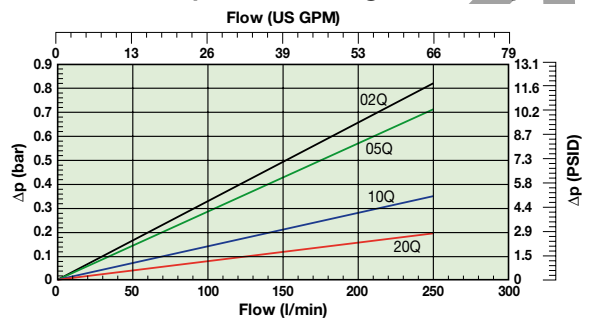

TPR250 (Element length code 7)

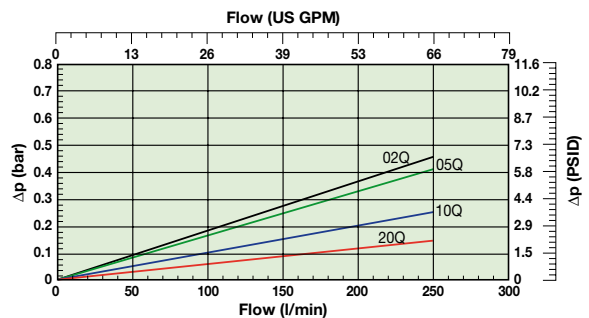

Pressure Drop Curves - Tanktopper III

Filter housing and element pressure drop based on 32cSt fluid viscosity and 0.87 density.

TPR III Empty Housing with G1 1/2" ports (Length code 10 and 11)

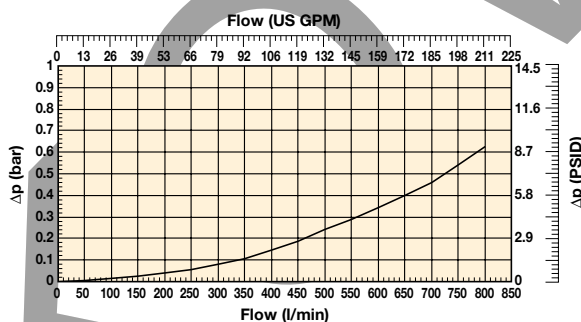

TPR450 (Element length code 10)

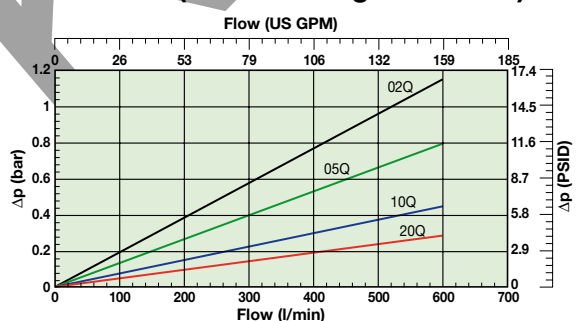

TPR650 (Element length code 11)

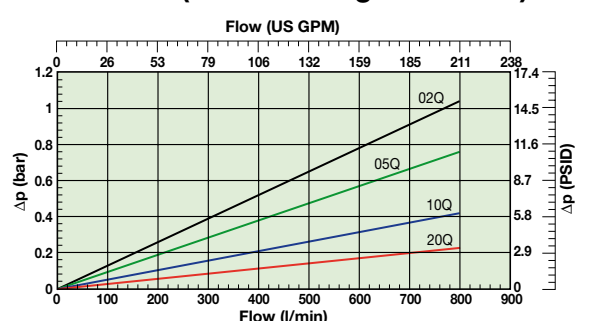

Tanktopper Series I, II & III

Tanktop Mounted Return Line Filters with Integrated Air Breather

Ordering Information

Standard products table

Part number	Supersedes	Flow (l/min)	Model number	Element length	Media rating (µ)	Seals	Indicator	Bypass settings	Ports	Included options	Replacement elements	Supersedes
TPR110QLBP2EG12E	TPR40-G ³ / ₄ PXWL1-10 B15 MM MA	40	TPR40	Length 1	10	Nitrile	Plugged	1.5 Bar (22 Psi)	G ³ / ₄	Magnets	937902Q	PXWL1-10
TPR120QLBP2EG12E	TPR40-G ³ / ₄ PXWL1-20 B15 MM MA	40	TPR40	Length 1	20	Nitrile	Plugged	1.5 Bar (22 Psi)	G ³ / ₄	Magnets	937904Q	PXWL1-20
TPR210QLBP2EG12L	TPR80-G ³ / ₄ PXWL2-10 AB15 MM MA	80	TPR80	Length 2	10	Nitrile	Plugged	1.5 Bar (22 Psi)	G ³ / ₄	Aluminium funnel, magnets	937903Q	PXWL2-10
TPR220QLBP2EG12L	TPR80-G ³ / ₄ PXWL2-20 AB15 MM MA	80	TPR80	Length 2	20	Nitrile	Plugged	1.5 Bar (22 Psi)	G ³ / ₄	Aluminium funnel, magnets	937905Q	PXWL2-20
TPR510QLBP2EG201	TPR120-2G1 ¹ / ₂ PXWL3-10 B15 MM	120	TPR120	Length 5	10	Nitrile	Plugged	1.5 Bar (22 Psi)	2xG1 ¹ / ₂	None	937892Q	PXWL3-10
TPR520QLBP2EG201	TPR120-2G1 ¹ / ₂ PXWL3-20 B15 MM	120	TPR120	Length 5	20	Nitrile	Plugged	1.5 Bar (22 Psi)	2xG1 ¹ / ₂	None	937895Q	PXWL3-20
TPR710QLBP2EG241	TPR250-2G1 ¹ / ₂ PXWL4A-10 B15 MM	250	TPR250	Length 7	10	Nitrile	Plugged	1.5 Bar (22 Psi)	2xG1 ¹ / ₂	None	937894Q	PXWL4A-10
TPR720QLBP2EG241	TPR250-2G1 ¹ / ₂ PXWL4A-20 B15 MM	250	TPR250	Length 7	20	Nitrile	Plugged	1.5 Bar (22 Psi)	2xG1 ¹ / ₂	None	937897Q	PXWL4A-20
TPR1110QLBP2EG241	TPR650-2G1 ¹ / ₂ PXWL8-10 B15 MM	650	TPR650	Length 11	10	Nitrile	Plugged	1.5 Bar (22 Psi)	2xG1 ¹ / ₂	None	937914Q	PXWL8-10
TPR1120QLBP2EG241	TPR650-2G1 ¹ / ₂ PXWL8-20 B15 MM	650	TPR650	Length 11	20	Nitrile	Plugged	1.5 Bar (22 Psi)	2xG1 ¹ / ₂	None	937917Q	PXWL8-20

Note: Filter assemblies ordered from the product configurator below are on extended lead times. Where possible, please make your selection from the table above.

Visual indicator	
Thread connection	G ³ / ₄
Code	FMUG2EBPG02L

Specifications	
Elec.rating	42V / 2A
Thread connection	G ³ / ₄
Elec.connection	AMP terminal 6.3x0.8
Protection	IP65 (terminal IP00)
Switch type	NO or NC
Code	FMUS2EBMG02L (NO switch) FMUS3EBMG02L (NC switch)

Normally open contacts

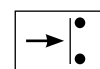

Normally closed contacts

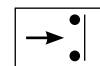

Product configurator

Configurator example TPR filter

Box 1	Box 2	Box 3	Box 4	Box 5	Box 6	Box 7	Box 8
TPR	2	05QL	B	S2	E	G12	L

Box 1	Box 2	Box 3																															
Code	Filter type	Degree of filtration																															
TPR	<table border="1"> <thead> <tr> <th>Housing</th> <th>Code</th> </tr> </thead> <tbody> <tr> <td>TPR 1-40</td> <td>1</td> </tr> <tr> <td>TPR 1-80</td> <td>2</td> </tr> <tr> <td>TPR 2-120</td> <td>5</td> </tr> <tr> <td>TPR 2-200</td> <td>6</td> </tr> <tr> <td>TPR 2-250</td> <td>7</td> </tr> <tr> <td>TPR 3-450</td> <td>10</td> </tr> <tr> <td>TPR 3-650</td> <td>11</td> </tr> </tbody> </table>	Housing	Code	TPR 1-40	1	TPR 1-80	2	TPR 2-120	5	TPR 2-200	6	TPR 2-250	7	TPR 3-450	10	TPR 3-650	11	<table border="1"> <thead> <tr> <th>Element media</th> <th>Glass fibre</th> <th>Wire mesh</th> </tr> </thead> <tbody> <tr> <td rowspan="2">Cellulose</td> <td>Microglass III (for disposable elements)</td> <td rowspan="2">Abs. rating</td> </tr> <tr> <td>Ecoglass III (for LEIF[®] elements)</td> </tr> <tr> <td rowspan="2">Disposable element (TPR I only)</td> <td>Nom. rating</td> <td>Abs. rating</td> </tr> <tr> <td>10C</td> <td>02Q, 05Q, 10Q, 20Q</td> </tr> <tr> <td>LEIF[®] element (for all TPR Filters)</td> <td>02QL, 05QL, 10QL, 20QL</td> <td>040W</td> </tr> </tbody> </table>	Element media	Glass fibre	Wire mesh	Cellulose	Microglass III (for disposable elements)	Abs. rating	Ecoglass III (for LEIF [®] elements)	Disposable element (TPR I only)	Nom. rating	Abs. rating	10C	02Q, 05Q, 10Q , 20Q	LEIF[®] element (for all TPR Filters)	02QL, 05QL , 10QL , 20QL	040W
Housing	Code																																
TPR 1-40	1																																
TPR 1-80	2																																
TPR 2-120	5																																
TPR 2-200	6																																
TPR 2-250	7																																
TPR 3-450	10																																
TPR 3-650	11																																
Element media	Glass fibre	Wire mesh																															
Cellulose	Microglass III (for disposable elements)	Abs. rating																															
	Ecoglass III (for LEIF [®] elements)																																
Disposable element (TPR I only)	Nom. rating	Abs. rating																															
	10C	02Q, 05Q, 10Q , 20Q																															
LEIF[®] element (for all TPR Filters)	02QL, 05QL , 10QL , 20QL	040W																															

Seal type	
Seal material	Code
Nitrile	B
Fluoroelastomer	on request

Indicator	
Pressure gauge, setting 1.2 bar, G ³ / ₄	G2
Pressure switch 42V, 1.2 bar setting, NO with G ³ / ₄	S2
Pressure switch 42V, 1.2 bar setting, NC with G ³ / ₄	S3
Pressure switch 250V, NO/NC with G ³ / ₄	S4
No indicator, indicator ports not machined	on request
No indicator, indicator port R plugged	on request
No indicator, indicator ports L + R plugged	P2
Other settings for indicators / gauges on request	on request

Bypass valve	
Bypass valve	Code
0.8 bar	B
1.5 bar	E
2.5 bar (TPR 1 Series only)	on request
Other bypass settings	on request

Note 1: Part numbers featured with bold highlighted codes will ensure a 'standard' product selection.
Note 2: Alternate displayed part number selection will require you to contact Parker Filtration for availability.

Filter connection	
Ports	Code
G ³ / ₄ (BSP) (TPR 1 Series)	G12
SAE12 (TPR 1 Series)	S12
G1 ¹ / ₂ (BSP) (TPR 2 Series)	G20
2 x ISO 228-G1 ¹ / ₂ (BSP) (TPR 2 Series)	2G20
SAE 20 (TPR 2 Series)	S20
2 x SAE 20 (TPR 2 Series)	2S20
SAE 24 (TPR 2 Series)	S24
2 x SAE 24 (TPR 2 Series)	2S24
G1 ¹ / ₂ (BSP) (TPR 2 and 3 Series)	G24
2 x G1 ¹ / ₂ (BSP) (TPR 2 and 3 Series)	2G24

Options	
Options	Code
Standard	1
Dipstick	6
Aluminium funnel for TPR 1-80	J
Magnets for TPR 1 Series	E
Magnets + Dipstick for TPR 1 Series	K
Magnets + Aluminium Funnel for TPR 80 Series	L
Magnets + Aluminium Funnel + Dipstick for TPR 80 Series	M
Other combinations	on request

Note: Tanktopper I Series are standard supplied with POM type funnel. Aluminium funnel is recommended for heavy duty applications, sensitivity for electrostatically charging or high fluid temperatures. Tanktopper II and III Series are always supplied with metal funnel.

Highlights Key (Denotes part number availability)

123	Item is standard
123	Item is standard green option
123	Item is semi standard
123	Item is non standard

Tanktopper Series I, II & III

Tanktop Mounted Return Line Filters
with Integrated Air Breather

Ordering Information (cont.)

Degree of filtration						Media code
Average filtration beta ratio β (ISO 16889) / particle size μm [c]						
$\beta(x)=2$	$\beta(x)=10$	$\beta(x)=75$	$\beta(x)=100$	$\beta(x)=200$	$\beta(x)=1000$	
% efficiency, based on the above beta ratio (βx)						
50.0%	90.0%	98.7%	99.0%	99.5%	99.9%	
N/A	N/A	N/A	N/A	N/A	4.5	02Q/02QL
N/A	N/A	4.5	5	6	7	05Q/05QL
N/A	6	8.5	9	10	12	10Q/10QL
6	11	17	18	20	22	20Q/20QL

Supersedes spare element table				
TPR 1-40	PXWL1-2	PXWL1-5	PXWL1-10	PXWL1-20
Part number spare element	937898Q	937900Q	937902Q	937904Q
TPR 1-80	PXWL2-2	PXWL2-5	PXWL2-10	PXWL2-20
Part number spare element	937899Q	937901Q	937903Q	937905Q
TPR 2-120	PXWL3-2	PXWL3-5	PXWL3-10	PXWL3-20
Part number spare element	937886Q	937889Q	937892Q	937895Q
TPR 2-200	PXWL4-2	PXWL4-5	PXWL4-10	PXWL4-20
Part number spare element	937887Q	937890Q	937893Q	937896Q
TPR 2-250	PXWL4A-2	PXWL4A-5	PXWL4A-10	PXWL4A-20
Part number spare element	937888Q	937891Q	937894Q	937897Q
TPR 3-250	PXWL6-2	PXWL6-5	PXWL6-10	PXWL6-20
Part number spare element	937906Q	937909Q	937912Q	937915Q
TPR 3-450	PXWL7-2	PXWL7-5	PXWL7-10	PXWL7-20
Part number spare element	937907Q	937910Q	937913Q	937916Q
TPR 3-650	PXWL8-2	PXWL8-5	PXWL8-10	PXWL8-20
Part number spare element	937908Q	937911Q	937914Q	937917Q

Supersedes spare element table						
TPR 1-40	PXX1A-10	PXW1A-2	PXW1A-5	PXW1A-10	PXW1A-20	PS1A-40
Part number spare element	937918	937920Q	937925Q	937930Q	937935Q	937940
TPR 1-80	PXX2A-10	PXW2A-2	PXW2A-5	PXW2A-10	PXW2A-20	PS2A-40
Part number spare element	937919	937921Q	937926Q	937931Q	937936Q	937941
TPR 3-160		PXW5-2	PXW5-5	PXW5-10	PXW5-20	
Part number spare element		937922Q	937927Q	937932Q	937937Q	
TPR 3-250		PXW6-2	PXW6-5	PXW6-10	PXW6-20	
Part number spare element		937923Q	937928Q	937933Q	937938Q	
TPR 3-450		PXW7-2	PXW7-5	PXW7-10	PXW7-20	
Part number spare element		937924Q	937929Q	937934Q	937939Q	

Tank Topper Series Seal Kits	
Part Number	Description
2049010052	NITRILE SEAL KIT TPR1 AG FUNNEL ALU
2049010050	NITRILE SEAL KIT TPR1 AG FUNNEL POM
2049010053	NITRILE SEAL KIT TPR1 NO AG FUNNEL ALU
2049010051	NITRILE SEAL KIT TPR1 NO AG FUNNEL POM
2049010056	NITRILE SEAL KIT TPR2 B
2049010027	NITRILE SEAL KIT TPR3 B
	AG = Air Guide

Suction Return Series

Tanktop Mounted Suction & Return Line
Filters - Types SR1 & SR2
Max. 250 l/min - 10 bar



Filters both open
and closed loop oil
circuits through one
filter

Reduced risk of pump cavitation

SR1 and SR2 are capable of feeding filtered oil under positive pressure to the suction side of the boost pump filtering both open and closed loop oil systems through one filter. Maximum pressure 10 bar. Maximum flow 250 l/min. Use *LEIF*[®] environmentally friendly elements.



Contact Information:

Parker Hannifin
Hydraulic Filter Division Europe

European Product
Information Centre
Freephone: 00800 27 27 5374
(from AT, BE, CH, CZ, DE, EE, ES,
FI, FR, IE, IT, PT, SE, SK, UK)
filtrationinfo@parker.com

www.parker.com/hfde

Product Features:

- SR capable of feeding filtered oil under positive pressure to the suction side of the boost pump.
- Filters both open and closed loop oil systems through one filter.
- Maximum pressure 10 bar. Maximum flow 250 l/min.
- SR uses patented *LEIF*[®] elements to safeguard filtration quality.

Suction Return Series

Tanktop Mounted Suction & Return Line Filters - Types SR1 & SR2

Features & Benefits

Features	Advantages	Benefits
Compact design	Less space required to apply SR Series	Improved flexibility during system design
Bypass valve mounted in series with back-pressure valve	Pressurisation of filtered oil for hydrostatic drive ensured during bypass	Lower risk of pump cavitation
LEIF® elements	Element safeguards the use of genuine parts	No direct bypass in the tank reducing the additional risk of oil foaming
Strainer located in filter head	Element safeguards the use of genuine parts	Guaranteed quality of filtration
High level of customisation	Strainer filters all bypass fluid by using a system-matched degree of filtration	Contributes to ISO 14001 certification
Quick response bypass with low hysteresis	Dedicated system-matched solutions can be easily made available	Improved protection of system
Standard or customised funnel	Reduction of bypass period due to low hysteresis	Strainer can be inspected and cleaned during service events
Multiple ports availability	Only a small part of the total flow is bypassing the element	Improved integration of filter in system combined with lower initial system costs
	Ensures that oil enters the tank under the oil level	Improved protection of system
	Flexibility related to suction- and return line hose(s) arrangement	Significant reduction of oil foaming
		More compact solutions can be realised
		The use of manifold blocks can be avoided
		Easy to integrate with cooler circuit

Typical Applications

Mobile equipment with both open and closed hydraulic circuits. For example:

- Road sweepers
- Road rollers
- Fork lift trucks
- Loading shovels
- Telescopic handlers
- Dump trucks
- Skid steers
- Agricultural harvesting machines
- Mini excavators

The Parker Filtration Tank Top Mounted Suction & Return Line Filters.

A tank top mounted return filter capable of feeding filtered oil under positive pressure to the suction side of the boost pump, thereby filtering both open and closed loop oil systems through one filter. The Parker SR filters use the LEIF® element for environmental-friendly filtration and offers protection against the use of pirate elements. Several options including integrated suction strainer and dipstick are available.

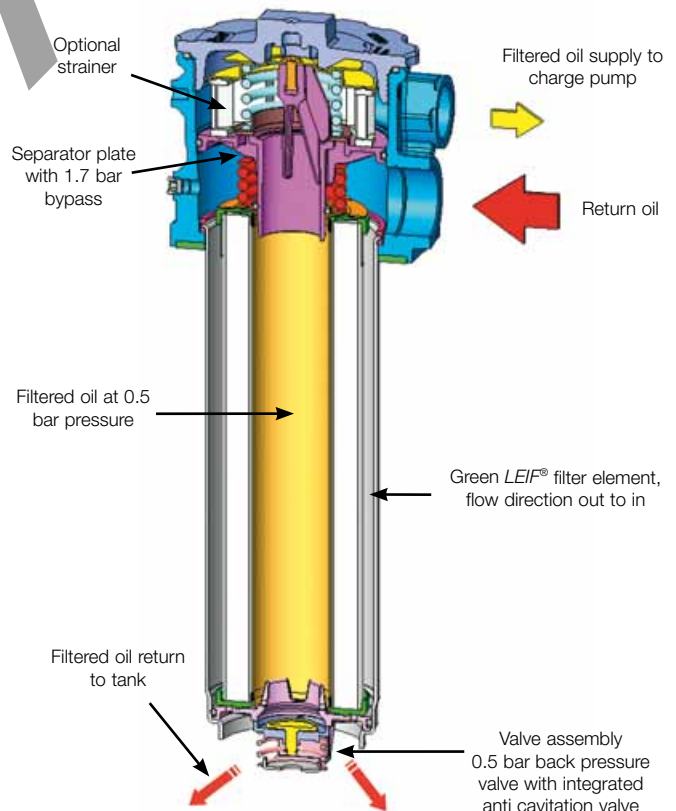

Specification

Pressure ratings:

Max. 10 bar.

Assembly:

Tank top mounted filters.

Connections:

Return port G1 (to BS 2779).

Suction port G³/₄ (to BS 2779).

} SR1

Return port G1¹/₄ (ISO 228) or SAE20:

Optional second return port type SR2.

Suction port G1 (ISO 228) or SAE16:

Standard two suction ports.

} SR2

Seal material:

Type SR1 – Nitrile.

Type SR2 – Nitrile, Fluoroelastomer.

Other seal material on request.

Operating temperature range:

-30° to +110°C.

Bypass valve system:

Main system bypass valve.

Type SR1 – 1.7 bar (2.5 bar optional).

Type SR2 – 1.7 bar (2.5 bar optional).

Degree of filtration:

Determined by multipass test according to ISO 16889.

Flow fatigue characteristics:

Filter media designed to optimise fatigue life.

Filtration media:

Type SR1 and SR2 –

Ecoglass III for *LEIF*[®] elements. See 'degree of filtration' table on the Ordering Information page.

- High dirt holding capacity.

- Low pressure drop.

- Extended service life.

Element collapse rating:

Type SR1 – 10 bar (ISO2941).

Type SR2 – 10 bar (ISO2941).

Suction line:

Back-pressure valve setting 0.5 bar (nominal).

Anti-cavitation:

Emergency suction valve fitted as standard.

Construction:

Type SR1 and Type SR2

Filter Housing: Precision pressure die casting

Cover:

Glass reinforced nylon (high impact and temperature resistant)

Weight:

1.4Kg 3.3Kg

Filter element:

LEIF[®] element with reusable metal element sleeve.

element:

The patented *LEIF*[®] concept contributes to ISO14001 } SR1 and can be applied with mineral and HEES type fluids. } & SR2 For other fluid types consult Parker Filtration.

Circuit Application Example

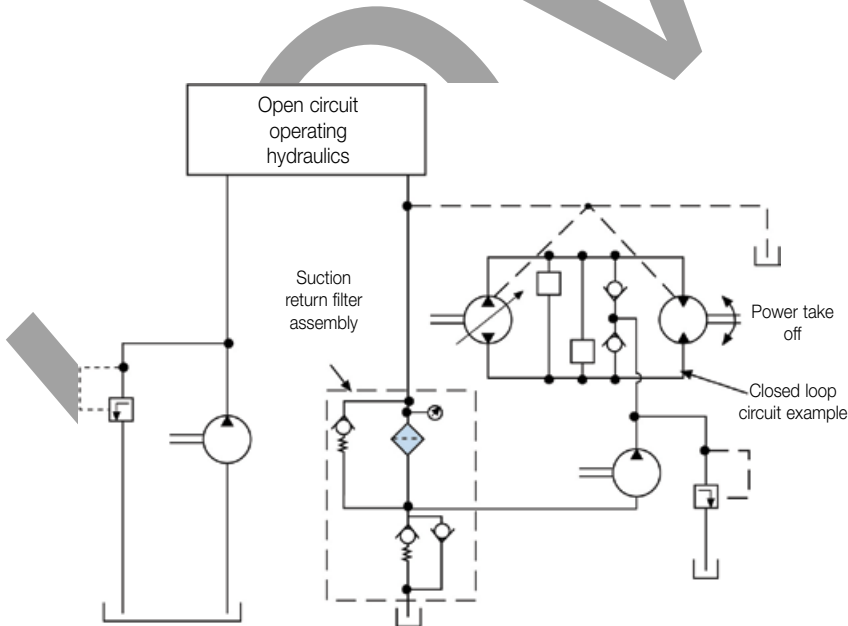

Note: Suction return filter without optional strainer.

Suction Return Filter: Hydraulic Circuit

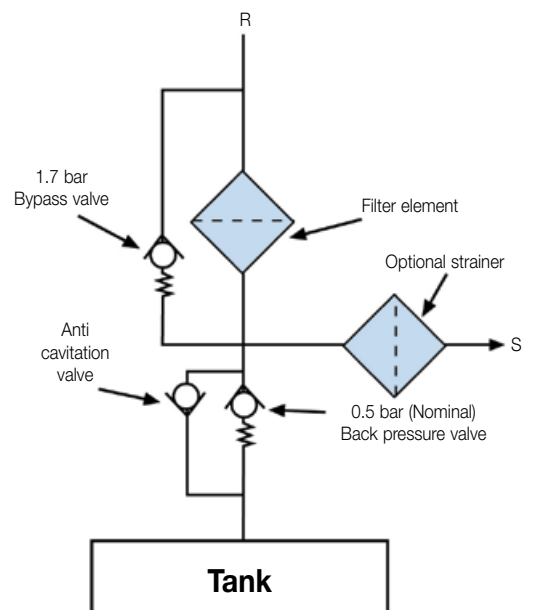

Note: Suction return filter with optional strainer.

Suction Return Series

Tanktop Mounted Suction & Return Line Filters - Types SR1 & SR2

SR1

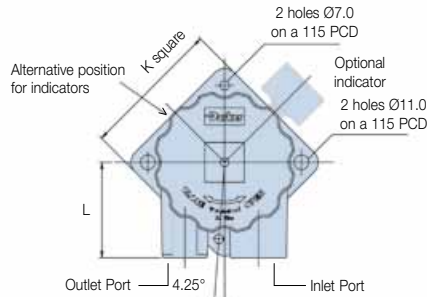
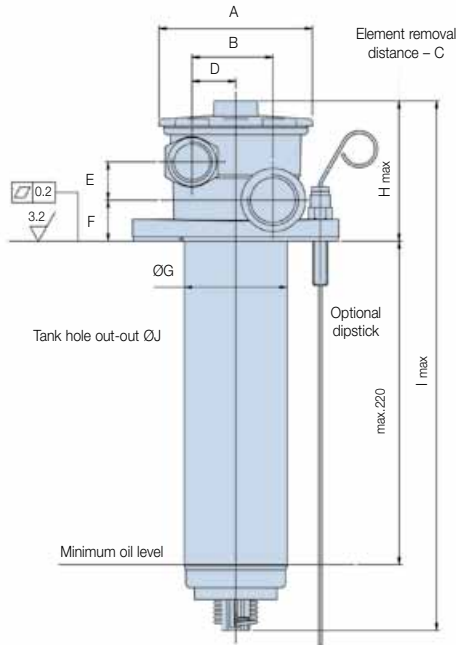

SR2

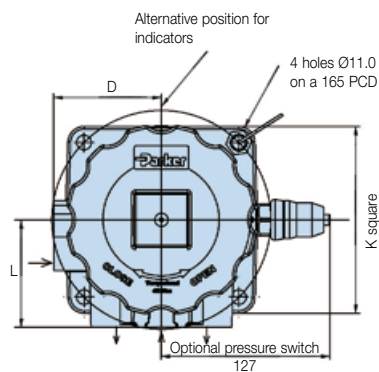
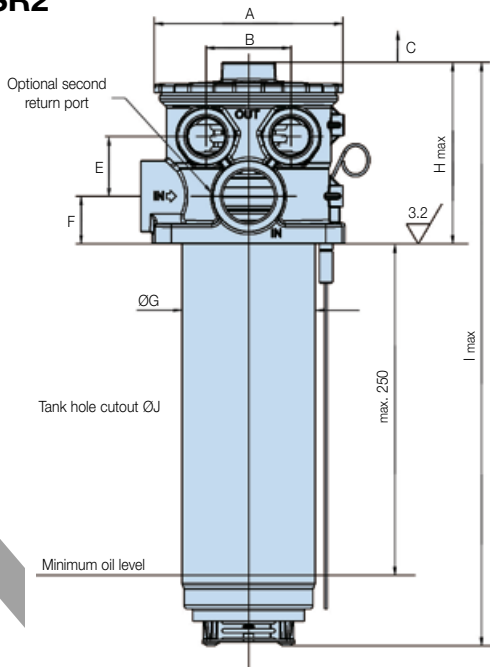

Dimensions mm (inches)	A	B	C	D	E	F	G	H	I	J	K	L
Type SRL1	106 (4.17)	55 (2.17)	280 (11.0)	29.75 (1.17)	26 (1.02)	28 (1.10)	70 (2.76)	96 (3.78)	361 (14.21)	71 to 73 (2.8 to 2.87)	105 (4.13)	72 (2.83)
Type SRL2	142 (5.59)	64 (2.52)	380 (14.96)	81 (3.19)	45 (1.77)	36 (1.42)	100 (3.94)	137 (5.39)	440 (17.32)	101 to 103 (3.98 to 4.06)	145 (5.71)	81 (3.19)

Element removal distance for dimension C.



Indicator Details

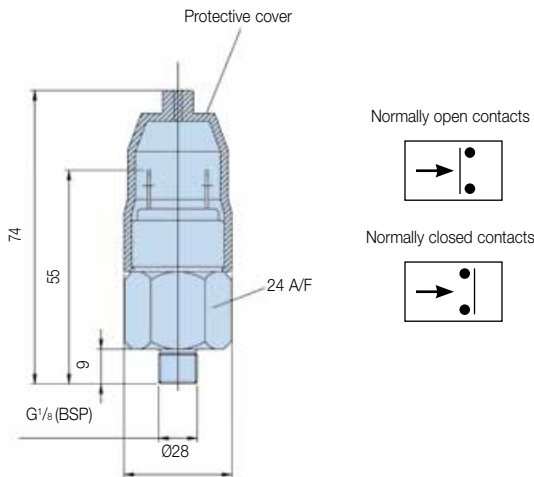

Visual Indicator	
Setting	2 bar
Thread connection	G ¹ / ₈
Code	FMUG5HBMG02L

Pressure switch	
Elec.rating	42V / 2A
Thread connection	G ¹ / ₈
Elec.connection	AMP terminal 6.3 x 0.8
Protection	IP65 (terminal IP00)
Setting	2 bar
Switch type	NO or NC
Code	FMUS6HBMG02L (NO switch) FMUS7HBMG02L (NC switch)

Note: Vacuum indicators visual or electrical are available on request for filter type SR2 only.

Principles of Operation

Suction Return Series filter

This one filter assembly is designed to carry out two specific functions:

- (1) Filter system return line oil.
- (2) Supply filtered oil under positive pressure to the closed loop hydrostatic circuits.

Principles of operation

- (1) Return oil from both the open and closed circuits* is fed into the Suction Return Series Filter at port 'R'.
- (2) The filtered oil is maintained at a nominal 0.5 bar by the unique back pressure valve assembly and fed into the closed loop hydrostatic circuit via port 'S'.
- (3) Surplus filtered oil is fed back to the tank via the back pressure valve assembly.
- (4) Emergency suction (anti-cavitation) valve: This valve is fitted as standard to ensure oil is always available to the closed loop system, even on emergency occasions when the return flows do not meet the flow demands of the closed loop circuit.

Additional installation guidance notes

- (1) Return oil flow should always be greater than the oil flow rate demanded by the closed loop charge pump.
- (2) Oil level at all times should not fall below valve assembly at the base of the filter bowl.

Benefits

- (1) Only one filter is required to supply filtered oil to both open and closed loop circuits.
- (2) Feeding the closed loop circuit with filtered oil at a nominal pressure of 0.5 bar ensures excellent cold start characteristics, thus reducing the risk of cavitation.
- (3) Four hole mounting with gasket seal.
- (4) Microglass III filter element materials ensure; low pressure drop, high dirt holding capacity and extended service life.
- (5) Type Parker SR filters with patented LEIF[®] element, unique drain construction, quick element replacement concept.

*CAUTION:

Back pressure in pump and motor drain lines should always be kept at a minimum thus protecting shaft seals etc.

If case drain oils are to be fed through the return line filter please consult the pump/motor manufactures for details on maximum allowable back pressure.

Ensure filter elements are replaced when element condition indicators show that the bypass setting has been reached.

Failure to observe the above operation and guidance notes, or use of non genuine Parker specified filter elements could cause damage to the system. System designers should always ensure that adequate cooling capacity is available.

Suction Return Series

Tanktop Mounted Suction & Return Line Filters - Types SR1 & SR2

Pressure Drop Curves (Type SR1)

The recommended level of the initial pressure drop is approximately 1 bar.
 If the medium used has a viscosity different from 32cSt, pressure drop over the filter can be estimated as follows:
 The total $\Delta p = \text{Housing } \Delta p_h + (\text{Element } \Delta p_e \times \text{working viscosity}/32)$.

SRL1 Empty Housing (Length Code 2)

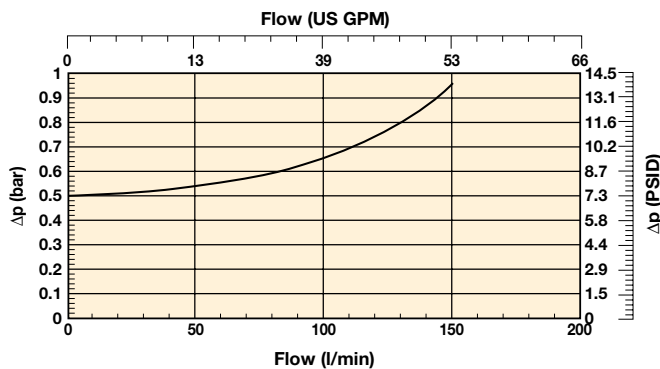

SRL1 (Element Length Code 2)

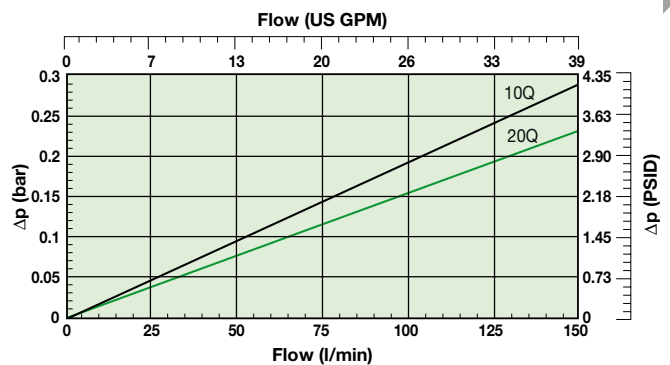

Curves are based on 32cSt fluid viscosity and 0.87 Kg/l density.
 Line represents the Δp of the housing including the back pressure valve.

Pressure Drop Curves (Type SR2)

Curves are based on 32cSt fluid viscosity and 0.87 Kg/l density.

SRL2 Empty Filter Housing

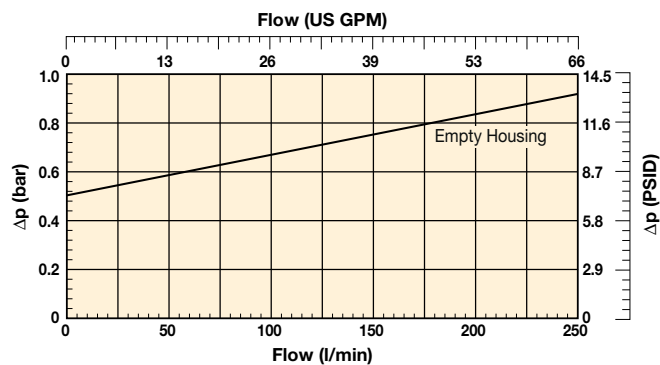

SRL2 Filter Element Length 2

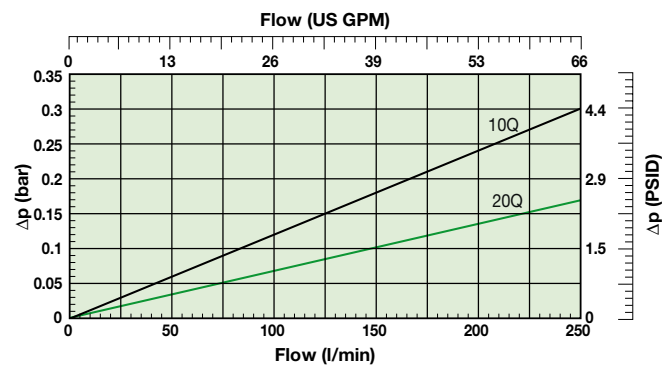

Line represents the Δp of the housing including the back pressure valve.

Ordering Information

Standard products table

Part number	Supersedes	Flow (l/min)	Model number	Element length	Media rating (µ)	Seals	Indicator	Bypass settings	Ports return	Ports suction	Included options	Replacement elements	Supersedes
SRL1210QLBPGG161		130	SRL1	Length 2	10	Nitrile	Plugged	1.7 Bar (25 Psi)	G1	G ¹ / ₄	None	937984Q	SRE12Q10
SRL1220QLBPGG161		130	SRL1	Length 2	20	Nitrile	Plugged	1.7 Bar (25 Psi)	G1	G ¹ / ₄	None	937985Q	SRE12Q20
SRL2210QLBPGG201	SRL22Q10NP1B10	250	SRL2	Length 2	10	Nitrile	Plugged	1.7 Bar (25 Psi)	G1 ¹ / ₄	2xG1	None	937946Q	SRE22Q10
SRL2220QLBPGG201	SRL22Q20NP1B10	250	SRL2	Length 2	20	Nitrile	Plugged	1.7 Bar (25 Psi)	G1 ¹ / ₄	2xG1	None	937947Q	SRE22Q20

Note: Filter assemblies ordered from the product configurator below are on extended lead times. Where possible, please make your selection from the table above.

Product configurator

Configurator example SR filter

Box 1	Box 2	Box 3	Box 4	Box 5	Box 6	Box 7	Box 8
SRL2	2	05QL	B	S6	G	2G20	I

Box 1

Code	
Model	Code
SR1 Series with LEIF [®] element	SRL1
SR2 Series with LEIF [®] element	SRL2

Highlights Key (Denotes part number availability)

123	Item is standard
123	Item is standard green option
123	Item is semi standard
123	Item is non standard

Box 2

Filter type	
Housing	Code
Reduced length	on request
Standard length	2
Extended length	on request

Box 3

Degree of filtration				
Element	LEIF [®]			
	Q3 glassfibre βx(c) >200			
	Code	Code	Code	Code
LEIF [®]	02QL	05QL	10QL	20QL

Box 4

Seal type	
Seal material	Code
Nitrile	B
Fluoroelastomer	V

Box 5

Indicator	
	Code
Pressure gauge, setting 2.0 bar, G ¹ / ₄	G5
Pressure switch 42V, 2.0 bar setting, NO with G ¹ / ₄ BSP	S6
Pressure switch 42V, 2.0 bar setting, NC with G ¹ / ₄ BSP	S7
Pressure switch 250V, NO/NC with G ¹ / ₄	on request
No indicator, indicator port L + R plugged	P
Vacuum switch / vacuum gauge	on request
Other settings for indicators / gauges on request	on request

Box 6

Bypass valve	
Bypass valve	Code
1.7 bar	G
2.5 bar	I
Blocked bypass	on request
Other bypass settings	on request

Box 7

Filter connection		
Ports	Code	Note
Return port 1 x G1 (ISO228) + Suction port 1 x G ¹ / ₄ (ISO228)	G16	SRL1
Return port 1 x G1 ¹ / ₄ (ISO228) + Suction port 2 x G1 (ISO228)	G20	SRL2
Return port 2 x G1 ¹ / ₄ (ISO228) + Suction port 2 x G1 (ISO228)	2G20	SRL2
Return port 1 x SAE20 + Suction port 2 x SAE16	S20	SRL2
Return port 2 x SAE20 + Suction port 2 x SAE16	2S20	SRL2

Box 8

Options	
Options	Code
None	1
Strainer 120 micron	G
Dipstick	6
Plugged vent port in cover (on request)	on request
Strainer 120 micron, dipstick and plugged vent port	I
Customized options	on request

Degree of filtration						Media code
Average filtration beta ratio β (ISO 16889) / particle size µm [c]						
βx(c)=2	βx(c)=10	βx(c)=75	βx(c)=100	βx(c)=200	βx(c)=1000	
% efficiency, based on the above beta ratio (βx)						
50.0%	90.0%	98.7%	99.0%	99.5%	99.9%	02Q/02QL
N/A	N/A	N/A	N/A	N/A	4.5	05Q/05QL
N/A	N/A	4.5	5	6	7	10Q/10QL
N/A	6	8.5	9	10	12	20Q/20QL
6	11	17	18	20	22	

Spare elements		
Replacement elements	Supersedes	
937942Q	SRR12Q05N	Semi standard
937943Q	SRR12Q10N	Standard
937944Q	SRR12Q20N	Standard
937945Q	SRE22Q05	Semi standard
937946Q	SRE22Q10	Standard
937947Q	SRE22Q20	Standard
937983Q	SRE12Q05	Semi standard
937984Q	SRE12Q10	Standard
937985Q	SRE12Q20	Standard

Note 1: Part numbers featured with bold highlighted codes will ensure a 'standard' product selection.

Note 2: Alternate displayed part number selection will require you to contact Parker Filtration for availability.

Suction Return - Series Seal Kits	
Part Number	Description
2049010065	NITRILE SEAL KIT SRL1
2049010061	NITRILE SEAL KIT SRL2



Maxiflow Series

Spin-on Filters

Max. 360 l/min - 10 bar



Designed for both suction and return application

Spin-on filters

The Maxiflow Series full flow filters for suction or return are designed to provide quality protection for hydraulic or lubrication systems.

Rated at a maximum pressure of 10 bar at 360 l/min, Maxiflow filters cover a wide range of mobile and industrial applications.



Contact Information:

Parker Hannifin
Hydraulic Filter Division Europe

**European Product
Information Centre**
Freephone: 00800 27 27 5374
(from AT, BE, CH, CZ, DE, EE, ES,
FI, FR, IE, IT, PT, SE, SK, UK)
filtrationinfo@parker.com

www.parker.com/hfde

Product Features:

- Maxiflow full flow filters for suction or return applications.
- Available with optional indicators.
- Maximum pressure 10 bar. Maximum flow 360 l/min.
- High quality filter medium.



Maxiflow Series

Spin-on Filters

Max. 360 l/min - 10 bar

Features & Benefits

Features	Advantages	Benefits
High quality paint for canisters	Long term protection against corrosion	Better protection against environmental influences
Spin-on filters available for suction and return line filtration	Flexible product offering	Standardisation of components
High quality filter medium	Filter medium suitable for fatigue load due to high frequent flow fluctuation	Extended element life time

Typical Applications

- Telescopic handlers
- Refuse vehicles
- Road sweepers
- Compactors
- Industrial power units
- Grass cutters
- Press brakes



MXA 1 Series



MXA 2 Series



MXA 3 Series

The Parker Filtration Maxiflow Full Flow Filters for Suction or Return.

Maxiflow filters are ideally suited to full flow and bypass circuit installations where the need for high quality filter media is recommended for effective protection of system components, improving system productivity and profitability.

Optional indicators provide direct information as to when the spin-on canisters require replacement.

Specification

Maximum working pressure:	MXA Series 10 bar
Filter head material:	Aluminium alloy
Filter bowl material:	Steel
Seal material:	Nitrile
Operating temperature range:	-30°C to +100°C
Bypass:	Return line 1.7 bar Suction line 0.2 bar No bypass option
Fluids:	Mineral oils
Element media:	Microglass III media Cellulose media

Installation Details

MXA 1 Series

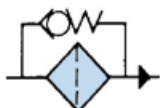
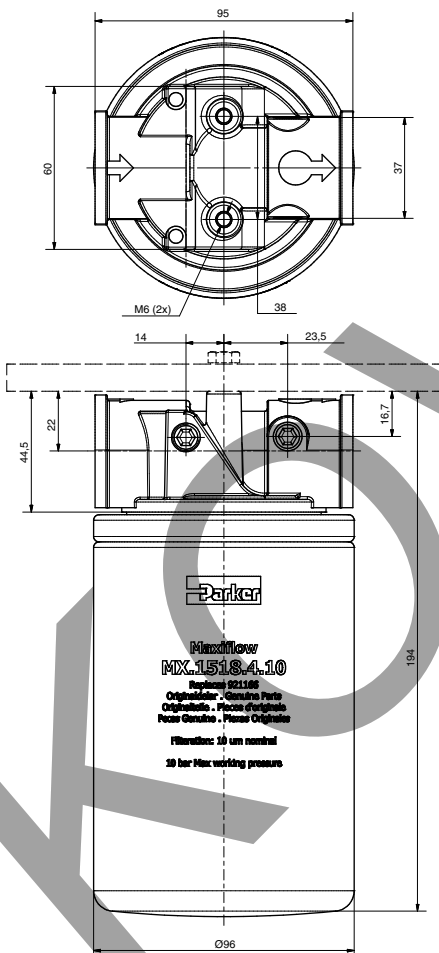

MXA 2 Series

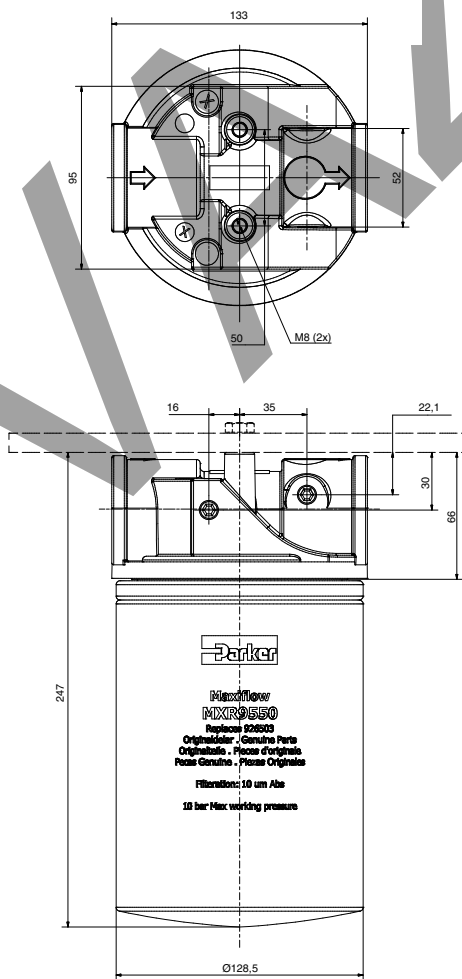

MXA 3 Series

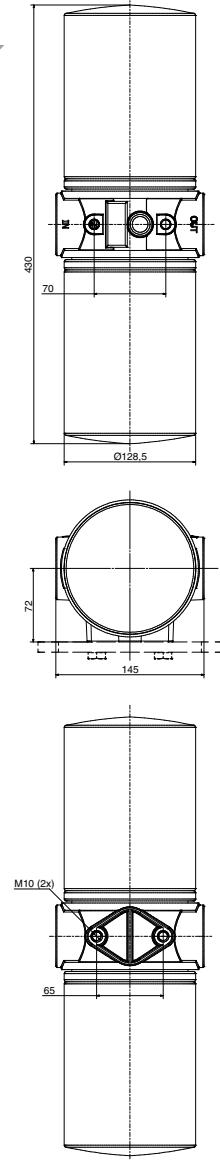

Maxiflow Series

Pressure Drop Curves

The recommended level of the initial pressure drop for low pressure filters is max 0.5 bar.
 If the medium used has a viscosity different from 30cSt, pressure drop over the filter can be estimated as follows:
 $\Delta p = (\Delta p_{30} \times \text{viscosity of medium used}) / 30\text{cSt}$.

Maxiflow MXA 1 Series

Filter Housing

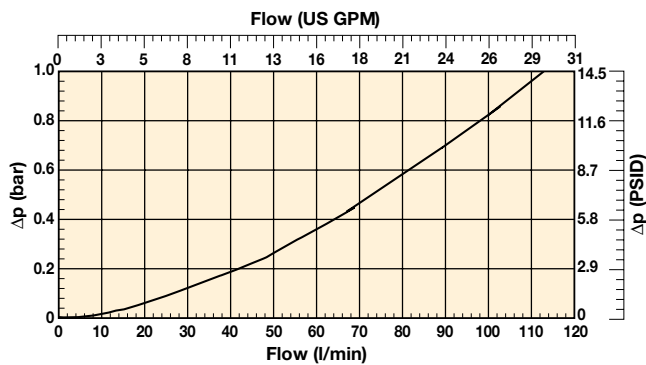

Filter Element

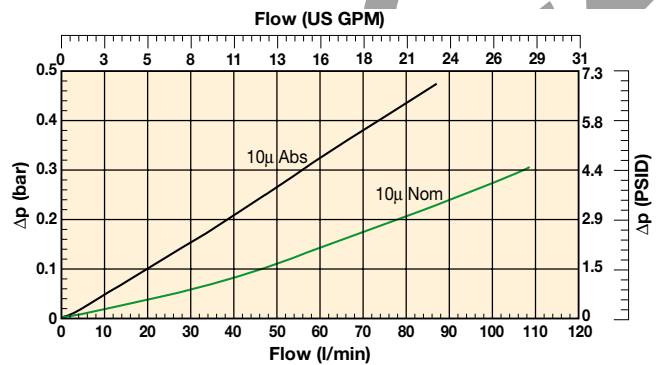

Maxiflow MXA 2 Series

Filter Housing

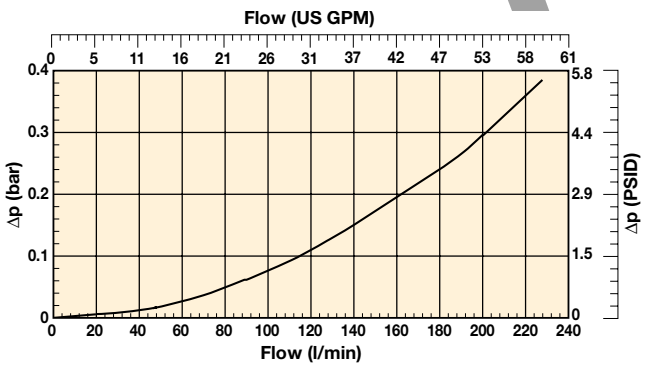

Filter Element

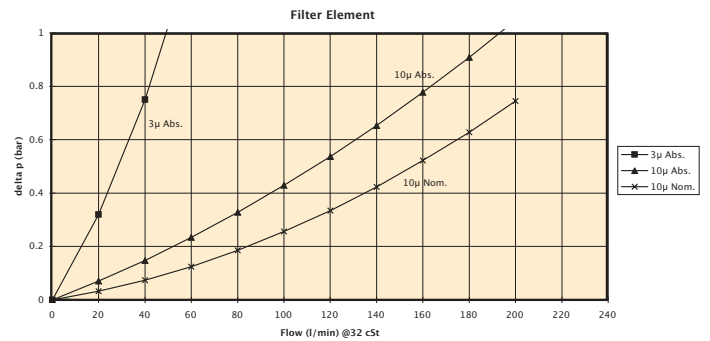

Maxiflow MXA 3 Series

Filter Housing

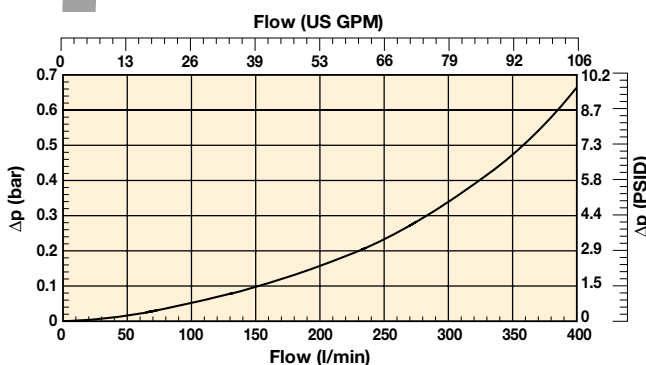

Filter Element

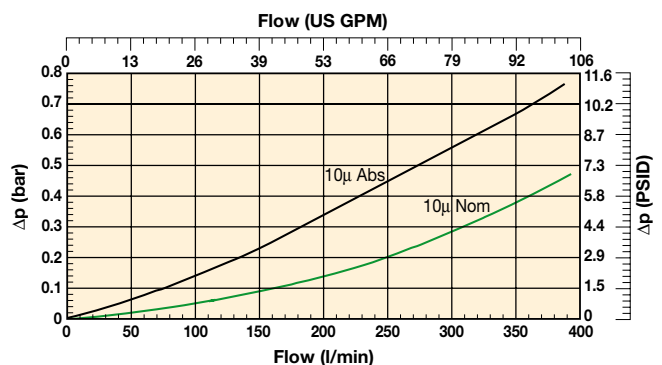

Note: All above data is calculated at 30cSt Rel density 0.856.

Indicator Specifications

Option

Visual Pressure Indicator
Code G2

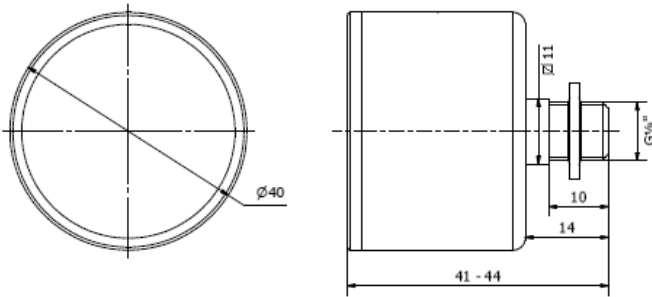

Visual indicator	
Thread connection	G1/8
Code	FMUG2EBPG02L

Option

Indicator PS NO/NC Pressure Switch
Code S2/S3

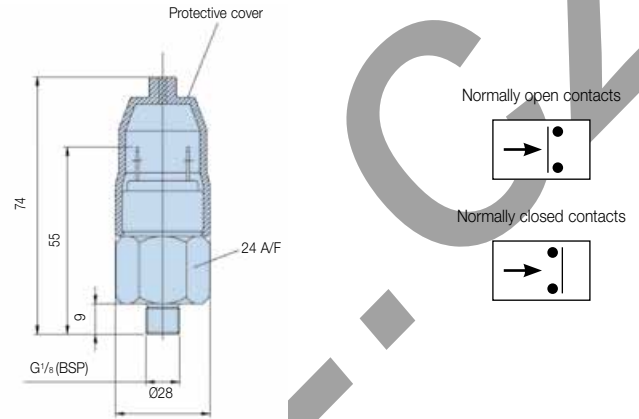

Specifications	
Elec.rating	42V / 2A
Thread connection	G1/8
Elec.connection	AMP terminal 6.3x0.8
Protection	IP65 (terminal IP00)
Switch type	NO or NC
Code	FMUS2EBMG02L (NO switch) FMUS3EBMG02L (NC switch)

Ordering Information

Box 1

Housing type	Code
MXA1	MXA1
MXA2	MXA2
MXA3 Double element version	MXA3

Box 2

Element Length	Dimensions	Thread Spin-on can	Code
Short (MXA 1 only)	D=97.0 L=58.5	G3/4"	On request
Size 1 (MXA 1 only)	D=97.0 L=145	G3/4"	2
Size 2 (Not for MXA1)	D=128.0 L=180	G1 1/4"	3
Ext'd Size 2 (Not for MXA1)	D=128.0 L=226	G1 1/4"	On request

Box 3

Filter Media	Code
10 micron Microglass III Abs.	10Q
10 micron (nom) Cellulose	10C
3 micron Abs. (MXA2 + 3 only)	03Q

Box 4

Seal Material	Code
Nitrile	B

Box 5

Indicator	Code
Plugged port	P
Pressure Switch 42V, 1.2 bar setting, NO	S2
Pressure Switch 42V, 1.2 bar setting, NC	S3
Pressure Gauge, setting 1.2 bar	G2

Box 6

Bypass Valve	Code
1.7 bar	G
Blocked Bypass	X
0.2 bar Suction	On request

Box 7

Ports	Code
G3/4" (MXA1 only)	G12
G1 1/4" (MXA2 only)	G20
G1 1/2" (MXA3 only)	G24

Box 8

Housing type	Code
Standard	1

ATZ Series

Suction Filters

Max. 300 l/min



When the ultimate protection is critical

Compact and robust cast aluminium filter design

The ATZ Series locate below tank oil level offering maximum protection for the hydraulic system pump. Pre-filtration takes place by means of a magnetic column. Maximum flow 300 l/min. Suitable for heavy duty industrial applications and recommended for reservoirs with high contamination ingress.



Contact Information:

Parker Hannifin
Hydraulic Filter Division Europe

**European Product
Information Centre**
Freephone: 00800 27 27 5374
(from AT, BE, CH, CZ, DE, EE, ES,
FI, FR, IE, IT, PT, SE, SK, UK)
filtrationinfo@parker.com

www.parker.com/hfde

Product Features:

- ATZ submersible suction filters locate below tank oil level.
- Pre-filtration takes place by means of a magnetic column.
- Maximum flow 300 l/min.
- In-to-Out filter stops contaminated oil leaking back into the system.

ATZ Series

Suction Filters

Features & Benefits

Features	Advantages	Benefits
Cast aluminium construction	Compact and robust durable construction	Suitable for heavy duty industrial applications
Integrated check valve	Filter element can be changed when the filter housing is submerged under the oil in the tank	Improved protection of sophisticated pumps
Magnetic pre-filtration	Removes ferrous particles, even during bypass conditions	Improved fluid cleanliness levels Extended element life time
In-to-Out filtration	All captured contamination retains inside the element	No recontamination of system during change of elements
Wide range of vacuum measurement devices	Continuous filter condition monitoring	Contributes to just-in-time service Improved protection of pump when pressure measurement device connected with pump drive management

Typical Applications

- Wool untangling machine
- Hydraulic winch
- Power packs with sophisticated pumps
- Drilling blocks

The Parker Filtration ATZ Series Submersible Suction Filters.

ATZ Filters are located below the tank's oil level, offering maximum protection for the hydraulic system pump. When removing the element, the check valve closes automatically, eliminating any chance of oil leakage. Pre-filtration takes place by means of a magnet column. Thanks to the 'In-to-Out' filter principle, contaminated oil cannot leak back into the system. ATZ Filters are capable of handling nominal flow rates up to 300 l/min.



Specification

Operating pressure:
Vacuum.

Assembly:
Suction line filter, mounted horizontally against tank side.

Connections:
Threads G1 $\frac{1}{2}$ (ISO 228) or flanges 2" SAE-300PSI.

Filter housing:
Aluminium.

Seal material:
Nitrile, neoprene, fluoroelastomer.

Operating temperature range:
Seal material Nitrile: -40° to +100°C.
Seal material Fluoroelastomer: -20° to +130°C.

Bypass valve:
Blocked.

Degree of filtration:
Determined by multipass test according to ISO 16889.

Flow fatigue characteristics:
Filter media is supported so that the optimal fatigue life is achieved.

Filtration media:
Microglass III.
10 μ cellulose and 40 μ Stainless Steel.

Element burst+ rating:
10 bar (ISO 2941).

Pressure indicator options:
0.15 bar or 0.30 bar (vacuum gauge).
125-250VAC (LI-0, 5A, Lr-2, 0A) (electrical vacuum switch).
12-28Vdc (Li-1, 0A, Lr-3, 0A) (electrical vacuum switch).

Features:
Unique check valve, enabling element change below oil level.

Filter element:
Element with steel end caps.

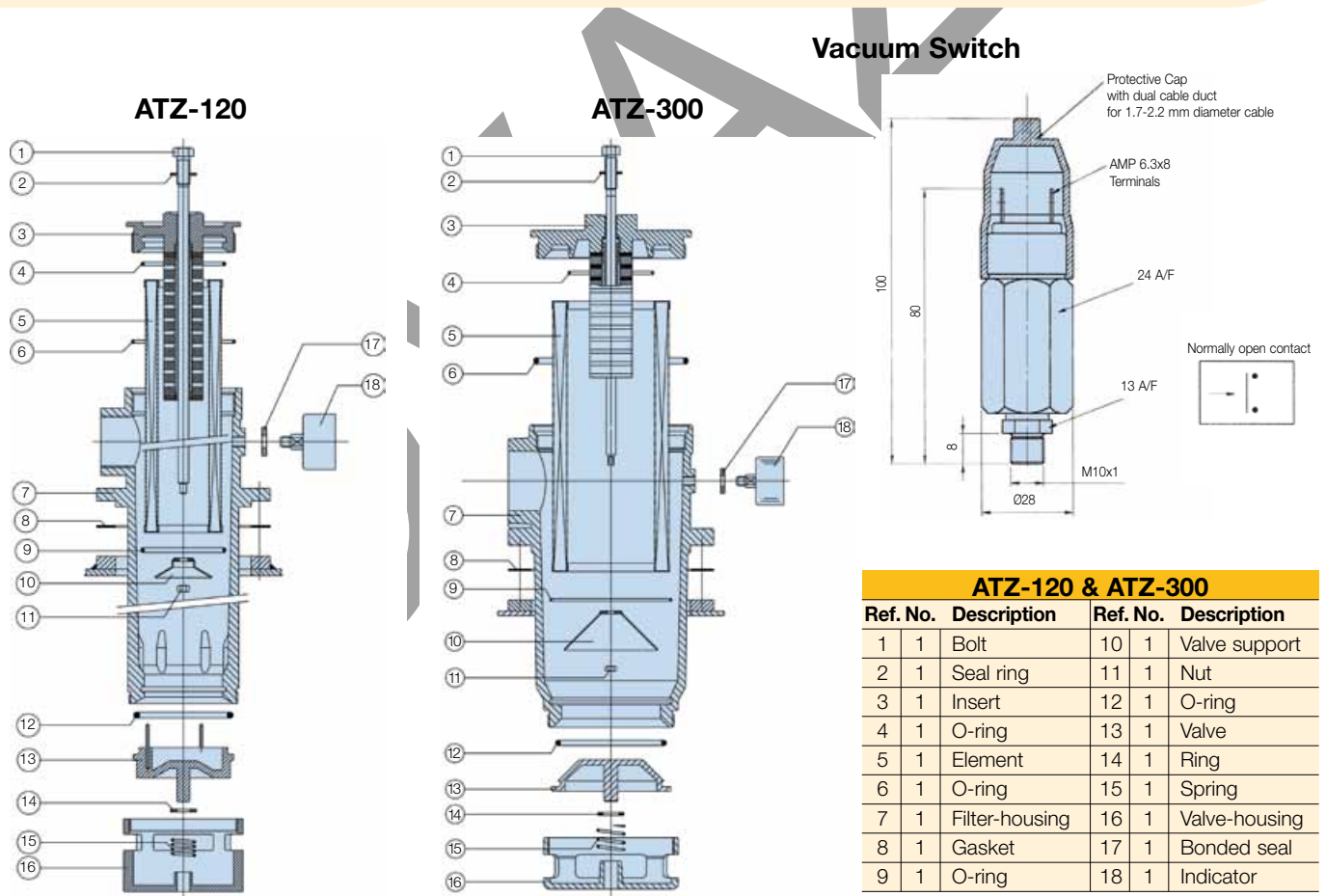

ATZ-120 & ATZ-300			
Ref. No.	Description	Ref. No.	Description
1	1 Bolt	10	1 Valve support
2	1 Seal ring	11	1 Nut
3	1 Insert	12	1 O-ring
4	1 O-ring	13	1 Valve
5	1 Element	14	1 Ring
6	1 O-ring	15	1 Spring
7	1 Filter-housing	16	1 Valve-housing
8	1 Gasket	17	1 Bonded seal
9	1 O-ring	18	1 Indicator

ATZ Series

Suction Filters

Specification (cont.)

ATZ-120

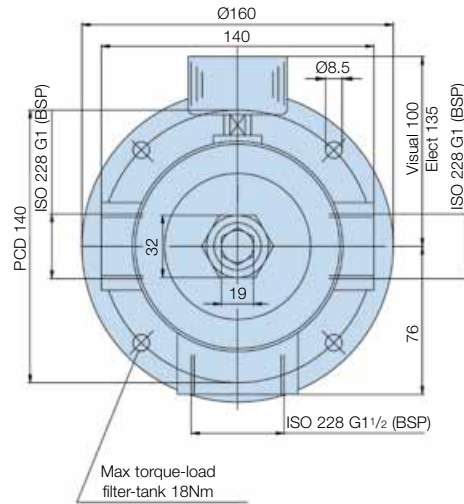
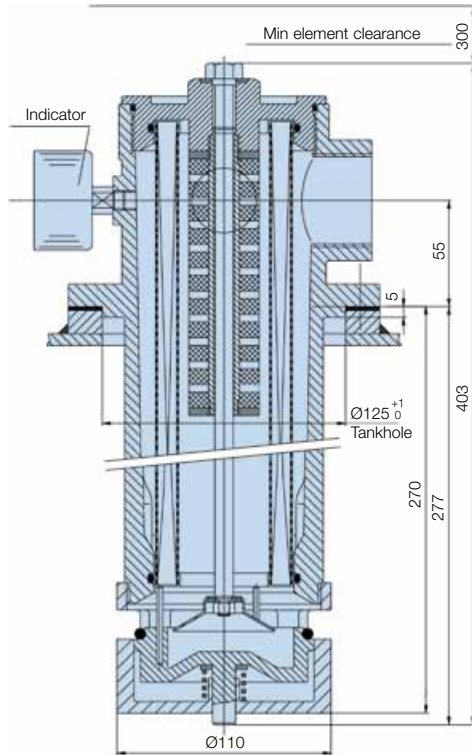

The Parker suction filters, type ATZ, are designed for submerged operation. The filters contain a unique check valve which automatically closes when the filter insert is removed from the housing, thus enabling element change below oil level. Construction is based on the field proven Parker Filter System.

ATZ-300

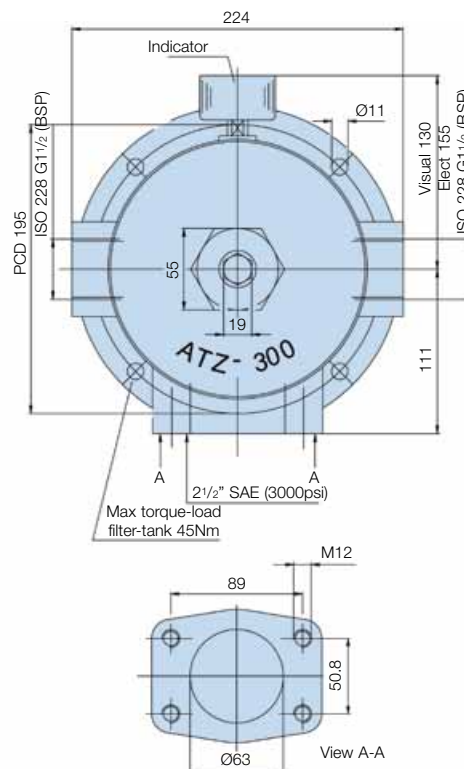
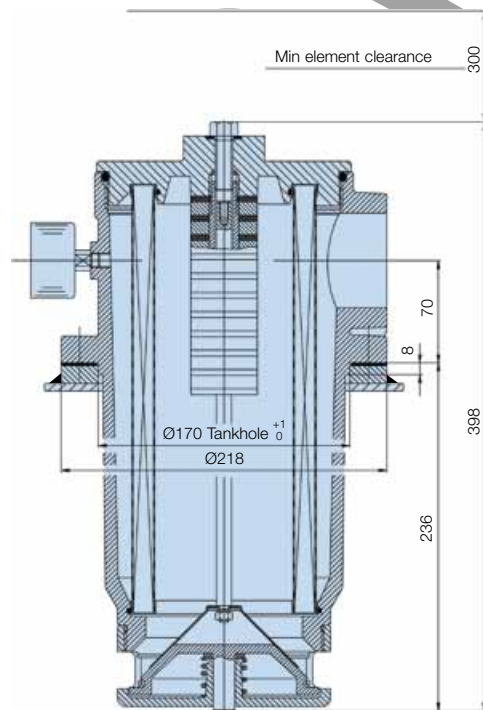

Pressure Drop Curves

The recommended level of the initial pressure drop for suction filters is 0.03 bar.

If the medium used has a viscosity different from 32cSt, pressure drop over the filter can be estimated as follows:

$$\Delta p = (\Delta p_{32} \times \text{viscosity of medium used}) / 32\text{cSt}$$

Filter housing and element pressure drop based on 32cSt fluid viscosity and 0.87 density.

ATZ 1-120 (G1^{1/2}) Empty Housing

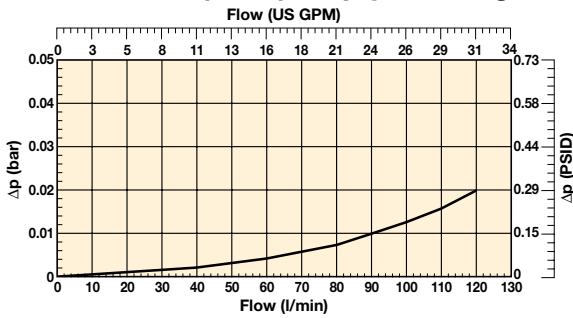

ATZ 300 (2^{1/2} SAE FLANGE) Empty Housing

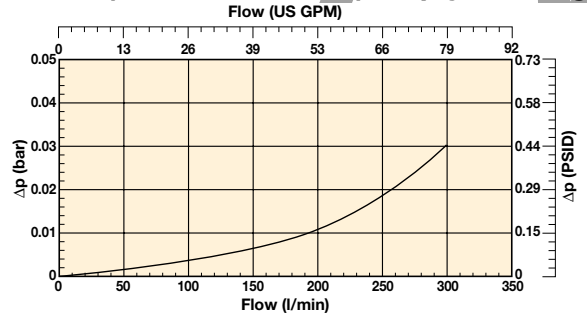

ATZ120 Filter Element Length 1

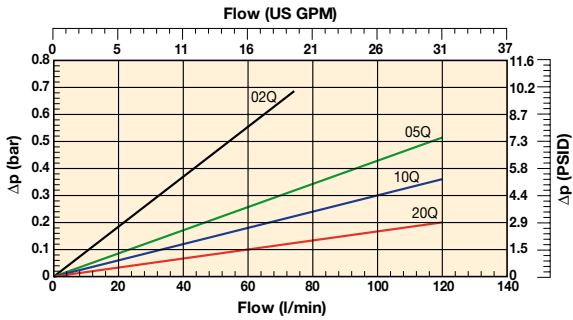

ATZ300 Filter Element Length 2

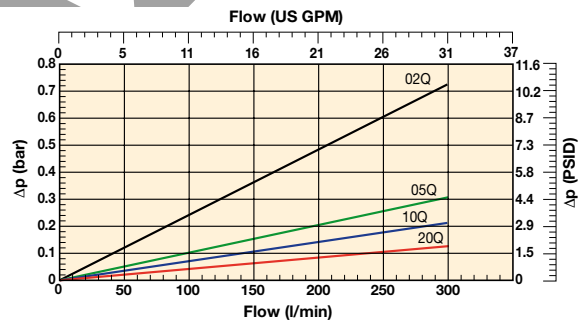

ATZ120 Filter Element Length 1 (cellulose and stainless steel)

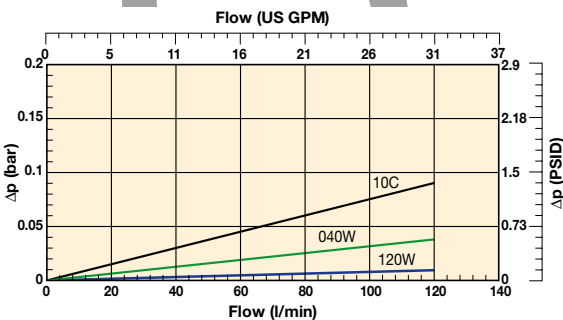

ATZ300 Filter Element Length 2 (cellulose and stainless steel)

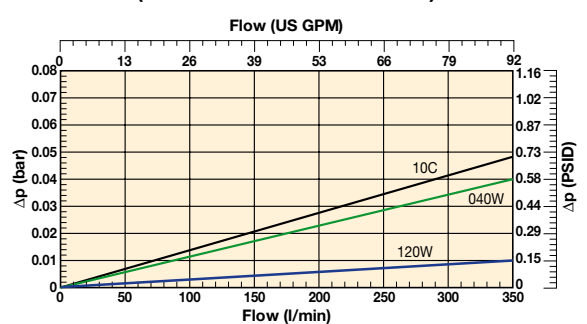

ATZ Series

Suction Filters

Ordering Information

Standard products table

Part number	Supersedes	Flow (l/min)	Model number	Element length	Media rating (µ)	Seals	Indicator	Bypass settings	Ports	Included options	Replacement elements	Supersedes
ATZ110CBPXG241	ATZ120-G1½ FXW1-R-10 B M	120	ATZ120	Length 1	10 NOM	Nitrile	Plugged	Blocked	G1½"	None	937958	FXW1-R-10
ATZ110QBXPXG241	ATZ120-G1½ FXW1-R-10 B M	120	ATZ120	Length 1	10 ABS	Nitrile	Plugged	Blocked	G1½"	None	937964Q	FXW1-R-10
ATZ210CBPXR481	ATZ300-S2½-C FXW3-10 B M	300	ATZ300	Length 2	10 NOM	Nitrile	Plugged	Blocked	2½" SAE-3000 PSI	None	937959	FXW3-10
ATZ210QBXPXR481	ATZ300-S2½-C FXW3-10 B M	300	ATZ300	Length 2	10 ABS	Nitrile	Plugged	Blocked	2½" SAE-3000 PSI	None	937965Q	FXW3-10

Note: Filter assemblies ordered from the product configurator below are on extended lead times. Where possible, please make your selection from the table above.

Product configurator

Configurator example ATZ filter

Box 1	Box 2	Box 3	Box 4	Box 5	Box 6	Box 7	Box 8
ATZ	2	10C	B	U2	X	R48	1

Box 1	Box 2	Box 3
Code	Filter type	Degree of filtration
ATZ	Housing	Element media
	Code	Glass fibre
	ATZ 1-120	Microglass III (for disposable elements)
	ATZ 2-300	Cellulose
		Nom. rating
		Disposable element
		Wire mesh
		Abs. rating
		10C
		02Q
		05Q
		10Q
		20Q
		040W

Box 4	Seal type
	Seal material
	Code
	Nitrile
	Fluoroelastomer
	Neoprene
	B
	V
	N

Box 5	Indicator
	Code
	Vacuum gauge, setting -0.15 bar, M10x1
	Vacuum gauge, setting -0.3 bar, M10x1
	Vacuum switch 42V, -0.15 bar setting, NO, M10 x 1
	Vacuum switch 42V, -0.30 bar setting, NO, M10 x 1
	Vacuum switch 250 VAC, -0.15 bar setting, NO/NC, M10 x 1
	Vacuum switch 250 VAC, -0.30 bar setting, NO/NC, M10 x 1
	No indicator, indicator ports not machined
	No indicator, indicator port plugged
	Other settings for indicators / gauges on request
	U1
	U2
	V1
	V2
	V3
	V4
	N
	P
	on request

Box 6	Bypass valve
	Code
	Bypass valve
	Blocked bypass
	X

Box 7	Filter connection
	Ports
	Code
	G1½" + 2 x G1" (For ATZ 1-120 only)
	2½" SAE-3000 PSI + 2 x G1½" (For ATZ 2-300 only)
	G24
	R48

Box 8	Options
	Options for ATZ 1-120
	Code
	1 x G1½" + 1 x G1" plugged
	Not plugged
	1 x G1" right plugged
	2 x G1" left & right plugged
	Special
	on request
	Options for ATZ 2-300
	2½" SAE with blind counterflange
	No counterflange
	Special
	1
	Q
	on request

Highlights Key (Denotes part number availability)

123	Item is standard
123	Item is standard green option
123	Item is semi standard
123	Item is non standard

Degree of filtration						Media code
Average filtration beta ratio β (ISO 16889) / particle size µm [c]						
βx(c)=2	βx(c)=10	βx(c)=75	βx(c)=100	βx(c)=200	βx(c)=1000	
% efficiency, based on the above beta ratio (βx)						
50.0%	90.0%	98.7%	99.0%	99.5%	99.9%	02Q
N/A	N/A	N/A	N/A	N/A	4.5	05Q
N/A	N/A	4.5	5	6	7	10Q
N/A	6	8.5	9	10	12	20Q
6	11	17	18	20	22	

Spare element table						
ATZ 1-120	FXW1-R-10	FXW1-R-2	FXW1-R-5	FXW1-R-10	FXW1-R-20	SF1-R-40
Part number spare element	937958	937960Q	937962Q	937964Q	937966Q	937967
ATZ 2-300	FXW3-10	FXW3-2	FXW3-5	FXW3-10	FXW3-20	SF3-40
Part number spare element	937959	937961Q	937963Q	937965Q	944296Q	937968

ATZ Series Seal Kits	
Part Number	Description
2049010001	NITRILE SEAL KIT ATZ1
2049010060	FLUOROELASTOMER SEAL KIT ATZ1
2049010002	NITRILE SEAL KIT ATZ2



Visual indicator	
Setting	-0.3 bar
Thread connection	M10x1
Code	FMUJ2VBMM10L

Electrical switch	
Setting	-0.3 bar
Thread connection	M10x1
Switch type	NO
Elec.connection	AMP terminal 6.3x0.8
Protection	IP54 (terminal IP00)
Performance	125-250 VAC (Li 0,5A, Lr 2,0A max)
	12-28 Vdc (Li 1,0A, Lr3,0A max)
Code	FMUJ2VBMM10L

Note 1: Part numbers featured with bold highlighted codes will ensure a 'standard' product selection.

Note 2: Alternate displayed part number selection will require you to contact Parker Filtration for availability.

PT Tank Top Mounted filters

Max. 400 l/min - 10 bar



An economical alternative for quality tank top mounted filtration

In to out flow design avoids re-contamination of the hydraulic system

The PT tank top mounted filter features an aluminium filter head and screw-in style filter elements. This offers the opportunity to use the filter element as screw-in style for co-polymer reservoirs. With a Parker design that protects the quality of filtration, the PT offers a modularity and value for money.



Contact Information:

Parker Hannifin
Hydraulic Filter Division Europe

European Product Information Centre
Freephone: 00800 27 27 5374
(from AT, BE, CH, CZ, DE, EE, ES, FI, FR, IE, IT, PT, SE, SK, UK)
filtrationinfo@parker.com

www.parker.com/hfde

Product Features:

- Compact tank top mounted return line filter.
- Filter element can be used for direct screw-in mounting with co-polymer reservoirs.
- Parker quality filter element.
- In to Out flow avoids re-contamination of the system.
- Flow capability up to 400 l/min at 10 bar working pressure.

PT Tank Top Mounted filters

Max. 400 l/min - 10 bar

Features & Benefits

Features	Advantages	Benefits
Aluminium filter head	Low profile, lightweight and durable	Less weight, smaller envelope and cleaner appearance.
In-to-Out filtration	All captured contamination retains inside the element	No recontamination of the system during change of element
Disposable filter cartridge	Easy to change cartridge	New housing cover and seals provided with each element change
Microglass III media	Multi-layered design produces high capacity and efficiency	Reliable performance. Reduced downtime

Typical Applications

- Lorry mounted cranes
- Agricultural equipment
- Grass cutting equipment
- Container hook loaders

The Parker Filtration PT tank top mounted series

The PT Series filter is available in various sizes covering a flow rate up to 400 l/min. Using the Microglass III media in 2, 5, 10 and 20 microns it provides premium particle removal efficiency.

This unique design simply threads into a ported tank ring, which can be bolted to a metal reservoir.

The disposable filter cartridge is a single-piece construction, which incorporates the nylon cover and integral 1.7 bar bypass valve. The flow path is inside-out and requires no special tools for service.

This concept assures minimal installation costs with the least space requirements for return line applications.



Specification

Pressure ratings:

Max. 10 bar.

Connections

PT2: G¾" and G1"

PT4: G1" or G1¼"

Filter housing:

Aluminium

Filter element:

Parker design including cover for filter housing (one disposable unit)

Seal material:

Nitrile, viton

Operation temperature:

-20°C to + 100°C

Bypass:

1.7 bar

Degree of filtration:

Determined by multipass test in accordance to ISO16889

Flow fatigue:

Filter media is supported so that the optimal fatigue life is achieved (ISO3724)

Filter Media:

Microglass III

Indicator options:

Visual and electrical switch (NO/NC) type

Fluid compatibility:

Mineral and HEES type fluids

Principle of Filtration

The PT applies In-to-Out Filtration, this ensures that captured contamination is retained in the element during servicing the filter.

Bypass valve is integrated in the filter bottom element end cap. The filter element is completely disposable.

Safety First

Each spare filter element is including seals for the sealing between tank top mounted filter housing and filter element. Because all seals are pre-mounting, no risk that (incorrect) seals are not replaced.

PT Reservoir 'screw-in' solution to reduce costs and space

The PT applies In-to-Out Filtration, this ensures that captured contamination is retained. The PT element can be integrated directly into a co-polymer reservoir. Parker Filtration can provide cavity details to co-polymer reservoir manufacturers to support this innovative solution.

This cavity includes the integrated return line port and optional connection for the pressure switch.

Thanks to the complete screw-in style solution, typically over 30% of the first fit cost can be reduced, the reservoir surface remains flat and hence can support more compact solutions, in particular for mobile applications.

Compared to the traditional tank top mounted filter, improved sealing between the reservoir and the filter can be achieved, eliminating potential leakage areas by 50% typically.

Please consult Parker Filtration for engineered reservoir solutions



Installation Information

	'Build-in' length in tank (mm)
PT2 Length 1	95
PT2 Length 2	185
PT2 Length 3	280
PT4 Length 1	98
PT4 Length 2	189
PT4 Length 3	310

PT Tank Top Mounted filters

Max. 400 l/min - 10 bar

Specification (cont)

PT2 Assembly without funnel

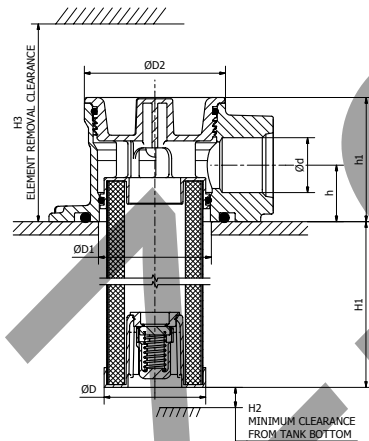
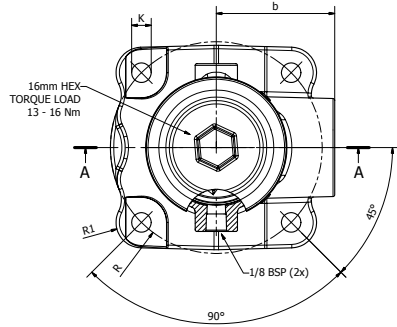

PT2 Screw-in Filter

Type	Connection Options	H1	H2	H3	h	h1	ØD	ØD1+/-0,5	ØD2	b	R	R1	K
PT2-1	G3/4, G1	89	6,5	190	25,4	56	Ø46	Ø51	Ø64	53	48	12	4x8,8
PT2-2	G3/4, G1	181	6,5	293	25,4	56	Ø46	Ø51	Ø64	53	48	12	4x8,8

PT2 Assembly with funnel

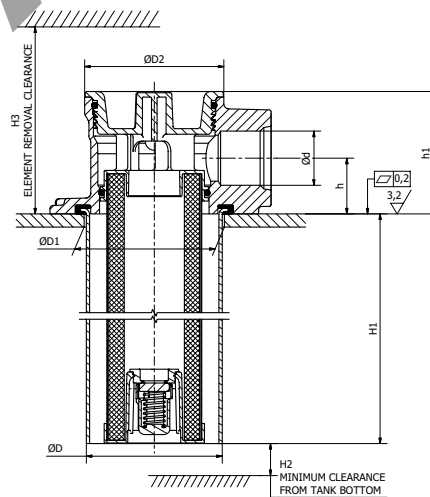
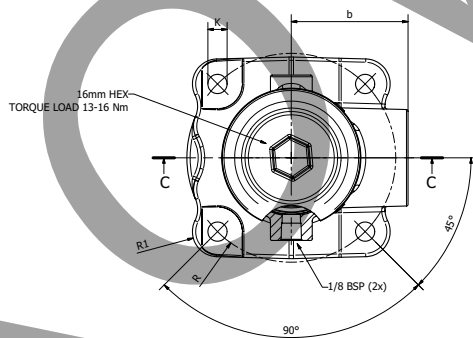

PT2 Screw-in Filter

Type	Connection Options	H1	H2	H3	h	h1	ØD	ØD1 +/-0,5	ØD2	b	R	R1	K
PT2-1	G3/4, G1	89	6,5	190	25,4	56	Ø62	Ø64	Ø64	53	48	12	4x8,8
PT2-2	G3/4, G1	181	6,5	293	25,4	56	Ø62	Ø64	Ø64	53	48	12	4x8,8

Specification (cont)

PT4 Assembly without funnel

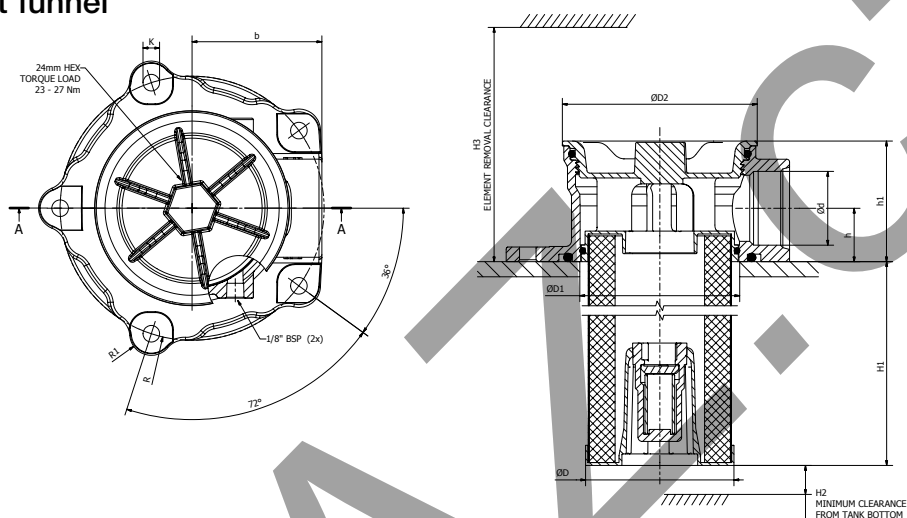

PT4 Screw-in Filter

Type	Connection Options	H1	H2	H3	h	h1	ØD	ØD1+/-0,5	ØD2	b	R	R1	K
PT4-1	G1, G1-1/4	94	10	222	28.2	64	Ø78.5	Ø85	Ø103	69	70	12	5xØ8.8
PT4-2	G1, G1-1/4	185	10	313	28.2	64	Ø78.5	Ø85	Ø103	69	70	12	5xØ8.8
PT4-3	G1, G1-1/4	306	10	434	28.2	64	Ø78.5	Ø85	Ø103	69	70	12	5xØ8.8

PT4 Assembly with funnel

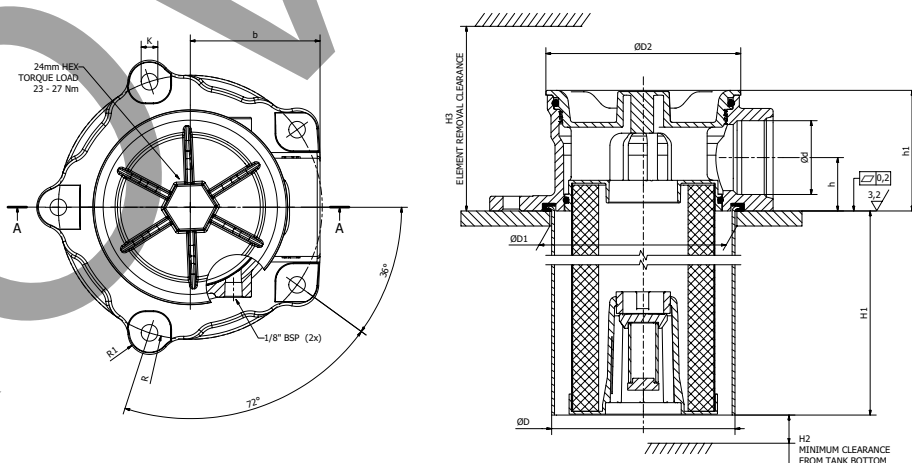

PT4 Screw-in Filter

Type	Connection Options	H1	H2	H3	h	h1	ØD	ØD1 +/-0,5	ØD2	b	R	R1	K
PT4-1	G1, G1-1/4	94	10	222	28.2	64	Ø97	Ø99	Ø103	69	70	12	5xØ8.8
PT4-2	G1, G1-1/4	185	10	313	28.2	64	Ø97	Ø99	Ø103	69	70	12	5xØ8.8
PT4-3	G1, G1-1/4	306	10	434	28.2	64	Ø97	Ø99	Ø103	69	70	12	5xØ8.8

PT Tank Top Mounted filters

Max. 400 l/min - 10 bar

Pressure Drop Curves

Flow Performance Charts - PT2 Series

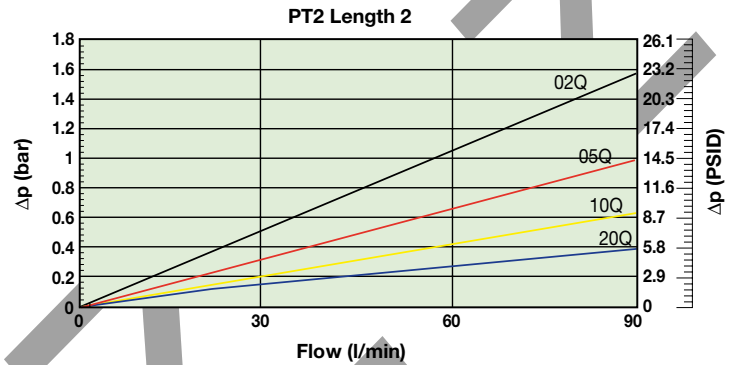
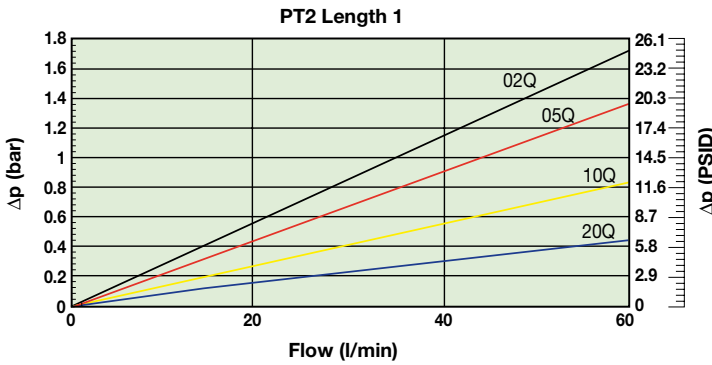

All delta-p values are based on 30 cSt fluid and 0,87 kg/l density

Flow Performance Charts - PT4 Series

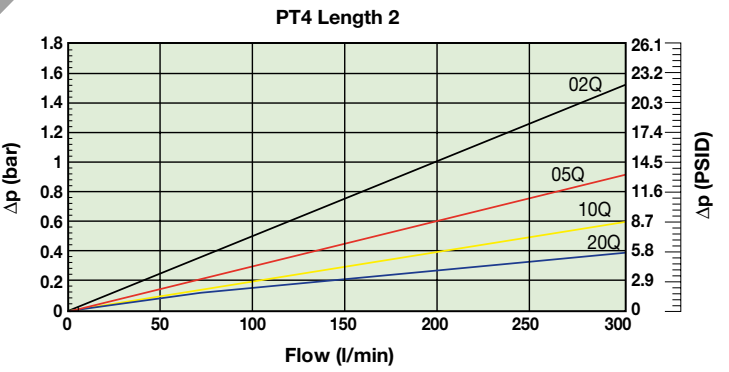
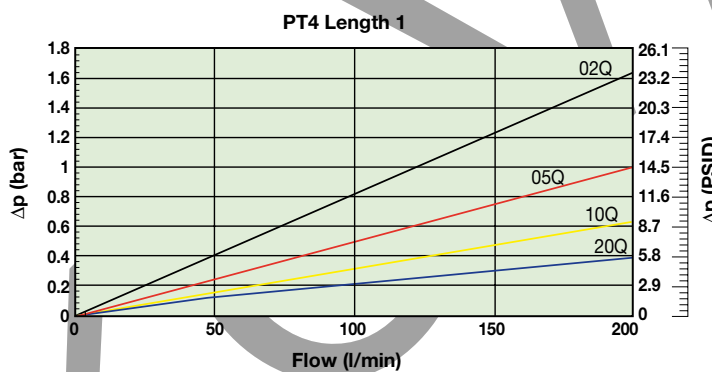

Flow Performance Charts - PT4 Series

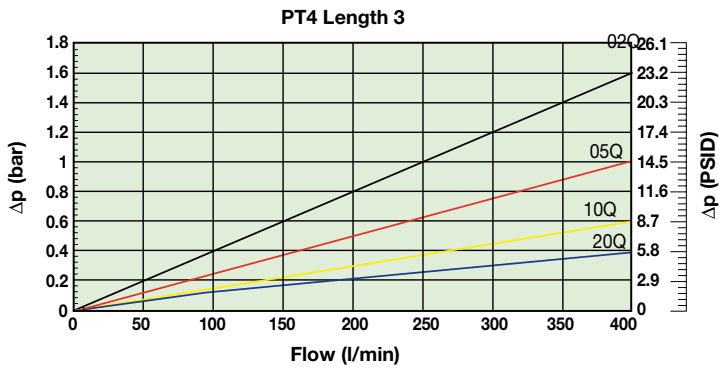

Indicator Information

Indicator PS NO/NC pressure switch

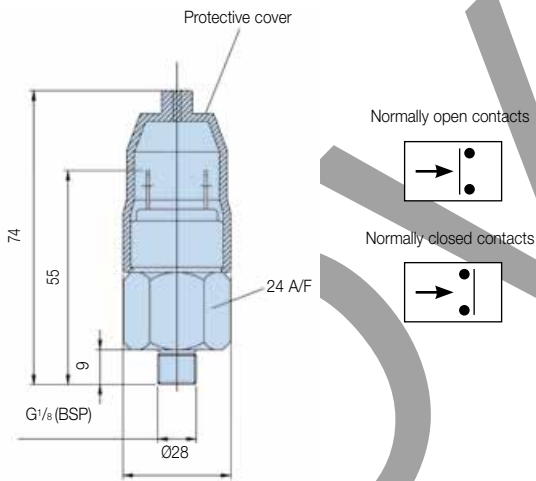

Pressure Switches	
Elec. rating	42V / 2A
Thread connection	G ¹ / ₈
Elec. connection	AMP terminal 6.3 x 0.8
Protection	IP65 (terminal IP00)
Switch type	NO or NC
Indicator setting	1.2 bar
Code	FMUS2EBMG02L (NO switch) FMUS3EBMG02L (NC switch)
Visual Indicator	Code
1.2 bar	FMUG2EBPG02L

Ordering Information

Product configurator

Configurator example PT filter

Box 1	Box 2	Box 3	Box 4	Box 5	Box 6	Box 7	Box 8
PT2	1	10Q	B	P	G	G12	I

Box 1

Housing	Code
PT2	PT2
PT4	PT4

Highlights Key (Denotes part number availability)

123	Item is standard
123	Item is semi standard
123	Item is non standard

Box 2

Element Length	Code
Length 1	1
Length 2	2
Length 3 (PT4 only)	3

Box 3

Filter media (Microglass III)	Code
2 micron	02Q
5 micron	05Q
10 micron	10Q
20 micron	20Q

Box 4

Seal Material	Code
Nitrile	B
Fluoroe/astomer	V

Box 5

Indicator	Code
Plugged port	P
Pressure Switch 42V, 1.2 bar setting, NO	S2
Pressure Switch 42V, 1.2 bar setting, NC	S3
Pressure gauge, setting 1.2 bar, G $\frac{1}{8}$	G2

Box 6

Bypass Valve	Code
1.7 bar	G

Box 7

Ports	Code
G $\frac{1}{4}$ (PT2 only)	G12
G1	G16
G1 $\frac{1}{4}$ (PT4 only)	G20

Box 8

Options	Code
No diffuser required	1
Airtight diffuser	4

Spare Filter Elements

Media	PT2-1	PT2-2	PT4-1	PT4-2	PT4-3
02Q	936753Q	936757Q	936745Q	936749Q	936879Q
05Q	936752Q	936756Q	936744Q	936748Q	936878Q
10Q	936751Q	936755Q	936743Q	936747Q	936877Q
20Q	936750Q	936754Q	936742Q	936746Q	936876Q

Filter Media Efficiency

Degree of filtration						Media code
Average filtration beta ratio β (ISO 16889) / particle size μm [c]						
$\beta_x(c)=2$	$\beta_x(c)=10$	$\beta_x(c)=75$	$\beta_x(c)=100$	$\beta_x(c)=200$	$\beta_x(c)=1000$	
% efficiency, based on the above beta ratio (β_x)						
50.0%	90.0%	98.7%	99.0%	99.5%	99.9%	
N/A	N/A	N/A	N/A	N/A	4.5	02Q/02QL
N/A	N/A	4.5	5	6	7	05Q/05QL
N/A	6	8.5	9	10	12	10Q/10QL
6	11	17	18	20	22	20Q/20QL

Note 1: Part numbers featured with bold highlighted codes will ensure a 'standard' product selection.

Note 2: Alternate displayed part number selection will require you to contact Parker Filtration for availability.

STF Series

Return Line Filters

Max. 500 l/min - 10 bar



When safety is an essential requirement

Where the use of aluminium is restricted in applications such as marine and industrial, the STF return line filter series provides an ideal solution to hydraulic system designers and specifiers.



Contact Information:

Parker Hannifin
Hydraulic Filter Division Europe

European Product
Information Centre
Freephone: 00800 27 27 5374
(from AT, BE, CH, CZ, DE, EE, ES,
FI, FR, IE, IT, PT, SE, SK, UK)
filtrationinfo@parker.com

www.parker.com/hfde

Product Features:

- 'In-to-out' filtration design means contaminated oil cannot leak back into the system.
- Magnetic pre-filtration.
- Cast iron filter head assembly
- Multiple port configuration.
- Flows up to 500 L/min.
- 10 bar maximum working pressure.
- Optional airtight diffusers.
- *LEIF*[®] low environmental impact filter elements as standard.

STF Series

Return Line Filters

Features & Benefits

Features	Advantages	Benefits
10 bar rated filter	Can be utilised for severe return line applications	Reduced downtime due to premature filter failures
Cast iron head	Robust design	Convenient and effective solution for applications where aluminium is not allowed
LEIF® elements	Element safeguards the use of genuine parts	Guaranteed quality of filtration Contributes to ISO 14001 certification
Magnetic pre-filtration	Removes ferrous particles, even during bypass conditions	Improved fluid cleanliness levels Extended element life time
In-to-Out filtration	All captured contamination retains inside the element	No recontamination of system during change of elements
High level of customisation	Dedicated system-matched solutions can be easily made available	Improved integration of filter in system combined with lower initial system costs
Quick response bypass with low hysteresis	Reduction of bypass period due to low hysteresis Only a small part of the total flow is bypassing the element	Improved protection of system
Standard or customised funnel	Ensures that oil enters the tank under the oil level	Significant reduction of oil foaming

Typical Applications

- Marine power pack
- Steel mills
- Mining equipment
- Drilling equipment

The Parker Filtration STF Series Return Line Filters

STF Tank top mounted return filters feature pre-filtration by means of a magnet column and a bypass with low hysteresis. Thanks to the “In-to-Out” filtration principle, contaminated oil cannot leak back into the system. The STF filter has a casted iron filter head assembly, making it ideal for marine and industrial applications where the use of aluminium is restricted. The filter head with multiple ports, capable of handling flow up to 500 l/min at 10 bar working pressure, represents an easy and effective way of integrating return line filtration with power packs. Optional airtight diffusers are standard to avoid air ingress in the return line.

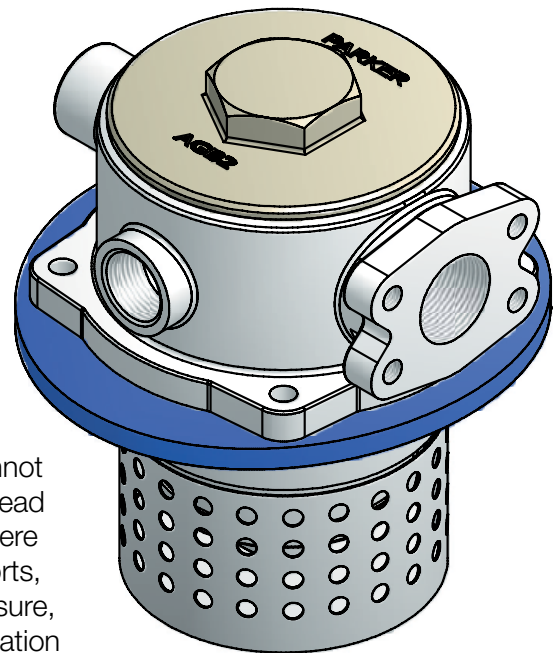

Specification

Operation pressure:
Max. 10 bar

Assembly
Tank top mounted

Connections
SAE flange
Threaded BSP ports

Filter housing and cover
Cast Iron (GGG40)

Seal material:
Nitrile, Fluorelastomer

Operating temperature:
Seal material Nitrile: -40°C to +100°C
Seal material Fluoroelastomer: -20°C to +120°C

Bypass setting
Opening pressure 0,8 / 1,5 / 2,0 bar

Degree of filtration
Determined by multipass test in accordance to ISO16889

Flow fatigue characteristics
Filter media is supported so that the optimum fatigue life is achieved

Filtration media

Microglass III and Ecoglass III for *LEIF*[®] elements
Also available 10 µm cellulose and 40 µm stainless steel mesh

Element burst pressure
10 bar (ISO 2941)

Pressure indicator options
Setting 0,7 and 1,2 bar
Visual pressure gauge
Electrical pressure switch

Options

Diffuser type P (straight pipe, no perforated plate area)
Diffuser type T (with closed diffuser end cap and with perforated plate area, recommended when oil entry in the reservoir is close to the bottom or to ensure oil enters the reservoir under the oil level)

Magnetic pack
Standard, only not included for STF 400 and 500

Filter element

LEIF[®] element with reusable metal element sleeve
Optional conventional style element with steel end caps
The *LEIF*[®] element is patented and safeguards the use of genuine parts.

Note:
LEIF[®] element can be used with mineral and HEES type oils
For other fluids consult Parker Filtration
LEIF[®] element contributes to ISO14001 quality standards

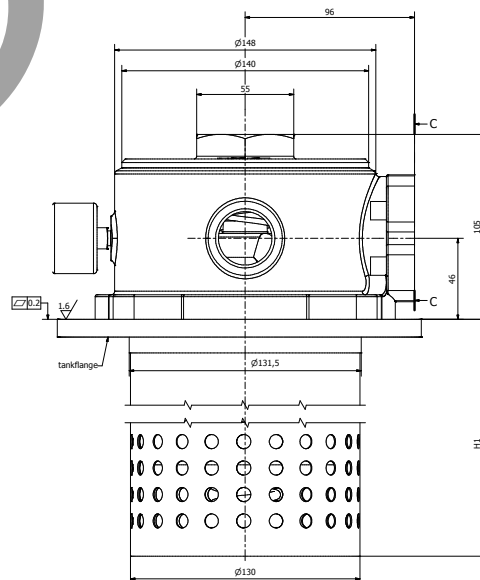
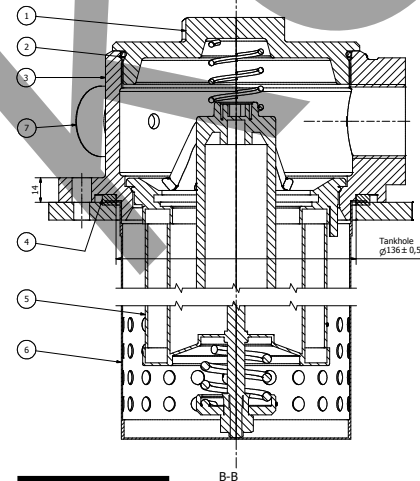
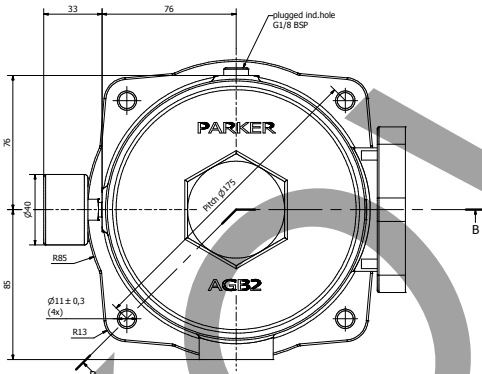

STF Without Diffuser		
STF Length	Type	H1
6	STF170	223
7	STF230	303
8	STF300	508
9	STF400	523
10	STF500	563

STF With Diffuser		
STF Length	Type	H1
6	STF170	305
7	STF230	305
8	STF300	510
9	STF400	525
10	STF500	575

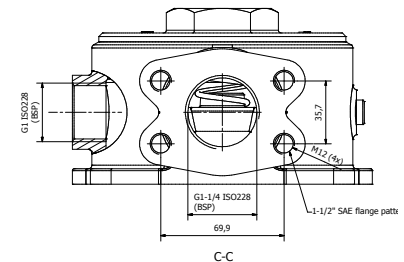

STF Series

Return Line Filters

Pressure Drop Curves

The recommended level of the initial pressure drop for low pressure filters is max 0.5 bar.

If the medium used has a viscosity different from 32cSt, pressure drop over the filter can be estimated as follows:

$$\Delta p = (\Delta p_{32} \times \text{viscosity of medium used}) / 32\text{cSt}$$

STF170 (Element length code 6)

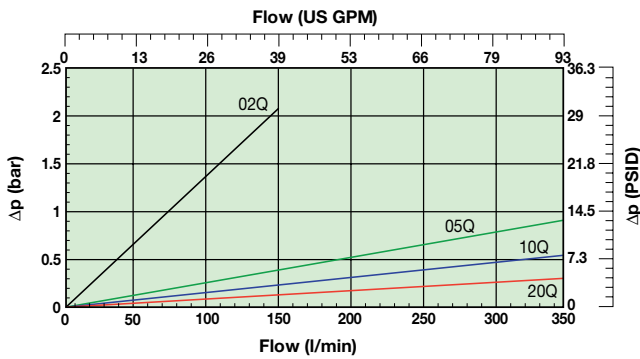

STF230 (Element length code 7)

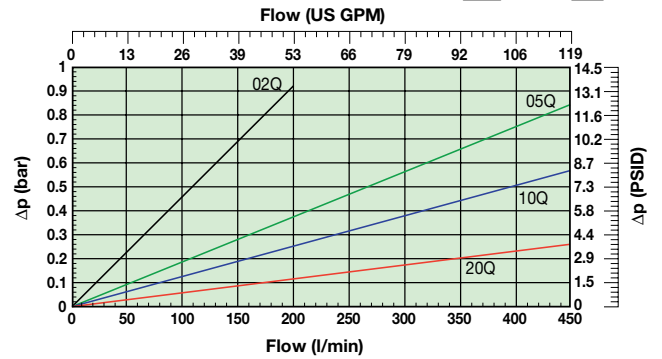

STF300 (Element length code 8)

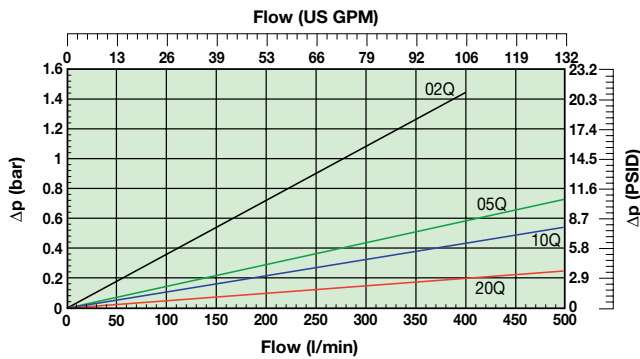

STF400 (Element length code 9)

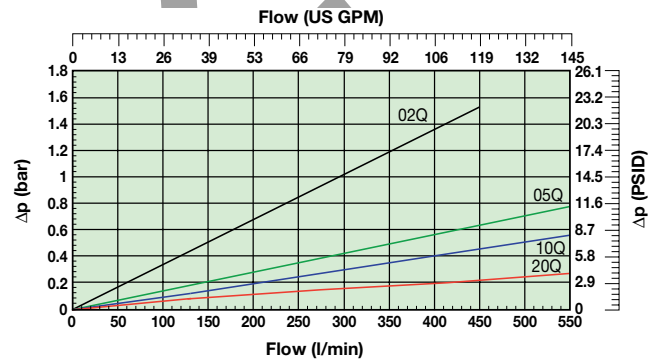

STF500 (Element length code 10)

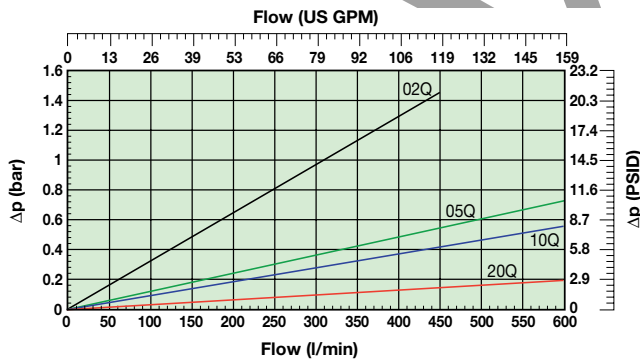

**STF170 (Element length code 6)
Cellulose & stainless steel media**

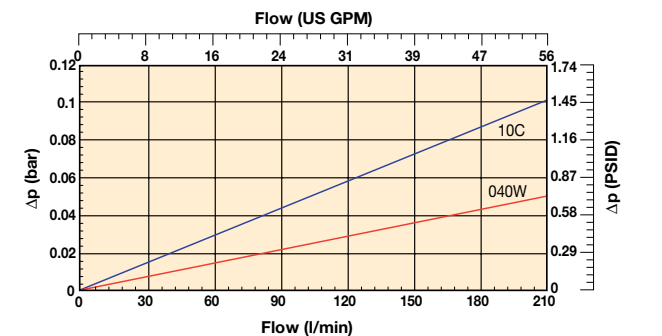

**STF230 (Element length code 7)
Cellulose & stainless steel media**

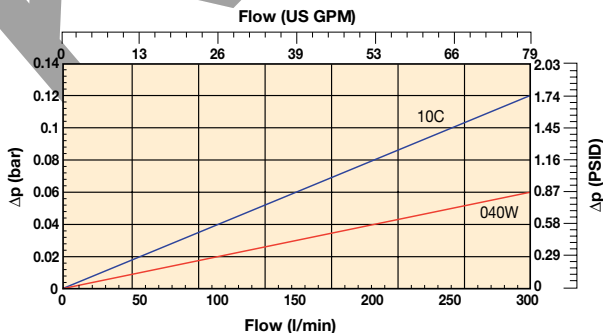

**STF300 (Element length code 8)
Cellulose & stainless steel media**

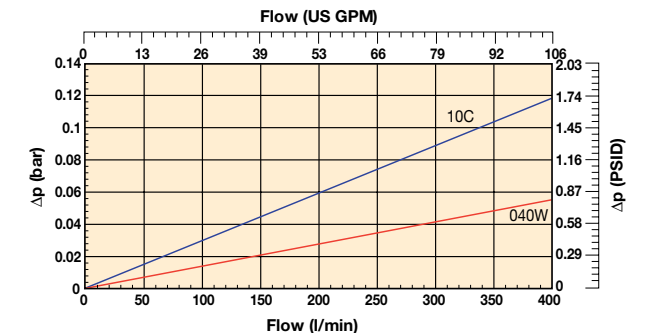

STF Series

Return Line Filters

Indicator PS NO/NC pressure switch

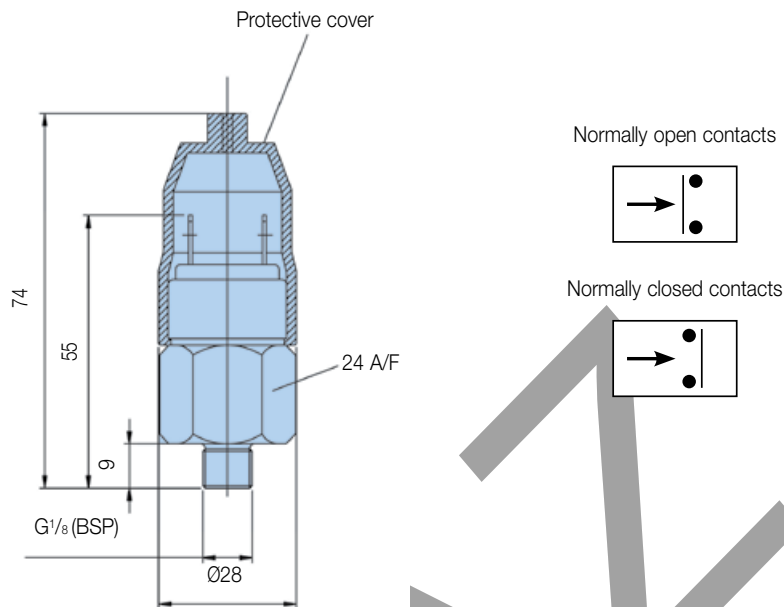

Specifications	
Electrical rating	42V / 2A
Thread connection	G1/8"
Electrical connection	AMP terminal 6.3x0.8
Protection	IP65 (terminal IP00)
Switch type	NO or NC
Indicator setting	1.2 bar (0.7 bar on request)
Code	FMUS2EBMG02L (NO type switch) FMUS3EBMG02L (NC type switch)

Visual indicator	Code
1.2 bar	FMUG2EBPG02L

LEIF Spare Element table				
	2 micron	5 micron	10 micron	20 micron
STF170 Part number spare element	937827Q	937848Q	937853Q	937874Q
STF230 Part number spare element	937828Q	937847Q	937854Q	937873Q
STF300 Part number spare element	937829Q	937846Q	937855Q	937872Q
STF400 Part number spare element	937830Q	937845Q	937856Q	937871Q
STF500 Part number spare element	937831Q	937844Q	937857Q	937870Q

Conventional Spare Element table Microglass III Media						
	10 micron cellulose	2µ Microglass III	5µ Microglass III	10µ Microglass III	20µ Microglass III	40 micron stainless steel mesh
STF170 Part number spare element	937725	937747Q	937758Q	937783Q	937794Q	937816
STF230 Part number spare element	937726	937746Q	937759Q	937782Q	937795Q	937815
STF300 Part number spare element	937727	937745Q	937760Q	937781Q	937796Q	937814

Ordering Information

Standard products table										
Part Number	Flow (l/min)	Model Number	Element Length	Media Rating (u)	Seals	Indicator	Bypass Setting	Ports	Included Options	Replacement Elements
STF810QLBP2ELC24G	300	STF300	8	10	Nitrile	Plugged	1.5 Bar	11/2"SAE-flange	Airtight funnel typeT	937855Q
STF820QLBP2ELC24G	300	STF300	8	20	Nitrile	Plugged	1.5 Bar	11/2"SAE-flange	Airtight funnel typeT	937872Q
STF1010QLBP2ELC24G	500	STF500	10	10	Nitrile	Plugged	1.5 Bar	11/2"SAE-flange	Airtight funnel typeT	937857Q
STF1020QLBP2ELC24G	500	STF500	10	20	Nitrile	Plugged	1.5 Bar	11/2"SAE-flange	Airtight funnel typeT	937870Q

Product configurator

Configurator example of a STF Series filter

Box 1	Box 2	Box 3	Box 4	Box 5	Box 6	Box 7	Box 8
STF	8	05QL	B	S2	E	LC24	G

Box 1	Box 2	Box 3																																
Code	Filter type	Degree of filtration																																
STF	<table border="1"> <thead> <tr> <th>Housing</th> <th>Code</th> </tr> </thead> <tbody> <tr> <td>STF 2-170</td> <td>6</td> </tr> <tr> <td>STF 2-230</td> <td>7</td> </tr> <tr> <td>STF 2-300</td> <td>8</td> </tr> <tr> <td>STF 2-400</td> <td>9</td> </tr> <tr> <td>STF 2-500</td> <td>10</td> </tr> </tbody> </table>	Housing	Code	STF 2-170	6	STF 2-230	7	STF 2-300	8	STF 2-400	9	STF 2-500	10	<table border="1"> <thead> <tr> <th>Element media</th> <th>Nominal Cellulose</th> <th>Filtration fineness absolute</th> <th>Stainless steel mesh</th> </tr> </thead> <tbody> <tr> <td rowspan="2">Disposable element</td> <td rowspan="2">10µm</td> <td colspan="2">Q3 glassfibre Bx(c) >200</td> </tr> <tr> <td>Q02 (2micron)</td> <td>Q05 (5micron)</td> <td>Q010 (10micron)</td> <td>Q020 (20micron)</td> <td>40µm</td> </tr> <tr> <td>LEIF[®] element</td> <td>10C</td> <td>02Q</td> <td>05Q</td> <td>10Q</td> <td>20Q</td> <td>040W</td> </tr> </tbody> </table>	Element media	Nominal Cellulose	Filtration fineness absolute	Stainless steel mesh	Disposable element	10µm	Q3 glassfibre Bx(c) >200		Q02 (2micron)	Q05 (5micron)	Q010 (10micron)	Q020 (20micron)	40µm	LEIF [®] element	10C	02Q	05Q	10Q	20Q	040W
Housing	Code																																	
STF 2-170	6																																	
STF 2-230	7																																	
STF 2-300	8																																	
STF 2-400	9																																	
STF 2-500	10																																	
Element media	Nominal Cellulose	Filtration fineness absolute	Stainless steel mesh																															
Disposable element	10µm	Q3 glassfibre Bx(c) >200																																
		Q02 (2micron)	Q05 (5micron)	Q010 (10micron)	Q020 (20micron)	40µm																												
LEIF [®] element	10C	02Q	05Q	10Q	20Q	040W																												

Seal type	
Seal material	Code
Nitrile	B
Fluorelastomer	V

Indicator	
	Code
Pressure gauge , setting 1.2 bar, G1/8	G2
Pressure switch 42V, 1.2 bar setting, NO with G1/8 BSP	S2
Pressure switch 42V, 1.2 bar setting, NC with G1/8 BSP	S3
Pressure switch 250V, NO/NC with G1/8	S4
No indicator, indicator ports L + R plugged	P2
Other settings for indicators / gauges on request	on request

Bypass valve	
Bypass valve	Code
0.8 bar	B
1.5 bar	E
2.0 bar for STF series	H
Blocked bypass	X
Other bypass settings	on request

Filter connection	
Ports	Code
1½" SAE-3000 M (G1¼" inside) + G1 (2nd port)	LC24
G1½" + G1" (2nd port)	GL24

Options	
Options	Code
No diffuser required	1
Diffuser type T with perforated plate area	3
Diffuser type P without perforated plate area	4
Airtight diffuser type T with perforated plate area	G
Airtight diffuser type P without perforated plate area	H
Other combinations	on request
ATEX certified* (Category 2, non-electrical equipment)	EX

Note 1: STF size 2-400 and 2-500 are standard supplied without magnets
 Note 2*:For ATEX classified filters add EX after the code.
 ATEX certified filters with electrical indicator are available on request.
 Visual indicators are classified as Category 2, non electrical equipment.
 Filter assemblies with EX code will be supplied with a dedicated name plate.
 Pls consult Parker Filtration for any questions related to the classification of our products.

Degree of filtration						Media code
Average filtration beta ratio β (ISO 16889) / particle size µm [c]						
Bx(c)=2	Bx(c)=10	Bx(c)=75	Bx(c)=100	Bx(c)=200	Bx(c)=1000	
% efficiency, based on the above beta ratio (βx)						
50.0%	90.0%	98.7%	99.0%	99.5%	99.9%	02Q/02QL
N/A	N/A	N/A	N/A	N/A	4.5	05Q/05QL
N/A	N/A	4.5	5	6	7	10Q/10QL
N/A	6	8.5	9	10	12	20Q/20QL
6	11	17	18	20	22	

Highlights Key (Denotes part number availability)

123	Item is standard
123	Item is standard green option
123	Item is semi standard
123	Item is non standard

STF Series Seal Kit	
Part number	Description
2049010076	NITRILE SEAL KIT STF

Oil Conditioning Unit (OCU)

Off-line filtration for the removal of water or particulate from hydraulic and lube system fluids.



A cost-effective solution that helps ensure system reliability.

The Parker Oil Conditioning Units (OCU) are a family of off-line filtration packages designed to effectively remove water or particulate contamination from hydraulic and lube system fluids. The high performance, high capacity design enables the efficient removal of the very fine contaminants that cause premature wear in expensive hydraulic components. In addition, the precursors to varnish are also reduced or eliminated completely.

The compact, user-friendly OCUs are a cost effective method of reducing system contamination while helping to ensure the reliability of your hydraulic or lube system.



Contact Information:

Parker Hannifin
Hydraulic Filter Division Europe

European Product
Information Centre
Freephone: 00800 27 27 5374
(from AT, BE, CH, CZ, DE, EE, ES,
FI, FR, IE, IT, PT, SE, SK, UK)
filtrationinfo@parker.com

www.parker.com/hfde

Product Applications:

- **Aviation**
 - ground support equipment
 - simulators
- **Power Generation**
 - steam and gas turbine hydraulic and lubrication
- **Automotive**
 - presses
 - stamping equipment
- **Steel Mills**
 - rolling mills
 - continuous casters
 - sheet mills
- **Injection Moulding**
 - hydraulic circuits
- **Railway**
 - car assembly
 - wheel presses
- **Pulp & Paper**
 - machine lubrication
- **Construction**
 - timber harvesting
 - aerial lifts
 - excavators
- **Wind Power**
 - turbine generators
 - gearboxes
- **Oil & Gas**
 - hydraulic equipment

Technology

Oil Conditioning Unit

The filter design allows the oil to flow under pressure through 114mm of engineered media with three distinct stages of filtration and water absorption.

The largest particles are retained in the top of the element (1), making for an excellent diagnostic tool. Smaller particles are trapped in the mid stage (2), and the smallest particles are trapped in the lower and most compressed part of the element (3).

The cellulose media allows water absorption of up to 200 millilitres within the filter, reducing the water concentration in oil to less than 100 parts per million typically.

Equally noteworthy is the efficiency of the media in removing resins, metals and oxidation products, all of which are extremely damaging to close-tolerance components.

Manufactured from a specifically engineered cellulose material wound onto a central core, the OCU combines filtration principles to achieve effective filtration – low flow, low pressure and depth loading axial filtration – flow direction from the top to the bottom.

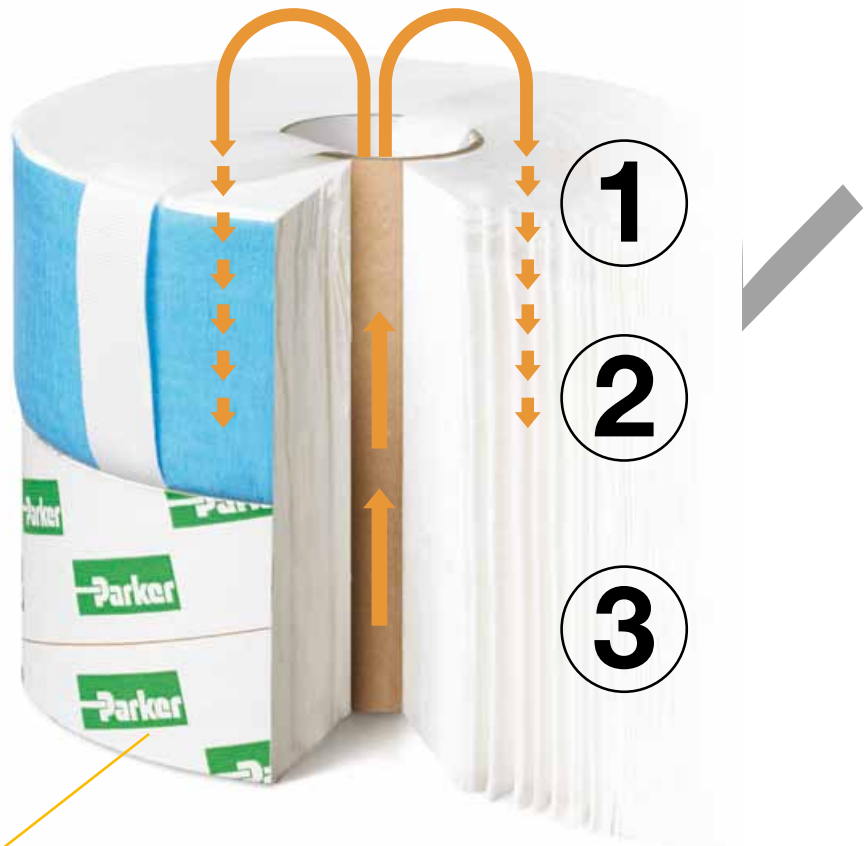

A card sleeve compresses the lower part of the element to increase the density and a non-woven cloth protects the base and stops particle migration.

Features and Benefits

- Solid Partical Filtration
- Water Absorption
- Sludge, Resin, and Oxidation Absorption

The Parker OCU Benefits

- Removing up to 99% of all Solid Contaminates typically
- Reducing the Water Concentration to Less than 100 ppm typically
- Eliminating Resins and Oxidation Products
- Longer Life for Hydraulic Components
- Significant Reduction of Oil Consumption and Oil Disposal Cost
- Low Cost Full Flow Filter Cartridges
- Reduce Equipment Downtime
- Reduce Operating Cost
- Increase Profit

Features and Benefits Continued



Tool-less access and easy service via the T-handle.

The combination of chemically treated cellulose and synthetic layers of media presents a massive surface area to remove solid contamination and emulsified water. The result is both exceptional dirt holding capacity and removal of water concentration to less than 100 ppm.

The engineered base design at the bottom of the housing supports the element under high pressure and provides a channelled migration path for clean fluid to flow back into the primary stream.

The Oil Conditioning Unit is designed as a top load filter, but can be mounted at any angle using the heavy-duty mounting bracket.



The intricately channelled base provides a large footprint to fully support the element under pressure, ensuring uniform loading of the element. Ultra-clean oil flows through the channels into the clean oil stream.

Element Performance

Model OC1				
Media Grade	Part Number	Capacity @ 1.7 bar (25 PSID)	Capacity @ 3.5 bar (50 PSID)	Efficiency
2 Micron	942650	16.2 grams	23.3 grams	B2>400
10 Micron	942652	28 grams	44.3 grams	B10>400

Model OC2				
Media Grade	Part Number	Capacity @ 1.7 bar (25 PSID)	Capacity @ 3.5 bar (50 PSID)	Efficiency
2 Micron	942654	22 grams	45.8 grams	B2>400
10 Micron	942656	36.5 grams	61.6 grams	B10>400

Water absorption for the OC2 element (part number 942682) is typically 900 cc.

Results typical from Multipass tests run per modified test standard ISO 16889 to 3.5 bar (50 PSID) terminal - 100 mg/L BUGL ISO Medium Test Dust was used as per the standard - User results will vary based on system particle distribution.

Dirt Holding Capacity results will typically improve with soft or sub-micron size particles due to reduced surface 'caking'.

OC1 without Pump/Motor

Specifications

Specifications	OC1
Maximum Pressure	12.4 bar (180 PSI)
Maximum system pressure	245 bar (3552 PSI)
Port Size (inlet/outlet)	SAE 6/SAE 6
Dimensions	W162 x D166 x H317 mm (W6.38 x D6.54 x H12.48 in.)
Weight	4.5 kg (10 lbs)
Flow Rate	1.5 L/min. (0.4 GPM)

The Parker OCU filter is supplied including:

- Flow / pressure control valve
- Bypass valve

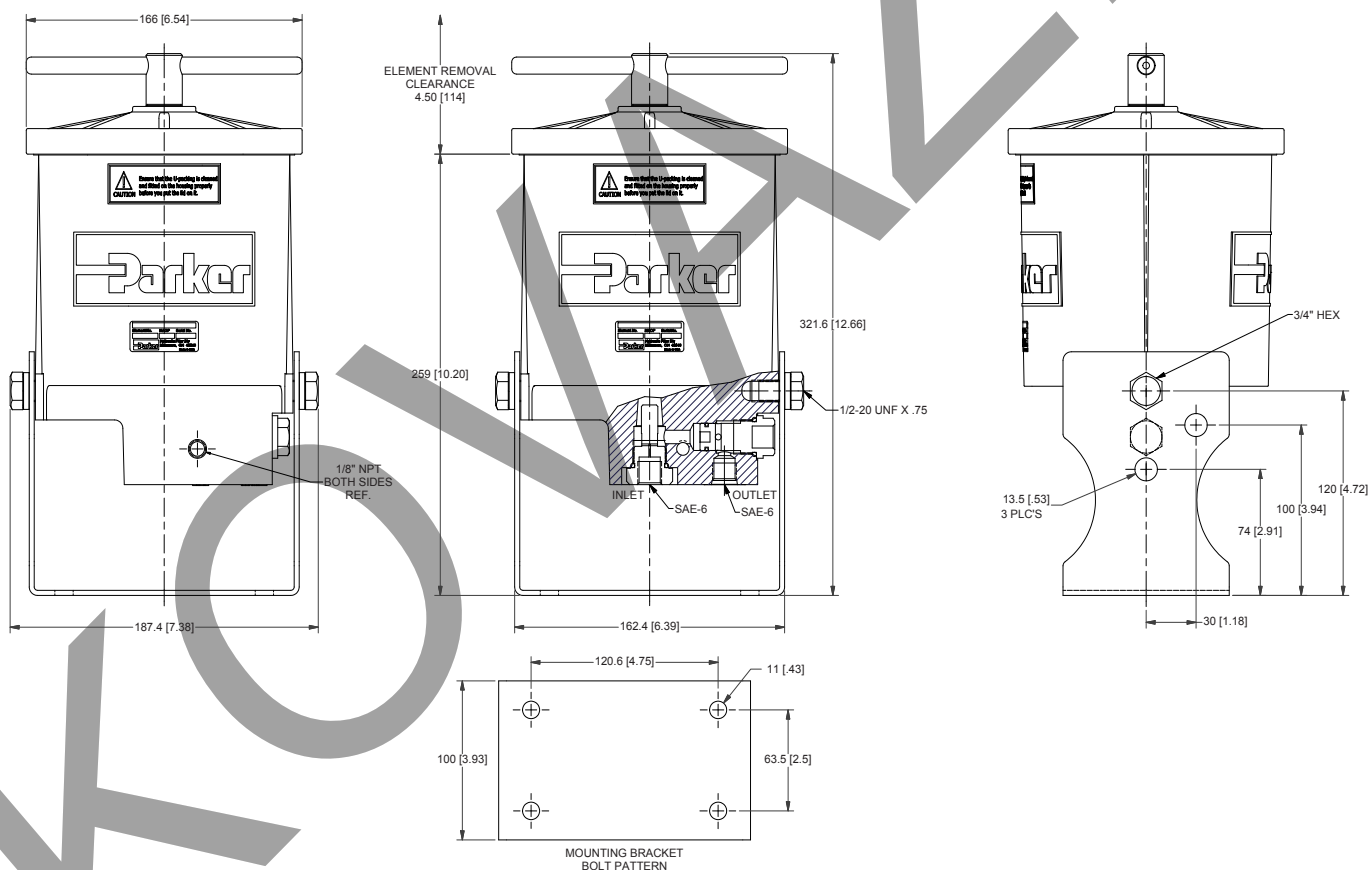

* Dimensions in mm (inch)

OC2 without Pump/Motor

Specifications

Specifications	OC2
Maximum Pressure	12.4 bar (180 PSI)
Maximum system pressure	245 bar (3552 PSI)
Port Size (inlet/outlet)	SAE 6/SAE 8
Dimensions	W204 x D206 x H321 mm (W8.03 x D8.11 x H12.64 in)
Weight	6.8 kg. (15 lbs)
Flow Rate	2 L/min. (0.5 GPM)

The Parker OCU filter is supplied including:

- Flow / pressure control valve
- Bypass valve

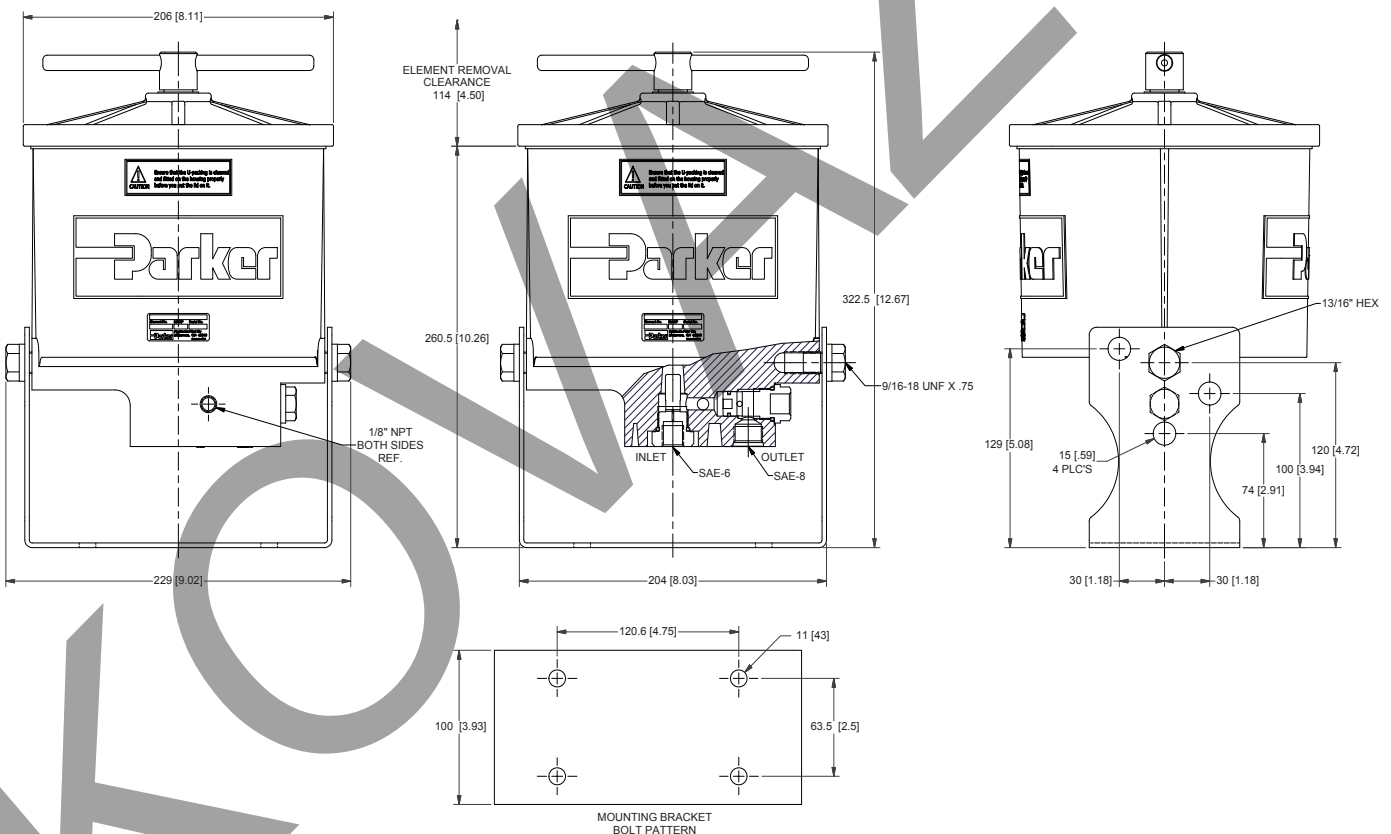

* Dimensions in mm (inch)

OC2 with Pump/Motor

Specifications

Specifications	OC2
Maximum Pressure	12.4 bar (180 PSI)
Port Size (inlet/outlet)	SAE 6/SAE 6
Dimensions	W204 x D206 x H321 mm. (W8.03 x D8.11 x H12.64 in)
Weight	10 kg. (22.1 lbs)
Flow Rate	2 L/min. (0.5 GPM)
Voltage	120VAC or 220VAC

The Parker OCU filter is supplied including:

- Flow / pressure control valve
- Bypass valve

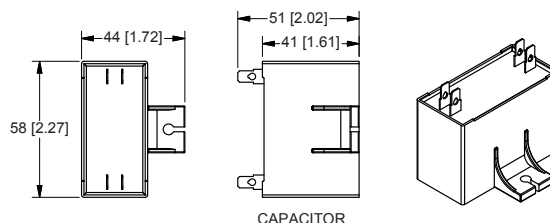
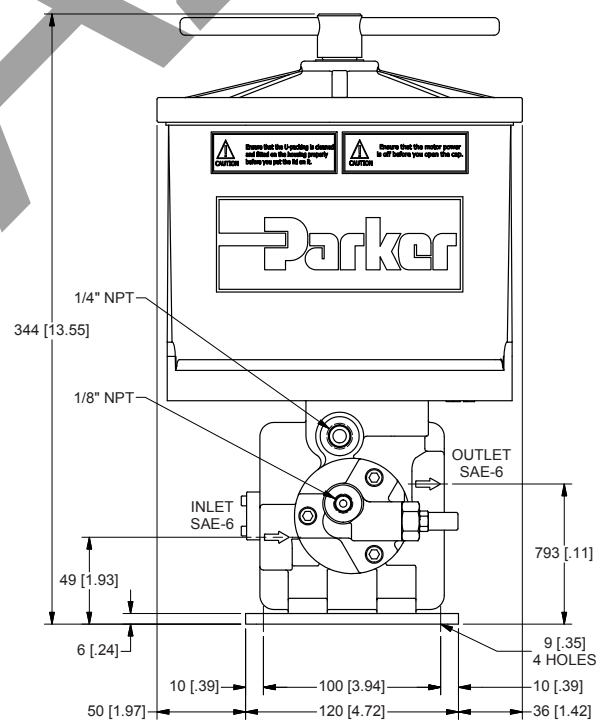
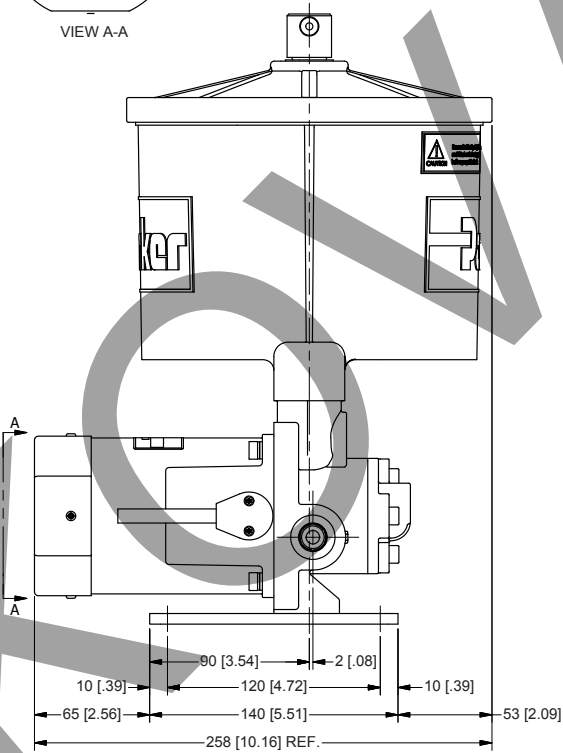
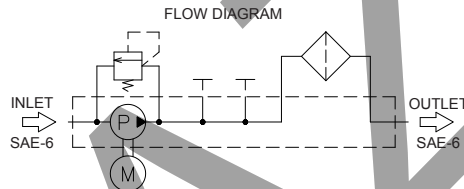
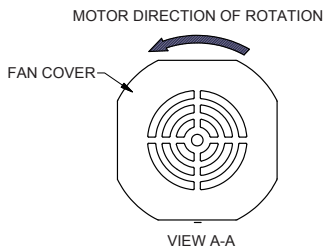

* Dimensions in mm (inch)



Oil Conditioning Unit

Parts List

Replacement Parts List	
942673	Seal Service Kit (for OC1)
942683	Seal Service Kit (for OC2)



Replacement Elements	
OC1	
942650	2 micron (green)
942652	10 micron (orange)
OC2	
942654	2 micron filter (green)
942656	10 micron filter (orange)
942682	Water Removal

Oil Conditioning Unit

Ordering Information

Select the desired symbol (in the correct position) to construct a model code.
Example:

BOX 1	BOX 2	BOX 3	BOX 4	BOX 5	BOX 6	BOX 7	BOX 8
OC2	120	10	V	P	L	S06	1

BOX 1: Filter Series ¹	
Symbol	Description
OC1	1.5 L/min. (0.4 GPM)
OC2	2.0 L/min. (0.5 GPM) ¹

BOX 2: Filter Model ^{1,2}	
Symbol	Description
120	120VAC/1Ph/60Hz Pump/Motor ²
220	220VAC/1Ph/50/60Hz Pump/Motor ²
X	No Pump/Motor ¹

BOX 3: Media Code ³	
Symbol	Description
2	2 micron
10	10 micron
WR	Water Removal ³

BOX 4: Seals	
Symbol	Description
V	Fluorocarbon (FKM)

BOX 5: Indicator	
Symbol	Description
P	Indicator Port Plugged
G	Pressure Gauge
S	Pressure Switch

BOX 6: Bypass	
Symbol	Pressure Setting
L	4.5 bar (65 psid) relief

BOX 7: Ports ⁴	
Symbol	Description
S06	SAE-6 Inlet/Outlet Ports
S08	SAE-6 Inlet Port/SAE-8 Outlet Port ⁴

BOX 8: Options	
Symbol	Description
1	None

Notes:

- When selection from Box 1 is "OC2", and selection from Box 2 is "X", "S08" **must** be selected for Box 7.
- "120" and "220" are available **only** when "OC2" is selected in Box 1.
- "WR" available for OC2 **only**.
- "S08" is **only** used when "OC2" is selected in Box 1 and "X" is selected in Box 2.

SF1040 Series

Low Pressure Filters

Max. 1400 l/min. 10 bar



Multi-purpose filter for gas and high flow fluid systems

Strong welded steel construction housing features DN80 or DN100 connections. Several media options including PED 3 classified versions for gas applications. As options available safety filter to secure filtration even in by pass situations, and differential pressure indicator for accurate operation control.



Contact Information:

Parker Hannifin
Hydraulic Filter Division Europe

European Product
Information Centre
Freephone: 00800 27 27 5374
(from AT, BE, CH, CZ, DE, EE, ES,
FI, FR, IE, IT, PT, SE, SK, UK)
filtrationinfo@parker.com

www.parker.com/hfde

Applications:

- Lubricating oil filter for industrial systems
- Gas fine filter for combustion engines
- Fuel oil filter for high flow systems
- Large in line low-pressure filter for hydraulic systems

Specification

Assembly:

In-line filter, vertical installation or optionally horizontal installation. Includes 2 elements.

Maximum operating pressure:

10 bar

Nominal flow rate (30 cSt):

1400 l/min (84 m³/h)

Connections:

Flanges DN80/PN16 or DN100/PN16

Seal material:

Fluoroelastomer

Operating temperature:

-20°C...+120°C, with Fluoroelastomer seals,

-20°C...+160°C with metal mesh elements and Fluoroelastomer seals.

Housing material:

Steel or stainless steel

Weight:

100 kg

Bypass valve:

Standard without bypass. Optionally opening pressure 2.0 bar.

Filtration materials:

- Glassfibre Microglass III
- Resin impregnated cellulose paper 15 µm nominal
- Cleanable metal mesh

Indicator options:

Visual, electrical or electronic indicator requires an indicator block. For details see indicator options table in product description page and catalogue section 4.

Fluid compatibility:

Suitable for use with regular hydraulic and lubrication oils and fuel oils. For heavy fuel oil applications, please specify option P2 (see table 8 in product description) which ensures that filters are delivered with documentation according PED 97/23/EC category II. Respectively for combustible gas applications, specify option P3 for PED category III. For other fluids consult Parker Filtration.

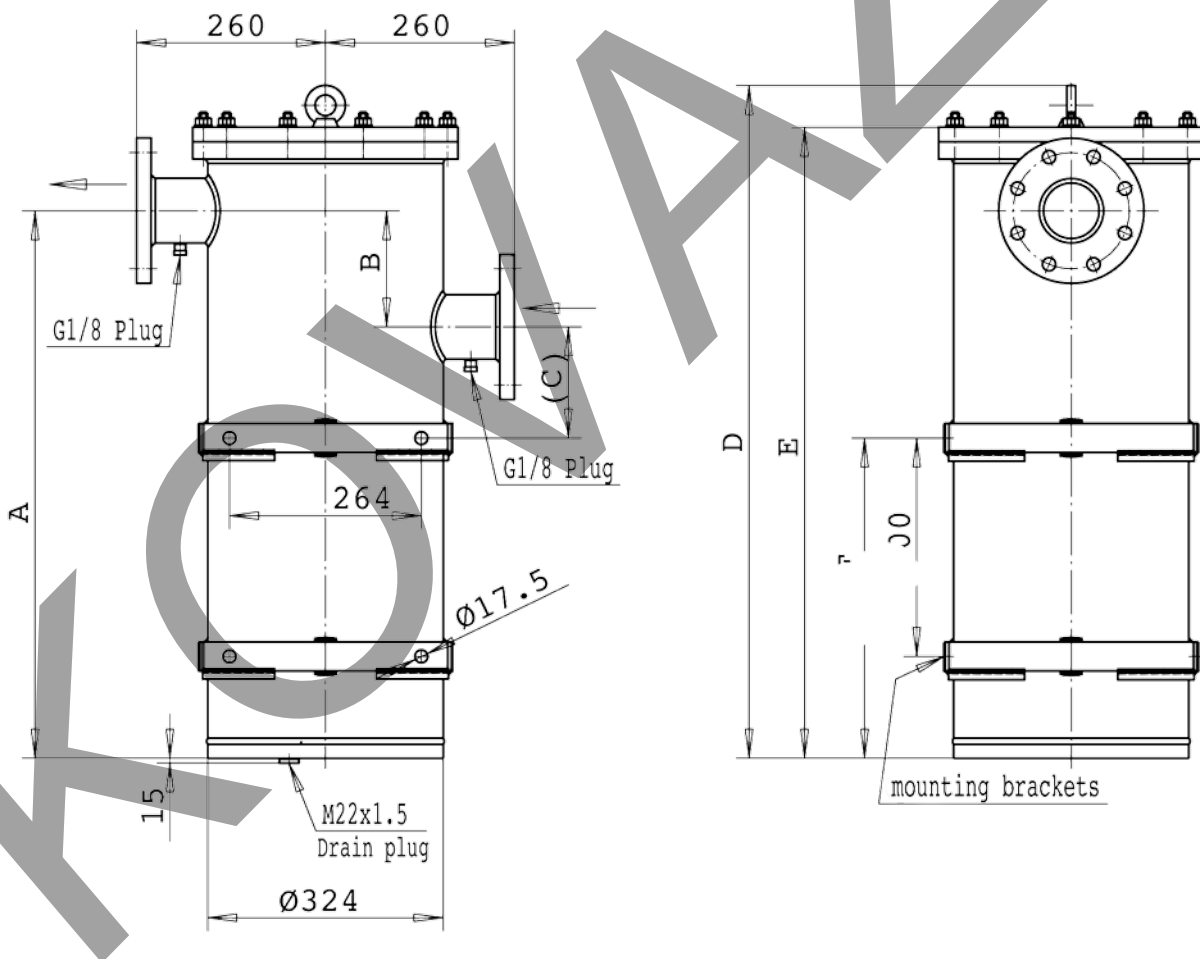

Type	A	B	C	D	E	F
DN80/PN16	753	160	153	932	868	440
DN100/PN16	786	186	140	978	914	460

SF1040 Series

Pressure Drop Curves

$$\Delta p_{\text{total}} = \Delta p_{\text{housing}} + \Delta p_{\text{element}}$$

The recommended level of the initial pressure drop for this filter is maximum 0.5 bar.

Δp -curves are measured at 30 cSt.

If the medium used has a viscosity different from 30 cSt, pressure drop over the element can be estimated as follows:

$$\Delta p_{\text{total}} = \Delta p_{\text{housing}} + \Delta p_{\text{element}} \times \frac{\text{working viscosity}}{30 \text{ cSt}}$$

SF1040 DN80/PN16 housing

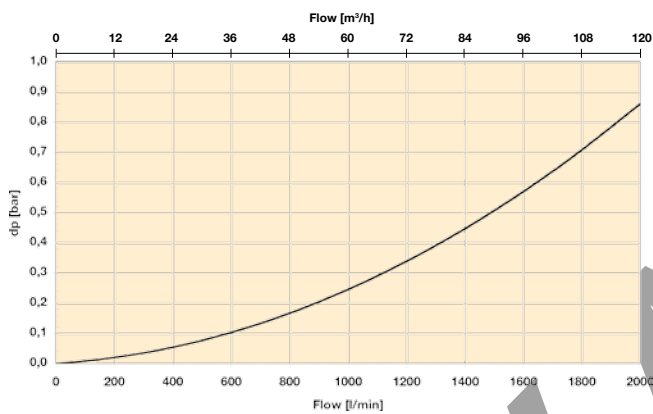

SF1040 element pack (2 pcs)

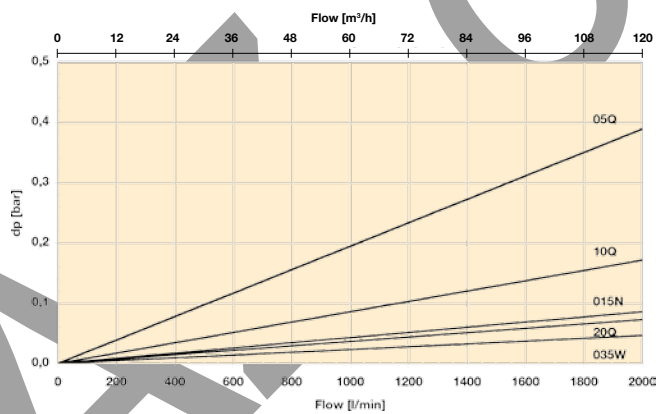

Product Description for SF1040

Complete Filter:

Table 1

--

Table 2

--

Table 3

--

Table 4

--

Table 5

--

Table 6

--

Table 7

--

Table 8

--

Table 1

FILTER TYPE	
Model	CODE
Single filter	SF1040
Stainless steel housing	SFR1040
Horizontal installation	SFH1040

Table 2

FILTER SIZE	
Length/elements	CODE
2 elements housing	2

Table 3

DEGREE OF FILTRATION	
Element type	CODE
Microglass III	
Glassfibre 5 µm	05Q
Glassfibre 10 µm	10Q
Glassfibre 20 µm	20Q
Other medias	
Cellulose 15 µm (nom)	015N
Cleanable metal mesh 35 µm	035W
Cleanable metal mesh 60 µm	060W

Table 4

SEAL TYPE	
Seal material	CODE
Fluoroelastomer	V

REPLACEMENT ELEMENTS

Media code	Order code
Glassfibre	Microglass III
05Q	939381Q
10Q	939382Q
20Q	939383Q
Cellulose 15 µm (nom)	
015N	939384
Cleanable metal mesh	
035W	939385
060W	939386

Table 5

INDICATORS	
Options	CODE
No indicator block	N
Indicator port plugged	P
Visual indicator	M3
Electrical indicator	T1
Electronic indicator (PNP/N.O.)	F1
Electronic indicator (NPN/N.O.)	F2
ATEX indicator PNP/N.O.	X1

Table 6

BYPASS VALVE	
Bypass/indicator setting	CODE
2.0 bar/1.5 bar	H
No/No	X

Table 7

FILTER CONNECTIONS	
Port size	CODE
DN80 T-port	D80T
DN80 C-port (both ports to same direction)	D80C
DN100 T-port	D100T

Table 8

OPTIONS	
Options	CODE
With bypass	1
No bypass	2
PED category 2	P2
PED category 3	P3
No mounting brackets	NB
Secondary element 60 µm	F

If several options are selected, please add the codes in order listed above.

SPARE PARTS

Seal kit	CODE
Seal material	
Fluoroelastomer	916045044
Secondary element	CODE
Wire mesh 60 µm	939377

Please note the bolded options reflect standard options with reduced lead-time.