

PL10 Lubricator – Standard

Symbols

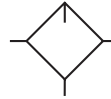

- Stainless steel construction handles most corrosive environments
- Fillable under pressure
- Meets NACE specifications MR-01-75/ISO 15156
- High flow: 1/2" - 47 dm³/s[§]
- 1/8" female threaded drain

Options:

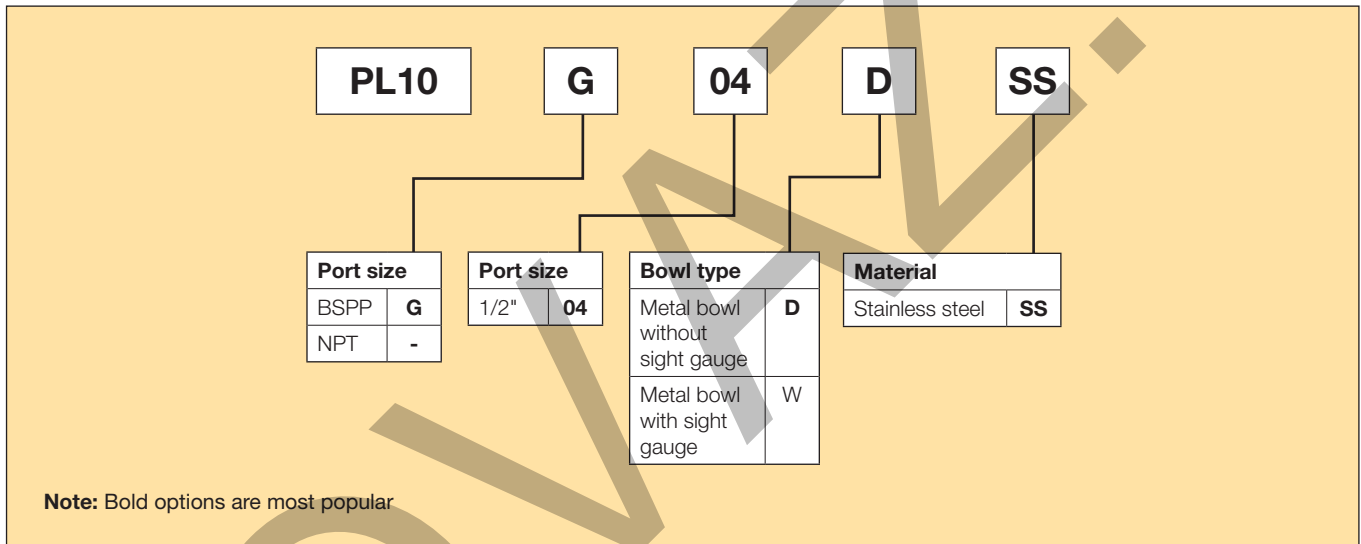

Port size	Description	Order code	Max bar	Height mm	Width mm	Depth mm
G1/2	BSP Manual twist drain - Metal bowl - Without sight gauge	PL10G04DSS	20.7	173	64	60
G1/2	NPT Manual twist drain - Metal bowl - Without sight gauge	PL10-04DSS	20.7	173	64	60
G1/2	BSP Manual twist drain - Metal bowl - With sight gauge	PL10G04WSS	17.2	173	64	60
G1/2	NPT Manual twist drain - Metal bowl - With sight gauge	PL10-04WSS	17.2	173	64	60

§ dm³/s = Flow at 6.2 bar and a 0.3 bar pressure drop

Specifications

Bowl capacity	118 cm ³	
Port threads	G1/2	
Operating temperature	Metal bowl (D)	-18°C to 66°C
	Metal bowl (W)	-18°C to 66°C
Max supply pressure	Metal bowl (D)	0 to 20.7 bar
	Metal bowl (W)	0 to 17.2 bar
Weight	850 g	

Note: Air must be dry enough to avoid ice formation at temperatures below 2°C.

Materials of Construction

Body	316 Stainless steel
Bowl	316 Stainless steel
Dip tube	316 Stainless steel
Drain	316 Stainless steel
Fill plug	316 Stainless steel
Seals	Flourocarbon
Sight dome	Nylon
Sight gauge	Isoplast

Dimensions (mm)

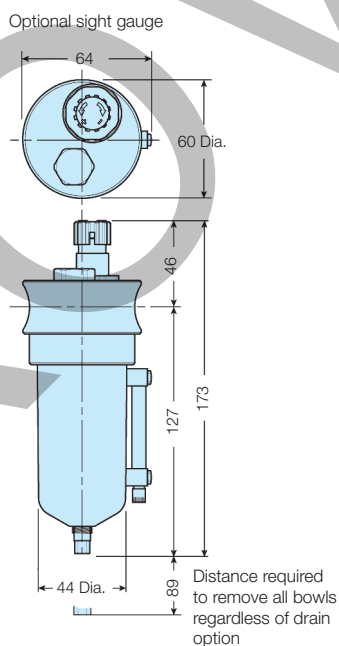

Flow Charts

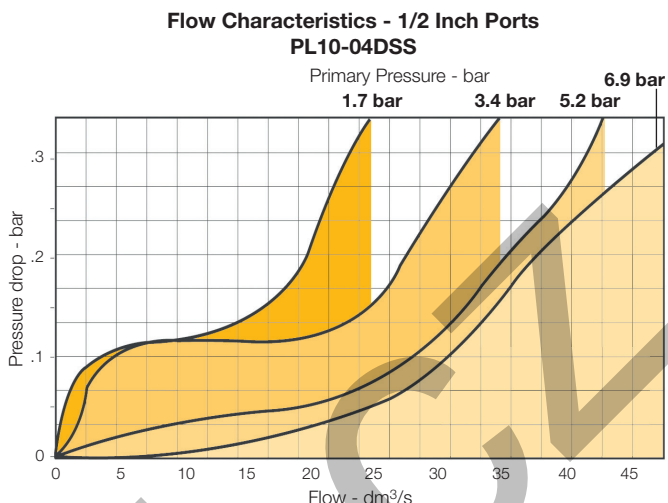

Accessories

Manual twist drain	Small (Old)	SA600Y7-1SS
	Large (New)	SAP05481
Pipe nipple	1/2" NPT 316 Stainless Steel	616A28-SS
	1/2" BSPT 316 Stainless Steel	AC-4SS
Sight dome kit		RKL10SS

Operation

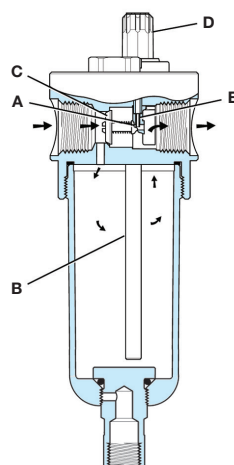

Air flowing through the unit goes through two paths. At low flow rates the majority of the air flows through the Venturi section (A). The rest of the air opens the check valve (C). The velocity of the air flowing through the Venturi section (A) creates a pressure drop. This lower pressure allows the oil to be forced from the reservoir through the pickup tube (B) and travels up to the metering screw (D). The rate of oil delivery is then controlled by adjusting the metering screw (D). Oil flows past the metering screw (D) and forms a drop in the nozzle tube (E). As the oil drops through the dome (F) and back into the Venturi section (A), it is broken up into fine particles. It is then mixed with the air flowing past the check valve (C) and is carried downstream. As the air flow increases the check valve (C) will open more fully. This additional flow will assure that the oil delivery rate will increase linearly with the increase of air flow.