

PJTM Series Male Thread Connector

Simple male connection for low profile positions secured to a plate or bracket. BSPP, NPT metric threads.
 Fitting material: aluminum.

Installation

Note:
 When installing cup assemblies, use a sealant material to secure the assembly and prevent vacuum leakage.

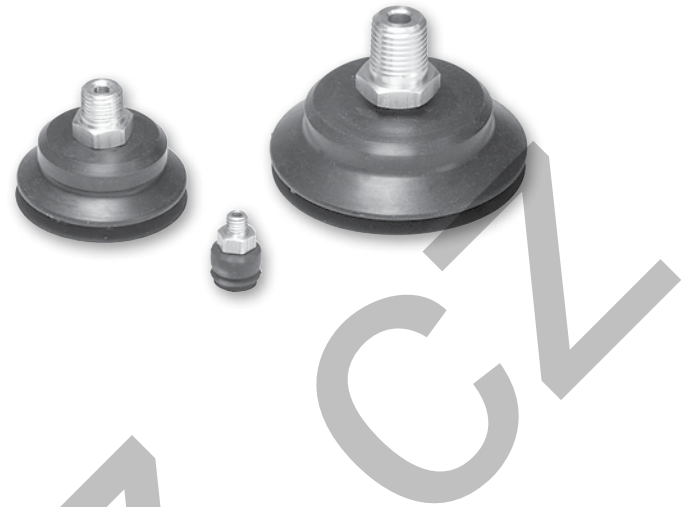
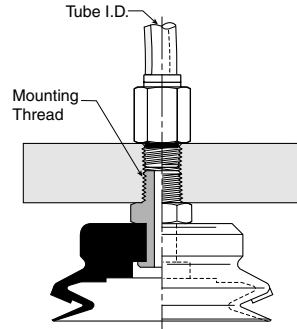

Cup diameter (mm)	Vacuum port	Complete assembly Nitrile	Replacement cup Nitrile (NB)	Complete assembly Silicon (SI)	Replacement cup Silicon (SI)	Replacement cup fitting
6	M5	PJTM-6-NBR-M5	PJG-6-NBR	PJTM-6-SI-M5	PJG-6-SI	FTM-5A-M5
6	1/8 BSPP	PJTM-6-NBR-G1	PJG-6-NBR	PJTM-6-SI-G1	PJG-6-SI	FTM-5A-G1
8	M5	PJTM-8-NBR-M5	PJG-8-NBR	PJTM-8-SI-M5	PJG-8-SI	FTM-5A-M5
8	1/8 BSPP	PJTM-8-NBR-G1	PJG-8-NBR	PJTM-8-SI-G1	PJG-8-SI	FTM-5A-G1
10	M5	PJTM-10-NBR-M5	PJG-10-NBR	PJTM-10-SI-M5	PJG-10-SI	TN-PF-15-M5
15	M5	PJTM-15-NBR-M5	PJG-15-NBR	PJTM-15-SI-M5	PJG-15-SI	TN-PF-15-M5
20	M5	PJTM-20-NBR-M5	PJG-20-NBR	PJTM-20-SI-M5	PJG-20-SI	TN-PF-20-M5
30	1/8 BSPP	PJTM-30-NBR-G1	PJG-30-NBR	PJTM-30-SI-G1	PJG-30-SI	FTM-20B-G1
30	1/4 BSPP	PJTM-30-NBR-G2	PJG-30-NBR	PJTM-30-SI-G2	PJG-30-SI	FTM-20B-G2
30	M10	PJTM-30-NBR-M10	PJG-30-NBR	PJTM-30-SI-M10	PJG-30-SI	FTM-20B-M10
30	1/8 NPT	PJTM-30-NBR-N1	PJG-30-NBR	PJTM-30-SI-N1	PJG-30-SI	FTM-20B-N1
40	1/8 BSPP	PJTM-40-NBR-G1	PJG-40-NBR	PJTM-40-SI-G1	PJG-40-SI	FTM-20B-G1
40	1/4 BSPP	PJTM-40-NBR-G2	PJG-40-NBR	PJTM-40-SI-G2	PJG-40-SI	FTM-20B-G2
40	M10	PJTM-40-NBR-M10	PJG-40-NBR	PJTM-40-SI-M10	PJG-40-SI	FTM-20B-M10
40	1/8 NPT	PJTM-40-NBR-N1	PJG-40-NBR	PJTM-40-SI-N1	PJG-40-SI	FTM-20B-N1
50	1/8 BSPP	PJTM-50-NBR-G1	PJG-50-NBR	PJTM-50-SI-G1	PJG-50-SI	FTM-50-G1
50	1/4 BSPP	PJTM-50-NBR-G2	PJG-50-NBR	PJTM-50-SI-G2	PJG-50-SI	FTM-50-G2
50	1/8 NPT	PJTM-50-NBR-N1	PJG-50-NBR	PJTM-50-SI-N1	PJG-50-SI	FTM-50-N1
60	1/4 BSPP	PJTM-60-NBR-G2	PJG-60-NBR	PJTM-60-SI-G2	PJG-60-SI	FTM-60-G2
60	M10	PJTM-60-NBR-M10	PJG-60-NBR	PJTM-60-SI-M10	PJG-60-SI	FTM-60-M10
60	1/4 NPT	PJTM-60-NBR-N2	PJG-60-NBR	PJTM-60-SI-N2	PJG-60-SI	FTM-60-N2
80	1/4 BSPP	PJTM-80-NBR-G2	PJG-80-NBR	PJTM-80-SI-G2	PJG-80-SI	FTM-60-G2
80	M10	PJTM-80-NBR-M10	PJG-80-NBR	PJTM-80-SI-M10	PJG-80-SI	FTM-60-M10
80	1/4 NPT	PJTM-80-NBR-N2	PJG-80-NBR	PJTM-80-SI-N2	PJG-80-SI	FTM-60-N2

Dimensions

PJTM-6 and
PJTM-8

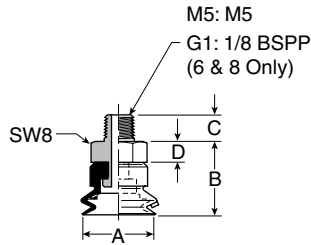

PJTM-10 thru
PJTM-20

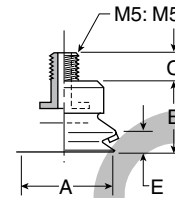

PJTM-30 thru
PJTM-50

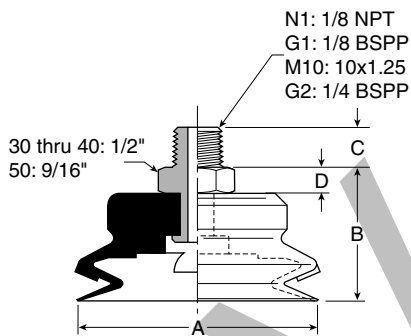

PJTM-60 thru
PJTM-80

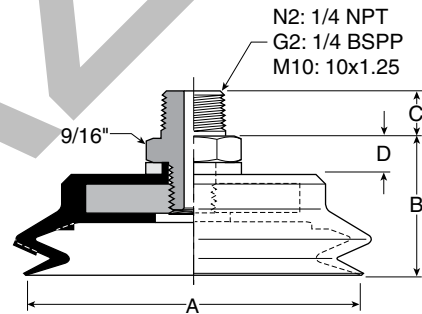

Dimensions (mm)

Model number	ØA	B	C (M5)	C (N1 / G1)	C (M10 / G2)	C (N2)	D
PJTM-6-*†	6	12,5	4,5	8	—	—	3,5
PJTM-8-*†	8	12,5	4,5	8	—	—	3,5
PJTM-10-*†	10	9,5	5	—	—	—	—
PJTM-15-*†	15	11	5	—	—	—	—
PJTM-20-*†	20	13	5	—	—	—	—
PJTM-30-*†	30	23	—	8	10	—	5
PJTM-40-*†	40	23	—	8	10	—	5
PJTM-50-*†	50	25	—	8	10	—	5
PJTM-60-*†	60	27	—	—	10	15	7
PJTM-80-*†	80	28	—	—	10	15	7

* Cup material
† Thread size

