

Features

- Double sealing lips for flexible sheet handling
- Vacuum cup grooves on underside increase holding area
- Resists acceleration and deceleration shear forces
- Strong low profile for fast response
- Metal insert fitting for stable vertical and horizontal lifts

Applications

These suction cups are ideal for applications where the product may flex when being lifted. All cups have a double sealing lip and cleats to increase holding capacity. The top of the cup has a ribbed outer lip to prevent it from rolling over the surface to be lifted.

Dual sealing lips provide 2 seals for vacuum. As the product flexes, the outer lip seal may break, but the inner lip seal will hold the degree of vacuum for continued lifting capacity. In these types of applications, sizing should be done on the inner diameter cup dimension.

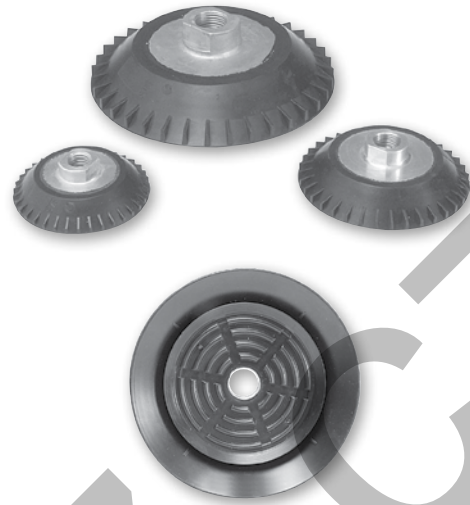

Cup diameter (mm)	Vacuum port	Complete assembly Nitrile (NBR)	Area*** cm ²	Cup volume (V) liters	Deflection (S) (mm)	Radius R (mm)	
						R1*	R2**
50	1/8 BSPP	P5V-CFS05011N	19.6	.001	4	98	80
100	3/8 BSPP	P5V-CFS10013N	78.5	.0667	8	254	161
150	1/2 BSPP	P5V-CFS15014N	176.7	.2083	11	309	252

* Minimum permissible radius for lifting using inner lip.

** Minimum permissible radius for lifting using outer lip.

*** Area based on outer cup diameter

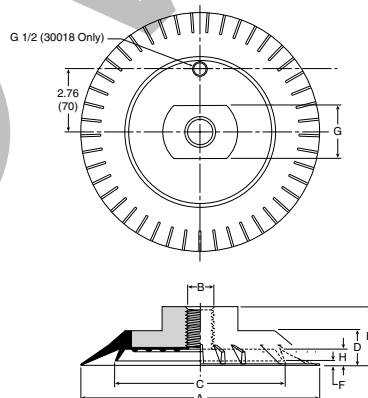
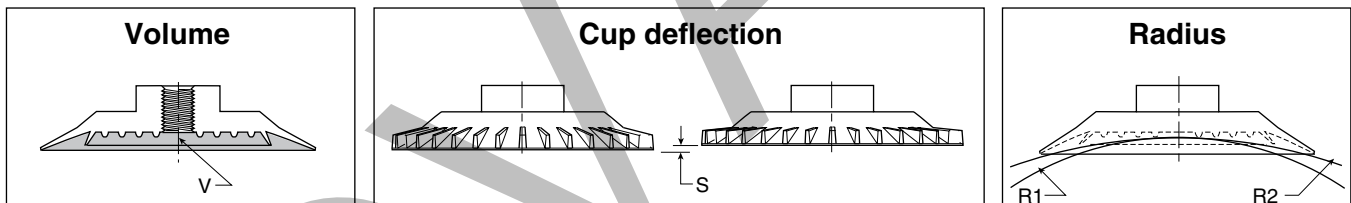

Dimensions (mm)

Model number	ØA	B	ØC	D	E	F	G	H
P5V-CFS50*	50	G1/8	35	11	18	2.2	13	3.7
P5V-CFS100*	100	G3/8	72	18	28	5	22	7.5
P5V-CFS150*	150	G1/2	106	26	42	7	27	11

* Cup material