

Coalescing Filters



- Extended high efficiency filter element provides greater filtration surface area.
- Integral 3/4 or 1" ports (BSPP & NPT)
- Removes liquid aerosols and sub micron particles
- Oil free air for critical applications, such as air gauging, pneumatic instrumentation and control

Note: To optimise the life of the coalescing element, it is advisable to install a P3YFA pre-filter with a 5 micron element upstream of the coalescing filter.

Options:

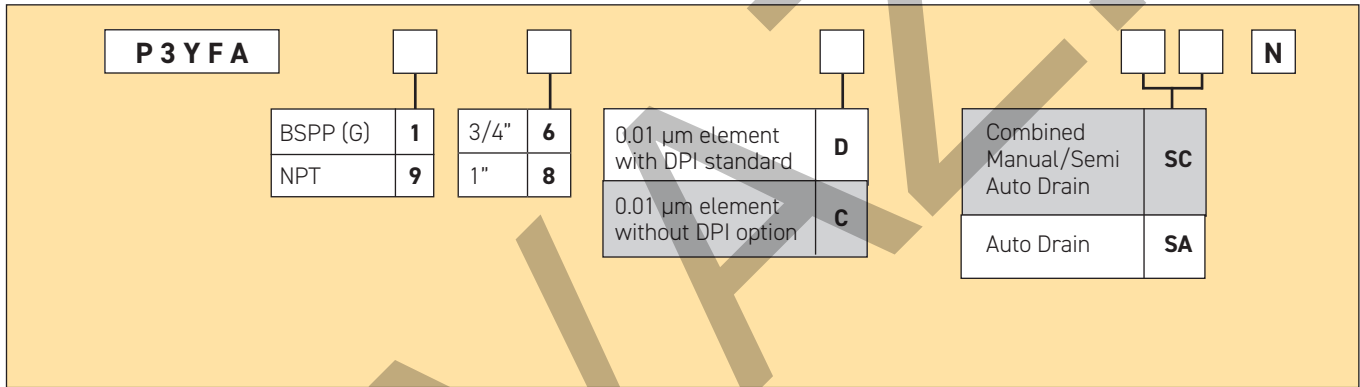

Port size	Description	Order Code	Flow dm ³ /s *	Max bar	Min temp °C	Max temp °C	Bowl capacity cm ³	Height mm	Width mm	Depth mm	Weight kg
3/4	Coalescing Filter 0.01µm, Combined manual/semi auto drain	P3YFA16DSCN	177	17.5	-10	60	130	340	90	94	1.6
3/4	Coalescing Filter 0.01µm, auto drain	P3YFA16DSAN	177	17.5	-10	60	130	340	90	94	1.6
1"	Coalescing Filter 0.01µm, Combined manual/semi auto drain	P3YFA18DSCN	145	17.5	-10	60	130	340	90	94	1.6
1"	Coalescing Filter 0.01µm, auto drain	P3YFA18DSAN	145	17.5	-10	60	130	340	90	94	1.6

* flow with 6,3 bar inlet pressure and 0,2 pressure drop

Technical Information

Fluid:	Compressed air
Maximum inlet pressure*:	17.5 bar
Temperature range*:	-10°C to +60°C
Media specifications:	
Coalescing efficiency	(0.3 to 0.6 micron particles): 99.97%
Max. oil carryover (PPM w/w):	0.008 mg/m ³
Typical flow element @ 6,3 bar inlet pressure and 0.2 bar pressure drop:	Dry element 0.01µm @ 59dm ³ /s
Manual/Semi-auto drain:	Bowl pressure to close drain 0.8 bar G1/8" thread
Auto drain:	
bowl pressure to close drain	0.8 bar
Operating range manual override facility (depress pin)	0.8 to 17.5 bar Ø 10mm brass connection
Bowl sump capacity:	130 cm ³

* Air supply must be dry enough to avoid ice formation at temperatures below +2°C

Material Specification

Body:	Aluminium
Sight glass:	Polypropylene
Filter cover:	ABS
Coalescing element:	Borosilicate & Nano fibres
Top & bottom end cap:	Aluminium
Support cylinders:	Grade 430 stainless steel
Support media:	Polypropylene
Anti re-entrainment barrier:	Polyester
Ensapulate:	Epoxy resin / Hardener
Seals:	Nitrile NBR
Drains:	Manual / Semi-auto: Acetal Automatic: PA / Brass connection
Differential pressure indicator materials:	
Body:	Acetal
Internal parts:	Acetal
Spring:	Stainless steel
Seals:	Nitrile NBR
Support plate	ABS
Screws	Steel / zinc plated

Dimensions (mm)

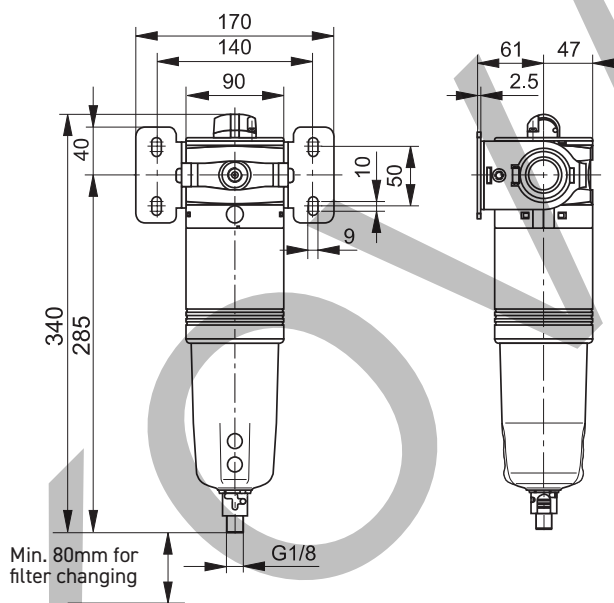

Flow characteristics

(3/4") 0.01µm Coalescing Filter Saturated

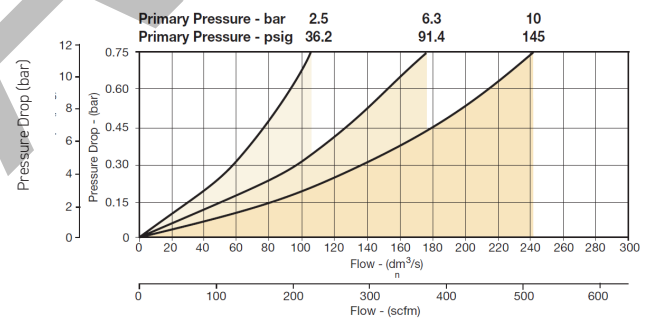

(1") 0.01µm Coalescing Filter Saturated

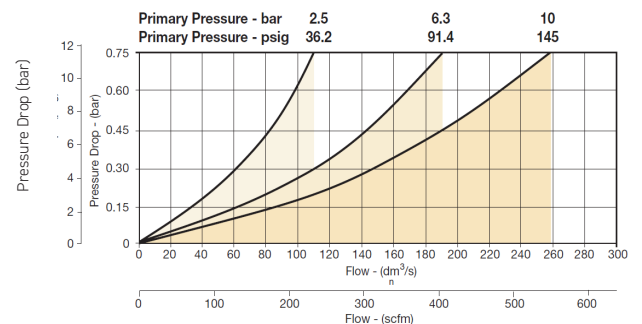

Service kits

Description	Order code
0.01 micron coalescing element kit	P3YKA00ESC
Bowl kit with combined manual/semi auto drain	P3YKA00BSC
Bowl kit with auto drain	P3YKA00BSA
Differential pressure indicator kit	P3YKA00RQ

Adsorber Filter



- Integral 3/4 or 1" ports (BSPP & NPT)
- Adsorber activated carbon element removes oil vapours and most hydrocarbons

Note: To optimise the life of the adsorber element, it is advisable to install a P3Y coalescing 0.01 µm filter upstream of the adsorber filter.

Options:

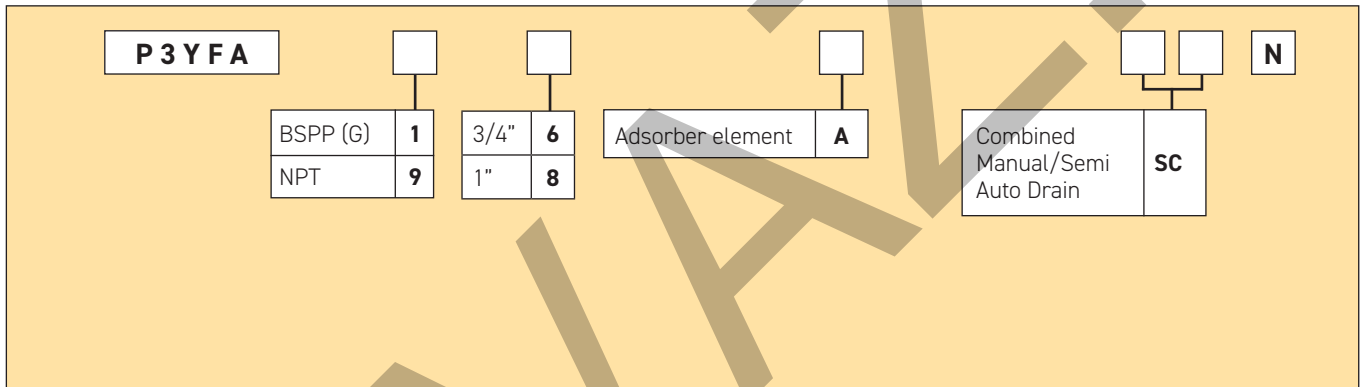

Port size	Description	Order Code	Flow dm ³ /s *	Max bar	Min temp °C	Max temp °C	Bowl capacity cm ³	Height mm	Width mm	Depth mm	Weight kg
3/4	Adsorber Filter, Combined Manual/Semi Auto drain	P3YFA16ASCN	177	17.5	-10	60	130	340	90	94	1.5
1"	Adsorber Filter, Combined Manual/Semi Auto drain	P3YFA18ASCN	145	17.5	-10	60	130	340	90	94	1.5

* flow with 6,3 bar inlet pressure and 0,2 pressure drop

Technical Information

Fluid:	Compressed air	
Maximum inlet pressure*:	17.5 bar	
Temperature range*:	-10°C to +60°C	
Media specifications:		
Max. oil carryover (PPM w/w):	0.008 mg/m ³	
Typical flow at 6,3 bar inlet pressure and 0.2 bar pressure drop:	1" Adsorber	50 dm ³ /s
Manual drain / Semi-auto drain:	G1/8" thread	
Bowl sump capacity:	130 cm ³	

* Air supply must be dry enough to avoid ice formation at temperatures below +2°C

Material Specification

Body:	Aluminium
Sight glass:	Polypropylene
Filter cover:	ABS
Adsorber element:	Activated carbon
Top & bottom endcap:	Glass filled nylon
Seals:	Nitrile NBR
Bayonet support:	Nylon
Drain: Manual / Semi-auto:	Acetal

Dimensions (mm)

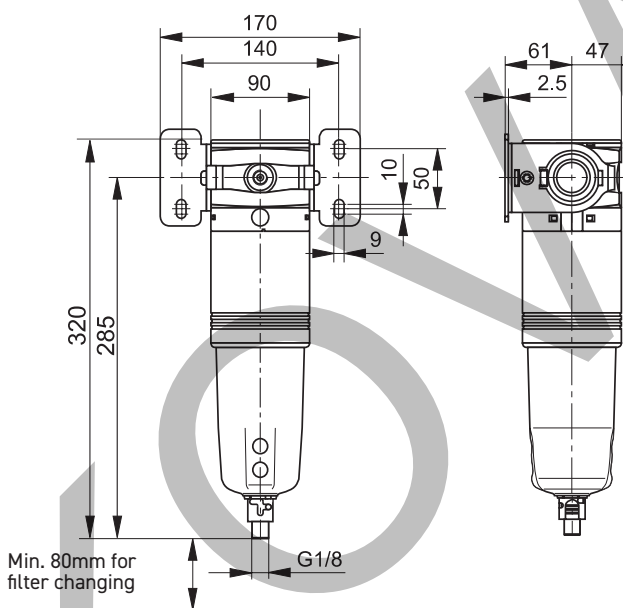

Flow characteristics

(3/4") Adsorber Filter

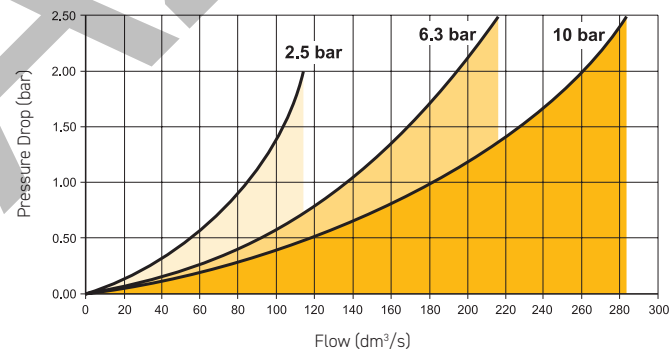

(1") Adsorber Filter

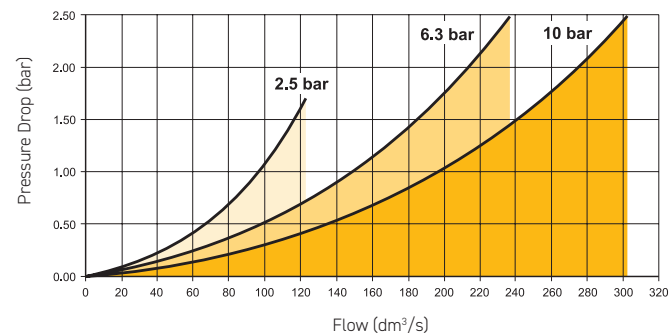

Service kits

Description	Order code
Adsorber element kit	P3YKA00ESA
Bowl kit with manual / semi-auto drain	P3YKA00BSC