

P33 Regulators – Standard

- Integral 1/2" or 3/4" ports (NPT, BSPP & BSPT)
- Robust but lightweight aluminum construction
- Secondary pressure ranges
- Secondary aspiration plus balanced poppet provides quick response and accurate pressure regulation
- Relieving & non-relieving types
- Non-rising knob

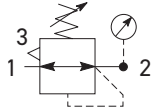

Self relieving regulator with gauge

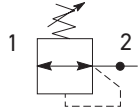

Non-relieving regulator

Port Size	Description (relieving)	Gauge	Part Number
1/2"	125 psig (8 bar)	None	P33RA14BNNP
3/4"	125 psig (8 bar)	None	P33RA16BNNP

Operating Information

Flow capacity*: 1/2, 3/4 233 scfm (110 dm³/s, ANR)
 Operating temperature: -13°F to 150°F (-25°C to 65.5°C)
 Supply pressure (max): 300 psig (20 bar)
 Adjusting range pressure: 0 to 30 psig (0 to 2 bar)
 0 to 60 psig (0 to 4 bar)
 0 to 125 psig (0 to 8 bar)
 0 to 250 psig (0 to 17 bar)
 Gauge port (2 each): 1/4 NPT, BSPP, BSPT
 Weight: 1.37 lb (0.62 kg)
 * Inlet pressure 145 psig (10 bar). Secondary pressure 91.3 psig (6.3 bar) and 14.5 psig (1 bar) pressure drop.

Ordering Information:

P33RA	1	6	B	N	G	P
Basic Series Global Modular Standard Regulator P33RA	Thread Type BSPP 1 BSPT 2 NPT 9	Port Size 1/2 4 3/4 6	Relief Relieving B Non-Relieving N Reverse Flow-Relieving R	Adjustment Non-Rising Knob N	Adjustment Range With Round Gauge Z 30 psig; 2 bar; 0.2 MPa M 60 psig; 4 bar; 0.4 MPa G 125 psig; 8 bar; 0.8 MPa J 250 psig; 17 bar; 1.7 MPa Without Gauge Y 30 psig; 2 bar; 0.2 MPa L 60 psig; 4 bar; 0.4 MPa N 125 psig; 8 bar; 0.8 MPa H 250 psig; 17 bar; 1.7 MPa	Mounting P Plastic Panel Mount Nut

Most Popular



Material Specifications

Body	Aluminum
Adjustment knob	Acetal
Body cap	ABS
Bonnet	Glass-filled nylon
Diaphragm assembly	Nitrile / zinc
Valve assembly	Brass / nitrile
Springs	Steel, stainless steel
Seals	Nitrile
Panel nut	Acetal

Repair and Service Kits

Diaphragm repair kit - relieving	P33KA00RB
Diaphragm repair kit - non-relieving	P33KA00RC
Panel mount nut - aluminum	P33KA00MM
Panel mount nut - plastic	P33KA00MP
Angle bracket (attaches via panel nut)	P33KA00MR
T-bracket with body connector	P32KA00MT
T-bracket	P32KA00MB
Body connector	P32KA00CB

Flow Charts

P33RA 1/2" Regulator

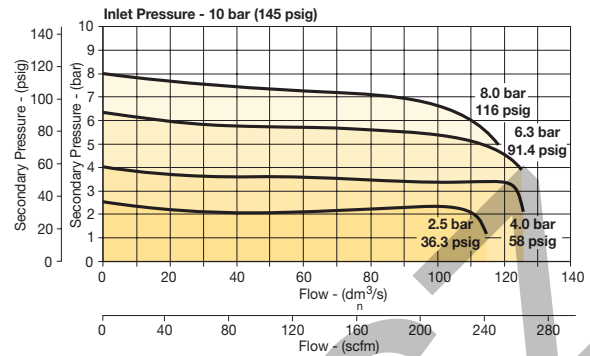

P33RA 3/4" Regulator

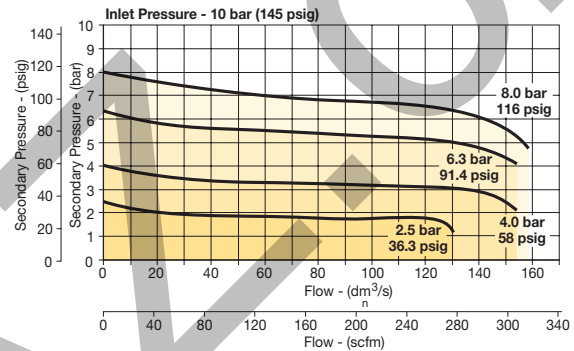

WARNING

Product rupture can cause serious injury.
Do not connect regulator to bottled gas.
Do not exceed Maximum primary pressure rating.

Gauges

50mm (2") round 1/4" center back mount	0-60 psig / 0-4 bar	P6G-ERB2040
	0-160 psig / 0-11 bar	P6G-ERB2110
	0-300 psig / 0-20 bar	P6G-ERB2240

For best performance, regulated pressure should always be set by increasing the pressure up to the desired setting.

CAUTION:

REGULATOR PRESSURE ADJUSTMENT - The working range of knob adjustment is designed to permit outlet pressures within their full range. Pressure adjustment beyond this range is also possible because the knob is not a limiting device. This is a common characteristic of most industrial regulators, and limiting devices may be obtained only by special design. For best performance, regulated pressure should always be set by increasing the pressure up to the desired setting.

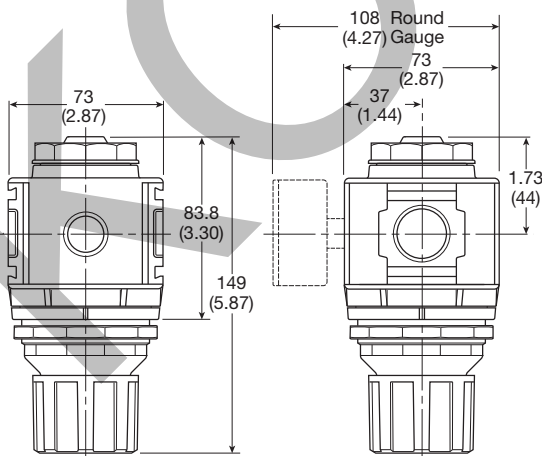

mm (Inches)

NOTE: 2.40 in. (61mm) hole required for panel nut mounting.

Most Popular

