

2022
EDITION



General Catalogue

Solenoid Valves for Fluid Control



ENGINEERING YOUR SUCCESS.

Who we are?

The Fluid Control Solutions Europe (FCSE) Business Unit is part of the Fluid and Climate Controls Division Europe (FCCE) of Parker Hannifin, the global leader in Motion and Control Technologies. FCSE core competences are the development and manufacturing of an extremely diverse range of fluid control products, including solenoid valves and pressure regulators.

Where we are?

Our European headquarters are located in Gessate (Milan-Italy) , this is also where our R&D, Marketing, Application Support and Product Management functions are located. Our Products are mainly manufactured in Gessate (Milan - Italy). The Parker Sales Companies and comprehensive distribution network support you, wherever you are.

History

Parker FCSE has been a leading player in the manufacturing and development of solenoid valve technologies for over 60 years, with continuous research and development bringing innovative solutions to the marketplace, for example leading the way in the utilisation of synthetic ruby for critical water applications or the unsurpassed reliability and precision of our pressure regulators. The expertise accumulated and developed through the years is evident in the superior quality of FCSE solutions.

Markets

Our products and solutions are typically designed for markets including Industrial Equipment, Industrial Automation, Mobile, Transportation, Life Sciences, Beverage dispensing and for Fluid and Process Control.

Benefits

The modular concept of our products, having separate solenoid valves and electrical parts, provides the customer with increased flexibility by allowing numerous combinations. This additional flexibility can enable distributors to greater reduce valve inventory levels, whilst retaining the same number of capabilities. Parker also has unrivalled experience in developing customised product solutions complying with the highest technical, environmental, energy and service life requirements.



WARNING - USER RESPONSIBILITY

FAILURE OR IMPROPER SELECTION OR IMPROPER USE OF THE PRODUCTS DESCRIBED HEREIN OR RELATED ITEMS CAN CAUSE DEATH, PERSONAL INJURY AND PROPERTY DAMAGE.

- This document and other information from Parker-Hannifin Corporation, its subsidiaries and authorized distributors provide product or system options for further investigation by users having technical expertise.
- The user, through its own analysis and testing, is solely responsible for making the final selection of the system and components and assuring that all performance, endurance, maintenance, safety and warning requirements of the application are met. The user must analyze all aspects of the application, follow applicable industry standards, and follow the information concerning the product in the current product catalog and in any other materials provided from Parker or its subsidiaries or authorized distributors.
- To the extent that Parker or its subsidiaries or authorized distributors provide component or system options based upon data or specifications provided by the user, the user is responsible for determining that such data and specifications are suitable and sufficient for all applications and reasonably foreseeable uses of the components or systems.

ORGANIZATION OVERVIEW



FCSE HEADQUARTER - GESSATE (MI) - ITALY

GENERAL CATALOGUE FCSE

TABLE OF CONTENT

INTRODUCTION

A complete range of solenoid valves.....	06
A modular concept.....	08
ATEX Certification.....	10
World class standards.....	11
How to use this catalogue.....	12
How to select a valve.....	14
How to order.....	16
How to use coil groups.....	18

2 WAY VALVES

Valves for dry or lubricated air, neutral gases and liquids.....	21
Valves for water and neutral liquids.....	61
Anti water hammer valves.....	89
Hot water and steam valves.....	101
Valves for hydraulic oil and neutral liquids (up to 100 bar).....	111
High corrosion resistant valves (303 Stainless Steel).....	127
High corrosion resistant valves (316L Stainless Steel).....	143
Oil burner valves.....	155
Fast switching valves.....	167

3 WAY VALVES

Valves for dry or lubricated air, neutral gases and liquids.....	171
Valves for hydraulic oil and neutral liquids (up to 75 bar).....	209
High corrosion resistant valves (303 Stainless Steel).....	213
Valves for beverage dispensing - Liquipure®.....	219

2 & 3 WAY VALVES FOR TRANSPORTATION

2 way.....	233
3 way.....	239

5 WAY DISTRIBUTORS FOR PNEUMATIC APPLICATIONS

5 way pneumatic distributors (Pipe mounting/Sub-base mounting).....	243
---	-----

3 & 5 WAY PNEUMATIC DISTRIBUTORS FOR ACTUATION CONTROL

3 & 5 way pneumatic valves for actuator control (Pipe mounting).....	269
3 & 5 way pneumatic valves for actuator control (NAMUR).....	301
316L Stainless Steel 3 & 5 way valves for actuator control (Pipe mounting and NAMUR)	343

ELECTROPNEUMATIC PRESSURE REGULATORS

EPP4 Series - Basic, Comfort , Comfort ATEX Ranges.....	379
---	-----

COILS, HOUSINGS & ELECTRICAL PARTS

Introduction.....	411
Coils.....	413
Explosion Proof Electrical Parts	443
Housings.....	473
Coil Accessories.....	478
Explosive Environments.....	480
Guidance Chart for IS-Barriers.....	490

TECHNICAL INFORMATION ABOUT SOLENOID VALVES

Technical information about solenoid valves.....	492
--	-----

APPENDIX

Table of sub-bases for valves.....	513
Table of voltage codes for coils and electrical parts.....	514
Index by Coil Reference.....	518
Index by Coil Group.....	520
Index by Valve reference.....	522
Index for Valves.....	524

A COMPLETE RANGE OF SOLENOID VALVES FOR FLUID CONTROL

2 WAY VALVES

- For dry or lubricated air, neutral gases and liquids
- For water and neutral liquids
- Anti water hammer
- Hot water and steam
- For hydraulic oil and neutral liquids (Max. 100 bar)
- High corrosion resistant (303 Stainless Steel) (316L Stainless Steel)
- Oil burner
- Fast switching
- Liquipure® for beverage dispensing



3 WAY VALVES

- For dry or lubricated air
- For hydraulic oil and neutral liquids (Max. 75 bar)
- High corrosion resistant (303 Stainless Steel)
- Liquipure® for beverage dispensing



2 & 3 WAY VALVES FOR TRANSPORTATION

- 2 way- direct and piloted
- 3 way- direct operated



3&5 WAY DISTRIBUTORS FOR PNEUMATIC APPLICATIONS

- Pipe mounted/ Sub-base mounting



3 & 5 WAY PNEUMATIC DISTRIBUTORS FOR ACTUATION CONTROL

- Pipe mounted
- NAMUR interface
- 316L Stainless Steel (Pipe mounted and with NAMUR interface)



COILS & ELECTRICAL PARTS

- Coils
- Housings
- Explosion-Proof Electrical Parts



EPP4 SERIES ELECTROPNEUMATIC PRESSURE REGULATORS

- Basic
- Comfort
- Comfort ATEX



A MODULAR CONCEPT FOR EVERY APPLICATION

CHOOSE BETWEEN:

Actuation Modes

- Direct Operated
- Magnalift
- Pilot Operated
- Manual Reset
- Externally Operated

Material Types

- Brass
- 303 Stainless St.
- 316L Stainless St.
- Anodized Aluminium
- Zinc Alloy
- POM

Mounting Solutions

- Pipe
- Sub-base
- NAMUR
- Banjo
- CETOP
- ISO

Control Functions

- Normally Closed
- Normally Open
- Universal
- Control by Electric Impulse
- Dual Solenoids
- PWM

Internal Design

- Piston
- Poppet
- Diaphragm
- Spool

Seals

- FKM
- NBR
- EPDM
- Ruby
- PUR
- PCTFE...

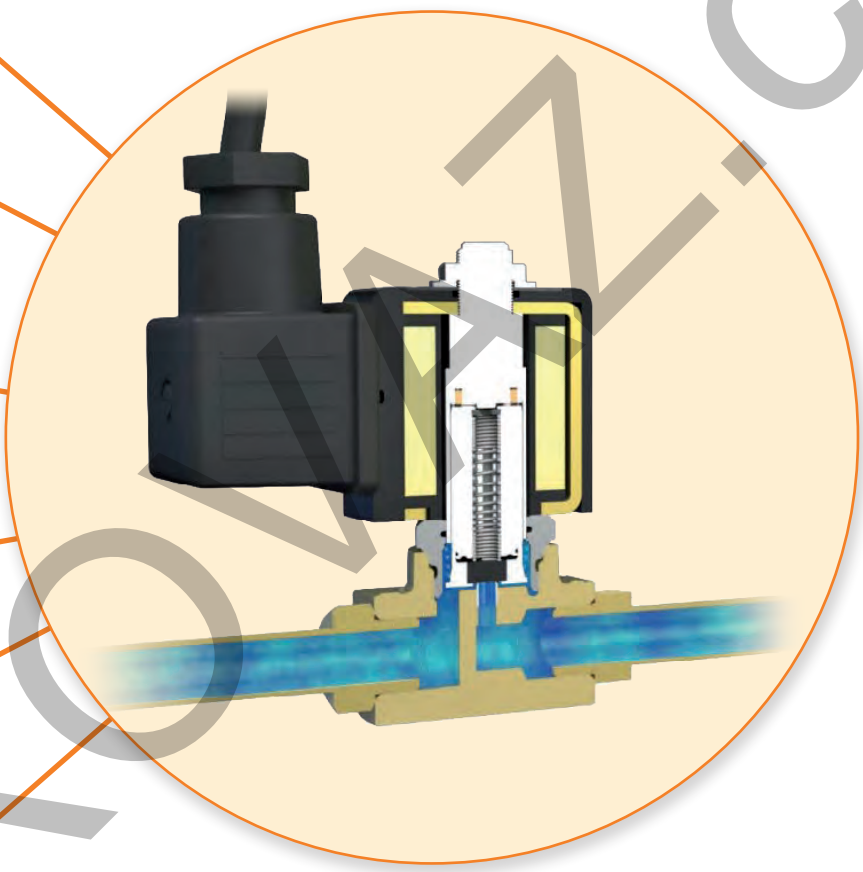

ATEX CERTIFICATION



ELECTRICAL PART ATEX CERTIFICATION

A selection of electrical parts conform to the terms of the 2014/34/EU directive and are made for potentially explosive environments - zone 0/20, 1/21 and 2/22.

Within the coil section, the presence of the ATEX logo  shows that the coil is ATEX approved.



PRESSURE VESSELS ATEX CERTIFICATION

A selection of pressure vessels conform to the terms of the 2014/34/EU directive specific to non electrical equipment for use within potentially explosive environments - zones 0/20, 1/21 and 2/22.

NAMUR & piped valve ranges now include a marking which indicates mechanical ATEX approval.

Within the valve section, the presence of the ATEX logo  shows that the valve is ATEX approved.

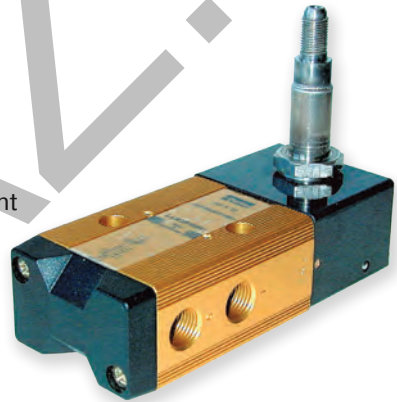

SOLENOID VALVE CERTIFICATION

When both the electrical and mechanical part are ATEX approved, the solenoid valve can be used in explosive atmospheres.

The solenoid valve can be delivered assembled and tested.

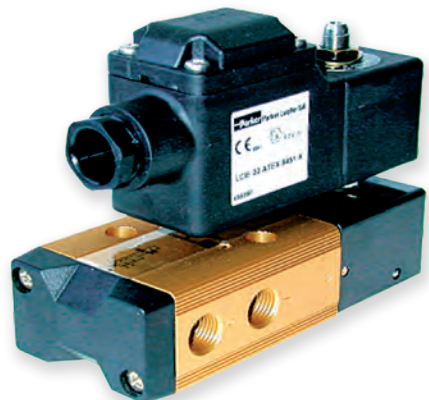

FCSE IS MEETING WORLD CLASS STANDARDS

QUALITY STANDARDS:

- ISO 9001
- ISO 14001
- OHSAS 18001
- ISO 45001 : 2018



CERTIFICATIONS AND APPROVALS:

Our products have been approved and are compliant with the relevant market requirements including:

- | | |
|-----------|----------|
| ● CE | ● AGA |
| ● ATEX | ● NEPSI |
| ● RoHS | ● KOSHA |
| ● UL | ● IMQ |
| ● REACH | ● NSF |
| ● IECEX | ● VDE |
| ● CSA | ● Ex EAC |
| ● DIN-TUV | ● UKCA |



HOW TO USE THIS CATALOGUE

This catalogue is a comprehensive list of Parker Solenoid Valves program. It will help to identify appropriate valves and coils and enable the user to generate ordering numbers.

This catalogue is split product range. You will find a summary page at the beginning of each valve section. For ease of use, each valve section is divided by application.

On the first page of each Application section, you will find an overview of the products within and their technical characteristics, to guide you to the relevant page (example below):

SECTION SUMMARY PAGE

2 WAY VALVES

VALVES FOR DRY OR LUBRICATED AIR, NEUTRAL GASES AND LIQUIDS

2/2

Actuation	Body	Function	Port Size	Orifice (mm)	Flow Factor Kv(Min)	Min. Inlet Pressure (bar)	Max. Fluid Temp. (°C)	Page Panel Valve	Page Panel Luer-Lock	
Direct Operated	Brass/Pipe mounting	Normally Closed	1/8"	1.2 to 3	4.5	70	140	26	32	
			1/4"	1.2 to 5	13	100	140	30	36	
			3/8"	4 to 6	12	10	120	-	36	
		Normally Open	1/8"	2.5	3.5	30	140	-	40	
			1/4"	1.5 to 3	4	40	140	-	40	
			3/8"	3 to 5	11	20	100	-	40	
	Magnalift	Brass/Sub-base mounting	Normally Closed	5 mm	1.5 to 3	4.5	100	130	-	42
				5 mm	1.5	3.5	20	120	-	44
				3/8"	13 to 15	65	20	140	48	48
		Brass/Pipe mounting	Normally Closed	1/2"	13 to 15	65	20	140	48	48
				3/4"	15 to 20	100	20	140	48	50
				1"	18 to 28	220	16	120	54	54
Pilot Operated	Brass/Pipe mounting	Normally Closed	1/4"	8 to 12	36	40	120	-	56	
			3/8"	11 to 13	50	40	120	54	58	
			1/2"	13 to 15	60	40	120	54	60	
		Normally Open	3/4"	15 to 20	135	40	120	54	62	
			1"	18 to 28	220	16	120	54	64	
			1 1/2"	40	425	16	120	-	66	
	Brass/Sub-base mounting	Normally Closed	2"	40	540	16	120	-	68	
			1/4"	8	36	40	140	-	70	
			3/8"	11 to 13	50	40	140	68	70	
		Normally Open	1/2"	13 to 15	60	40	140	68	70	
			3/4"	15 to 20	135	40	120	68	72	
			1"	25 to 40	420	16	120	68	72	
Control by Electric Impulse	Normally Closed	1 1/4"	28	270	16	120	-	72		
		1 1/2"	40	420	12	100	-	72		
		2"	40	540	12	120	-	74		
	Normally Open	1/4"	12	32	12	100	-	74		
		3/8"	12	45	12	100	-	74		
		1/2"	32	50	12	100	-	74		
Brass/Sub-base mounting	Normally Closed	1"	18	110	12	100	-	74		
		14 mm	14	45	40	140	-	76		
		Normally Open	14 mm	14	46	40	120	-	76	

Product range

Application

Number of ways / positions

Actuation

Applicable Fluids

Actuation, body and function

Body

Mounting

Function

Technical features

Related page

For further technical information regarding Actuation, Body and Function, please refer to the technical information section at the end of the catalogue.

Applicable Approvals within this page

Quick selection table with Min/Max values for all valves on the page

SECTION PRODUCT PAGE

2 WAY VALVES
21/2 VALVES FOR HYDRAULIC OIL AND NEUTRAL LIQUIDS (UP TO 100 BAR)
PILOT OPERATED

BRASS PIPE MOUNTING
NORMALLY CLOSED

Part No.	Orifice ID	Flow Factors	Operating Pressure Max (MPa)	Min (MPa)	Max (MPa)	Fluid Temp (°C)	Seal Mat.	Valve Mat.	Housing Mat.	Coil Mat.	Coil Group	Draw No.		
8	3/8"	2.16	1000	0.3	40	-25	+150	NBR	E321811	2965	481965	8	2.0	3523
8	3/8"	2.16	1000	0.3	40	-50	+100	NBR	E321811	4270	484000	8	2.0	3523
8	3/8"	2.16	1000	0.3	40	-50	+100	FKM	E321821	2965	481965	8	2.0	3523
8	3/8"	2.16	1000	0.3	40	-50	+100	FKM	E321821	4270	491900	8	2.0	3523
11	1/2"	3	2000	0.3	40	-50	+140	FKM	E321921	4270	482096	11	2.0	3523
11	1/2"	3	2000	0.3	40	-50	+100	NBR	E321913	4270	491900	11	2.0	3521
11	1/2"	3	2000	0.3	40	-50	+100	FKM	E321923	2965	491965	11	2.0	3521
11	1/2"	3	2000	0.3	40	-50	+140	FKM	E321923	4270	482096	11	2.0	3521
11	3/4"	3	2000	0.2	20	3	+140	FKM	E321603	2965	483516	11	2.0	3429
11	3/4"	3	2000	0.2	20	3	+140	FKM	E321603	4270	483516	11	2.0	3429
11	3/4"	3	2000	0.2	4	4	+150	FKM	E321603	482190	11	2.0	3429	

Notes:
 1 Minimum pressure differential = 0.3 bar for opening and 0 bar for closing.
 2 Check seal face compatibility table.

2 WAY VALVES

For this size	Part No.	Orifice Size	Kv (l/min)	MPa (Bar)	Fluid Temp (°C)
1/2"	3/8"	11	50	40	140

Ordering information
ISO 1219 Symbol
A choice of Coil Groups compatible with the selected valve.
Dimensional 2D* and 3D drawings

* 2D drawing shown always corresponds to the standard coil.

HOW TO SELECT A VALVE

Once you are in the selected range **1** and application **2** The table is designed to help you navigate to the products matching your criteria.

First decide the actuation **3**, then move across the table selecting your body material **4**, function **5** and technical requirements **6**.

After you have found products fitting within your specification, please go to the corresponding page number in the final column **7**, here you will find a selection of products that match your criteria.

1 SELECT PRODUCT FAMILY

2 SELECT APPLICATION

3 SELECT ACTUATION

4 SELECT BODY

5 SELECT FUNCTION

6 SELECT TECHNICAL DATA

7 SELECT CORRESPONDING PAGE

1

2 WAY VALVES

VALVES FOR DRY OR LUBRICATED AIR, NEUTRAL GASES AND LIQUIDS

2

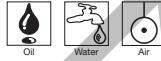

2/2

Actuation	Body	Function	Port Size	Orifice (mm)	Flow Factor Kv(l/min)	MOPD (bar)	Max Fluid Temp. (°C)	Page Parker Valves	Page Parker LUCIFER® Valves	
Direct Operated	Brass/Pipe mounting	Normally Closed	1/8"	1.2 to 3	4.5	70	140	28	32	
			1/4"	1.2 to 5	13	100	140	30	32	
			3/8"	4 to 6	12	10	120	-	36	
			1/2"	8.5 to 11	36	4	120	-	36	
			1/8"	2.5	3.5	30	140	-	40	
	Magnalift	Brass/Pipe mounting	Normally Open	1/4"	1.5 to 3	4	40	140	38	40
				1/4"	3 to 5	11	20	100	-	40
				5 mm	1.5 to 3	4.5	100	130	-	42
				5 mm	1.5	1.5	20	120	-	44
				3/8"	13 to 15	65	20	140	46	48
Pilot Operated		Brass/Pipe mounting	Normally Closed	1/2"	13 to 15	65	20	140	46	48
				3/4"	15 to 20	100	20	140	46	50
				1"	15 to 25	170	20	140	46	52
				1/4"	8 to 12	40	120	-	54	
				3/8"	11 to 13	50	120	-	54	
	Pilot Operated	Brass/Pipe mounting	Normally Open	1/2"	11 to 15	60	40	120	54	54
				3/4"	15 to 20	100	40	120	54	54
				1"	18 to 28	270	16	120	54	64
				1 1/2"	40	425	16	120	-	66
				2"	40	540	16	120	-	66
Pilot Operated		Brass/Pipe mounting	Control by Electric Impulse	1/4"	8	36	40	140	-	70
				3/8"	11 to 13	50	40	140	68	70
				1/2"	13 to 15	60	40	140	68	70
				3/4"	15 to 20	135	40	120	68	72
				1"	25 to 40	420	16	120	68	72
	Brass/Sub-base mounting	Normally Open	1 1/4"	28	270	16	120	-	72	
			1 1/2"	40	420	12	100	-	72	
			2"	40	540	12	120	-	72	
			1/4"	12	32	12	100	-	74	
			3/8"	12	45	12	100	-	74	
Brass/Sub-base mounting	Normally Closed	1/2"	12	50	12	100	-	74		
		3/4"	18	100	12	100	-	74		
		1"	18	110	12	100	-	74		
		14 mm	14	45	40	140	-	76		
		14 mm	14	46	40	120	-	76		



HOW TO ORDER PARKER SOLENOID VALVES

A SOLENOID VALVE IS COMPOSED OF 3 ELEMENTS:

The Valve ① + Housing ② + Coil ③

1. Choose the valve reference
2. Choose the housing
3. Choose the coil

① Choose the Valve Reference

Valve Ref.

121K3206

121K3206

121K3206

② Select the housing depending on the protection level (IP 44 to IP 67 found in the coil section)

Housing Ref.

2995

4270

4270

2 WAY VALVES

2/2 VALVES FOR DRY OR LUBRICATED AIR, NEUTRAL GASES AND LIQUIDS
DIRECT OPERATED

BRASS
PIPE MOUNTING
NORMALLY CLOSED



Port size	Orifice Ø	Flow factors		Operating Pressure Differential Max(MOPD)		Fluid Temp.		Seat Seal	Parker LUCIFER® Valves			Power		Coil Group	Dwg. No.		
		Kv l/min	Kv m³/h	AC bar	DC bar	Min	Max		Valve Ref.	Housing Ref.	Coil Ref.	AC W	DC W				
3/8"	4	7.5	0.45	480	0	10	4	-10	100	FRM	121K3206	2995	481865	8	9	2.0	3551
	4	7.5	0.45	480	0	10	5	-10	120	FRM	121K3206	4270	481000	8	8	2.0	3551
	4	7.5	0.45	480	0	10	10	-10	120	FRM	121K3206	4270	48265	14	14	2.0	3551
	5	11	0.66	750	0	7	2	-10	100	FRM	121K3106	2995	481865	8	9	2.0	3551
	5	11	0.66	750	0	7	2.8	-10	120	FRM	121K3106	4270	481000	8	8	2.0	3551
	5	11	0.66	750	0	7	5	-10	120	FRM	121K3106	4270	48265	14	14	2.0	3551
1/2"	6	12	0.72	1100	0	5	1.1	-10	100	FRM	121K3306	2995	481865	8	9	2.0/14.2	3551
	6	12	0.72	1100	0	5	1.5	-10	120	FRM	121K3306	4270	481000	8	8	2.0/14.2	3551
	6	12	0.72	1100	0	5	3	-10	120	FRM	121K3306	4270	48265	14	14	2.0/14.2	3551
	8.5	25	1.5	1600	0	1.1	0.5	-10	100	FRM	E121K46	2995	481865	8	9	2.0	3427
	8.5	25	1.5	1600	0	2.2	0.5	-10	120	FRM	E121K46	4270	481000	8	8	2.0	3427
	8.5	25	1.5	1600	0	4	1.2	-10	120	FRM	E121K46	4270	48265	14	14	2.0	3427
1/2"	11	36	2.16	2500	0	0.7	0.3	-10	100	FRM	E121K45	2995	481865	8	9	2.0	3427
	11	36	2.16	2500	0	1.2	0.35	-10	120	FRM	E121K45	4270	481000	8	8	2.0	3427
	11	36	2.16	2500	0	2.5	0.7	-10	120	FRM	E121K45	4270	48265	14	14	2.0	3427

Notes:
 1. Valve compatible with water only up to 40°C
 2. With manual override

Parker

36

For a given valve, several coil types are being suggested.

For a wider choice, the selected valve is also compatible with every other coil from the same coil group.

Parker coils are available in many different voltages.
Choose the one you need by putting the voltage code at the end of your ordering number.

3 Choose the coil and voltage code

Coil Ref.

481865

Voltage Code

VAC/Hz	Code
24/50	A2
48/50	A4
110/50	A5
220-230/50	3D

Valve and coil order example:

1

2

3

121K3206

2995

481865A2

Valve Reference

Housing

Coil and Voltage Code

COILS

COIL GROUP
2.0/2.1 COILS FOR DIN PLUG CONNECTION

COILS 32 mm

These coils can be mounted with every Parker solenoid valves corresponding to the specified Coil Group. See column "Coil Group" within valve pages.

This is an encapsulated assembly comprising a coil, integral magnetic iron path and snap-on plug connection.

The synthetic material encapsulation provides an effective compact housing, offering full protection against dust, oil, water, etc. Ease of mounting in confined space - offers shock and corrosion protection - simplifies conversion of existing equipment to other requirements, etc.

Coils conform to the IEC/ENEC safety standards and complies with European low-voltage directive.



Specification	Standard	Double frequency					
Ref. (without DIN plug)	481865	483510					
Ref. (with DIN plug)	482725	482635					
Coil Group	2.0 / 2.1						
Degree of protection	IP65 according to IEC / EN 60529 standards (with DIN plug).						
Class of insulation	F 155°C						
Electrical connection	The coil is connected with a 2 P + E plug according to EN 175301-803 type A						
Ambient temperature	-40°C to +50°C						
	The application is limited also by the temperature range of the valve.						
Elect. Power	DC Pn (pull)	9 W					
	P (hold) 20°C	12 W					
	AC Pn (holding)	8 W					
	Attraction cold	26 VA (9 W)					
Weight	130 g (without plug)						
Voltages "Un"	VAC/Hz	Code	VDC	Code	VAC/Hz	Code	
	-10% to +10% of the Un	24/50	A2	24	C2	24/50, 24/60	P0
		48/50	A4	48	C4	48/50, 48/60	S4
		110/50	A5	110	C5	110-115/50, 120/60	S5
	220-230/50	3D			220-240/50, 240/60	S6	

To Order a Coil choose Coil Ref + Voltage Code, example: 481865 for 24 VDC = **481865C2**

More voltage possibilities can be found in the table of voltage codes at the end of the coil section.

These coils must be used with suitable housings, see example below:

The coil assembly kit **Ref. 2995** corresponds to the "housing" of Lucifer™ valve numbering system (Valve - housing - coil/voltage). It is composed of a nameplate giving details of the valve type, a round washer and a nut to ensure the fixing between 32 mm coil and the valve.

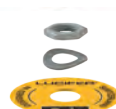
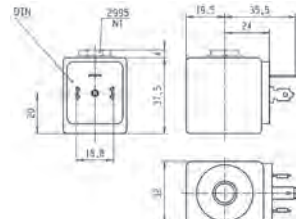
Parker

446

IMPORTANT: Valve, Housing or Coil shall be ordered separately. In case you would require configured products, please consult your Parker contact or the PH Connect to determine available configurations.

HOW TO USE COIL GROUPS

WITHIN A VALVE PAGE

One of Parker's strengths is the modularity, adaptability and flexibility of our products. When you select a solenoid valve, the coils displayed in the table have been chosen as they will fulfill the majority of application requirements.

Valve Ref.	Housing Ref.	Coil Ref.
121K3206	2995	481865
121K3206	4270	481000
121K3206	4270	486265

However, in some specific cases, you will need special features that will lead you to choose another coil.

Groups have been created in order to facilitate the selection of a compatible coil with the chosen valve.

Coil Group
2.0
2.0
2.0

Example:

The valve 121K3206 is proposed with the coil 481865 but you can also choose any coil from the group 2.0.

2 WAY VALVES

2/2

VALVES FOR DRY OR LUBRICATED AIR, NEUTRAL GASES AND LIQUIDS
DIRECT OPERATED

BRASS
PIPE MOUNTING
NORMALLY CLOSED



Port size	Orifice Ø	Flow factors	Operating Pressure Differential	Fluid Temp.	Seat Seal	Parker LUCIFER® Valves			Power		Coil Group	Dwg. No.	
						Valve Ref.	Housing Ref.	Coil Ref.	AC W	DC W			
3/8"	4	7.5 0.45	0 10	-4 -10	100 FKM	121K3206	2995	481865	8	9	2.0	3551	
	4	7.5 0.45	0 10	-4 -10	120 FKM	121K3206	4270	481000	8	8	2.0	3551	
	4	7.5 0.45	0 10	-10 -10	120 FKM	121K3206	4270	486265	14	14	2.0	3551	
	5	11 0.66	0 7	2 -10	100 FKM	121K3106	2995	481865	8	9	2.0	3551	
	5	11 0.66	0 7	2.8 -10	120 FKM	121K3106	4270	481000	8	8	2.0	3551	
	5	11 0.66	0 7	5 -10	120 FKM	121K3106	4270	486265	14	14	2.0	3551	
1/2"	6	12 0.72	0 5	1.1 -10	100 FKM	121K3306	2995	481865	8	8	2.0/14.2	3551	
	6	12 0.72	0 5	1.5 -10	120 FKM	121K3306	4270	481000	8	8	2.0/14.2	3551	
	6	12 0.72	0 5	3 -10	120 FKM	121K3306	4270	486265	14	14	2.0/14.2	3551	
	8.5	25 1.5	1600 0	1.1 0.5	-10	100 FKM	E121K46	2995	481865	8	9	2.0	3427
	8.5	25 1.5	1600 0	2.2 0.5	-10	120 FKM	E121K46	4270	481000	8	8	2.0	3427
	8.5	25 1.5	1600 0	4 1.2	-10	120 FKM	E121K46	4270	486265	14	14	2.0	3427
1/2"	11	36 2.16	2500 0	0.7 0.3	-10	100 FKM	E121K45	2995	481865	8	9	2.0	3427
	11	36 2.16	2500 0	1.2 0.35	-10	120 FKM	E121K45	4270	481000	8	8	2.0	3427
	11	36 2.16	2500 0	2.5 0.7	-10	120 FKM	E121K45	4270	486265	14	14	2.0	3427

Notes:
 1. Valve compatible with water up to 40°C.
 2. With manual override.

Parker

36

It is also possible to choose the coil first and then select the valve using coil groups.

HOW TO USE COIL GROUPS

WITHIN A COIL PAGE

The coil section is at the end of the catalogue and displays the specifications of each coil, along with the reference number, class of insulation, ambient temperature, electrical power and weight.

2.0 / 2.1

Example: the valve 121K3206 is proposed with coil 481865 but is also compatible with the 2.0 coil group. This means the coil 482725 is also compatible with the chosen valve as it is within this group.

When referring to the coil section you will find the coil group for each coil. This allows you to discover which other coils are compatible with the valve you have chosen.

COILS



COIL GROUP

2.0/2.1

COILS FOR
DIN PLUG CONNECTION

COILS 32 mm

These coils can be mounted with every Parker solenoid valves corresponding to the specified Coil Group. See column "Coil Group" within valve pages.

This is an encapsulated assembly comprising a coil, integral magnetic iron path and snap-on plug connection.

The synthetic material encapsulation provides an effective compact housing, offering full protection against dust, oil, water, etc.

Ease of mounting in confined space - offers shock and corrosion protection - simplifies conversion of existing equipment to other requirements, etc.

Coils conform to the IEC/CENELEC safety standards and complies with European low-voltage directive.



Specification	Standard	Double frequency					
Ref. (without DIN plug)	481865	483510					
Ref. (with DIN plug)	482725	482635					
Coil Group	2.0 / 2.1						
Degree of protection	IP65 according to IEC / EN 60529 standards (with DIN plug).						
Class of insulation	F 155°C						
Electrical connection	The coil is connected with a 2 P + E plug according to EN 175301-803 type A						
Ambient temperature	-40°C to +50°C The application is limited also by the temperature range of the valve.						
Electrical power	DC Pn (hot)	9 W					
	P (cold) 20°C	12 W					
	AC Pn (holding)	8 W					
	Attraction cold	26 VA (9 W) 32 VA (10 W)					
Weight	130 g (without plug)						
Voltages "Un"	VAC/Hz	Code	VDC	Code	VAC/Hz	Code	
	-10% to +10% of the Un	24/50 48/50 110/50 220-230/50	A2 A4 A5 3D	24 48 110	C2 C4 C5	24/50, 24/60 48/50, 48/60 110-115/50, 120/60 220-240/50, 240/60	P0 S4 S5 S6

To Order a Coil choose Coil Ref + Voltage Code, example: 481865 for 24 VDC = **481865C2**
More voltage possibilities can be found in the table of voltage codes at the end of the coil section.

These coils must be used with suitable housings, see example below:

The coil assembly kit **Ref. 2995** corresponds to the "housing"

It is composed of a nameplate giving details of the valve type, a round washer and a nut to ensure the fixing between 32 mm coil and the valve.

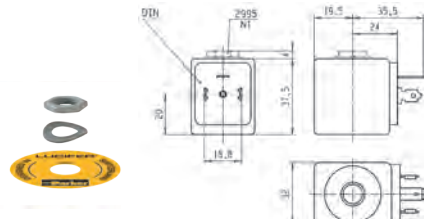

446

NOTES

KOVANZ.CZ



VALVES FOR DRY OR LUBRICATED AIR, NEUTRAL GASES AND LIQUIDS



2/2

Actuation	Body	Function	Port Size	Orifice (mm)	Flow Factor Kv(l/min)	MOPD (bar)	Max Fluid Temp. (°C)	Page Parker Valves		
Direct Operated	Brass/Pipe Mounting	Normally Closed	1/8"	1.5 to 3	4.5	70	130	22		
			1/4"	1.2 to 5	11	100	130	22 and 24		
			3/8"	4 to 6	12	10	120	26		
			1/2"	8.5 to 11	36	4	120	26		
			1/8"	2.5	3.5	30	140	28		
		Normally Open	1/4"	1.5 to 4.5	7.8	40	140	28		
			Control by Electric Impulse	1/4"	3 to 5	11	20	100	28	
				5 mm	1.5 to 3	4.5	100	130	30	
			Brass/Sub-base Mounting	Normally Open	5 mm	1.5	1.5	20	120	32
				Magnalift	Brass/Pipe Mounting	Normally Closed	3/8"	15	65	20
1/2"	15	65	20				140	34		
3/4"	15	80	20				140	36		
1"	15 to 25	170	20				120	38		
Normally Open	1/4"	8 to 12	36				40	120	40	
	3/8"	11 to 12	50			40	120	42		
	1/2"	11 to 15	60			40	120	44		
	3/4"	15 to 20	135			40	120	46		
	1"	18 to 25	185			16	120	48		
Pilot Operated	Brass/Pipe Mounting	Normally Closed	1 1/4"			28	270	16	120	48
			1 1/2"	40	425	16	120	50		
			2"	40	540	16	120	50		
			Normally Open	1/4"	8	36	40	140	52	
				3/8"	11	50	40	140	52	
				1/2"	15	60	40	140	52	
				3/4"	15 to 20	135	40	120	54	
				1"	25	180	16	120	54	
			Control by Electric Impulse	1 1/4"	28	270	16	120	54	
				1 1/2"	40	420	12	100	54	
		2"		40	540	12	100	54		
		1/4"		12	32	12	100	56		
		3/8"		12	45	12	100	56		
		1/2"		12	50	12	100	56		
		3/4"		18	100	12	100	56		
		1"		18	110	12	100	56		
		Brass/Sub-base Mounting		Normally Closed	14 mm	14	45	40	140	58
				Normally Open	14 mm	14	46	40	120	58

2/2

VALVES FOR DRY OR LUBRICATED AIR, NEUTRAL GASES AND LIQUIDS DIRECT OPERATED

BRASS

PIPE MOUNTING

NORMALLY CLOSED

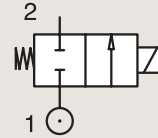

Port size (BSP)	Orifice Ø mm	Flow factors			Operating Pressure Differential Max(MOPD)			Fluid Temp.		Seat Seal	Valve Ref.	Housing Ref.	Coil Ref.	Power		Coil Group	Dwg. No.
		Kv l/min	KV m³/h	Qn m³/h	Min bar	AC bar	DC bar	Min °C	Max °C					AC W	DC W		
1/8"	1.5	0.9	0.05	70	0	20	12	-10	75	FKM	121M14	8993	481180	4	5	1.1	3382
	1.5	0.9	0.05	70	0	20	4	-10	75	FKM	121M14	8993	488980	2	2.5	1.1	3382
	1.5	1.5	0.09	80	0	60	25	-30	75	PCTFE	E121K14	2995	481865	8	9	2.0	3510
	1.5	1.5	0.09	80	0	70	30	-30	75	PCTFE	E121K14	4270	481000	8	8	2.0	3510
	1.5	1.5	0.09	80	0	70	55	-30	75	PCTFE	E121K14	4270	486265	14	14	2.0	3510
	2	2	0.12	125	0	10	7	-10	75	FKM	121M13	8993	481180	4	5	1.1	3382
	2	2	0.12	125	0	10	2.5	-10	75	FKM	121M13	8993	488980	2	2.5	1.1	3382
	2.5	2.8	0.17	-	0	10	10	-10	75	FKM	121Z03	2995	481865	8	9	2.0	7863
	2.5	3.5	0.21	220	0	28	10	-30	100	Ruby	E121K23	2995	481865	8	9	2.0	3510
	2.5	3.5	0.21	220	0	34	12	-30	130	Ruby	E121K23	4270	481000	8	8	2.0	3510
	2.5	3.5	0.21	220	0	50	22	-30	120	Ruby	E121K23	4270	486265	14	14	2.0	3510
	3	4.5	0.27	320	0	10	7	-10	100	FKM	121K1302	2995	481865	8	9	2.0	3510
3	4.5	0.27	320	0	10	8	-10	120	FKM	121K1302	4270	481000	8	8	2.0	3510	
3	4.5	0.27	320	0	10	10	-10	120	FKM	121K1302	4270	486265	14	14	2.0	3510	
1/4"	1.2	0.85	0.05	50	0	80	36	-30	100	Ruby	E121K65	2995	481865	8	9	2.0	3510
	1.2	0.85	0.05	50	0	100	43	-30	130	Ruby	E121K65	4270	481000	8	8	2.0	3510
	1.2	0.85	0.05	50	0	100	75	-30	120	Ruby	E121K65	4270	486265	14	14	2.0	3510
	1.5	1.5	0.09	80	0	-	8	-20	75	PUR	121K0497 ₁	2995	482740	-	1.6	6.0/8.0	8274
	1.5	1.5	0.09	80	0	-	8	-20	65	PUR	121K0497 ₁	2995	496125	-	1.6	6.0/8.0	8274
	1.5	1.5	0.09	80	0	10	10	-20	75	PUR	121K0497 ₁	-	495900	2.5	2	6.0/8.0	8274
	1.5	1.5	0.09	80	0	-	10	-20	75	PUR	121K0497 ₁	-	495910	-	0.3-1.2	6.0/8.0	8274
	1.5	1.5	0.09	80	0	60	25	-30	75	PCTFE	E121K04	2995	481865	8	9	2.0	3510
	1.5	1.5	0.09	80	0	70	30	-30	75	PCTFE	E121K04	4270	481000	8	8	2.0	3510
	1.5	1.5	0.09	80	0	70	55	-30	75	PCTFE	E121K04	4270	486265	14	14	2.0	3510
	1.5	1.5	0.09	80	0	20	20	-10	100	FKM	E121K0402	2995	481865	8	9	2.0/3.0	3510
	1.5	1.5	0.09	80	0	20	20	-10	120	FKM	E121K0402	4270	481000	8	8	2.0/3.0	3510
	1.5	1.5	0.09	80	0	60	25	-30	100	Ruby	E121K67	2995	481865	8	9	2.0	3510
	1.5	1.5	0.09	80	0	75	30	-30	130	Ruby	E121K67	4270	481000	8	8	2.0	3510
	1.5	1.5	0.09	80	0	100	55	-30	120	Ruby	E121K67	4270	486265	14	14	2.0	3510
	2.5	3.5	0.21	220	0	14	7	-10	100	FKM	121K0706	2995	481865	8	9	2.0	3510
	2.5	3.5	0.21	220	0	14	9	-10	120	FKM	121K0706	4270	481000	8	8	2.0	3510
	2.5	3.5	0.21	220	0	14	14	-10	120	FKM	121K0706	4270	486265	14	14	2.0	3510
	2.5	3.5	0.21	220	0	28	10	-30	75	PCTFE	E121K07	2995	481865	8	9	2.0	3510
	2.5	3.5	0.21	220	0	34	12	-30	75	PCTFE	E121K07	4270	481000	8	8	2.0	3510
2.5	3.5	0.21	220	0	50	22	-30	75	PCTFE	E121K07	4270	486265	14	14	2.0	3510	

Notes:

1.If fluid is water, media temperature shall not exceed 40°C



For this page	Port size	Orifice (mm)	Kv (l/min)	MOPD (bar)	Fluid Temp (°C)
From	1/8"	1.2	0.9	2.5	-30
To	1/4"	3	4.5	100	130

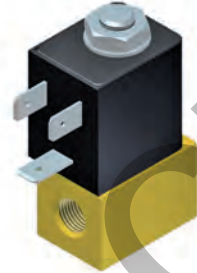
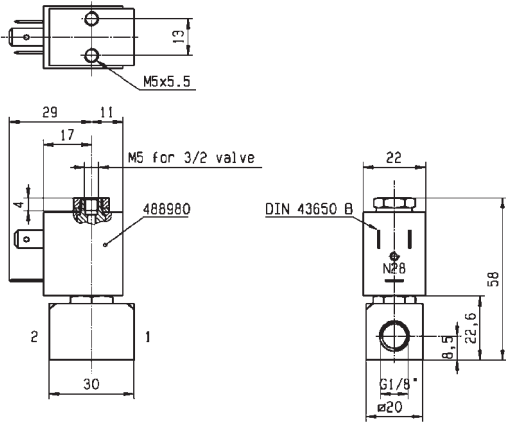

Drawing 3382

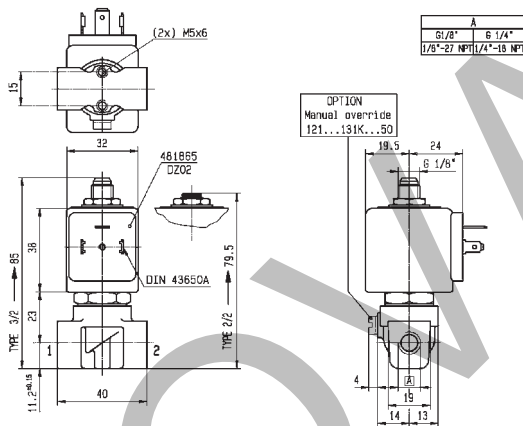

Drawing 3510

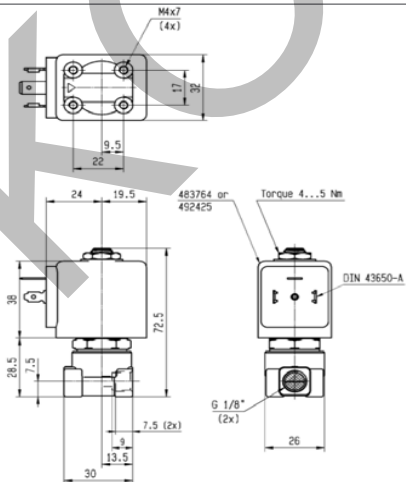

Drawing 7863

2/2

VALVES FOR DRY OR LUBRICATED AIR, NEUTRAL GASES AND LIQUIDS
DIRECT OPERATED

BRASS

PIPE MOUNTING

NORMALLY CLOSED

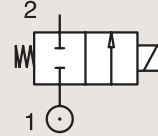

Port size (BSP)	Orifice Ø mm	Flow factors			Operating Pressure Differential Max(MOPD)			Fluid Temp.		Seat Seal	Valve Ref.	Housing Ref.	Coil Ref.	Power		Coil Group	Dwg. No.
		Kv l/min	KV m³/h	Qn m³/h	Min bar	AC bar	DC bar	Min °C	Max °C					AC W	DC W		
1/4"	2.5	3.5	0.21	220	0	28	10	-30	100	Ruby	E121K63	2995	481865	8	9	2.0	3510
	2.5	3.5	0.21	220	0	34	12	-30	130	Ruby	E121K63	4270	481000	8	8	2.0	3510
	2.5	3.5	0.21	220	0	50	22	-30	120	Ruby	E121K63	4270	486265	14	14	2.0	3510
	3	3.5	0.21	250	0	-	2	-20	75	PUR	121K0397 ₁	2995	482740	-	1.6	6.0/8.0	8274
	3	3.5	0.21	250	0	-	2	-20	65	PUR	121K0397 ₁	2995	496125	-	1.6	6.0/8.0	8274
	3	3.5	0.21	250	0	4.5	4	-20	75	PUR	121K0397 ₁	-	495900	2.5	2	6.0/8.0	8274
	3	3.5	0.21	250	0	-	4.5	-20	75	PUR	121K0397 ₁	-	495910	-	0.3-1.2	6.0/8.0	8274
	3	4.5	0.27	320	0	20	7	-30	75	PCTFE	E121K03	2995	481865	8	9	2.0/3.0	3510
	3	4.5	0.27	320	0	25	8.5	-30	75	PCTFE	E121K03	4270	481000	8	8	2.0/3.0	3510
	3	4.5	0.27	320	0	36	15	-30	75	PCTFE	E121K03	4270	486265	14	14	2.0/3.0	3510
	3	4.5	0.27	320	0	10	7	-10	100	FKM	E121K0302	2995	481865	8	9	2.0	3510
	3	4.5	0.27	320	0	10	8.5	-10	120	FKM	E121K0302	4270	481000	8	8	2.0	3510
	3	4.5	0.27	320	0	10	7	-10	100	FKM	E121K0302	4270	486265	14	14	2.0	3510
	3	4.5	0.27	320	0	10	7	-10	100	FKM	E121K0352 ₂	2995	481865	8	9	2.0	3510
	3	4.5	0.27	320	0	10	8.5	-10	120	FKM	E121K0352 ₂	4270	481000	8	8	2.0	3510
	3	4.5	0.27	320	0	10	10	-10	120	FKM	E121K0352 ₂	4270	486265	14	14	2.0	3510
	3	4.5	0.27	320	0	20	7	-30	100	Ruby	E121K64	2995	481865	8	9	2.0	3510
	3	4.5	0.27	320	0	25	8.5	-30	130	Ruby	E121K64	4270	481000	8	8	2.0	3510
	3	4.5	0.27	320	0	36	15	-30	120	Ruby	E121K64	4270	486265	14	14	2.0	3510
	4	7.5	0.45	480	0	10	4	-10	100	FKM	121K02	2995	481865	8	9	2.0	3510
	4	7.5	0.45	480	0	10	5	-10	120	FKM	121K02	4270	481000	8	8	2.0	3510
	4	7.5	0.45	480	0	10	10	-10	120	FKM	121K02	4270	486265	14	14	2.0	3510
	4	7.5	0.45	480	0	10	4	-10	100	FKM	121K0250 ₂	2995	481865	8	9	2.0	3510
	4	7.5	0.45	480	0	10	5	-10	120	FKM	121K0250 ₂	4270	481000	8	8	2.0	3510
	4	7.5	0.45	480	0	10	10	-10	120	FKM	121K0250 ₂	4270	486265	14	14	2.0	3510
	5	11	0.66	750	0	7	2	-10	100	FKM	121K01	2995	481865	8	9	2.0/14.2	3510
	5	11	0.66	750	0	7	2.8	-10	120	FKM	121K01	4270	481000	8	8	2.0/14.2	3510
	5	11	0.66	750	0	7	5	-10	120	FKM	121K01	4270	486265	14	14	2.0/14.2	3510
	5	11	0.66	750	0	7	2	-10	100	FKM	121K0150 ₂	2995	481865	8	9	2.0	3510
	5	11	0.66	750	0	7	2.8	-10	120	FKM	121K0150 ₂	4270	481000	8	8	2.0	3510
5	11	0.66	750	0	7	5	-10	120	FKM	121K0150 ₂	4270	486265	14	14	2.0	3510	
6.5	-	-	1400	0	0.5	0.5	-10	100	FKM	121K0601	2995	481865	8	9	2.0	3510	
6.5	-	-	1400	0	0.5	0.5	-10	120	FKM	121K0601	4270	481000	8	8	2.0	3510	

Notes:

- 1.If fluid is water, media temperature shall not exceed 40°C
- 2.With manual override



For this page	Port size	Orifice (mm)	Kv (l/min)	MOPD (bar)	Fluid Temp (°C)
From	1/4"	2.5	3.5	2	-30
To	1/4"	5	11	50	130

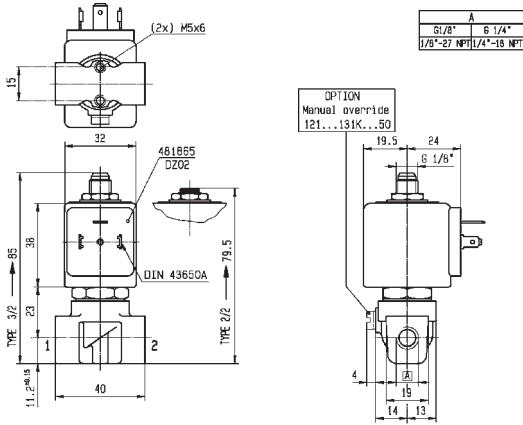

Drawing 3510

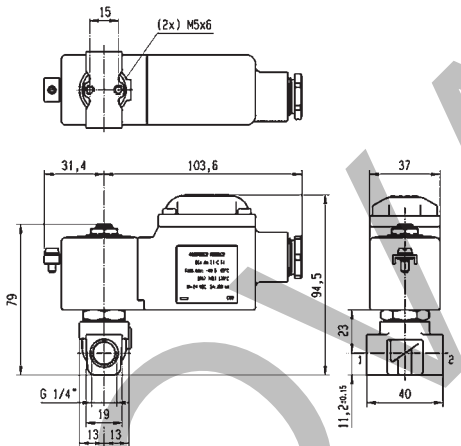

Drawing 8274

2/2

VALVES FOR DRY OR LUBRICATED AIR, NEUTRAL
GASES AND LIQUIDS
DIRECT OPERATED

BRASS

PIPE MOUNTING

NORMALLY CLOSED

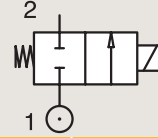

Port size (BSP)	Orifice Ø mm	Flow factors			Operating Pressure Differential Max(MOPD)			Fluid Temp.		Seat Seal	Valve Ref.	Housing Ref.	Coil Ref.	Power		Coil Group	Dwg. No.
		Kv l/min	KV m³/h	Qn m³/h	Min bar	AC bar	DC bar	Min °C	Max °C					AC W	DC W		
3/8"	4	7.5	0.45	480	0	10	4	-10	100	FKM	121K3206	2995	481865	8	9	2.0	3551
	4	7.5	0.45	480	0	10	5	-10	120	FKM	121K3206	4270	481000	8	8	2.0	3551
	4	7.5	0.45	480	0	10	10	-10	120	FKM	121K3206	4270	486265	14	14	2.0	3551
	5	11	0.66	750	0	7	2	-10	100	FKM	121K3106	2995	481865	8	9	2.0	3551
	5	11	0.66	750	0	7	2.8	-10	120	FKM	121K3106	4270	481000	8	8	2.0	3551
	5	11	0.66	750	0	7	5	-10	120	FKM	121K3106	4270	486265	14	14	2.0	3551
	6	12	0.72	1100	0	5	1.1	-10	100	FKM	121K3306	2995	481865	8	9	2.0/14.2	3551
	6	12	0.72	1100	0	5	1.5	-10	120	FKM	121K3306	4270	481000	8	8	2.0/14.2	3551
	6	12	0.72	1100	0	5	3	-10	120	FKM	121K3306	4270	486265	14	14	2.0/14.2	3551
1/2"	8.5	25	1.5	1600	0	1.1	0.5	-10	100	FKM	E121K46	2995	481865	8	9	2.0	3427
	8.5	25	1.5	1600	0	2.2	0.5	-10	120	FKM	E121K46	4270	481000	8	8	2.0	3427
	8.5	25	1.5	1600	0	4	1.2	-10	120	FKM	E121K46	4270	486265	14	14	2.0	3427
	11	36	2.16	2500	0	0.7	0.3	-10	100	FKM	E121K45	2995	481865	8	9	2.0	3427
	11	36	2.16	2500	0	1.2	0.35	-10	120	FKM	E121K45	4270	481000	8	8	2.0	3427
	11	36	2.16	2500	0	2.5	0.7	-10	120	FKM	E121K45	4270	486265	14	14	2.0	3427



For this page	Port size	Orifice (mm)	Kv (l/min)	MOPD (bar)	Fluid Temp (°C)
From	3/8"	4	7.5	0.3	-10
To	1/2"	11	36	10	120

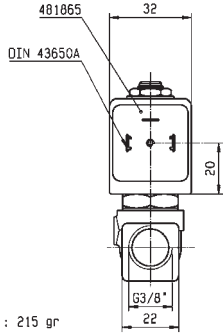
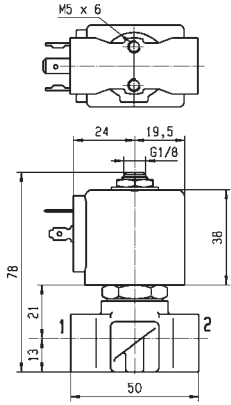

WEIGHT : 215 gr



Drawing 3551

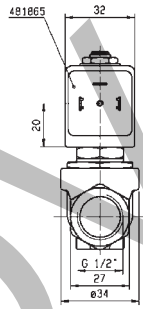
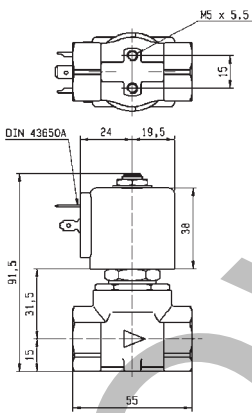

Drawing 3427

2/2

VALVES FOR DRY OR LUBRICATED AIR, NEUTRAL GASES AND LIQUIDS
DIRECT OPERATED

BRASS

PIPE MOUNTING

NORMALLY OPEN

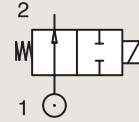

Port size	Orifice Ø	Flow factors			Operating Pressure Differential			Fluid Temp.		Seat Seal	Valve Ref.	Housing Ref.	Coil Ref.	Power		Coil Group	Dwg. No.
		Kv l/min	KV m³/h	Qn l/min	Min bar	Max(MOPD) AC bar	DC bar	Min °C	Max °C					AC W	DC W		
1/8"	2.5	3.5	0.21	-	0	30	-	-30	140	Ruby	122K9363	4270	481044	14	-	2.2	3510
	2.5	3.5	0.21	-	0	30	30	-30	140	Ruby	122K9363	4270	486265	14	14	2.2	3510
	1.5	1.5	0.09	80	0	30	30	-10	100	PCTFE	122K84	2995	481865	8	9	2.0	3510
1/4"	1.5	1.5	0.09	80	0	30	30	-10	100	PCTFE	122K84	4270	481000	8	8	2.0	3510
	1.5	1.5	0.09	80	0	30	30	-10	120	PCTFE	122K84	4270	486265	14	14	2.0	3510
	1.5	1.5	0.09	80	0	20	20	-10	100	FKM	122K8406	2995	481865	8	9	2.1	3510
	1.5	1.5	0.09	80	0	20	20	-10	120	FKM	122K8406	4270	481000	8	8	2.1	3510
	1.5	1.5	0.09	80	0	40	40	-30	100	Ruby	122K8408	2995	481865	8	9	2.0	3510
	1.5	1.5	0.09	80	0	40	40	-30	130	Ruby	122K8408	4270	481000	8	8	2.0	3510
	1.5	1.5	0.09	80	0	40	40	-30	130	Ruby	122K8408	4270	486265	14	14	2.0	3510
	2.5	3	0.18	180	0	12	12	-30	75	PCTFE	122K83	2995	481865	8	9	2.0	3510
	2.5	3	0.18	180	0	12	12	-30	75	PCTFE	122K83	4270	481000	8	8	2.0	3510
	2.5	3	0.18	180	0	12	12	-30	75	PCTFE	122K83	4270	486265	14	14	2.0	3510
	2.5	3	0.18	180	0	12	12	-10	100	FKM	122K8306	2995	481865	8	9	2.0	3510
	2.5	3	0.18	180	0	12	12	-10	120	FKM	122K8306	4270	481000	8	8	2.0	3510
	2.5	3	0.18	180	0	12	12	-10	120	FKM	122K8306	4270	486265	14	14	2.0	3510
	2.5	3.5	0.21	-	0	30	-	-30	140	Ruby	122K8363	4270	481044	14	-	2.2	3510
	2.5	3.5	0.21	-	0	30	30	-30	140	Ruby	122K8363	4270	486265	14	14	2.2	3510
4.5	7.8	0.47	-	0	4	4	-10	120	FKM	122K8606	2995	492425	14	14	-	3510	

Notes: 1. Valve compatible only with 492425 or 491514 coils

BRASS

PIPE MOUNTING

CONTROL BY ELECTRIC IMPULSE

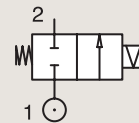

Port size	Orifice Ø	Flow factors			Operating Pressure Differential			Fluid Temp.		Seat Seal	Valve Ref.	Housing Ref.	Coil Ref.	Power		Coil Group	Dwg. No.
		Kv l/min	KV m³/h	Qn l/min	Min bar	Max(MOPD) AC bar	DC bar	Min °C	Max °C					AC W	DC W		
1/4"	3	4.5	0.27	320	0	20	-	-30	75	PCTFE	125K03	4269	484990	11	-	4.0	8296
	3	4.5	0.27	320	0	-	7	-30	75	PCTFE	125K03	4269	485400	-	13	4.0	8296
1/4"	5	11	0.66	750	0	5	-	-10	100	FKM	125K01	4269	484990	11	-	4.0	8296
	5	11	0.66	750	0	-	1.5	-10	100	FKM	125K01	4269	485400	-	13	4.0	8296



For this page	Port size	Orifice (mm)	Kv (l/min)	MOPD (bar)	Fluid Temp (°C)
From	1/8"	1.5	1.5	1.5	-30
To	1/4"	5	11	40	140

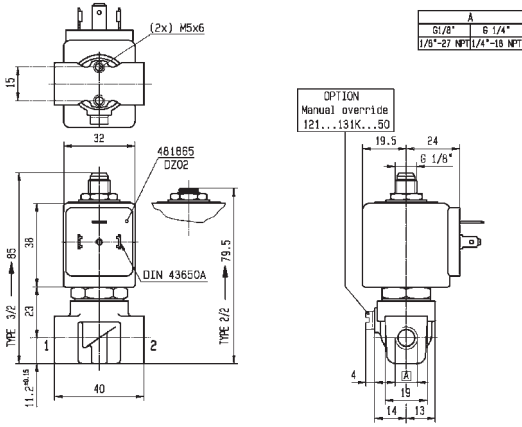

Drawing 3510

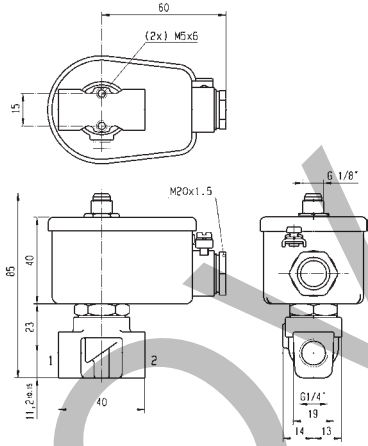

Drawing 8296

2/2

VALVES FOR DRY OR LUBRICATED AIR, NEUTRAL GASES AND LIQUIDS
DIRECT OPERATED

BRASS

SUB-BASE MOUNTING

NORMALLY CLOSED

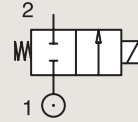

Port size	Orifice Ø mm	Flow factors			Operating Pressure Differential Max(MOPD)			Fluid Temp.		Seat Seal	Valve Ref.	Housing Ref.	Coil Ref.	Power		Coil Group	Dwg. No.
		Kv l/min	KV m³/h	Qn l/min	Min bar	AC bar	DC bar	Min °C	Max °C					AC W	DC W		
SB	1.5	1.5	0.09	80	0	20	-	-10	100	EPDM	121F4417	2995	483510	9	-	2.0	3509
	1.5	1.5	0.09	80	0	60	25	-30	100	Ruby	121F67	2995	481865	8	9	2.0	3509
	1.5	1.5	0.09	80	0	75	30	-30	130	Ruby	121F67	4270	481000	8	8	2.0	3509
	1.5	1.5	0.09	80	0	100	55	-30	120	Ruby	121F67	4270	486265	14	14	2.0	3509
	1.5	1.5	0.09	80	0	60	25	-30	75	PCTFE	E121F44	2995	481865	8	9	2.0	3509
	1.5	1.5	0.09	80	0	70	30	-30	75	PCTFE	E121F44	4270	481000	8	8	2.0	3509
	1.5	1.5	0.09	80	0	70	55	-30	75	PCTFE	E121F44	4270	486265	14	14	2.0	3509
	1.5	1.5	0.09	80	0	20	20	-10	100	FKM	E121F4406	2995	481865	8	9	2.0	3509
	1.5	1.5	0.09	80	0	20	20	-10	120	FKM	E121F4406	4270	481000	8	8	2.0	3509
	1.5	1.5	0.09	80	0	20	20	-10	120	FKM	E121F4406	4270	486265	14	14	2.0	3509
	2.5	3.5	0.21	220	0	28	10	-30	75	PCTFE	121F47	2995	481865	8	9	2.0	3509
	2.5	3.5	0.21	220	0	34	12	-30	75	PCTFE	121F47	4270	481000	8	8	2.0	3509
	2.5	3.5	0.21	220	0	50	22	-30	75	PCTFE	121F47	4270	486265	14	14	2.0	3509
	2.5	3.5	0.21	220	0	14	7	-10	100	FKM	121F4706	2995	481865	8	9	2.0	3509
	2.5	3.5	0.21	220	0	14	9	-10	120	FKM	121F4706	4270	481000	8	8	2.0	3509
	2.5	3.5	0.21	220	0	14	14	-10	120	FKM	121F4706	4270	486265	14	14	2.0	3509
	2.5	3.5	0.21	220	0	28	10	-30	100	Ruby	121F63	2995	481865	8	9	2.0	3509
	2.5	3.5	0.21	220	0	34	12	-30	130	Ruby	121F63	4270	481000	8	8	2.0	3509
	2.5	3.5	0.21	220	0	50	22	-30	120	Ruby	121F63	4270	486265	14	14	2.0	3509
	3	4.5	0.27	320	0	20	7	-30	100	Ruby	121F64	2995	481865	8	9	2.0	3509
	3	4.5	0.27	320	0	25	8.5	-30	130	Ruby	121F64	4270	481000	8	8	2.0	3509
	3	4.5	0.27	320	0	36	15	-30	120	Ruby	121F64	4270	486265	14	14	2.0	3509
	3	4.5	0.27	320	0	20	7	-30	75	PCTFE	E121F43	2995	481865	8	9	2.0	3509
	3	4.5	0.27	320	0	25	8.5	-30	75	PCTFE	E121F43	4270	481000	8	8	2.0	3509
	3	4.5	0.27	320	0	36	15	-30	75	PCTFE	E121F43	4270	486265	14	14	2.0	3509
	3	4.5	0.27	320	0	10	7	-10	100	FKM	E121F4302	2995	481865	8	9	2.0/3.0	3509
	3	4.5	0.27	320	0	10	8.5	-10	120	FKM	E121F4302	4270	481000	8	8	2.0/3.0	3509
	3	4.5	0.27	320	0	10	10	-10	120	FKM	E121F4302	4270	486265	14	14	2.0/3.0	3509



For this page	Port size	Orifice (mm)	Kv (l/min)	MOPD (bar)	Fluid Temp (°C)
From	5 mm	1.5	1.5	7	-30
To	5 mm	3	4.5	100	130

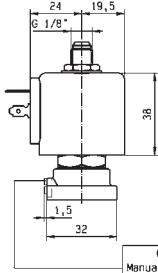
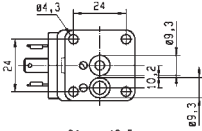

OPTION
Manual override
121...131F...50

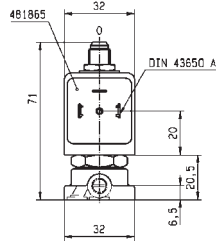

Drawing 3509

KOVAR

2/2

VALVES FOR DRY OR LUBRICATED AIR, NEUTRAL GASES AND LIQUIDS
DIRECT OPERATED

BRASS

SUB-BASE MOUNTING

NORMALLY OPEN

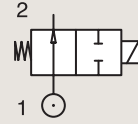

Port size	Orifice Ø			Flow factors			Operating Pressure Differential			Fluid Temp.		Seat Seal	Valve Ref.	Housing Ref.	Coil Ref.	Power		Coil Group	Dwg. No.
	mm	Kv l/min	KV m³/h	Qn l/min	Min bar	Max(MOPD) AC bar	DC bar	Min °C	Max °C	AC W	DC W								
SB	1.5	1.5	0.09	80	0	20	20	-10	100	FKM	122F44	2995	481865	8	9	2.1	3509		
	1.5	1.5	0.09	80	0	20	20	-10	120	FKM	122F44	4270	481000	8	8	2.1	3509		



For this page	Port size	Orifice (mm)	Kv (l/min)	MOPD (bar)	Fluid Temp (°C)
From	5 mm	1.5	1.5	20	-10
To	5 mm	1.5	1.5	20	120

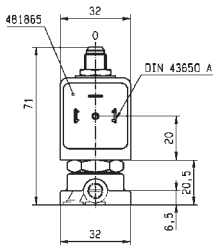
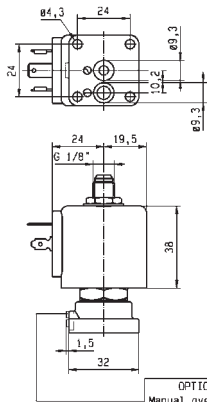

OPTION
Manual override
121...131F...50

Drawing 3509

KOLVAR

2/2

VALVES FOR DRY OR LUBRICATED AIR, NEUTRAL GASES AND LIQUIDS
MAGNALIFT

BRASS

PIPE MOUNTING

NORMALLY CLOSED

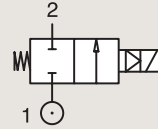

Port size	Orifice Ø	Flow factors			Operating Pressure Differential			Fluid Temp.		Seat Seal	Valve Ref.	Housing Ref.	Coil Ref.	Power		Coil Group	Dwg. No.
		Kv l/min	KV m³/h	Qn l/min	Min bar	Max(MOPD) AC bar	DC bar	Min °C	Max °C					AC W	DC W		
3/8"	15	65	3.9	4500	0	16	-	-10	100	NBR	221G13	2995	481865	8	-	2.0	3732
	15	65	3.9	4500	0	16	-	-10	100	NBR	221G13	4270	481000	8	-	2.0	3732
	15	65	3.9	4500	0	16	16	-10	100	NBR	221G13	4270	486265	14	14	2.0	3732
	15	65	3.9	4500	0	16	-	0	100	FKM	221G23 ₁	2995	481865	8	-	2.0	3732
	15	65	3.9	4500	0	16	-	0	120	FKM	221G23 ₁	4270	481000	8	-	2.0	3732
	15	65	3.9	4500	0	20	7	0	140	FKM	221G23 ₁	4270	486265	14	14	2.0	3732
	15	65	3.9	4500	0	-	10	-10	100	FKM	221G2330 ₁₂	2995	481865	-	9	2.1	3732
	15	65	3.9	4500	0	10	10	-10	65	FKM	221G2330 ₁₂	-	492070	9	8	2.1	3732
	15	65	3.9	4500	0	10	10	-10	75	FKM	221G2330 ₁₂	-	492190	11	9	2.1	3732
1/2"	15	65	3.9	4500	0	16	-	-10	100	NBR	221G15	2995	481865	8	-	2.0	3732
	15	65	3.9	4500	0	16	-	-10	100	NBR	221G15	4270	481000	8	-	2.0	3732
	15	65	3.9	4500	0	16	7	-10	100	NBR	221G15	4270	486265	14	14	2.0	3732
	15	65	3.9	4500	0	-	10	-10	100	NBR	221G1530 ₂₃	2995	481865	-	9	2.1	3732
	15	65	3.9	4500	0	10	10	-10	65	NBR	221G1530 ₂₃	-	492070	9	8	2.1	3732
	15	65	3.9	4500	0	10	10	-10	75	NBR	221G1530 ₂₃	-	492190	11	9	2.1	3732
	15	65	3.9	4500	0	16	-	0	100	FKM	221G25 ₁	2995	481865	8	-	2.0	3732
	15	65	3.9	4500	0	16	-	0	120	FKM	221G25 ₁	4270	481000	8	-	2.0	3732
	15	65	3.9	4500	0	20	7	0	140	FKM	221G25 ₁	4270	486265	14	14	2.0	3732
	15	65	3.9	4500	0	-	10	-10	100	FKM	221G2530 ₁₂	2995	481865	-	9	2.1	3732
	15	65	3.9	4500	0	10	10	-10	65	FKM	221G2530 ₁₂	-	492070	9	8	2.1	3732
	15	65	3.9	4500	0	10	10	-10	75	FKM	221G2530 ₁₂	-	492190	11	9	2.1	3732

Notes:

1. Valve only compatible with hydraulic oil and air/neutral gases
2. Valves with model number ending in 30 or 31 are mainly equipped with electrical parts for explosion proof applications or with standard DC coils.
3. With 4 position selector for controlled closure rate.
4. Pilot seat in FKM



For this page	Port size	Orifice (mm)	Kv (l/min)	MOPD (bar)	Fluid Temp (°C)
From	3/8"	15	65	7	-10
To	1/2"	15	65	20	140

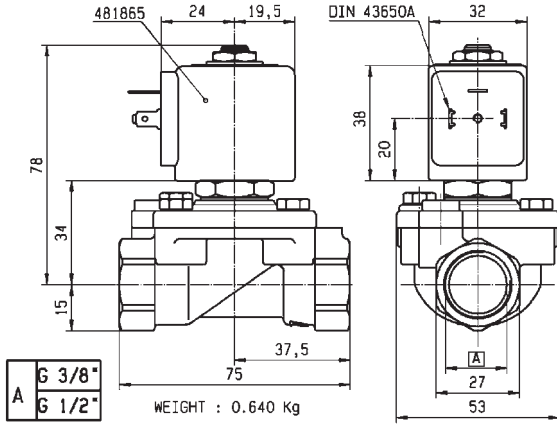

Drawing 3732

KONVANTUM

2/2

VALVES FOR DRY OR LUBRICATED AIR, NEUTRAL GASES AND LIQUIDS
MAGNALIFT

BRASS

PIPE MOUNTING

NORMALLY CLOSED

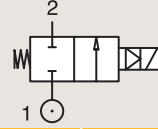

Port size	Orifice Ø	Flow factors			Operating Pressure Differential			Fluid Temp.		Seat Seal	Valve Ref.	Housing Ref.	Coil Ref.	Power		Coil Group	Dwg. No.
		Kv l/min	KV m³/h	Qn l/min	Min bar	Max(MOPD) AC bar	DC bar	Min °C	Max °C					AC W	DC W		
3/4"	15	80	4.8	6000	0	16	-	-10	100	NBR	221G16 ₄	2995	481865	8	-	2.0	3444
	15	80	4.8	6000	0	16	-	-10	100	NBR	221G16 ₄	4270	481000	8	-	2.0	3444
	15	80	4.8	6000	0	7	7	-10	100	NBR	221G16 ₄	4270	486265	14	14	2.0	3444
	15	80	4.8	6000	0	16	-	-10	100	NBR	221G1610 ₃	2995	481865	8	-	2.0	3444
	15	80	4.8	6000	0	16	-	-10	100	NBR	221G1610 ₃	4270	481000	8	-	2.0	3444
	15	80	4.8	6000	0	16	7	-10	100	NBR	221G1610 ₃	4270	486265	14	14	2.0	3444
	15	80	4.8	6000	0	10	10	-10	100	NBR	221G1630 ₂₄	2995	481865	8	9	2.1	3444
	15	80	4.8	6000	0	10	10	-25	40	NBR	221G1630 ₂₄	-	492070	9	8	2.1	3444
	15	80	4.8	6000	0	10	10	-25	40	NBR	221G1630 ₂₄	-	492190	11	9	2.1	3444
	15	80	4.8	6000	0	10	10	-10	100	NBR	221G1631 ₂₃₄	2995	481865	8	9	2.1	3444
	15	80	4.8	6000	0	10	10	-25	40	NBR	221G1631 ₂₃₄	-	492070	9	8	2.1	3444
	15	80	4.8	6000	0	10	10	-25	40	NBR	221G1631 ₂₃₄	-	492190	11	9	2.1	3444
	15	80	4.8	6000	0	16	-	0	100	FKM	221G26 ₁	2995	481865	8	-	2.0	3444
	15	80	4.8	6000	0	16	-	0	120	FKM	221G26 ₁	4270	481000	8	-	2.0	3444
	15	80	4.8	6000	0	20	7	0	140	FKM	221G26 ₁	4270	486265	14	14	2.0	3444
	15	80	4.8	6000	0	-	10	-10	100	FKM	221G2630 ₁₂	2995	481865	-	9	2.1	3444
	15	80	4.8	6000	0	10	10	-25	40	FKM	221G2630 ₁₂	-	492070	9	8	2.1	3444
	15	80	4.8	6000	0	10	10	-25	40	FKM	221G2630 ₁₂	-	492190	11	9	2.1	3444

Notes:

1. Valve only compatible with hydraulic oil and air/neutral gases
2. Valves with model number ending in 30 or 31 are mainly equipped with electrical parts for explosion proof applications or with standard DC coils.
3. With 4 position selector for controlled closure rate.
4. Pilot seat in FKM



For this page	Port size	Orifice (mm)	Kv (l/min)	MOPD (bar)	Fluid Temp (°C)
From	3/4"	15	80	7	-25
To	3/4"	15	80	20	140

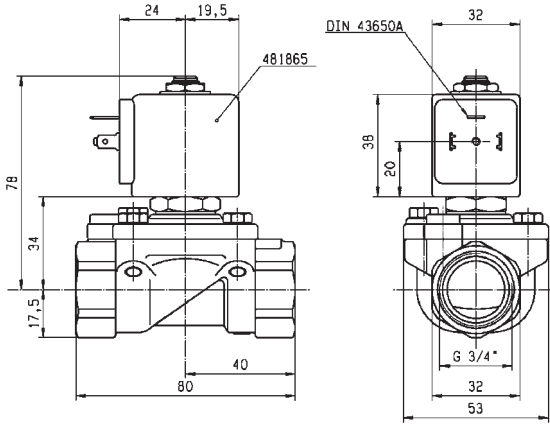

Drawing 3444

KOVLAV

2/2

VALVES FOR DRY OR LUBRICATED AIR, NEUTRAL GASES AND LIQUIDS MAGNALIFT

BRASS

PIPE MOUNTING

NORMALLY CLOSED

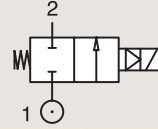

Port size	Orifice Ø	Flow factors			Operating Pressure Differential			Fluid Temp.		Seat Seal	Valve Ref.	Housing Ref.	Coil Ref.	Power		Coil Group	Dwg. No.
		Kv l/min	KV m³/h	Qn l/min	Min bar	Max(MOPD) AC bar	DC bar	Min °C	Max °C					AC W	DC W		
1"	15	80	4.8	6000	0	16	-	-10	100	NBR	221G17	2995	481865	8	-	2.0	3445
	15	80	4.8	6000	0	16	-	-10	100	NBR	221G17	4270	481000	8	-	2.0	3445
	15	80	4.8	6000	0	16	7	-10	100	NBR	221G17	4270	486265	14	14	2.0	3445
	15	80	4.8	6000	0	16	-	-10	100	NBR	221G1710 ₃	2995	481865	8	-	2.0	3445
	15	80	4.8	6000	0	16	-	-10	100	NBR	221G1710 ₃	4270	481000	8	-	2.0	3445
	15	80	4.8	6000	0	16	7	-10	100	NBR	221G1710 ₃	4270	486265	14	14	2.0	3445
	15	80	4.8	6000	0	-	10	-10	100	NBR	221G1730 ₂₄	2995	481865	-	9	2.1	3445
	15	80	4.8	6000	0	10	10	-10	65	NBR	221G1730 ₂₄	-	492070	9	8	2.1	3445
	15	80	4.8	6000	0	10	10	-10	75	NBR	221G1730 ₂₄	-	492190	11	9	2.1	3445
	15	80	4.8	6000	0	16	-	0	100	FKM	221G27 ₁	2995	481865	8	-	2.0	3445
	15	80	4.8	6000	0	16	-	0	120	FKM	221G27 ₁	4270	481000	8	-	2.0	3445
	15	80	4.8	6000	0	20	7	0	120	FKM	221G27 ₁	4270	486265	14	14	2.0	3445
	15	80	4.8	6000	0	-	10	0	100	FKM	221G2730 ₁₂	2995	481865	-	9	2.1	3445
	15	80	4.8	6000	0	10	10	-10	65	FKM	221G2730 ₁₂	-	492070	9	8	2.1	3445
	15	80	4.8	6000	0	10	10	-10	75	FKM	221G2730 ₁₂	-	492190	11	9	2.1	3445
	25	170	10.2	14000	0	16	-	-10	100	NBR	221G21	2995	481865	8	-	2.0	3448
	25	170	10.2	14000	0	16	-	-10	100	NBR	221G21	4270	481000	8	-	2.0	3448
	25	170	10.2	14000	0	16	6	-10	100	NBR	221G21	4270	486265	14	14	2.0	3448
	25	160	9.6	14000	0	16	-	0	100	FKM	221G2106 ₁	2995	481865	8	-	2.0	3448
	25	160	9.6	14000	0	16	-	0	120	FKM	221G2106 ₁	4270	481000	8	-	2.0	3448
	25	160	9.6	14000	0	16	6	0	120	FKM	221G2106 ₁	4270	486265	14	14	2.0	3448
	25	160	9.6	14000	0	16	-	-10	100	NBR	221G2110 ₃	2995	481865	8	-	2.0	3448
	25	160	9.6	14000	0	16	-	-10	100	NBR	221G2110 ₃	4270	481000	8	-	2.0	3448
	25	160	9.6	14000	0	16	6	-10	100	NBR	221G2110 ₃	4270	486265	14	14	2.0	3448
	25	170	10.2	14000	0	-	10	-10	40	NBR	221G2130 ₁₂₄	2995	481865	-	9	2.1	3448
	25	170	10.2	14000	0	10	10	-10	40	NBR	221G2130 ₁₂₄	-	492070	9	8	2.1	3448
	25	170	10.2	14000	0	10	10	-10	40	NBR	221G2130 ₁₂₄	-	492190	11	9	2.1	3448
	25	170	10.2	14000	0	-	10	0	100	FKM	221G2136 ₁₂	2995	481865	-	9	2.0	3448
25	170	10.2	14000	0	-	10	0	100	FKM	221G2136 ₁₂	4270	481000	-	8	2.0	3448	

Notes:

1. Valve only compatible with hydraulic oil and air/neutral gases
2. Valves with model number ending in 30 or 31 are mainly equipped with electrical parts for explosion proof applications or with standard DC coils.
3. With 4 position selector for controlled closure rate.
4. Pilot seat in FKM



For this page	Port size	Orifice (mm)	Kv (l/min)	MOPD (bar)	Fluid Temp (°C)
From	1"	15	80	6	-10
To	1"	25	170	20	120

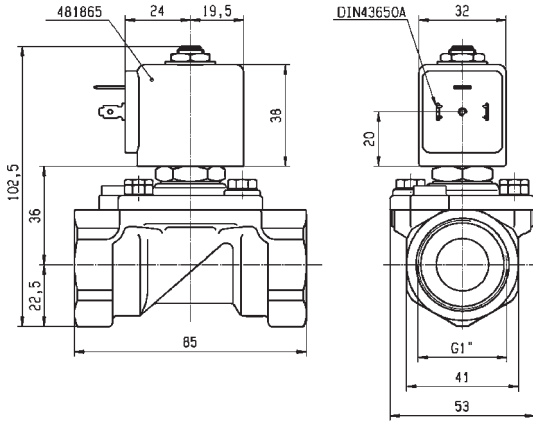

Drawing 3445

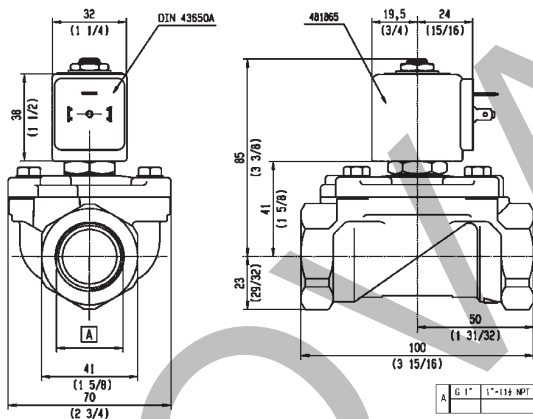

Drawing 3448

2/2

VALVES FOR DRY OR LUBRICATED AIR, NEUTRAL GASES AND LIQUIDS
PILOT OPERATED

BRASS

PIPE MOUNTING

NORMALLY CLOSED

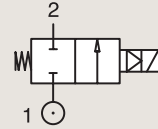

Port size (BSP)	Orifice Ø mm	Flow factors			Operating Pressure Differential Max(MOPD)			Fluid Temp.		Seat Seal	Valve Ref.	Housing Ref.	Coil Ref.	Power		Coil Group	Dwg. No.
		Kv l/min	KV m³/h	Qn m³/h	Min bar	AC bar	DC bar	Min °C	Max °C					AC W	DC W		
		mm	mm	mm	mm	mm	mm	mm	mm					mm	mm		
1/4"	8	36	2.16	1600	0.3	40	25	-10	100	NBR	E321H11 ¹²⁴	2995	481865	8	9	2.0	3523
	8	36	2.16	1600	0.3	40	30	-10	100	NBR	E321H11 ¹²⁴	4270	481000	8	8	2.0	3523
	8	36	2.16	1600	0.3	40	40	-10	100	NBR	E321H11 ¹²⁴	4270	486265	14	14	2.0	3523
	11	28	1.68	1800	0.2	10	3	-10	100	NBR	E321K10 ¹²⁴	2995	481865	8	9	2.0	3429
	11	28	1.68	1800	0.2	10	4	-10	100	NBR	E321K10	4270	481000	8	8	2.0	3429
	12	30	1.8	2150	0.3	10	10	-10	100	NBR	321K31	8993	481180	4	5	1.1	7093
	12	30	1.8	2150	0.3	10	7	-10	75	NBR	321K31	8993	488980	2	2.5	1.1	7093
	12	30	1.8	2150	0.3	10	10	-10	100	FKM	321K3106	8993	481180	4	5	1.1	7093
	12	30	1.8	2150	0.3	10	7	-10	75	FKM	321K3106	8993	488980	2	2.5	1.1	7093
	12	32	1.92	2150	0.3	12	12	-10	100	FKM	321K4156 ³	2995	481865	8	9	2.1/3.0	7094
	12	32	1.92	2150	0.3	12	12	-10	120	FKM	321K4156 ³	4270	481000	8	8	2.1/3.0	7094

Notes:

1. Minimum pressure differential = 0.3 bar for opening and 0 bar for closing
2. Pilot seat disc in synthetic Ruby
3. Valve with manual override
4. With 4 position selector for controlled closure rate

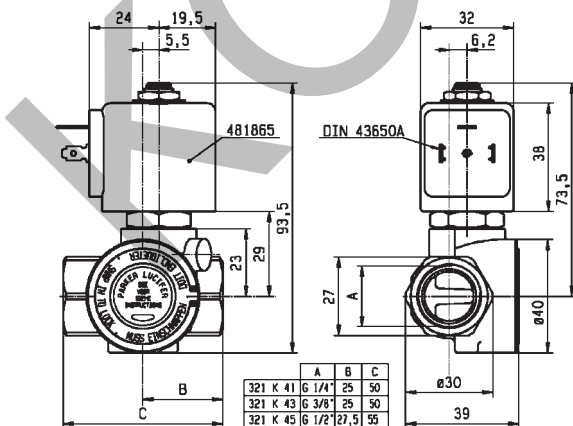

Drawing 7094



For this page	Port size	Orifice (mm)	Kv (l/min)	MOPD (bar)	Fluid Temp (°C)
From	1/4"	8	28	3	-10
To	1/4"	12	36	40	120

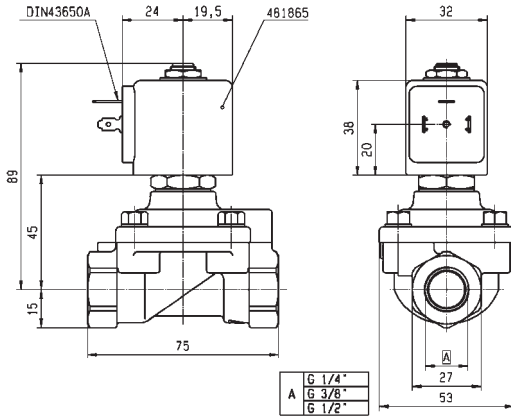

Drawing 3523

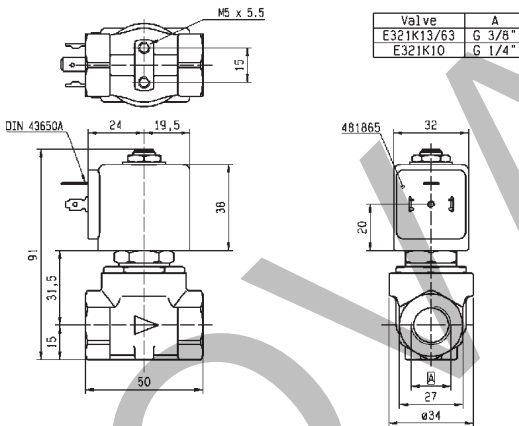

Drawing 3429

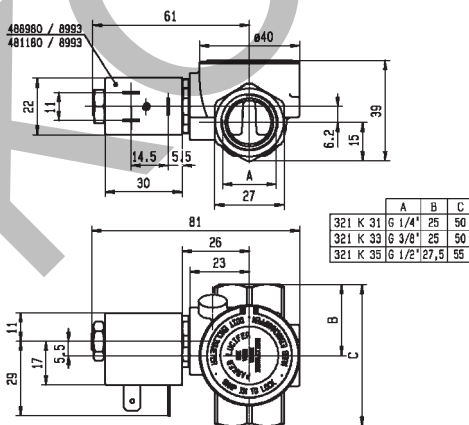

Drawing 7093

2/2

VALVES FOR DRY OR LUBRICATED AIR, NEUTRAL GASES AND LIQUIDS
PILOT OPERATED

BRASS

PIPE MOUNTING

NORMALLY CLOSED

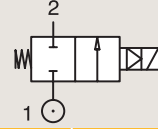

Port size (BSP)	Orifice Ø mm	Flow factors			Operating Pressure Differential Max(MOPD)			Fluid Temp. °C		Seat Seal	Valve Ref.	Housing Ref.	Coil Ref.	Power		Coil Group	Dwg. No.
		Kv l/min	KV m³/h	Qn m³/h	Min bar	AC bar	DC bar	Min °C	Max °C					AC W	DC W		
		3	2800	0.3	40	25	-10	100	NBR					E321H13 ¹²⁴	2995		
3/8"	11	50	3	2800	0.3	40	30	-10	100	NBR	E321H13 ¹²⁴	4270	481000	8	8	2.0	3521
	11	50	3	2800	0.3	40	40	-10	100	NBR	E321H13 ¹²⁴	4270	486265	14	14	2.0	3521
	11	36	2.16	2500	0.2	10	4	-10	100	NBR	E321K13	4270	481000	8	8	2.0	3429
	11	36	2.16	2500	0.2	10	10	-10	100	NBR	E321K13	4270	486265	14	14	2.0	3429
	11	36	2.16	2500	0.2	10	-	-10	100	NBR	E321K1314	2995	483466	8-11	-	2.0	3429
	11	36	2.16	2500	0.2	10	10	-10	100	NBR	E321K1314	4270	486265	14	14	2.0	3429
	12	45	2.7	3050	0.3	10	10	-10	100	NBR	321K33	8993	481180	4	5	1.1	7093
	12	45	2.7	3050	0.3	10	7	-10	75	NBR	321K33	8993	488980	2	2.5	1.1	7093
	12	45	2.7	3050	0.3	10	10	-10	100	FKM	321K3306 ¹	8993	481180	4	5	1.1	7093
	12	45	2.7	3050	0.3	10	7	-10	75	FKM	321K3306 ¹	8993	488980	2	2.5	1.1	7093
	12	45	2.7	3050	0.3	12	12	-10	100	FKM	321K4356 ³	2995	481865	8	9	2.1/3.0	7094
	12	45	2.7	3050	0.3	12	12	-10	120	FKM	321K4356 ³	4270	481000	8	8	2.1/3.0	7094

- Notes:
1. Minimum pressure differential = 0.3 bar for opening and 0 bar for closing
 2. Pilot seat disc in synthetic Ruby
 3. Valve with manual override
 4. With 4 position selector for controlled closure rate

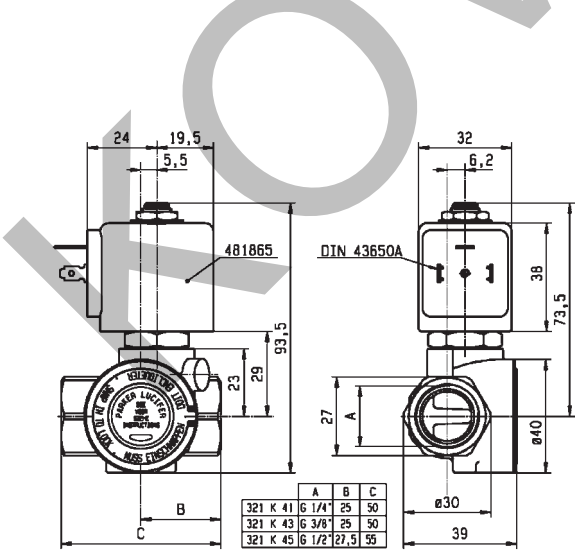

Drawing 7094



For this page	Port size	Orifice (mm)	Kv (l/min)	MOPD (bar)	Fluid Temp (°C)
From	3/8"	11	36	4	-10
To	3/8"	12	50	40	120

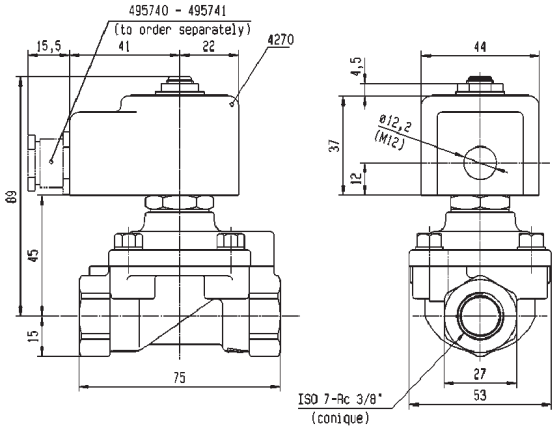

Drawing 3521

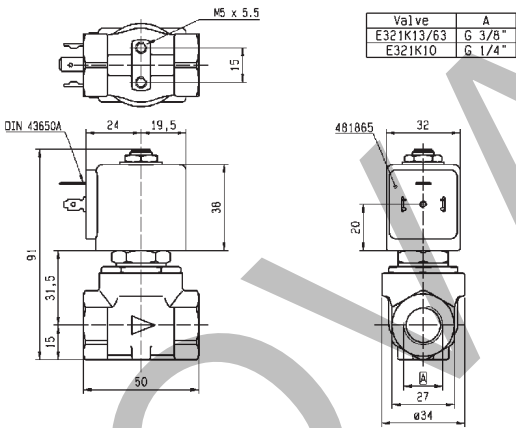

Drawing 3429

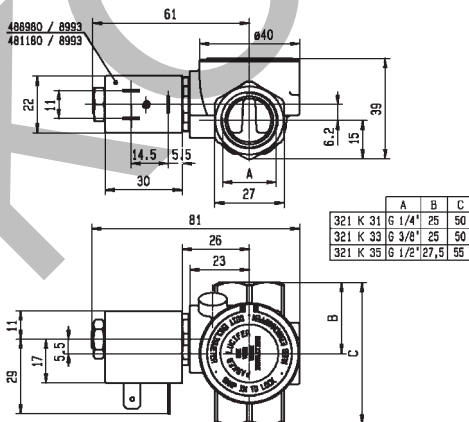

Drawing 7093

2/2

VALVES FOR DRY OR LUBRICATED AIR, NEUTRAL GASES AND LIQUIDS
PILOT OPERATED

BRASS

PIPE MOUNTING

NORMALLY CLOSED

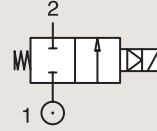

Port size (BSP)	Orifice Ø mm	Flow factors			Operating Pressure Differential Max(MOPD)			Fluid Temp.		Seat Seal	Valve Ref.	Housing Ref.	Coil Ref.	Power		Coil Group	Dwg. No.
		Kv l/min	KV m³/h	Qn m³/h	Min bar	AC bar	DC bar	Min °C	Max °C					AC W	DC W		
		2.16	2500	0.2	10	3	-10	100	NBR					E321K15	2995		
1/2"	11	36	2.16	2500	0.2	10	10	-10	120	NBR	E321K15	4270	486265	14	14	2.0	3427
	11	36	2.16	2500	0.2	10	3	-10	100	FKM	E321K25	2995	481865	8	9	2.0	3427
	11	36	2.16	2500	0.2	4	4	-10	65	FKM	E321K25	-	492070	9	8	2.0	3427
	12	50	3	3400	0.3	12	12	-10	100	NBR	321K35	8993	481180	4	5	1.1	7093
	12	50	3	3400	0.3	10	7	-10	75	NBR	321K35	8993	488980	2	2.5	1.1	7093
	12	50	3	3400	0.3	12	12	-10	100	FKM	321K3506	8993	481180	4	5	1.1	7093
	12	50	3	3400	0.3	10	7	-10	75	FKM	321K3506	8993	488980	2	2.5	1.1	7093
	15	60	3.6	3150	0.3	-	10	-10	55	NBR	321H1590	2995	48358001	-	0.5-3	7.0/8.0	3978
	15	60	3.6	3150	0.3	-	10	-10	80	NBR	321H1590	-	495910	-	0.3-1.2	7.0/8.0	3978
	15	60	3.6	3150	1.5	40	40	-10	50	PUR	321H35 ₂	2995	481865	8	9	2.1	3522
	15	60	3.6	3150	1.5	40	40	-10	50	PUR	321H35 ₂	4270	481000	8	8	2.1	3522
	15	60	3.6	3150	0.3	40	25	-10	100	NBR	E321H15 ¹²⁴	2995	481865	8	9	2.0	3522
	15	60	3.6	3150	0.3	40	30	-10	100	NBR	E321H15 ¹²⁴	4270	481000	8	8	2.0	3522
	15	60	3.6	3150	0.3	40	40	-10	100	NBR	E321H15 ¹²⁴	4270	486265	14	14	2.0	3522

- Notes:
1. Minimum pressure differential = 0.3 bar for opening and 0 bar for closing
 2. Pilot seat disc in synthetic Ruby
 3. Valve with manual override
 4. With 4 position selector for controlled closure rate

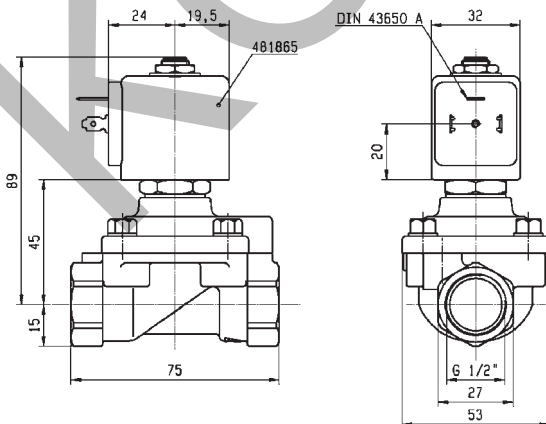

Drawing 3522



For this page	Port size	Orifice (mm)	Kv (l/min)	MOPD (bar)	Fluid Temp (°C)
From	1/2"	11	36	3	-10
To	1/2"	15	60	40	120

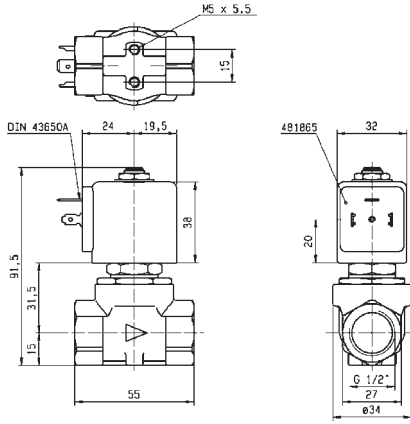

Drawing 3427

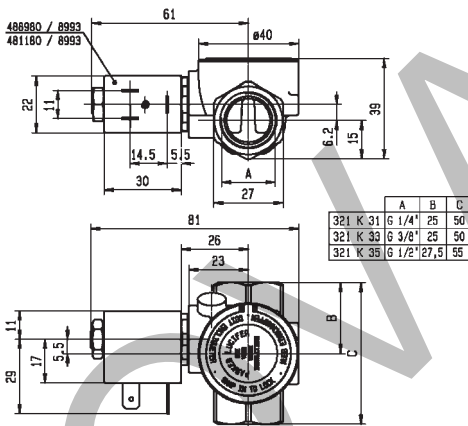

Drawing 7093

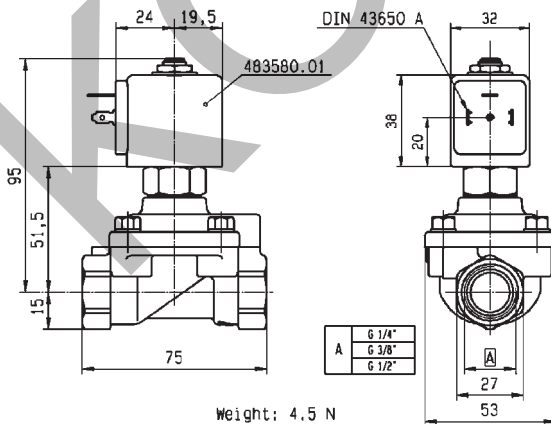

Weight: 4.5 N



Drawing 3978

2/2

VALVES FOR DRY OR LUBRICATED AIR, NEUTRAL
GASES AND LIQUIDS
PILOT OPERATED

BRASS

PIPE MOUNTING

NORMALLY CLOSED

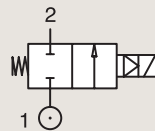

Port size (BSP)	Orifice Ø			Flow factors			Operating Pressure Differential			Fluid Temp.		Seat Seal	Valve Ref.	Housing Ref.	Coil Ref.	Power		Coil Group	Dwg. No.
	mm	Kv l/min	KV m³/h	Qn m³/h	Max(MOPD)			Min	Max	°C	°C					AC W	DC W		
					Min	AC bar	DC bar												
3/4"	15	60	3.6	3550	1.5	40	40	-10	50	PUR	321H36	2995	481865	8	9	2.1	3696		
	15	60	3.6	3550	1.5	40	40	-10	50	PUR	321H36	4270	481000	8	8	2.1	3696		
	18	100	6	9400	0.3	10	10	-10	100	NBR	321K36	8993	481180	4	5	1.1	7097		
	18	100	6	9400	0.3	10	7	-10	75	NBR	321K36	8993	488980	2	2.5	1.1	7097		
	18	100	6	9400	0.3	10	10	-10	100	FKM	321K3606	8993	481180	4	5	1.1	7097		
	18	100	6	9400	0.3	10	7	-10	75	FKM	321K3606	8993	488980	2	2.5	1.1	7097		
	20	135	8.1	9500	0.3	16	16	-10	100	NBR	E321G36	2995	481865	8	9	2.0	3442		
	20	135	8.1	9500	0.3	16	16	-10	100	NBR	E321G36	4270	481000	8	8	2.0	3442		
	20	135	8.1	9500	0.3	16	16	-10	100	FKM	E321G3606	2995	481865	8	9	2.0/14.1	3442		
	20	135	8.1	9500	0.3	16	16	-10	120	FKM	E321G3606	4270	481000	8	8	2.0/14.1	3442		
	20	135	8.1	9500	0.3	16	16	-10	120	FKM	E321G3606	4270	486265	14	14	2.0/14.1	3442		



For this page	Port size	Orifice (mm)	Kv (l/min)	MOPD (bar)	Fluid Temp (°C)
From	3/4"	15	60	7	-10
To	3/4"	20	135	40	120

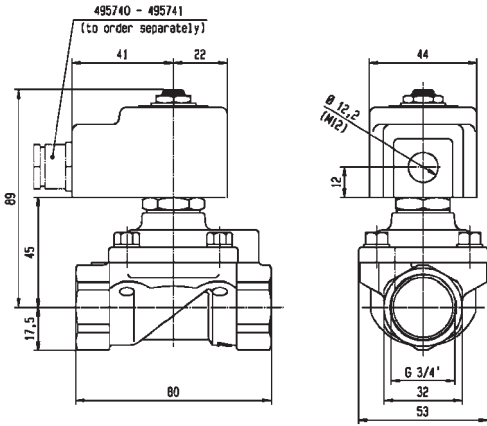

Drawing 3696

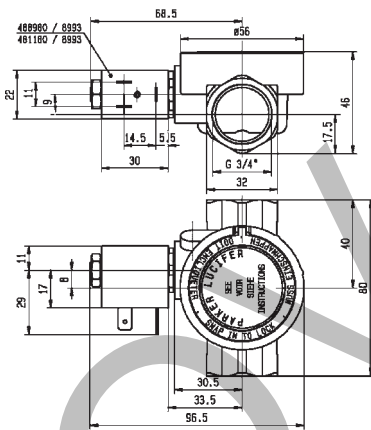

Drawing 7097

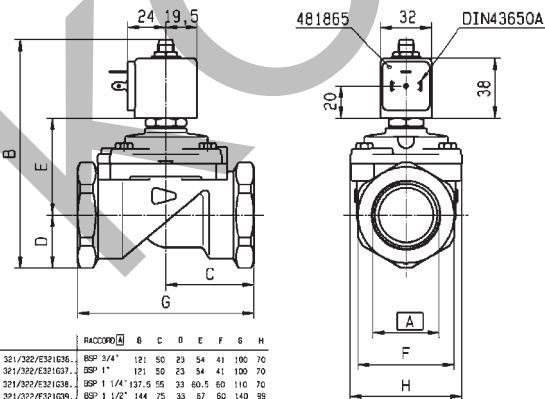

RACCORD	6	C	D	E	F	G	H
321/232/E321636	BSP 3/4"	121	50	23	54	41	100 70
321/332/E331037	OSP 1"	191	50	23	54	41	100 70
321/332/E331038	OSP 1 1/4"	137	55	33	60,5	60	110 70
321/332/E331039	OSP 1 1/2"	144	75	33	87	60	140 59
3212956/C2967	UNF 1 7/8"	144	75	33	87	60	140 59
U321/1322G40...	BSP 2"	158,5	80	41,5	73	75	150 99



Drawing 3442

2/2

VALVES FOR DRY OR LUBRICATED AIR, NEUTRAL
GASES AND LIQUIDS
PILOT OPERATED

BRASS

PIPE MOUNTING

NORMALLY CLOSED

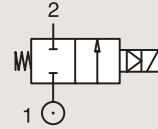

Port size (BSP)	Orifice Ø mm	Flow factors			Operating Pressure Differential			Fluid Temp.		Seat Seal	Valve Ref.	Housing Ref.	Coil Ref.	IS	Power		Coil Group	Dwg. No.
		Kv l/min	KV m ³ /h	Qn m ³ /h	Min bar	Max(MOPD)		Min °C	Max °C						AC W	DC W		
						AC bar	DC bar											
1"	18	110	6.6	10150	0.3	10	10	-10	100	NBR	321K37	8993	481180		4	5	1.1	7098
	18	110	6.6	10150	0.3	10	7	-10	75	NBR	321K37	8993	488980		2	2.5	1.1	7098
	18	110	6.6	10150	0.3	10	10	-10	100	FKM	321K3706	8993	481180		4	5	1.1	7098
	18	110	6.6	10150	0.3	10	7	-10	75	FKM	321K3706	8993	488980		2	2.5	1.1	7098
	25	185	11.1	14100	0.3	-	10	-10	55	NBR	321G3790 ₁	2995	48358001	*	0.5- 3		7.0/8.0	3442
	25	185	11.1	14100	0.3	-	10	-10	75	NBR	321G3790 ₁	-	495910	*	0.3- 1.2		7.0/8.0	3442
	25	180	10.8	14000	0.3	16	16	-10	100	NBR	E321G37	2995	481865		8	9	2.0	3442
	25	180	10.8	14000	0.3	16	16	-10	100	NBR	E321G37	4270	481000		8	8	2.0	3442
	25	180	10.8	14000	0.3	16	16	-10	100	FKM	E321G3706	2995	481865		8	9	2.0/14.1	3442
	25	180	10.8	14000	0.3	16	16	-10	120	FKM	E321G3706	4270	481000		8	8	2.0/14.1	3442
1 1/4"	28	270	16.2	18000	0.3	16	16	-10	100	NBR	E321G38	2995	481865		8	9	2.0	3442
	28	270	16.2	18000	0.3	16	16	-10	100	NBR	E321G38	4270	481000		8	8	2.0	3442
	28	270	16.2	18000	0.3	16	16	-10	100	FKM	E321G3806	2995	481865		8	9	2.0	3442
	28	270	16.2	18000	0.3	16	16	-10	120	FKM	E321G3806	4270	481000		8	8	2.0	3442
	28	270	16.2	18000	0.3	16	16	-10	100	FKM	E321G3806	4270	486265		14	14	2.0	3442

Notes:

1. Pilot seat disc in FKM



For this page	Port size	Orifice (mm)	Kv (l/min)	MOPD (bar)	Fluid Temp (°C)
From	1"	18	110	7	-10
To	1 1/4"	28	270	16	120

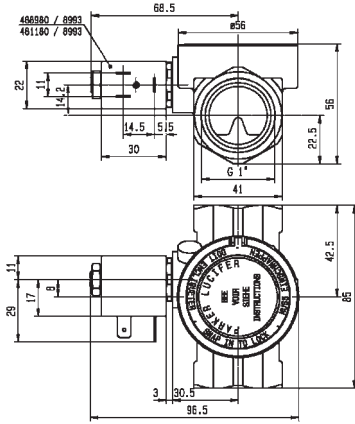

Drawing 7098

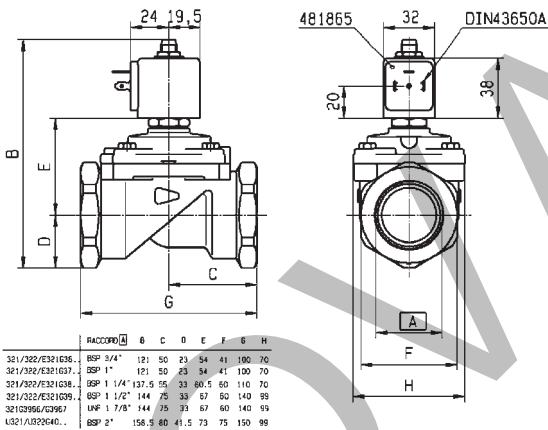

Drawing 3442

2/2

VALVES FOR DRY OR LUBRICATED AIR, NEUTRAL GASES AND LIQUIDS
PILOT OPERATED

BRASS

PIPE MOUNTING

NORMALLY CLOSED

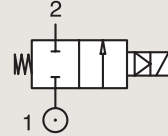

Port size (BSP)	Orifice Ø mm	Flow factors			Operating Pressure Differential Max(MOPD)			Fluid Temp.		Seat Seal	Valve Ref.	Housing Ref.	Coil Ref.	IS	Power		Coil Group	Dwg. No.
		Kv l/min	KV m ² /h	Qn m ³ /h	Min bar	AC bar	DC bar	Min °C	Max °C						AC W	DC W		
1 1/2"	40	425	25.5	31500	0.5	-	10	-10	55	NBR	321G3990	2995	48358001	*	-	0.5-3	7.0/8.0	8113
	40	425	25.5	31500	0.5	-	10	-10	75	NBR	321G3990	-	495910	*	-	0.3-1.2	7.0/8.0	8113
	40	420	25.2	31500	0.3	16	7	-10	100	NBR	E321G39 ₁	2995	481865	8	9	2.0	3442	
	40	420	25.2	31500	0.3	16	8	-10	100	NBR	E321G39 ₁	4270	481000	8	8	2.0	3442	
	40	420	25.2	31500	0.3	16	16	-10	100	NBR	E321G39 ₁	4270	486265	14	14	2.0	3442	
	40	420	25.2	31500	0.3	16	7	-10	100	FKM	E321G3906	2995	481865	8	9	2.0	3442	
	40	420	25.2	31500	0.3	16	8	-10	120	FKM	E321G3906	4270	481000	8	8	2.0	3442	
	40	420	25.2	31500	0.3	16	16	-10	100	FKM	E321G3906	4270	486265	14	14	2.0	3442	
2"	40	540	32.4	38100	0.5	-	10	-10	55	FKM	321G4090	2995	48358001	*	-	0.5-3	7.0/8.0	8113
	40	540	32.4	38100	0.5	-	10	-10	75	FKM	321G4090	-	495910	*	-	0.3-1.2	7.0/8.0	8113
	40	540	32.4	40000	0.3	16	7	-10	100	NBR	E321G40 ₁	2995	481865	8	9	2.0	3442	
	40	540	32.4	40000	0.3	16	8	-10	100	NBR	E321G40 ₁	4270	481000	8	8	2.0	3442	
	40	540	32.4	40000	0.3	16	16	-10	100	NBR	E321G40 ₁	4270	486265	14	14	2.0	3442	
	40	540	32.4	40000	0.3	16	7	-10	100	FKM	E321G4006	2995	481865	8	9	2.0	3442	
	40	540	32.4	40000	0.3	16	8	-10	120	FKM	E321G4006	4270	481000	8	8	2.0	3442	
	40	540	32.4	40000	0.3	16	16	-10	120	FKM	E321G4006	4270	486265	14	14	2.0	3442	

Notes:

1. Pilot seat disc in synthetic Ruby



For this page	Port size	Orifice (mm)	Kv (l/min)	MOPD (bar)	Fluid Temp (°C)
From	1 1/2"	40	420	7	-10
To	2"	40	540	16	120

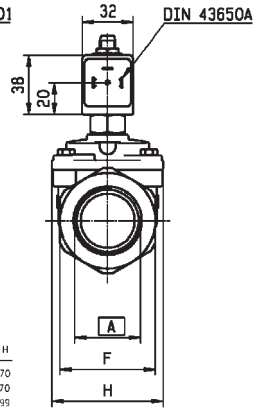
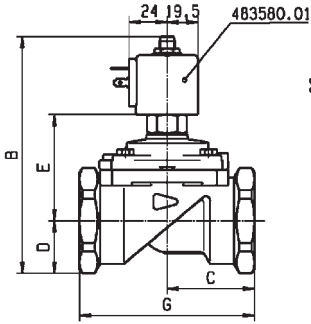

	RACCORD(A)	B	C	D	E	F	G	H
U321G3690	BSP 3/4"	135	50	23	54	41	100	70
321G3750	BSP 1"	135	50	23	54	41	100	70
321/U321G3690	BSP 1 1/2"	158	75	33	67	60	140	99
321/U321G4090	BSP 2"	172.5	60	41.5	73	75	150	99

Drawing 8113

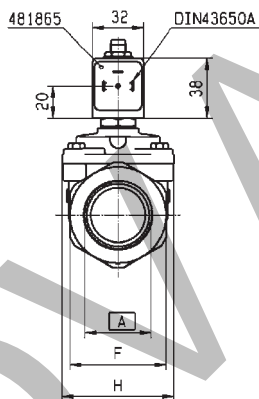
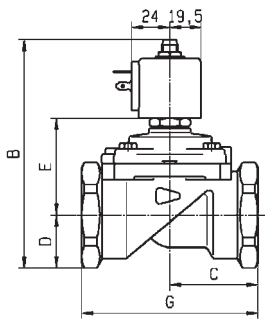

	RACCORD(A)	B	C	D	E	F	G	H
321/322/E321G36	BSP 3/4"	121	50	23	54	41	100	70
321/322/E321G37	BSP 1"	121	50	23	54	41	100	70
321/322/E321G38	BSP 1 1/4"	137.5	55	33	60.5	60	110	70
321/322/E321G39	BSP 1 1/2"	144	75	33	67	60	140	99
321G3965/G3967	1/4" 1.7/8"	144	75	33	67	60	140	99
U321/U320G40	BSP 2"	156.5	60	41.5	73	75	150	99

Drawing 3442

2/2

VALVES FOR DRY OR LUBRICATED AIR, NEUTRAL GASES AND LIQUIDS

PILOT OPERATED

BRASS

PIPE MOUNTING

NORMALLY OPEN

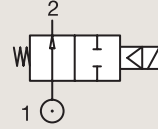

Port size (BSP)	Orifice Ø mm	Flow factors			Operating Pressure Differential Max(MOPD)			Fluid Temp.		Seat Seal	Valve Ref.	Housing Ref.	Coil Ref.	Power		Coil Group	Dwg. No.
		Kv l/min	KV m³/h	Qn m³/h	Min bar	AC bar	DC bar	Min °C	Max °C					AC W	DC W		
		1600	1600	1600	0.3	40	25	-10	100					8	9		
1/4"	8	36	2.16	1600	0.3	40	25	-10	100	NBR	322H71 ₁₂	2995	481865	8	9	2.0	3523
	8	36	2.16	1600	0.3	40	30	-10	100	NBR	322H71 ₁₂	4270	481000	8	8	2.0	3523
	8	36	2.16	1600	0.3	40	40	-10	100	NBR	322H71 ₁₂	4270	486265	14	14	2.0	3523
	8	36	2.16	1600	0.3	40	40	-10	100	FKM	322H7106 ₁₂	2995	481865	8	9	2.0/14.1	3523
	8	36	2.16	1600	0.3	40	40	-10	120	FKM	322H7106 ₁₂	4270	481000	8	8	2.0/14.1	3523
	8	36	2.16	1600	0.3	40	40	-10	140	FKM	322H7106 ₁₂	4270	486265	14	14	2.0/14.1	3523
3/8"	11	50	3	3240	0.3	40	40	-10	75	NBR	322H73 ₁₂	2995	481865	8	9	2.0	3523
	11	50	3	3240	0.3	40	40	-10	75	NBR	322H73 ₁₂	4270	481000	8	8	2.0	3523
	11	50	3	3240	0.3	40	40	-10	75	NBR	322H73 ₁₂	4270	486265	14	14	2.0	3523
	11	50	3	3240	0.3	40	40	-10	100	FKM	322H7306 ₁₂	2995	481865	8	9	2.0/14.1	3523
	11	50	3	3240	0.3	40	40	-10	100	FKM	322H7306 ₁₂	4270	481000	8	8	2.0/14.1	3523
	11	50	3	3240	0.3	40	40	-10	140	FKM	322H7306 ₁₂	4270	486265	14	14	2.0/14.1	3523
1/2"	15	60	3.6	3890	0.3	15	15	-10	100	NBR	322G75	2995	481865	8	9	2.1	3522
	15	60	3.6	3890	0.3	15	15	-10	100	NBR	322G75	4270	481000	8	8	2.1	3522
	15	60	3.6	3890	0.3	20	20	-10	100	FKM	322G7506 ₁	2995	481865	8	9	2.0	3522
	15	60	3.6	3890	0.3	20	20	-10	100	FKM	322G7506 ₁	4270	481000	8	8	2.0	3522
	15	60	3.6	3890	0.3	20	20	-10	100	FKM	322G7506 ₁	4270	486265	14	14	2.0	3522
	15	60	3.6	3150	1.5	40	40	-10	50	PUR	322H35 ₃	2995	481865	8	9	2.1	7569
	15	60	3.6	3150	1.5	40	40	-10	50	PUR	322H35 ₃	4270	481000	8	8	2.1	7569
	15	60	3.6	3890	0.3	40	40	-10	100	NBR	322H75 ₁₂	2995	481865	8	9	2.0	3522
	15	60	3.6	3890	0.3	40	40	-10	100	NBR	322H75 ₁₂	4270	481000	8	8	2.0	3522
	15	60	3.6	3890	0.3	40	40	-10	100	NBR	322H75 ₁₂	4270	486265	14	14	2.0	3522
	15	60	3.6	3890	0.3	40	40	-10	100	FKM	322H7506 ₁₂	2995	481865	8	9	2.0/14.1	3522
	15	60	3.6	3890	0.3	40	40	-10	120	FKM	322H7506 ₁₂	4270	481000	8	8	2.0/14.1	3522
	15	60	3.6	3890	0.3	40	40	-10	140	FKM	322H7506 ₁₂	4270	486265	14	14	2.0/14.1	3522

Notes:

1. Minimum pressure differential = 0.3 bar for opening and 0 bar for closing
2. Pilot seat disc in synthetic Ruby
3. Valve only compatible with air and neutral gases



For this page	Port size	Orifice (mm)	Kv (l/min)	MOPD (bar)	Fluid Temp (°C)
From	1/4"	8	36	15	-10
To	1/2"	15	60	40	140

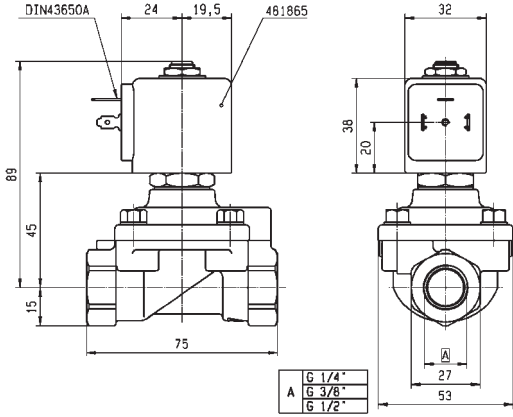

Drawing 3523

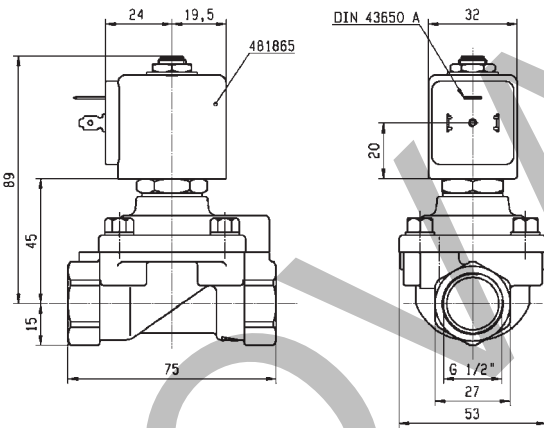

Drawing 3522

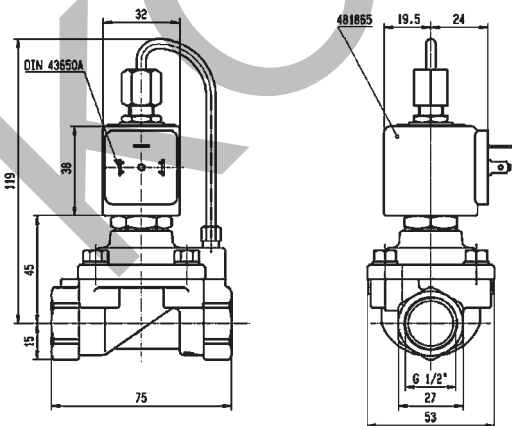

Drawing 7569

2/2

VALVES FOR DRY OR LUBRICATED AIR, NEUTRAL
GASES AND LIQUIDS
PILOT OPERATED

BRASS

PIPE MOUNTING

NORMALLY OPEN

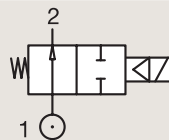

Port size (BSP)	Orifice Ø mm	Flow factors			Operating Pressure Differential Max(MOPD)			Fluid Temp.		Seat Seal	Valve Ref.	Housing Ref.	Coil Ref.	Power		Coil Group	Dwg. No.
		Kv l/min	KV m ³ /h	Qn m ³ /h	Min bar	AC bar	DC bar	Min °C	Max °C					AC W	DC W		
		3.2	3.2	3550	1.5	40	40	-10	50					8	9		
3/4"	15	53.3	3.2	3550	1.5	40	40	-10	50	PUR	322H36 ¹²	2995	481865	8	9	2.1	7570
	15	53.3	3.2	3550	1.5	40	40	-10	50	PUR	322H36 ¹²	4270	481000	8	8	2.1	7570
	20	135	8.1	9500	0.3	16	16	-10	100	NBR	322G36	2995	481865	8	9	2.1	3442
	20	135	8.1	9500	0.3	16	16	-10	100	NBR	322G36	4270	481000	8	8	2.1	3442
	20	135	8.1	9500	0.3	16	16	-10	100	FKM	322G3606	2995	481865	8	9	2.1	3442
	20	135	8.1	9500	0.3	16	16	-10	120	FKM	322G3606	4270	481000	8	8	2.1	3442
1"	25	180	10.8	14000	0.3	16	16	-10	100	NBR	322G37	2995	481865	8	9	2.1	3442
	25	180	10.8	14000	0.3	16	16	-10	100	NBR	322G37	4270	481000	8	8	2.1	3442
	25	180	10.8	14000	0.3	16	16	-10	100	FKM	322G3706	2995	481865	8	9	2.1	3442
	25	180	10.8	14000	0.3	16	16	-10	120	FKM	322G3706	4270	481000	8	8	2.1	3442
1 1/4"	28	270	16.2	18000	0.3	16	16	-10	100	NBR	322G38	2995	481865	8	9	2.1	3442
	28	270	16.2	18000	0.3	16	16	-10	100	NBR	322G38	4270	481000	8	8	2.1	3442
	28	270	16.2	18000	0.3	16	16	-10	100	FKM	322G3806	2995	481865	8	9	2.1	3442
	28	270	16.2	18000	0.3	16	16	-10	120	FKM	322G3806	4270	481000	8	8	2.1	3442
1 1/2"	40	420	25.2	31500	0.3	12	12	-10	100	NBR	322G39	2995	481865	8	9	2.1	3442
	40	420	25.2	31500	0.3	12	12	-10	100	NBR	322G39	4270	481000	8	8	2.1	3442
	40	420	25.2	31500	0.3	12	12	-10	100	FKM	322G3906	2995	481865	8	9	2.1	3442
	40	420	25.2	31500	0.3	12	12	-10	100	FKM	322G3906	4270	481000	8	8	2.1	3442
2"	40	540	32.4	40000	0.3	12	12	-10	100	NBR	322G40	2995	481865	8	9	2.1	3442
	40	540	32.4	40000	0.3	12	12	-10	100	NBR	322G40	4270	481000	8	8	2.1	3442
	40	540	32.4	40000	0.3	12	12	-10	100	FKM	322G4006	2995	481865	8	9	2.1	3442
	40	540	32.4	40000	0.3	12	12	-10	120	FKM	322G4006	4270	481000	8	8	2.1	3442

Notes:

1. Minimum pressure differential = 1.5 bar for opening and 0.3 bar for closing
2. Valve only compatible with air and neutral gases



For this page	Port size	Orifice (mm)	Kv (l/min)	MOPD (bar)	Fluid Temp (°C)
From	3/4"	15	53.3	12	-10
To	2"	40	540	40	120

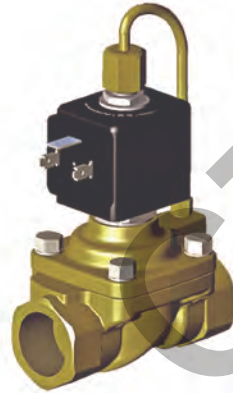
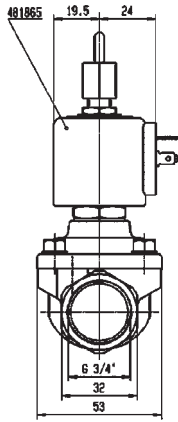
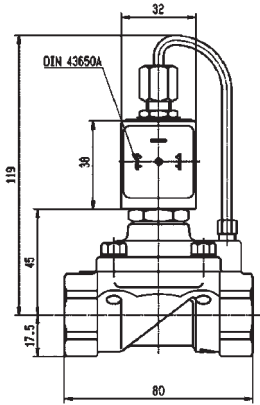

Drawing 7570

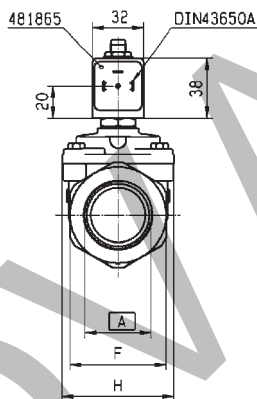
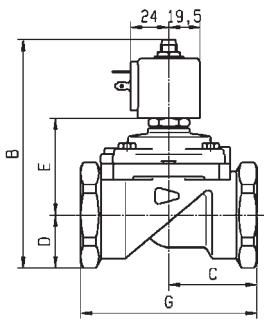

Drawing 3442

RACCORD	G	C	D	E	F	G	H
321/322/E321G36..	BSPP 3/4"	121	50	21	54	41	100 70
321/332/E321G37..	BSPP 1"	121	50	23	54	41	100 70
321/330/E321G38..	BSPP 1 1/4"	137.5	55	33	60.5	60	110 70
321/332/E321G39..	BSPP 1 1/2"	144	75	33	67	60	140 99
321/336/E321G40..	1 1/2"	144	75	33	67	60	140 99
U321/AU320G40..	BSPP 2"	156.5	80	41.5	73	75	150 99

2/2

VALVES FOR DRY OR LUBRICATED AIR, NEUTRAL
GASES AND LIQUIDS
PILOT OPERATED

BRASS

PIPE MOUNTING

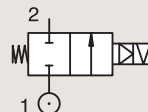

CONTROL BY ELECTRIC IMPULSE

Port size	Orifice Ø	Flow factors			Operating Pressure Differential			Fluid Temp.		Seat Seal	Valve Ref.	Housing Ref.	Coil Ref.	Power		Coil Group	Dwg. No.
		Kv l/min	KV m³/h	Qn l/min	Min bar	Max (MOPD) AC bar	DC bar	Min °C	Max °C					AC W	DC W		
1/4"	12	32	1.92	2150	0.3	12	-	-10	100	FKM	325K4106	4269	484990	11	-	4.0	7094
	12	32	1.92	2150	0.3	-	12	-10	100	FKM	325K4106	4269	485400	-	13	4.0	7094
3/8"	12	45	2.7	3050	0.3	12	-	-10	100	FKM	325K4306	4269	484990	11	-	4.0	7094
	12	45	2.7	3050	0.3	-	12	-10	100	FKM	325K4306	4269	485400	-	13	4.0	7094
1/2"	12	50	3	3400	0.3	12	-	-10	100	FKM	325K4506	4269	484990	11	-	4.0	7094
	12	50	3	3400	0.3	-	12	-10	100	FKM	325K4506	4269	485400	-	13	4.0	7094
3/4"	18	100	6	9400	0.3	12	-	-10	100	FKM	325K4606	4269	484990	11	-	4.0	7099
	18	100	6	9400	0.3	-	12	-10	100	FKM	325K4606	4269	485400	-	13	4.0	7099
1"	18	110	6.6	10150	0.3	12	-	-10	100	FKM	325K4706	4269	484990	11	-	4.0	7100
	18	110	6.6	10150	0.3	-	12	-10	100	FKM	325K4706	4269	485400	-	13	4.0	7100



For this page	Port size	Orifice (mm)	Kv (l/min)	MOPD (bar)	Fluid Temp (°C)
From	1/4"	12	32	12	-10
To	1"	18	110	12	100

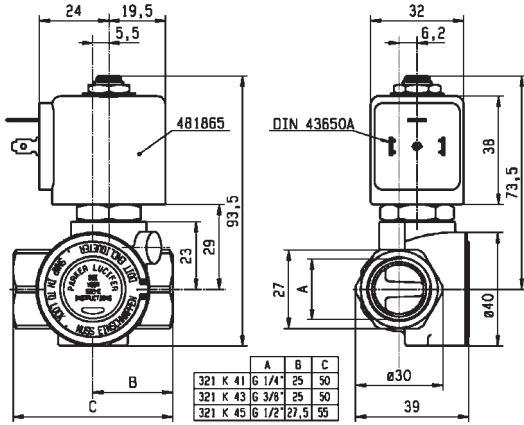

Drawing 7094

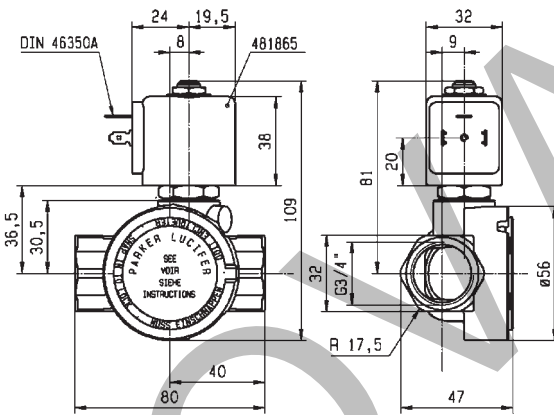

Drawing 7099

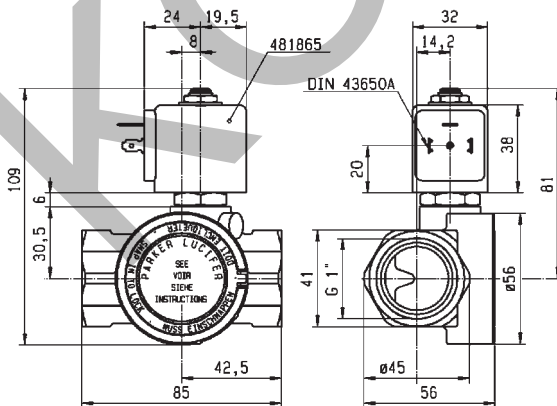

Drawing 7100

2/2

VALVES FOR DRY OR LUBRICATED AIR, NEUTRAL GASES AND LIQUIDS

PILOT OPERATED

BRASS

SUB-BASE MOUNTING

NORMALLY CLOSED

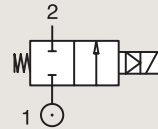

Port size	Orifice Ø mm	Flow factors			Operating Pressure Differential Max(MOPD)			Fluid Temp.		Seat Seal	Valve Ref.	Housing Ref.	Coil Ref.	Power		Coil Group	Dwg. No.
		Kv l/min	KV m³/h	Qn l/min	Min	Max	Min	Max	AC W					DC W			
		bar	AC bar	DC bar	°C	°C											
SB	14	-	-	2100	1.5	40	40	-10	50	PUR	321F35	2995	481865	8	9	2.0	3520
	14	-	-	2100	1.5	40	40	-10	50	PUR	321F35	2995	492425	14	14	2.0	3520
	14	-	-	2100	0	13	13	-10	50	PUR	421F35	2995	481865	8	9	2.1	3520
	14	45	2.7	2100	0.3	40	25	-10	100	NBR	E321F32 ²	2995	481865	8	9	2.0	3520
	14	45	2.7	2100	0.3	40	30	-10	100	NBR	E321F32 ²	4270	481000	8	8	2.0	3520
	14	45	2.7	2100	0.3	40	40	-10	100	NBR	E321F32 ²	4270	486265	14	14	2.0	3520
	14	45	2.7	-	0.3	40	25	-10	100	FKM	E321F3202 ¹²³⁴	2995	481865	8	9	2.0	3520
	14	45	2.7	-	0.3	40	30	-10	120	FKM	E321F3202 ¹²³⁴	4270	481000	8	8	2.0	3520
	14	45	2.7	-	0.3	40	40	-10	140	FKM	E321F3202 ¹²³⁴	4270	486265	14	14	2.0	3520

Notes:

1. Minimum pressure differential = 0.3 bar for opening and 0 bar for closing
2. Pilot seat disc in synthetic Ruby
3. Valve only compatible with hydraulic oil and neutral liquids
4. With 4 position selector for controlled closure rate

BRASS

SUB-BASE MOUNTING

NORMALLY OPEN

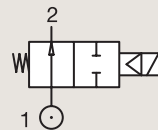

Port size	Orifice Ø mm	Flow factors			Operating Pressure Differential Max(MOPD)			Fluid Temp.		Seat Seal	Valve Ref.	Housing Ref.	Coil Ref.	Power		Coil Group	Dwg. No.
		Kv l/min	KV m³/h	Qn l/min	Min	Max	Min	Max	AC W					DC W			
		bar	AC bar	DC bar	°C	°C											
SB	14	-	-	2100	1.5	40	40	-10	50	PUR	322F35	2995	481865	8	9	2.1	7527
	14	46	2.76	-	0.3	40	40	-10	75	NBR	322F72 ¹²⁴	2995	481865	8	9	2.1	3520
	14	46	2.76	-	0.3	40	40	-10	75	NBR	322F72 ¹²⁴	4270	481000	8	8	2.1	3520
	14	45	2.7	-	0.3	40	40	0	100	FKM	322F7206 ¹²³⁴	2995	481865	8	9	2.1/14.1	3520
	14	45	2.7	-	0.3	40	40	0	120	FKM	322F7206 ¹²³⁴	4270	481000	8	8	2.1/14.1	3520

Notes:

1. Minimum pressure differential = 0.3 bar for opening and 0 bar for closing
2. Pilot seat disc in synthetic Ruby
3. Valve only compatible with hydraulic oil and neutral liquids
4. With 4 position selector for controlled closure rate



For this page	Port size	Orifice (mm)	Kv (l/min)	MOPD (bar)	Fluid Temp (°C)
From	14 mm	14	-	13	-10
To	14 mm	14	46	40	140

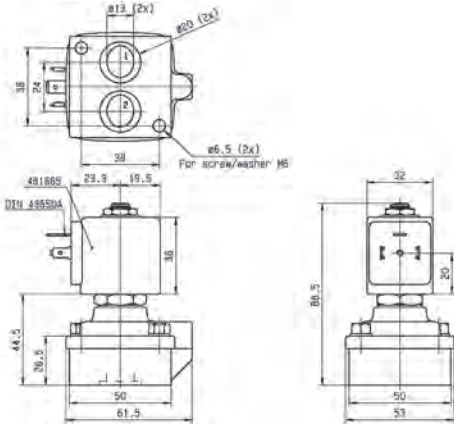

Drawing 3520

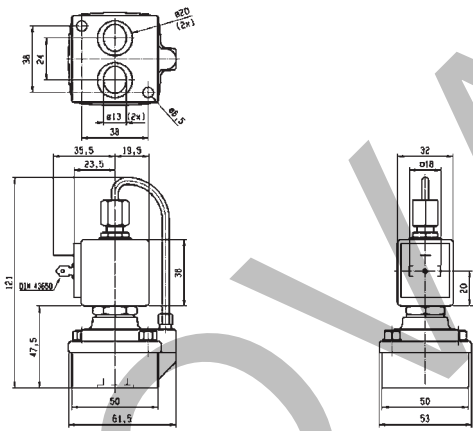

Drawing 7527

VALVES FOR WATER AND NEUTRAL LIQUIDS



2/2

Actuation	Body	Function	Port Size	Orifice (mm)	Flow Factor Kv(l/min)	MOPD (bar)	Max Fluid Temp. (°C)	Page Parker Valves		
Direct Operated	Brass/Pipe Mounting	Normally Closed	1/8"	1.5 to 2	2	20	75	62		
			1/4"	1.5 to 5	11	20	120	62		
			3/8"	4 to 6	12	10	120	64		
			1/2"	8.5 to 11	36	4	120	64		
		Normally Open	1/4"	2.5	3	12	120	64		
		Control by Electric Impulse	1/4"	5	11	5	100	66		
	Brass/Sub-base Mounting	Normally Closed	5 mm	1.5 to 3	4.5	20	120	68		
Pilot Operated	Brass/Pipe Mounting	Normally Closed	1/4"	11 to 12	32	12	120	74		
			3/8"	11 to 13	50	20	140	70 and 74		
			1/2"	11 to 13	50	20	140	70 and 76		
			3/4"	18 to 20	140	20	140	70 and 78		
			1"	18 to 25	180	20	140	70 and 80		
			1 1/4"	28 to 35	420	16	140	72 and 80		
			1 1/2"	40	500	16	140	72 and 80		
			2"	40 to 50	620	16	140	72 and 80		
			Normally Open	1/4"	12	32	12	120	84	
			3/8"	12 to 13	50	20	140	82 and 84		
		1/2"	12 to 15	60	20	140	82 and 84			
		3/4"	18 to 20	140	20	140	82 and 84			
		1"	18 to 25	180	20	140	80 and 86			
		1 1/4"	35	420	10	140	82			
		1 1/2"	40	500	10	140	82 and 86			
		2"	50	620	10	140	82			
		2 1/2"	65	1100	10	90	82			
		3"	75	1334	10	90	82			
			Brass/Sub-base Mounting	Normally Closed	14 mm	14	45	40	100	86

2/2

VALVES FOR WATER AND NEUTRAL LIQUIDS DIRECT OPERATED

BRASS

PIPE MOUNTING

NORMALLY CLOSED

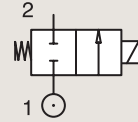

Port size	Orifice Ø	Flow factors			Operating Pressure Differential			Fluid Temp.		Seat Seal	Valve Ref.	Housing Ref.	Coil Ref.	Power		Coil Group	Dwg. No.
		Kv l/min	KV m³/h	Qn l/min	Min bar	Max(MOPD) AC bar	DC bar	Min °C	Max °C					AC W	DC W		
1/8"	1.5	0.9	0.05	70	0	20	12	-10	75	FKM	121M14	8993	481180	4	5	1.1	3382
	1.5	0.9	0.05	70	0	20	4	-10	75	FKM	121M14	8993	488980	2	2.5	1.1	3382
	2	2	0.12	125	0	10	7	-10	75	FKM	121M13	8993	481180	4	5	1.1	3382
	2	2	0.12	125	0	10	2.5	-10	75	FKM	121M13	8993	488980	2	2.5	1.1	3382
1/4"	1.5	1.5	0.09	80	0	20	20	-10	100	FKM	E121K0402	2995	481865	8	9	2.0/3.0	3510
	1.5	1.5	0.09	80	0	20	20	-10	120	FKM	E121K0402	4270	481000	8	8	2.0/3.0	3510
	2.5	3.5	0.21	220	0	14	7	-10	100	FKM	121K0706	2995	481865	8	9	2.0	3510
	2.5	3.5	0.21	220	0	14	9	-10	120	FKM	121K0706	4270	481000	8	8	2.0	3510
	2.5	3.5	0.21	220	0	14	14	-10	120	FKM	121K0706	4270	486265	14	14	2.0	3510
	3	4.5	0.27	320	0	10	7	-10	100	FKM	E121K0302	2995	481865	8	9	2.0	3510
	3	4.5	0.27	320	0	10	8.5	-10	120	FKM	E121K0302	4270	481000	8	8	2.0	3510
	3	4.5	0.27	320	0	10	7	-10	100	FKM	E121K0302	4270	486265	14	14	2.0	3510
	3	4.5	0.27	320	0	10	7	-10	100	FKM	E121K0352 ₁	2995	481865	8	9	2.0	3510
	3	4.5	0.27	320	0	10	8.5	-10	120	FKM	E121K0352 ₁	4270	481000	8	8	2.0	3510
	3	4.5	0.27	320	0	10	10	-10	120	FKM	E121K0352 ₁	4270	486265	14	14	2.0	3510
	4	7.5	0.45	480	0	10	4	-10	100	FKM	121K02	2995	481865	8	9	2.0	3510
	4	7.5	0.45	480	0	10	5	-10	120	FKM	121K02	4270	481000	8	8	2.0	3510
	4	7.5	0.45	480	0	10	10	-10	120	FKM	121K02	4270	486265	14	14	2.0	3510
	4	7.5	0.45	480	0	10	4	-10	100	FKM	121K0250 ₁	2995	481865	8	9	2.0	3510
	4	7.5	0.45	480	0	10	5	-10	120	FKM	121K0250 ₁	4270	481000	8	8	2.0	3510
	4	7.5	0.45	480	0	10	10	-10	120	FKM	121K0250 ₁	4270	486265	14	14	2.0	3510
	5	11	0.66	750	0	7	2	-10	100	FKM	121K01	2995	481865	8	9	2.0/14.2	3510
	5	11	0.66	750	0	7	2.8	-10	120	FKM	121K01	4270	481000	8	8	2.0/14.2	3510
	5	11	0.66	750	0	7	5	-10	120	FKM	121K01	4270	486265	14	14	2.0/14.2	3510
5	11	0.66	750	0	7	2	-10	100	FKM	121K0150 ₁	2995	481865	8	9	2.0	3510	
5	11	0.66	750	0	7	2.8	-10	120	FKM	121K0150 ₁	4270	481000	8	8	2.0	3510	
5	11	0.66	750	0	7	5	-10	120	FKM	121K0150 ₁	4270	486265	14	14	2.0	3510	

Notes:
1. With manual override



For this page	Port size	Orifice (mm)	Kv (l/min)	MOPD (bar)	Fluid Temp (°C)
From	1/8"	1.5	0.9	2	-10
To	1/4"	5	11	20	120

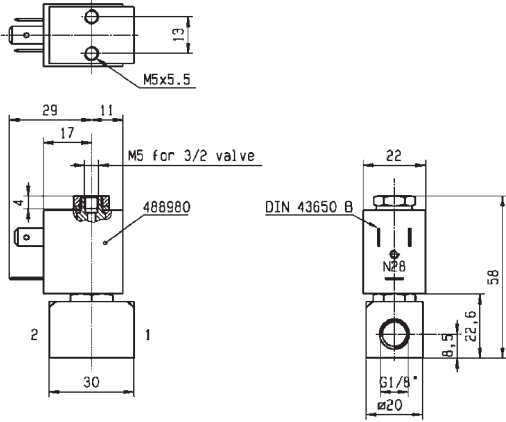

Drawing 3382

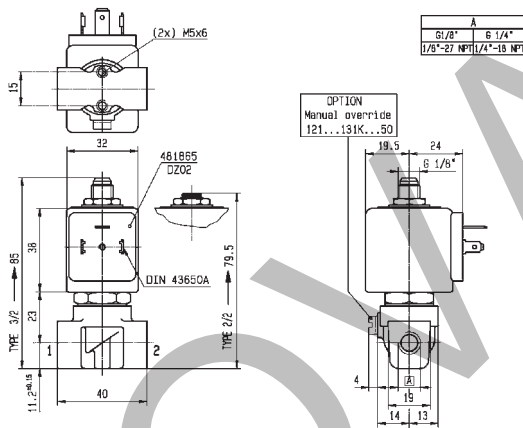

Drawing 3510

2/2

VALVES FOR WATER AND NEUTRAL LIQUIDS

DIRECT OPERATED

BRASS

PIPE MOUNTING

NORMALLY CLOSED

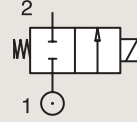

Port size	Orifice Ø	Flow factors			Operating Pressure Differential			Fluid Temp.		Seat Seal	Valve Ref.	Housing Ref.	Coil Ref.	Power		Coil Group	Dwg. No.
		Kv l/min	KV m³/h	Qn l/min	Min bar	Max(MOPD) AC bar	DC bar	Min °C	Max °C					AC W	DC W		
3/8"	4	7.5	0.45	480	0	10	4	-10	100	FKM	121K3206	2995	481865	8	9	2.0	3551
	4	7.5	0.45	480	0	10	5	-10	120	FKM	121K3206	4270	481000	8	8	2.0	3551
	4	7.5	0.45	480	0	10	10	-10	120	FKM	121K3206	4270	486265	14	14	2.0	3551
	5	11	0.66	750	0	7	2	-10	100	FKM	121K3106	2995	481865	8	9	2.0	3551
	5	11	0.66	750	0	7	2.8	-10	120	FKM	121K3106	4270	481000	8	8	2.0	3551
	5	11	0.66	750	0	7	5	-10	120	FKM	121K3106	4270	486265	14	14	2.0	3551
	6	12	0.72	1100	0	5	1.1	-10	100	FKM	121K3306	2995	481865	8	9	2.0/14.2	3551
	6	12	0.72	1100	0	5	1.5	-10	120	FKM	121K3306	4270	481000	8	8	2.0/14.2	3551
	6	12	0.72	1100	0	5	3	-10	120	FKM	121K3306	4270	486265	14	14	2.0/14.2	3551
1/2"	8.5	25	1.5	1600	0	1.1	0.5	-10	100	FKM	E121K46	2995	481865	8	9	2.0	3427
	8.5	25	1.5	1600	0	2.2	0.5	-10	120	FKM	E121K46	4270	481000	8	8	2.0	3427
	8.5	25	1.5	1600	0	4	1.2	-10	120	FKM	E121K46	4270	486265	14	14	2.0	3427
	11	36	2.16	2500	0	0.7	0.3	-10	100	FKM	E121K45	2995	481865	8	9	2.0	3427
	11	36	2.16	2500	0	1.2	0.35	-10	120	FKM	E121K45	4270	481000	8	8	2.0	3427
11	36	2.16	2500	0	2.5	0.7	-10	120	FKM	E121K45	4270	486265	14	14	2.0	3427	

Notes:

1. With manual override

BRASS

PIPE MOUNTING

NORMALLY OPEN

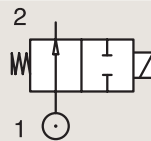

Port size	Orifice Ø	Flow factors			Operating Pressure Differential			Fluid Temp.		Seat Seal	Valve Ref.	Housing Ref.	Coil Ref.	Power		Coil Group	Dwg. No.
		Kv l/min	KV m³/h	Qn l/min	Min bar	Max(MOPD) AC bar	DC bar	Min °C	Max °C					AC W	DC W		
1/4"	2.5	3	0.18	180	0	12	12	-10	100	FKM	122K8306	2995	481865	8	9	2.0	3510
	2.5	3	0.18	180	0	12	12	-10	120	FKM	122K8306	4270	481000	8	8	2.0	3510
	2.5	3	0.18	180	0	12	12	-10	120	FKM	122K8306	4270	486265	14	14	2.0	3510



For this page	Port size	Orifice (mm)	Kv (l/min)	MOPD (bar)	Fluid Temp (°C)
From	1/4"	2.5	3	0.3	-10
To	1/2"	11	36	12	120

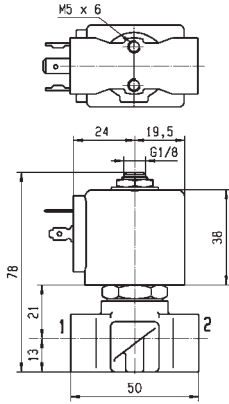

WEIGHT : 215 gr

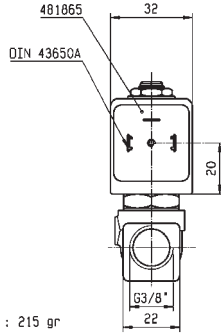

Drawing 3551

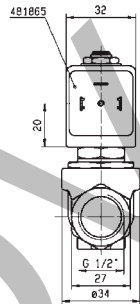
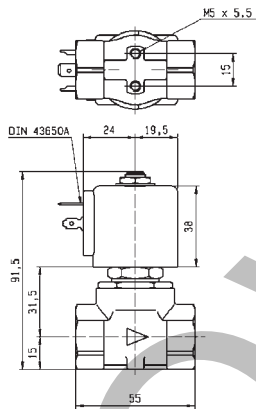

Drawing 3427

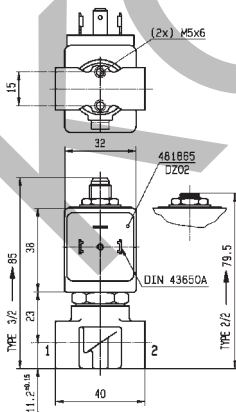

A	
61/8"	6 1/4"
1/8"-27 NPT	1/4"-18 NPT

OPTION
Manual override
121...131K...50

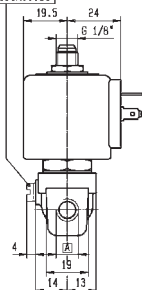

Drawing 3510

2/2

VALVES FOR WATER AND NEUTRAL LIQUIDS

DIRECT OPERATED

BRASS

PIPE MOUNTING

CONTROL BY ELECTRIC IMPULSE

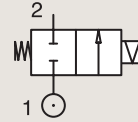

Port size	Orifice Ø	Flow factors			Operating Pressure Differential			Fluid Temp.		Seat Seal	Valve Ref.	Housing Ref.	Coil Ref.	Power		Coil Group	Dwg. No.
		Kv l/min	KV m ³ /h	Qn l/min	Min bar	Max(MOPD) AC bar	DC bar	Min °C	Max °C					AC W	DC W		
1/4"	5	11	0.66	750	0	5	-	-10	100	FKM	125K01	4269	484990	11	-	4.0	8296
	5	11	0.66	750	0	-	1.5	-10	100	FKM	125K01	4269	485400	-	13	4.0	8296



For this page	Port size	Orifice (mm)	Kv (l/min)	MOPD (bar)	Fluid Temp (°C)
From	1/4"	5	11	1.5	-10
To	1/4"	5	11	5	100

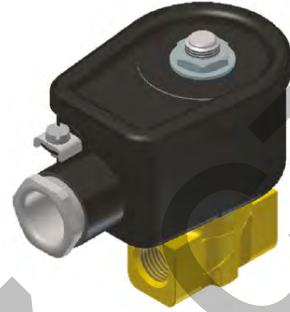
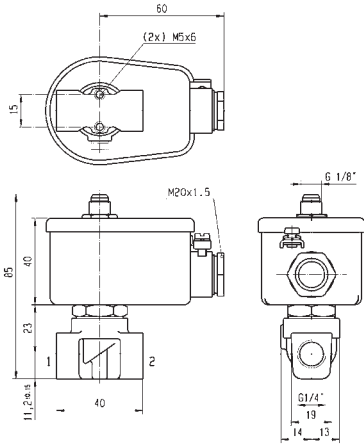

Drawing 8296

KOVALAN

2/2

VALVES FOR WATER AND NEUTRAL LIQUIDS

DIRECT OPERATED

BRASS

SUB-BASE MOUNTING

NORMALLY CLOSED

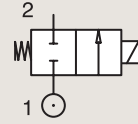

Port size	Orifice Ø		Flow factors			Operating Pressure Differential			Fluid Temp.		Seat Seal	Valve Ref.	Housing Ref.	Coil Ref.	Power		Coil Group	Dwg. No.
	mm	Kv l/min	KV m³/h	Qn l/min	Min bar	Max(MOPD) AC bar	DC bar	Min °C	Max °C	AC W					DC W			
SB	1.5	1.5	0.09	80	0	20	20	-10	100	FKM	E121F4406	2995	481865	8	9	2.0	3509	
	1.5	1.5	0.09	80	0	20	20	-10	120	FKM	E121F4406	4270	481000	8	8	2.0	3509	
	1.5	1.5	0.09	80	0	20	20	-10	120	FKM	E121F4406	4270	486265	14	14	2.0	3509	
	3	4.5	0.27	320	0	10	7	-10	100	FKM	E121F4302	2995	481865	8	9	2.0/3.0	3509	
	3	4.5	0.27	320	0	10	8.5	-10	120	FKM	E121F4302	4270	481000	8	8	2.0/3.0	3509	
	3	4.5	0.27	320	0	10	10	-10	120	FKM	E121F4302	4270	486265	14	14	2.0/3.0	3509	

2/2

VALVES FOR WATER AND NEUTRAL LIQUIDS

PILOT OPERATED

BRASS

PIPE MOUNTING

NORMALLY CLOSED

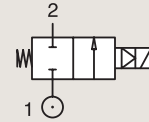

Port size	Orifice Ø	Flow factors			Operating Pressure Differential			Fluid Temp.		Seat Seal	Valve Order Number	Valve Type	Coil Type	Power		Coil Group	Dwg. No.
		Kv l/min	KV m³/h	Qn m³/h	Min bar	AC bar	DC bar	Min °C	Max °C					AC W	DC W		
3/8"	13	50	3	-	0.1	10	10	-10	140	EPDM	443778W ₁	7321BIH00	481865	8	9	2.0	028
	13	50	3	-	0.1	20	20	-10	90	NBR	443776W	7321BIN00	481865	8	9	2.0	028
	13	50	3	-	0.1	20	20	-10	90	NBR	443777W ₂	7321BIN01	481865	8	9	2.0	028
	13	50	3	-	0.1	20	20	-10	140	FKM	444492W	7321BIV00	481865	8	9	2.0	028
1/2"	13	50	3	-	0.1	10	10	-10	140	EPDM	443781W ₁	7321BAH00	481865	8	9	2.0	028
	13	50	3	-	0.1	20	20	-10	90	NBR	443779W	7321BAN00	481865	8	9	2.0	028
	13	50	3	-	0.1	20	20	-10	90	NBR	443780W ₂	7321BAN01	481865	8	9	2.0	028
	13	50	3	-	0.1	20	20	-10	140	FKM	444494W	7321BAV00	481865	8	9	2.0	028
3/4"	20	140	8.4	-	0.1	10	10	-10	140	EPDM	443785W ₁	7321BCH00	481865	8	9	2.0	057
	20	140	8.4	-	0.1	20	20	-10	90	NBR	443782W	7321BCN00	481865	8	9	2.0	057
	20	140	8.4	-	0.1	10	10	-10	90	NBR	443783W ₂	7321BCN01	481865	8	9	2.0	057
	20	140	8.4	-	0.1	20	20	-10	140	FKM	444497W	7321BCV00	481865	8	9	2.0	057
1"	25	160	9.6	-	0.1	10	10	-10	140	EPDM	443789W ₁	7321BDH00	481865	8	9	2.0	057
	25	160	9.6	-	0.1	20	20	-10	90	NBR	443786W	7321BDN00	481865	8	9	2.0	057
	25	160	9.6	-	0.1	10	10	-10	90	NBR	443787W ₂	7321BDN01	481865	8	9	2.0	057
	25	160	9.6	-	0.1	20	20	-10	140	FKM	443804W	7321BDV00	481865	8	9	2.0	057

Notes:

1. Maximum pressure for steam: 4 Bar (140°C)

2. With manual override

Important: pressure vessels included in this page are supplied with the standard 2995 housing integrated.



For this page	Port size	Orifice (mm)	Kv (l/min)	MOPD (bar)	Fluid Temp (°C)
From	3/8"	13	50	10	-10
To	1"	25	160	20	140

G	A		B		C	
NPT	mm	inch	mm	inch	mm	inch
3/8"	89	2.71	99.5	3.91	40	1.57
1/2"	72	2.83	101.5	3.99	40	1.57

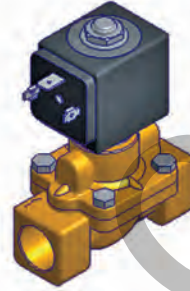
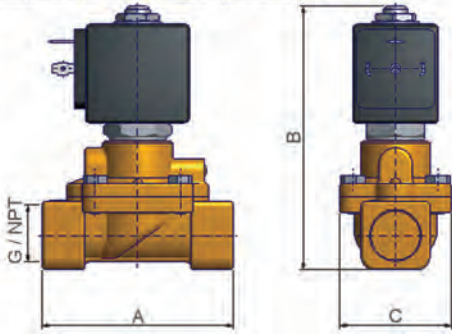

Drawing 028

G	A		B		C	
NPT	mm	inch	mm	inch	mm	inch
3/4"	100	3.93	107	4.21	65	2.55
1"	104	4.09	112.5	4.42	65	2.55

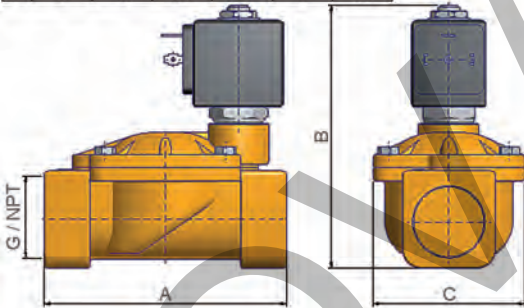

Drawing 057

2/2

VALVES FOR WATER AND NEUTRAL LIQUIDS

PILOT OPERATED

BRASS

PIPE MOUNTING

NORMALLY CLOSED

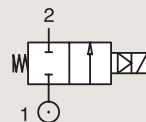

Port size	Orifice Ø	Flow factors			Operating Pressure Differential			Fluid Temp.		Seat Seal	Valve Order Number	Valve Type	Coil Type	Power		Coil Group	Dwg. No.
		Kv l/min	KV m ³ /h	Qn m ³ /h	Min bar	AC bar	DC bar	Min °C	Max °C					AC W	DC W		
1 1/4"	35	420	25.2	-	0.1	10	10	-10	140	EPDM	443793W ₁	7321BEH00	481865	8	9	2.0	058
	35	420	25.2	-	0.1	10	10	-10	90	NBR	443790W	7321BEN00	481865	8	9	2.0	058
	35	420	25.2	-	0.1	5	5	-10	90	NBR	443791W ₂	7321BEN01	481865	8	9	2.0	058
1 1/2"	40	500	30	-	0.1	10	10	-10	140	EPDM	443797W ₁	7321BFH00	481865	8	9	2.0	058
	40	500	30	-	0.1	10	10	-10	90	NBR	443794W	7321BFN00	481865	8	9	2.0	058
	40	500	30	-	0.1	5	5	-10	90	NBR	443795W ₂	7321BFN01	481865	8	9	2.0	058
2"	50	620	37.2	-	0.1	10	10	-10	140	EPDM	443801W ₁	7321BGH00	481865	8	9	2.0	058
	50	620	37.2	-	0.1	10	10	-10	90	NBR	443798W	7321BGN00	481865	8	9	2.0	058
	50	620	37.2	-	0.1	5	5	-10	90	NBR	443799W ₂	7321BGN01	481865	8	9	2.0	058

Notes:

1. Maximum pressure for steam: 4 Bar (140°C)

2. With manual override

Important: pressure vessels included in this page are supplied with the standard 2995 housing integrated.



For this page	Port size	Orifice (mm)	Kv (l/min)	MOPD (bar)	Fluid Temp (°C)
From	1 1/4"	35	420	5	-10
To	2"	50	620	10	140

NPT	A		B		C	
	mm	inch	mm	inch	mm	inch
1-1/4"	145	5.70	134	5.27	102	4.01
1-1/2"	145	5.70	134	5.27	102	4.01
2"	173	6.81	148	5.82	118	4.64

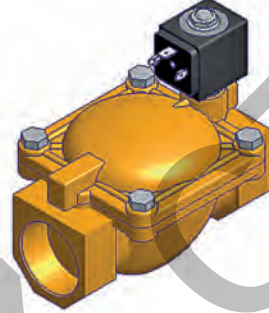
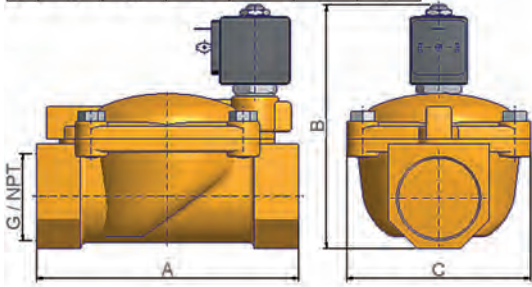

Drawing 058

KOLVAN

2/2

VALVES FOR WATER AND NEUTRAL LIQUIDS

PILOT OPERATED

BRASS

PIPE MOUNTING

NORMALLY CLOSED

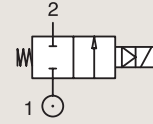

Port size (BSP)	Orifice Ø mm	Flow factors			Operating Pressure Differential Max(MOPD)			Fluid Temp.		Seat Seal	Valve Ref.	Housing Ref.	Coil Ref.	Power		Coil Group	Dwg. No.
		Kv l/min	KV m³/h	Qn m³/h	Min bar	AC bar	DC bar	Min °C	Max °C					AC W	DC W		
		1.68	1800	0.2	10	3	-10	100	NBR					E321K10	2995		
1/4"	11	28	1.68	1800	0.2	10	3	-10	100	NBR	E321K10	2995	481865	8	9	2.0	3429
	11	28	1.68	1800	0.2	10	4	-10	100	NBR	E321K10	4270	481000	8	8	2.0	3429
	12	30	1.8	2150	0.3	10	10	-10	100	NBR	321K31	8993	481180	4	5	1.1	7093
	12	30	1.8	2150	0.3	10	7	-10	75	NBR	321K31	8993	488980	2	2.5	1.1	7093
	12	32	1.92	2150	0.3	12	12	-10	100	FKM	321K4106	2995	481865	8	9	2.1/3.0	7094
	12	32	1.92	2150	0.3	12	12	-10	120	FKM	321K4106	4270	481000	8	8	2.1/3.0	7094
3/8"	11	36	2.16	2500	0.2	10	4	-10	100	NBR	E321K13	4270	481000	8	8	2.0	3429
	11	36	2.16	2500	0.2	10	10	-10	100	NBR	E321K13	4270	486265	14	14	2.0	3429
	12	45	2.7	3050	0.3	10	10	-10	100	NBR	321K33	8993	481180	4	5	1.1	7093
	12	45	2.7	3050	0.3	10	7	-10	75	NBR	321K33	8993	488980	2	2.5	1.1	7093
	12	45	2.7	3050	0.3	12	12	-10	100	FKM	321K4306	2995	481865	8	9	2.1/3.0	7094
	12	45	2.7	3050	0.3	12	12	-10	120	FKM	321K4306	4270	481000	8	8	2.1/3.0	7094



For this page	Port size	Orifice (mm)	Kv (l/min)	MOPD (bar)	Fluid Temp (°C)
From	1/4"	11	28	3	-10
To	3/8"	12	45	12	120

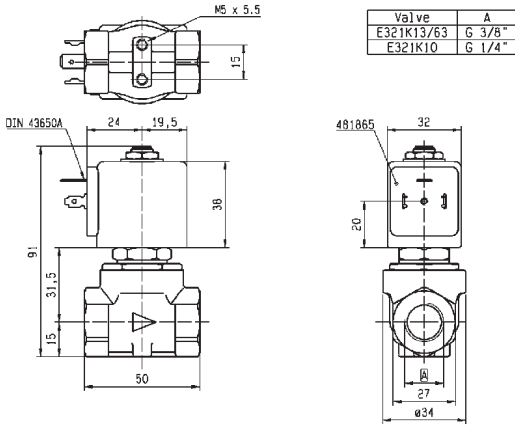

Drawing 3429

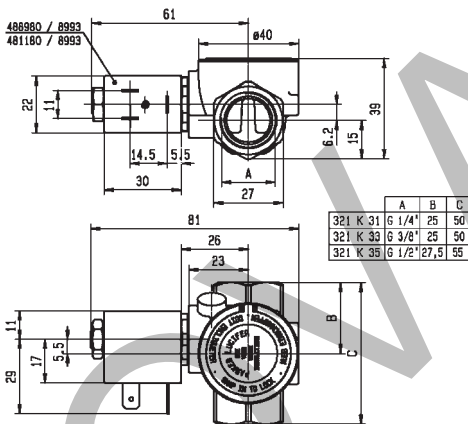

Drawing 7093

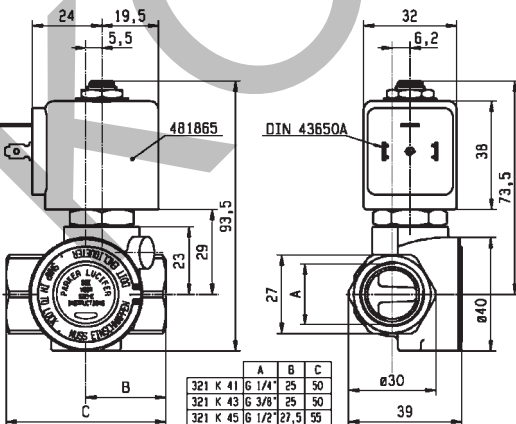

Drawing 7094

2/2

VALVES FOR WATER AND NEUTRAL LIQUIDS

PILOT OPERATED

BRASS

PIPE MOUNTING

NORMALLY CLOSED

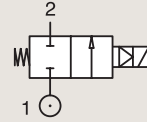

Port size (BSP)	Orifice Ø mm	Flow factors			Operating Pressure Differential Max(MOPD)			Fluid Temp.		Seat Seal	Valve Ref.	Housing Ref.	Coil Ref.	Power		Coil Group	Dwg. No.
		Kv l/min	KV m³/h	Qn m³/h	Min bar	AC bar	DC bar	Min °C	Max °C					AC W	DC W		
		2.16	2500	0.2	10	3	-10	100	NBR					E321K15	2995		
1/2"	11	36	2.16	2500	0.2	10	10	-10	120	NBR	E321K15	4270	486265	14	14	2.0	3427
	11	36	2.16	2500	0.2	10	3	-10	100	FKM	E321K25	2995	481865	8	9	2.0	3427
	11	36	2.16	2500	0.2	4	4	-10	65	FKM	E321K25	-	492070	9	8	2.0	3427
	12	50	3	3400	0.3	10	10	-10	100	NBR	321K35	8993	481180	4	5	1.1	7093
	12	50	3	3400	0.3	10	7	-10	75	NBR	321K35	8993	488980	2	2.5	1.1	7093
	12	50	3	3400	0.3	12	12	-10	100	FKM	321K4506	2995	481865	8	9	2.1/3.0	7094
	12	50	3	3400	0.3	12	12	-10	120	FKM	321K4506	4270	481000	8	8	2.1/3.0	7094
	12	50	3	3400	0.3	12	12	-10	100	FKM	321K4556	2995	481865	8	9	2.1/3.0	7094
	12	50	3	3400	0.3	12	12	-10	120	FKM	321K4556	4270	481000	8	8	2.1/3.0	7094

Notes:

1. With manual override



For this page	Port size	Orifice (mm)	Kv (l/min)	MOPD (bar)	Fluid Temp (°C)
From	1/2"	11	36	3	-10
To	1/2"	12	50	12	120

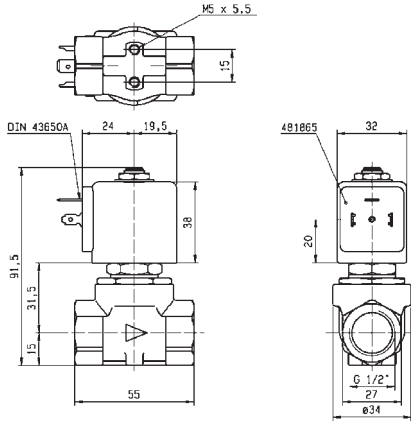

Drawing 3427

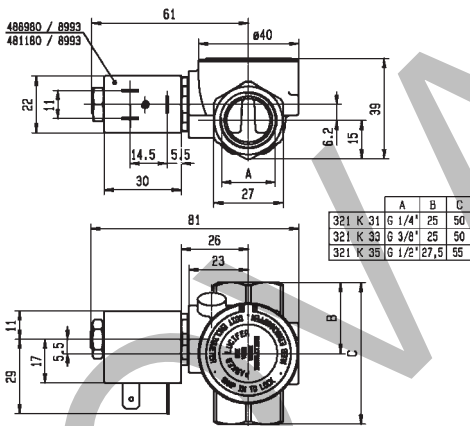

Drawing 7093

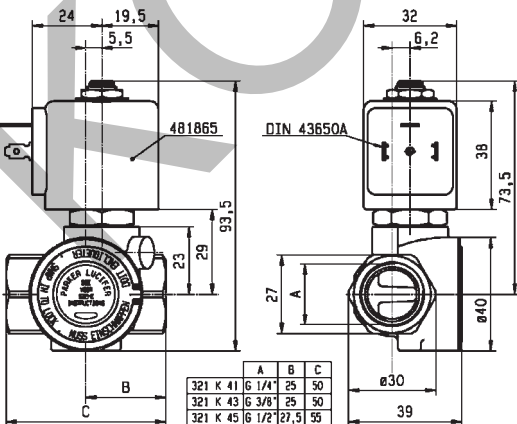

Drawing 7094

2/2

VALVES FOR WATER AND NEUTRAL LIQUIDS

PILOT OPERATED

BRASS

PIPE MOUNTING

NORMALLY CLOSED

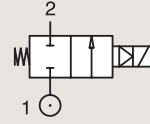

Port size (BSP)	Orifice Ø			Flow factors			Operating Pressure Differential			Fluid Temp.		Seat Seal	Valve Ref.	Housing Ref.	Coil Ref.	Power		Coil Group	Dwg. No.
	mm	Kv l/min	KV m³/h	Qn m³/h	Min bar	Max(MOPD)		Min °C	Max °C	AC W	DC W								
						AC bar	DC bar												
3/4"	18	100	6	9400	0.3	10	10	-10	100	NBR	321K36	8993	481180	4	5	1.1	7097		
	18	100	6	9400	0.3	10	7	-10	75	NBR	321K36	8993	488980	2	2.5	1.1	7097		
	18	100	6	9400	0.3	12	12	-10	100	FKM	321K4606	2995	481865	8	9	2.1/3.0	7099		
	18	100	6	9400	0.3	12	12	-10	120	FKM	321K4606	4270	481000	8	8	2.1/3.0	7099		
	18	100	6	9400	0.3	12	12	-10	100	FKM	321K4656 ₁	2995	481865	8	9	2.1/3.0	7099		
	18	100	6	9400	0.3	12	12	-10	120	FKM	321K4656 ₁	4270	481000	8	8	2.1/3.0	7099		
	20	135	8.1	9500	0.3	16	16	-10	100	NBR	E321G36	2995	481865	8	9	2.0	3442		
	20	135	8.1	9500	0.3	16	16	-10	100	NBR	E321G36	4270	481000	8	8	2.0	3442		

Notes:

1. With manual override



For this page	Port size	Orifice (mm)	Kv (l/min)	MOPD (bar)	Fluid Temp (°C)
From	3/4"	18	100	7	-10
To	3/4"	20	135	16	120

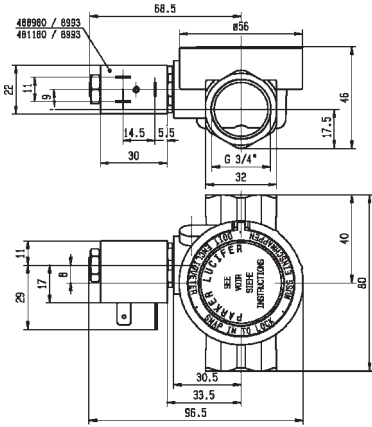

Drawing 7097

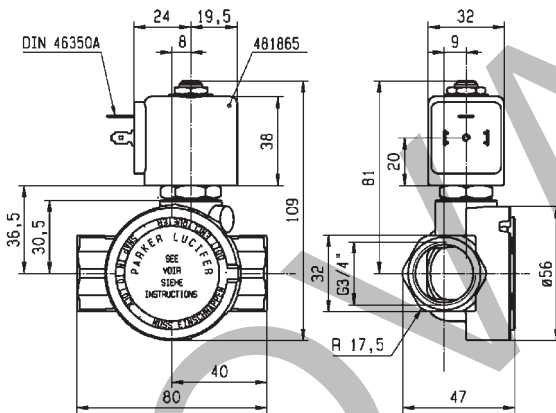

Drawing 7099

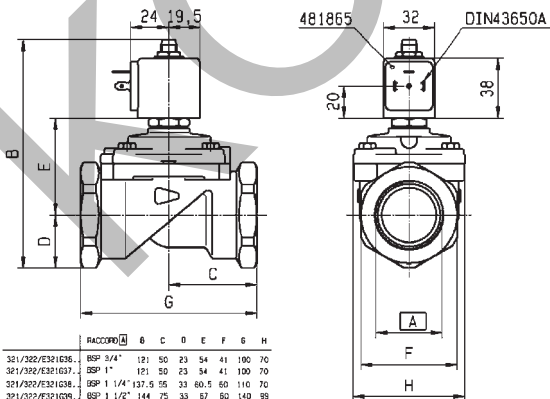

Drawing 3442

RACCORD	A	B	C	D	E	F	G	H
321/232/E321G38	BSP 3/4"	121	50	23	54	41	100	70
321/332/E331G37	OSP 1"	121	50	23	54	41	100	70
321/332/E331G38	OSP 1 1/4"	137	55	33	60,5	60	110	70
321/332/E331G39	BSP 1 1/2"	144	75	33	87	60	140	99
321G2956/G2967	UNF 1 7/8"	144	75	33	87	60	140	99
U321/A322G40...	BSP 2"	158,5	80	41,5	73	75	150	99

2/2

VALVES FOR WATER AND NEUTRAL LIQUIDS

PILOT OPERATED

BRASS

PIPE MOUNTING

NORMALLY CLOSED

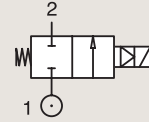

Port size (BSP)	Orifice Ø mm	Flow factors			Operating Pressure Differential Max(MOPD)			Fluid Temp.		Seat Seal	Valve Ref.	Housing Ref.	Coil Ref.	Power		Coil Group	Dwg. No.
		Kv l/min	KV m³/h	Qn m³/h	Min bar	AC bar	DC bar	Min °C	Max °C					AC W	DC W		
		10150	10150	10150	0.3	10	10	-10	100					4	5		
1"	18	110	6.6	10150	0.3	10	10	-10	100	NBR	321K37	8993	481180	4	5	1.1	7098
	18	110	6.6	10150	0.3	10	7	-10	75	NBR	321K37	8993	488980	2	2.5	1.1	7098
	18	110	6.6	10150	0.3	12	12	-10	100	FKM	321K4706	2995	481865	8	9	2.1/3.0	7100
	18	110	6.6	10150	0.3	12	12	-10	120	FKM	321K4706	4270	481000	8	8	2.1/3.0	7100
	18	110	6.6	10150	0.3	12	12	-10	100	FKM	321K4756 ₂	2995	481865	8	9	2.1/3.0	7100
	18	110	6.6	10150	0.3	12	12	-10	120	FKM	321K4756 ₂	4270	481000	8	8	2.1/3.0	7100
1 1/4"	25	180	10.8	14000	0.3	16	16	-10	100	NBR	E321G37	2995	481865	8	9	2.0	3442
	25	180	10.8	14000	0.3	16	16	-10	100	NBR	E321G37	4270	481000	8	8	2.0	3442
1 1/4"	28	270	16.2	18000	0.3	16	16	-10	100	NBR	E321G38	2995	481865	8	9	2.0	3442
	28	270	16.2	18000	0.3	16	16	-10	100	NBR	E321G38	4270	481000	8	8	2.0	3442
1 1/2"	40	420	25.2	31500	0.3	16	7	-10	100	NBR	E321G39 ₁	2995	481865	8	9	2.0	3442
	40	420	25.2	31500	0.3	16	8.5	-10	100	NBR	E321G39 ₁	4270	481000	8	8	2.0	3442
2"	40	420	25.2	31500	0.3	16	16	-10	100	NBR	E321G39 ₁	4270	486265	14	14	2.0	3442
	40	540	32.4	40000	0.3	16	7	-10	100	NBR	E321G40 ₁	2995	481865	8	9	2.0	3442
	40	540	32.4	40000	0.3	16	8.5	-10	100	NBR	E321G40 ₁	4270	481000	8	8	2.0	3442
2"	40	540	32.4	40000	0.3	16	16	-10	100	NBR	E321G40 ₁	4270	486265	14	14	2.0	3442

Notes:

1. Pilot seat disc in synthetic Ruby
2. With manual override



For this page	Port size	Orifice (mm)	Kv (l/min)	MOPD (bar)	Fluid Temp (°C)
From	1"	18	110	7	-10
To	2"	40	540	16	120

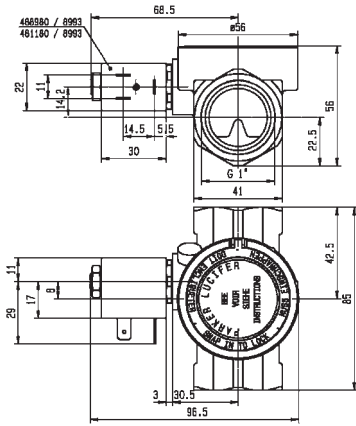

Drawing 7098

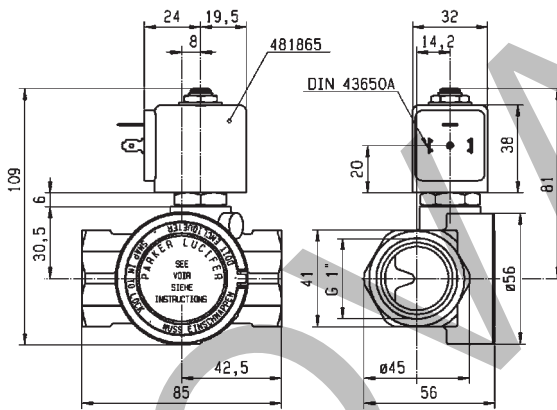

Drawing 7100

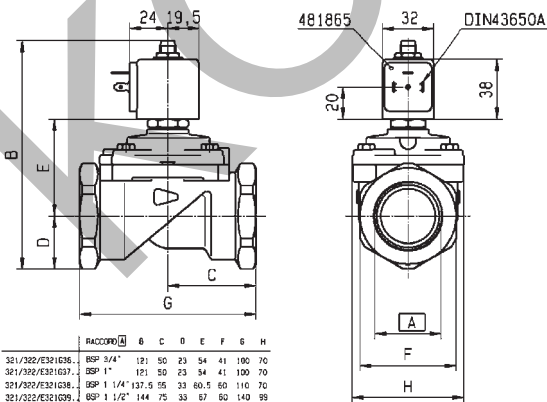

Drawing 3442

	RACCORD	6	C	D	E	F	G	H
321/232/E321636	BSP 3/4"	121	50	23	54	41	100	70
321/332/E331037	BSP 1"	121	50	23	54	41	100	70
321/332/E331038	BSP 1 1/4"	137	55	33	60,5	60	110	70
321/332/E331039	BSP 1 1/2"	144	75	33	67	60	140	59
321/396/G3967	UNF 1 7/8"	144	75	33	67	60	140	59
U321/A322640...	BSP 2"	158,5	80	41,5	73	75	150	99

2/2

VALVES FOR WATER AND NEUTRAL LIQUIDS

PILOT OPERATED

BRASS

PIPE MOUNTING

NORMALLY OPEN

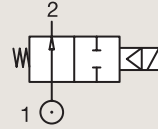

Port size	Orifice Ø	Flow factors			Operating Pressure Differential		Fluid Temp.		Seat Seal	Valve Order Number	Valve Type	Coil Type	Power		Coil Group	Dwg. No.	
		Kv l/min	KV m³/h	Qn m³/h	Min bar	Max(MOPD) DC bar	Min °C	Max °C					AC W	DC W			
3/8"	13	50	3	-	0.1	10	10	-10	140	EPDM	444600W	7322BIH00	481865	8	9	2.0	060
	13	50	3	-	0.1	20	20	-10	90	NBR	443805W	7322BIN00	481865	8	9	2.0	060
	13	50	3	-	0.1	20	20	-10	140	FKM	444499W	7322BIV00	481865	8	9	2.0	060
1/2"	13	50	3	-	0.1	10	10	-10	140	EPDM	444601W	7322BAH00	481865	8	9	2.0	060
	13	50	3	-	0.1	20	20	-10	90	NBR	443806W	7322BAN00	481865	8	9	2.0	060
	13	50	3	-	0.1	20	20	-10	140	FKM	444500W	7322BAV00	481865	8	9	2.0	060
3/4"	20	140	8.4	-	0.1	10	10	-10	140	EPDM	444602W	7322BCH00	481865	8	9	2.0	061
	20	140	8.4	-	0.1	20	20	-10	90	NBR	443807W	7322BCN00	481865	8	9	2.0	061
	20	140	8.4	-	0.1	20	20	-10	140	FKM	444501W	7322BCV00	481865	8	9	2.0	061
1"	25	160	9.6	-	0.1	10	10	-10	140	EPDM	444603W	7322BDH00	481865	8	9	2.0	061
	25	160	9.6	-	0.1	20	20	-10	90	NBR	443808W	7322BDN00	481865	8	9	2.0	061
	25	160	9.6	-	0.1	20	20	-10	140	FKM	444502W	7322BDV00	481865	8	9	2.0	061
1 1/4"	35	420	25.2	-	0.1	10	10	-10	140	EPDM	444576W	7322BEH00	481865	8	9	2.0	062
	35	420	25.2	-	0.1	10	10	-10	90	NBR	443809W	7322BEN00	481865	8	9	2.0	062
1 1/2"	40	500	30	-	0.1	10	10	-10	140	EPDM	444604W	7322BFH00	481865	8	9	2.0	062
	40	500	30	-	0.1	10	10	-10	90	NBR	443810W	7322BFN00	481865	8	9	2.0	062
2"	50	620	37.2	-	0.1	10	10	-10	140	EPDM	444605W	7322BGH00	481865	8	9	2.0	062
	50	620	37.2	-	0.1	10	10	-10	90	NBR	443811W	7322BGN00	481865	8	9	2.0	062
2 1/2"	65	1100	66	-	0.2	10	10	-10	90	NBR	444513W	7322BLN06	481865	8	9	2.0	063
3"	75	1334	80	-	0.2	10	10	-10	90	NBR	444503W	7322BMN06	481865	8	9	2.0	063

Important: pressure vessels included in this page are supplied with the standard 2995 housing integrated.

G NPT	A		B		C	
	mm	inch	mm	inch	mm	inch
1-1/4"	145	5.70	144.5	5.68	102	4.01
1-1/2"	145	--	154	--	102	--
2"	173	--	148	--	118	--

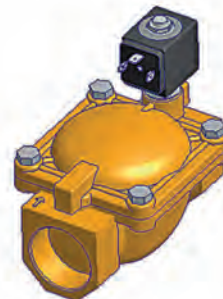
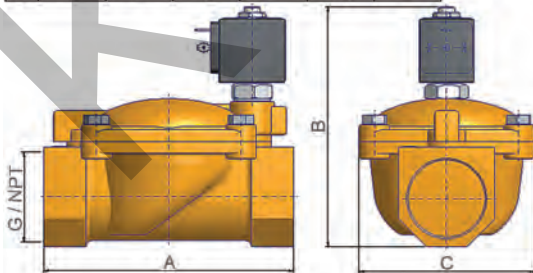

Drawing 062



For this page	Port size	Orifice (mm)	Kv (l/min)	MOPD (bar)	Fluid Temp (°C)
From	3/8"	13	50	10	-10
To	3"	75	1334	20	140

G	A		B		C	
	mm	inch	mm	inch	mm	inch
3/8"	89	2.71	110	4.33	40	1.57
1/2"	72	2.83	112	4.41	40	1.57

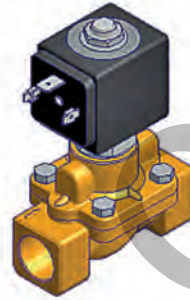
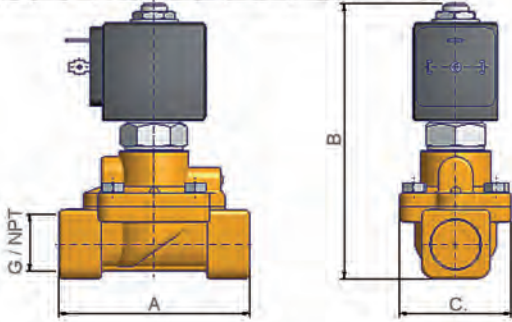

Drawing 060

G	A		B		C	
	mm	inch	mm	inch	mm	inch
3/4"	100	3.83	117.5	4.62	65	2.55
1"	104	4.09	123	4.84	65	2.55

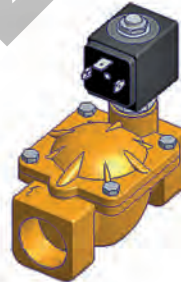
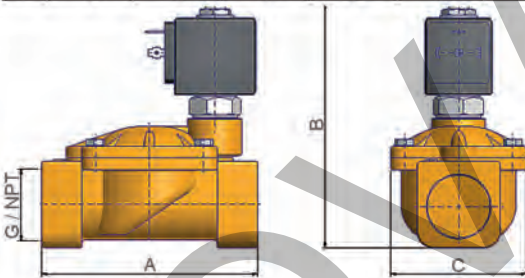

Drawing 061

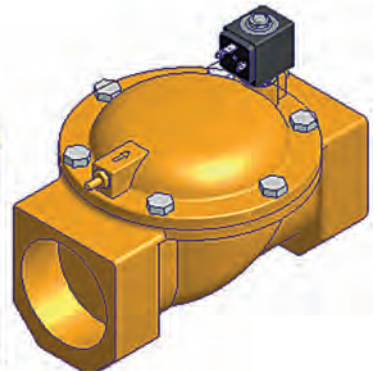
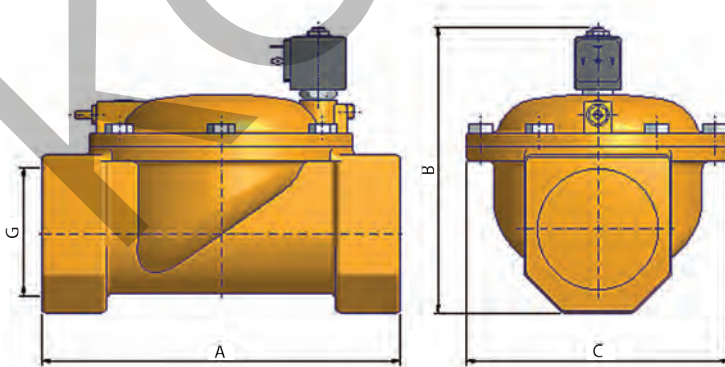

Drawing 063

2/2

VALVES FOR WATER AND NEUTRAL LIQUIDS

PILOT OPERATED

BRASS

PIPE MOUNTING

NORMALLY OPEN

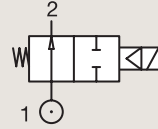

Port size	Orifice Ø	Flow factors			Operating Pressure Differential			Fluid Temp.		Seat Seal	Valve Ref.	Housing Ref.	Coil Ref.	Power		Coil Group	Dwg. No.
		Kv l/min	KV m³/h	Qn l/min	Min bar	Max(MOPD) AC bar	DC bar	Min °C	Max °C					AC W	DC W		
1/4"	12	32	1.92	2150	0.3	12	12	-10	100	FKM	322K4106	2995	481865	8	9	2.1	7094
	12	32	1.92	2150	0.3	12	12	-10	120	FKM	322K4106	4270	481000	8	8	2.1	7094
3/8"	12	45	2.7	3050	0.3	12	12	-10	100	FKM	322K4306	2995	481865	8	9	2.1	7094
	12	45	2.7	3050	0.3	12	12	-10	120	FKM	322K4306	4270	481000	8	8	2.1	7094
1/2"	12	50	3	3400	0.3	12	12	-10	100	FKM	322K4506	2995	481865	8	9	2.1	7094
	12	50	3	3400	0.3	12	12	-10	120	FKM	322K4506	4270	481000	8	8	2.1	7094
	15	60	3.6	3890	0.3	15	15	-10	100	NBR	322G75	2995	481865	8	9	2.1	3522
3/4"	15	60	3.6	3890	0.3	15	15	-10	100	NBR	322G75	4270	481000	8	8	2.1	3522
	18	100	6	9400	0.3	12	12	-10	100	FKM	322K4606	2995	481865	8	9	2.1	7099
	18	100	6	9400	0.3	12	12	-10	120	FKM	322K4606	4270	481000	8	8	2.1	7099
	20	135	8.1	9500	0.3	16	16	-10	100	NBR	322G36	2995	481865	8	9	2.1	3442
	20	135	8.1	9500	0.3	16	16	-10	100	NBR	322G36	4270	481000	8	8	2.1	3442

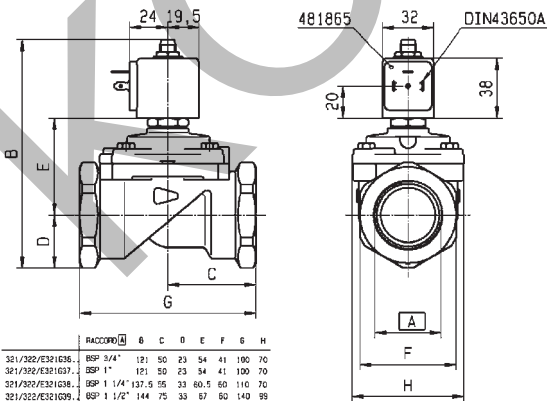

Part No.	Port Size	Orifice	Flow Factor	Operating Pressure	Fluid Temp. Range	Seat Seal	Valve Ref.	Housing Ref.	Coil Ref.	Power	Coil Group	Dwg. No.
321/322/E321G38..	BSP 3/4"	12	50	23	54	41	100	70				
321/322/E321G37..	OSP 1"	15	50	23	54	41	100	70				
321/322/E321G36..	OSP 1 1/4"	137.5	55	33	60.5	60	110	70				
321/322/E321G29..	BSP 1 1/2"	144	75	33	67	60	140	50				
321G2956/G2967	ENF 1 7/8"	144	75	33	67	60	140	50				
L321A/G22G40..	BSP 2"	158.5	80	41.5	73	75	150	99				

Drawing 3442



For this page	Port size	Orifice (mm)	Kv (l/min)	MOPD (bar)	Fluid Temp (°C)
From	1/4"	12	32	12	-10
To	3/4"	20	135	16	120

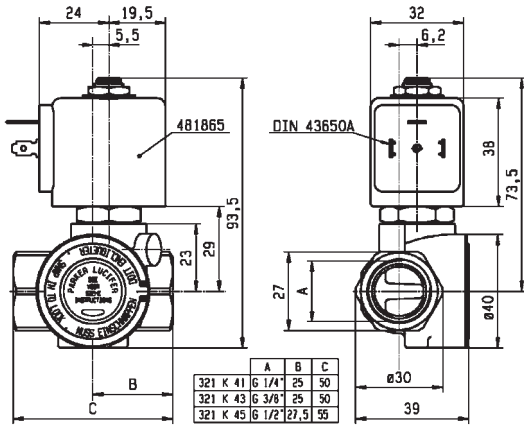

Drawing 7094

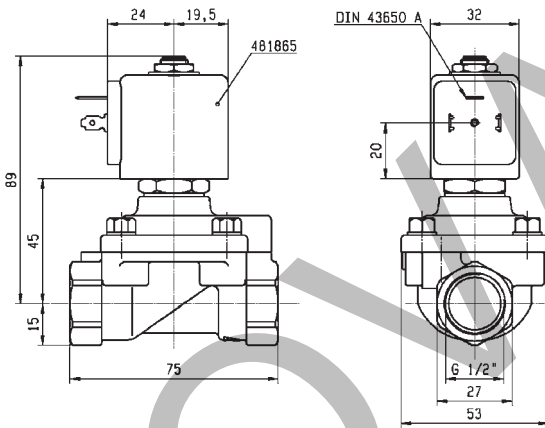

Drawing 3522

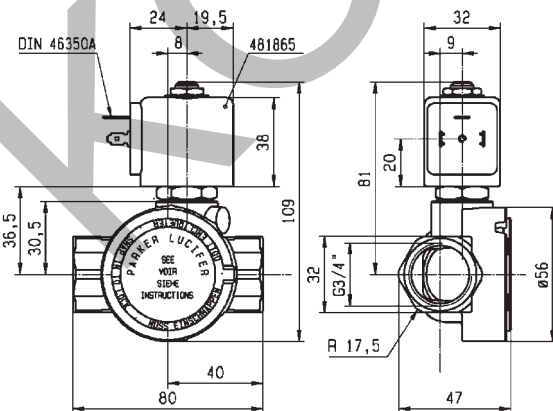

Drawing 7099

2/2

VALVES FOR WATER AND NEUTRAL LIQUIDS

PILOT OPERATED

BRASS

PIPE MOUNTING

NORMALLY OPEN

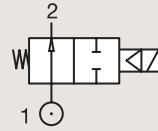

Port size	Orifice Ø	Flow factors			Operating Pressure Differential			Fluid Temp.		Seat Seal	Valve Ref.	Housing Ref.	Coil Ref.	Power		Coil Group	Dwg. No.
		Kv l/min	KV m³/h	Qn l/min	Min bar	Max(MOPD) AC bar	DC bar	Min °C	Max °C					AC W	DC W		
1"	18	110	6.6	10150	0.3	12	12	-10	100	FKM	322K4706	2995	481865	8	9	2.0	7100
	18	110	6.6	10150	0.3	12	12	-10	120	FKM	322K4706	4270	481000	8	8	2.0	7100
	25	180	10.8	14000	0.3	16	16	-10	100	NBR	322G37	2995	481865	8	9	2.1	3442
	25	180	10.8	14000	0.3	16	16	-10	100	NBR	322G37	4270	481000	8	8	2.1	3442
1 1/2"	40	420	25.2	31500	0.3	12	12	-10	100	NBR	322G39	2995	481865	8	9	2.1	3442
	40	420	25.2	31500	0.3	12	12	-10	100	NBR	322G39	4270	481000	8	8	2.1	3442

BRASS

SUB-BASE MOUNTING

NORMALLY CLOSED

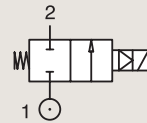

Port size	Orifice Ø	Flow factors			Operating Pressure Differential			Fluid Temp.		Seat Seal	Valve Ref.	Housing Ref.	Coil Ref.	Power		Coil Group	Dwg. No.
		Kv l/min	KV m³/h	Qn l/min	Min bar	Max(MOPD) AC bar	DC bar	Min °C	Max °C					AC W	DC W		
SB	14	45	2.7	2100	0.3	40	25	-10	100	NBR	E321F32	2995	481865	8	9	2.0	3520
	14	45	2.7	2100	0.3	40	30	-10	100	NBR	E321F32	4270	481000	8	8	2.0	3520
	14	45	2.7	2100	0.3	40	40	-10	100	NBR	E321F32	4270	486265	14	14	2.0	3520

Notes:

1. Pilot seat disc in synthetic Ruby



For this page	Port size	Orifice (mm)	Kv (l/min)	MOPD (bar)	Fluid Temp (°C)
From	14 mm	14	45	12	-10
To	1 1/2"	40	420	40	120

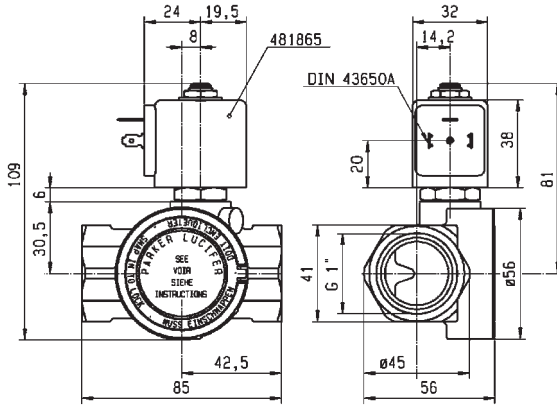

Drawing 7100

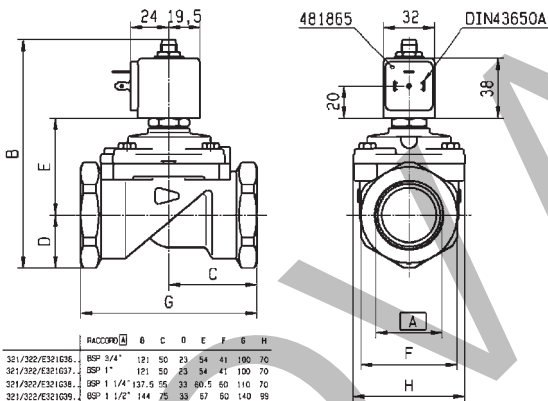

Drawing 3442

RACCORD	6	C	D	E	F	G	H
321/322/E321G36	BSP 3/4"	121	50	21	54	41	100 70
321/322/E321G37	BSP 1"	121	50	23	54	41	100 70
321/320/E321G38	BSP 1 1/4"	137.5	55	33	60.5	60	110 70
321/322/E321G39	BSP 1 1/2"	144	75	33	67	80	140 99
321/320/E321G40	NPT 1 1/2"	144	75	33	67	80	140 99
U321A/U320A40..	BSP 2"	156.5	80	41.5	73	75	150 99

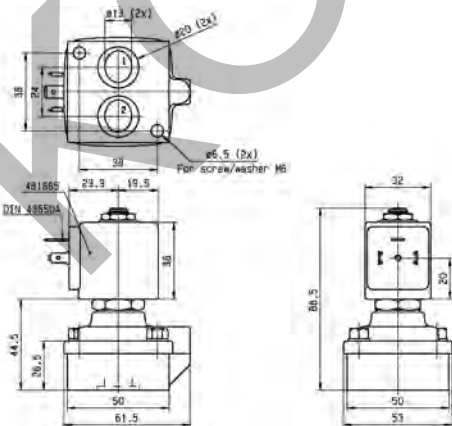

Drawing 3520

2 WAY VALVES

NOTES

Handwritten note: KOVAVZ.CZ

ANTI WATER HAMMER VALVES



2/2

Actuation	Body	Function	Port Size	Orifice (mm)	Flow Factor Kv(l/min)	MOPD (bar)	Max Fluid Temp. (°C)	Page Parker Valves	
Magnalift Pilot Operated	Brass/Pipe Mounting	Normally Closed	1"	15 to 25	170	10	140	90	
			1/4"	12	32	12	120	94	
			3/8"	12	45	12	120	94	
			1/2"	12	50	12	120	94	
			3/4"	18 to 20	135	16	120	94	
			1"	18 to 25	180	16	120	92 and 96	
			1 1/4"	28 to 35	420	16	100	92 and 96	
			1 1/2"	40	500	16	100	92 and 96	
			2"	40 to 50	620	16	100	92 and 96	
	Normally Open	Brass/Pipe Mounting	Normally Open	2 1/2"	65	1100	10	90	92
				3"	75	1334	10	90	92
				3/4"	20	135	16	100	98
				1"	25	180	16	100	98
				1 1/4"	28	270	16	100	98
				1 1/2"	40	425	12	100	98
				2"	40	540	12	100	98

KON

2/2

ANTI WATER HAMMER VALVES

MAGNALIFT



Commercial Equipment

BRASS PIPE MOUNTING

NORMALLY CLOSED

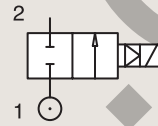

Port size	Orifice Ø	Flow factors			Operating Pressure Differential			Fluid Temp.		Seat Seal	Valve Ref.	Housing Ref.	Coil Ref.	Power		Coil Group	Dwg. No.
		Kv l/min	KV m³/h	Qn l/min	Min bar	Max(MOPD) AC bar	DC bar	Min °C	Max °C					AC W	DC W		
1"	15	80	4.8	6000	0	-	10	-10	100	NBR	221G1731 ₁₂	2995	481865	-	9	2.1	3445
	15	80	4.8	6000	0	10	10	-10	65	NBR	221G1731 ₁₂	-	492070	9	8	2.1	3445
	15	80	4.8	6000	0	10	10	-10	75	NBR	221G1731 ₁₂	-	492190	11	9	2.1	3445
	25	160	9.6	-	0	10	-	0	100	EPDM	221G2103	2995	481865	8	-	2.0	3448
	25	160	9.6	-	0	10	-	0	120	EPDM	221G2103	4270	481000	8	-	2.0	3448
	25	160	9.6	-	0	10	10	0	120	EPDM	221G2103	4270	486265	14	14	2.0	3448
	25	160	9.6	-	0	4	4	0	140	EPDM	221G2103	2995	492425	14	14	2.0	3448
	25	170	10.2	14000	0	-	10	-25	100	NBR	221G2131 ₁₂	2995	481865	-	9	2.1	3448
	25	170	10.2	14000	0	10	10	-25	40	NBR	221G2131 ₁₂	-	492070	9	8	2.1	3448
	25	170	10.2	14000	0	10	10	-25	40	NBR	221G2131 ₁₂	-	492190	11	9	2.1	3448

Notes:

- 1.Valves with model number ending in 30 or 31 are only compatible with explosion proof electrical parts shown, or with group 2.1 coils only in DC voltage.
- 2.With 4 position selector for controlled closure rate



For this page	Port size	Orifice (mm)	Kv (l/min)	MOPD (bar)	Fluid Temp (°C)
From	1"	15	80	4	-25
To	1"	25	170	10	140

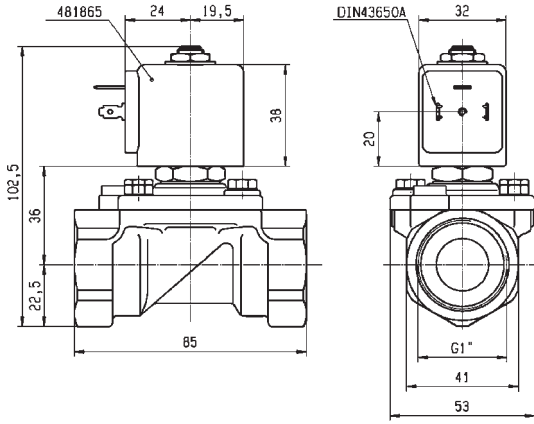

Drawing 3445

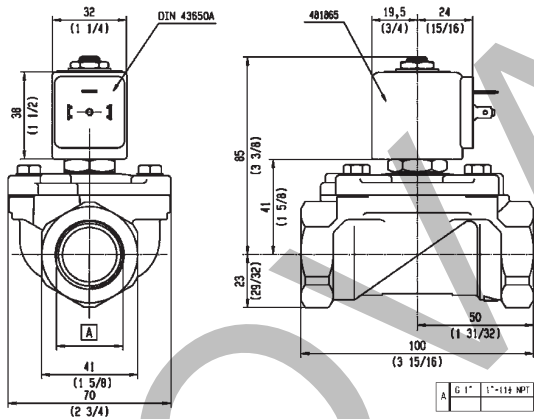

Drawing 3448

2/2

ANTI WATER HAMMER VALVES

PILOT OPERATED

BRASS

PIPE MOUNTING

NORMALLY CLOSED

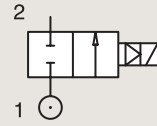

Port size	Orifice Ø	Flow factors			Operating Pressure Differential			Fluid Temp.		Seat Seal	Valve Order Number	Valve Type	Coil Type	Power		Coil Group	Dwg. No.
		Kv l/min	KV m ³ /h	Qn m ³ /h	Min bar	Max(MOPD) AC bar	DC bar	Min °C	Max °C					AC W	DC W		
3/4"	20	140	8.4	-	0.1	10	10	-10	90	NBR	443784W	7321BCN02	481865	8	9	2.0	057
1"	25	160	9.6	-	0.1	10	10	-10	90	NBR	443788W	7321BDN02	481865	8	9	2.0	057
1 1/4"	35	420	25.2	-	0.1	5	5	-10	90	NBR	443792W	7321BEN02	481865	8	9	2.0	058
1 1/2"	40	500	30	-	0.1	5	5	-10	90	NBR	443796W	7321BFN02	481865	8	9	2.0	058
2"	50	620	37.2	-	0.1	5	5	-10	90	NBR	443800W	7321BGN02	481865	8	9	2.0	058
2 1/2"	65	1100	66	-	0.2	10	10	-10	90	NBR	443802W	7321BLN02	481865	8	9	2.0	059
3"	75	1334	80	-	0.2	10	10	-10	90	NBR	443803W	7321BMN02	481865	8	9	2.0	059

Notes:

1. With manual override

Important: pressure vessels included in this page are supplied with the standard 2995 housing integrated.



For this page	Port size	Orifice (mm)	Kv (l/min)	MOPD (bar)	Fluid Temp (°C)
From	3/4"	20	140	5	-10
To	3"	75	1334	10	90

G / NPT	A		B		C	
	mm	inch	mm	inch	mm	inch
3/4"	100	3.83	107	4.21	65	2.55
1"	104	4.09	112.5	4.42	65	2.55

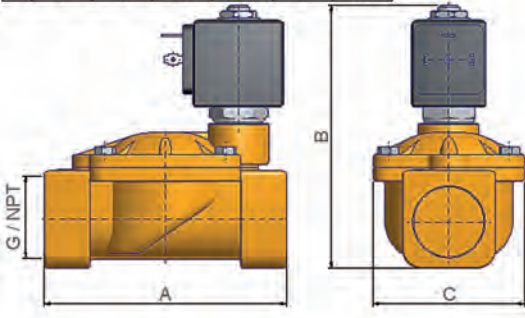

Drawing 057

G / NPT	A		B		C	
	mm	inch	mm	inch	mm	inch
1-1/4"	145	5.70	134	5.27	102	4.01
1-1/2"	145	5.70	134	5.27	102	4.01
2"	173	6.81	148	5.82	118	4.64

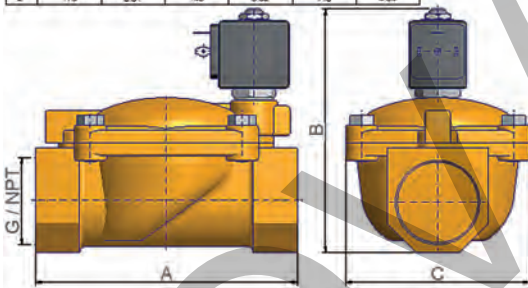

Drawing 058

G	A		B		C	
	mm	inch	mm	inch	mm	inch
2-1/2"	245	---	195	---	184	---
3"	250	---	195	---	184	---

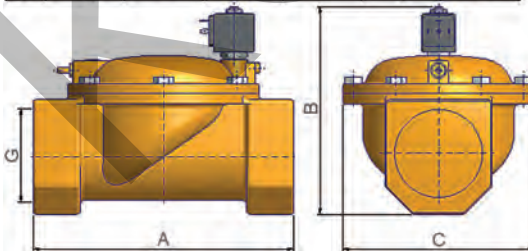

Drawing 059

2/2

ANTI WATER HAMMER VALVES

PILOT OPERATED

BRASS

PIPE MOUNTING

NORMALLY CLOSED

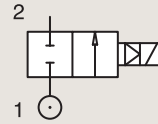

Port size	Orifice Ø	Flow factors			Operating Pressure Differential			Fluid Temp.		Seat Seal	Valve Ref.	Housing Ref.	Coil Ref.	Power		Coil Group	Dwg. No.
		Kv l/min	KV m ³ /h	Qn l/min	Min bar	AC bar	DC bar	Min °C	Max °C					AC W	DC W		
1/4"	12	32	1.92	2150	0.3	12	12	-10	100	FKM	321K4106	2995	481865	8	9	2.1/3.0	7094
	12	32	1.92	2150	0.3	12	12	-10	120	FKM	321K4106	4270	481000	8	8	2.1/3.0	7094
3/8"	12	45	2.7	3050	0.3	12	12	-10	100	FKM	321K4306	2995	481865	8	9	2.1/3.0	7094
	12	45	2.7	3050	0.3	12	12	-10	120	FKM	321K4306	4270	481000	8	8	2.1/3.0	7094
1/2"	12	50	3	3400	0.3	12	12	-10	100	FKM	321K4506	2995	481865	8	9	2.1/3.0	7094
	12	50	3	3400	0.3	12	12	-10	120	FKM	321K4506	4270	481000	8	8	2.1/3.0	7094
	12	50	3	3400	0.3	12	12	-10	100	FKM	321K4556 ₁	2995	481865	8	9	2.1/3.0	7094
	12	50	3	3400	0.3	12	12	-10	120	FKM	321K4556 ₁	4270	481000	8	8	2.1/3.0	7094
3/4"	18	100	6	9400	0.3	12	12	-10	100	FKM	321K4606	2995	481865	8	9	2.1/3.0	7099
	18	100	6	9400	0.3	12	12	-10	120	FKM	321K4606	4270	481000	8	8	2.1/3.0	7099
	18	100	6	9400	0.3	12	12	-10	100	FKM	321K4656 ₁	2995	481865	8	9	2.1/3.0	7099
	18	100	6	9400	0.3	12	12	-10	120	FKM	321K4656 ₁	4270	481000	8	8	2.1/3.0	7099
	20	135	8.1	9500	0.3	16	16	-10	100	NBR	E321G3610 ₂	2995	481865	8	9	2.0	3442
	20	135	8.1	9500	0.3	16	16	-10	100	NBR	E321G3610 ₂	4270	481000	8	8	2.0	3442

Notes:

1. With manual override

2. With manual override and 4 position selector for controlled closure rate - without manual override and without 4 position selector on request: use same reference removing suffix '10', e.g. E321G36



For this page	Port size	Orifice (mm)	Kv (l/min)	MOPD (bar)	Fluid Temp (°C)
From	1/4"	12	32	12	-10
To	3/4"	20	135	16	120

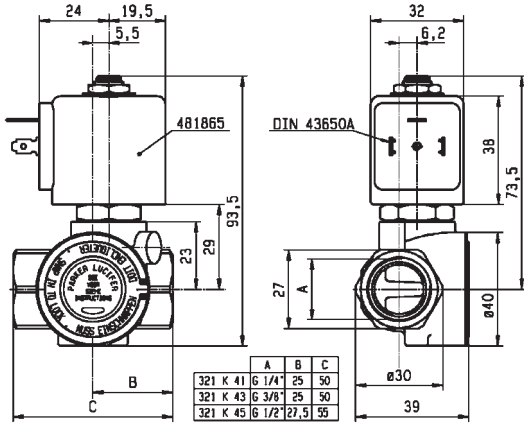

Drawing 7094

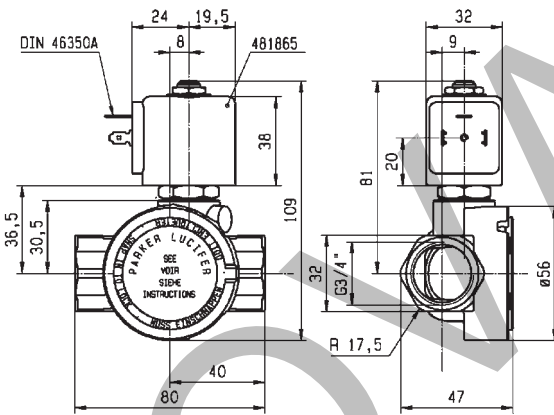

Drawing 7099

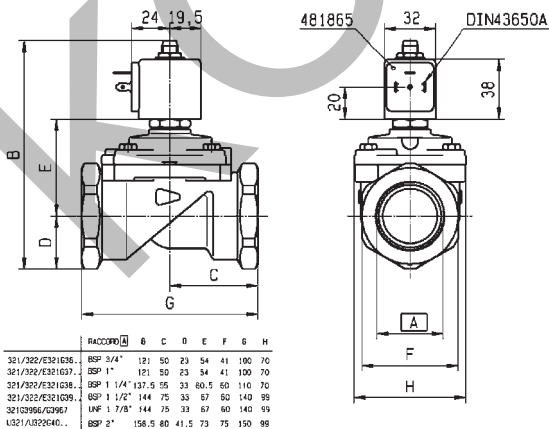

Drawing 3442

2/2

ANTI WATER HAMMER VALVES

PILOT OPERATED

BRASS

PIPE MOUNTING

NORMALLY CLOSED

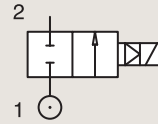

Port size	Orifice Ø	Flow factors			Operating Pressure Differential			Fluid Temp.		Seat Seal	Valve Ref.	Housing Ref.	Coil Ref.	Power		Coil Group	Dwg. No.
		Kv l/min	KV m ³ /h	Qn l/min	Min bar	AC bar	DC bar	Min °C	Max °C					AC W	DC W		
1"	18	110	6.6	10150	0.3	12	12	-10	100	FKM	321K4706	2995	481865	8	9	2.1/3.0	7100
	18	110	6.6	10150	0.3	12	12	-10	120	FKM	321K4706	4270	481000	8	8	2.1/3.0	7100
	18	110	6.6	10150	0.3	12	12	-10	100	FKM	321K4756 ¹	2995	481865	8	9	2.1/3.0	7100
	18	110	6.6	10150	0.3	12	12	-10	120	FKM	321K4756 ¹	4270	481000	8	8	2.1/3.0	7100
	25	180	10.8	14000	0.3	16	16	-10	100	NBR	E321G3710 ²	2995	481865	8	9	2.0	3442
	25	180	10.8	14000	0.3	16	16	-10	100	NBR	E321G3710 ²	4270	481000	8	8	2.0	3442
1 1/4"	28	280	16.8	18000	0.3	16	16	-10	100	NBR	E321G3810 ²	2995	481865	8	9	2.0	3442
	28	280	16.8	18000	0.3	16	16	-10	100	NBR	E321G3810 ²	4270	481000	8	8	2.0	3442
1 1/2"	40	420	25.2	31500	0.3	16	7	-10	100	FKM	E321G3910 ²	2995	481865	8	9	2.0	3442
	40	420	25.2	31500	0.3	16	8.5	-10	100	FKM	E321G3910 ²	4270	481000	8	8	2.0	3442
2"	40	540	32.4	40000	0.3	16	7	-10	100	FKM	E321G4010 ²	2995	481865	8	9	2.0	3442
	40	540	32.4	40000	0.3	16	8.5	-10	100	FKM	E321G4010 ²	4270	481000	8	8	2.0	3442

Notes:

1. With manual override

2. With manual override and 4 position selector for controlled closure rate - without manual override and without 4 position selector on request: use same reference removing suffix '10', e.g. E321G36



For this page	Port size	Orifice (mm)	Kv (l/min)	MOPD (bar)	Fluid Temp (°C)
From	1"	18	110	7	-10
To	2"	40	540	16	120

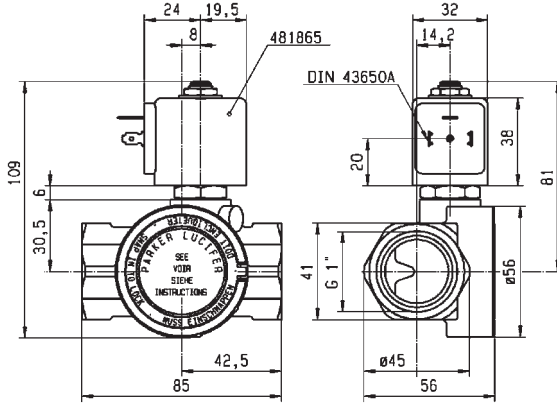

Drawing 7100

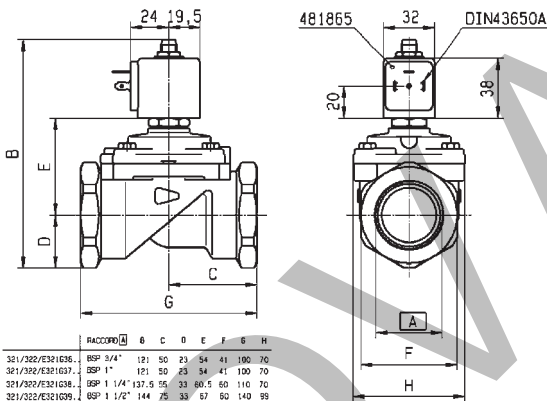

Drawing 3442

RACCORD	B	C	D	E	F	G	H	
321/322/E321G36...	BSP 3/4"	121	50	21	54	41	100	70
321/332/E321G37...	BSP 1"	121	50	23	54	41	100	70
321/330/E321G38...	BSP 1 1/4"	137.5	55	33	60.5	60	110	70
321/322/E321G39...	BSP 1 1/2"	144	75	33	67	60	140	99
321/32965/G2965...	NPT 1 7/8"	144	75	33	67	60	140	99
U321/AU32040...	BSP 2"	156.5	80	41.5	73	75	150	99

2/2

ANTI WATER HAMMER VALVES

PILOT OPERATED

BRASS

PIPE MOUNTING

NORMALLY OPEN

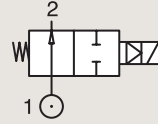

Port size	Orifice Ø	Flow factors			Operating Pressure Differential			Fluid Temp.		Seat Seal	Valve Ref.	Housing Ref.	Coil Ref.	Power		Coil Group	Dwg. No.
		Kv l/min	KV m ³ /h	Qn l/min	Min bar	Max(MOPD) AC bar	DC bar	Min °C	Max °C					AC W	DC W		
3/4"	20	135	8.1	9300	0.3	16	16	-10	100	NBR	322G3610	2995	481865	8	9	2.1	3442
	20	135	8.1	9300	0.3	16	16	-10	100	NBR	322G3610	4270	481000	8	8	2.1	3442
1"	25	180	10.8	14000	0.3	16	16	-10	100	NBR	322G3710	2995	481865	8	9	2.1	3442
	25	180	10.8	14000	0.3	16	16	-10	100	NBR	322G3710	4270	481000	8	8	2.1	3442
1 1/4"	28	270	16.2	18000	0.3	16	16	-10	100	NBR	322G3810	2995	481865	8	9	2.1	3442
	28	270	16.2	18000	0.3	16	16	-10	100	NBR	322G3810	4270	481000	8	8	2.1	3442
1 1/2"	40	425	25.5	31000	0.3	12	12	-10	100	NBR	322G3910	2995	481865	8	9	2.1	3442
	40	425	25.5	31000	0.3	12	12	-10	100	NBR	322G3910	4270	481000	8	8	2.1	3442
2"	40	540	32.4	40000	0.3	12	12	-10	100	NBR	322G4010	2995	481865	8	9	2.1	3442
	40	540	32.4	40000	0.3	12	12	-10	100	NBR	322G4010	4270	481000	8	8	2.1	3442

Notes:

1. With 4 position selector for controlled closure rate



For this page	Port size	Orifice (mm)	Kv (l/min)	MOPD (bar)	Fluid Temp (°C)
From	3/4"	20	135	12	-10
To	2"	40	540	16	100

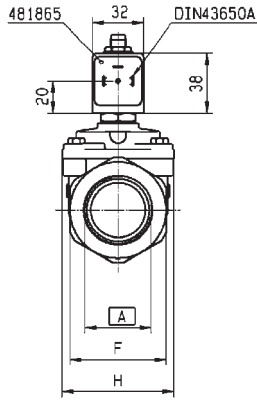
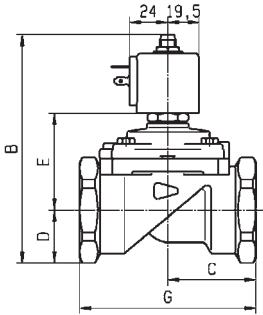

	RACCORD	A	B	C	D	E	F	G	H
321/322/E321G36..	BSP 3/4"	121	50	23	54	41	100	70	
321/332/E321G37..	DSP 1"	121	50	23	54	41	100	70	
321/332/E321G38..	BSP 1 1/4"	137.5	55	33	60.5	60	110	70	
321/332/E321G39..	BSP 1 1/2"	144	75	35	67	50	140	99	
321/336/E321G40..	1/2"	144	75	33	67	60	140	99	
4321/A320E40..	BSP 2"	158.5	80	41.5	73	75	150	99	

Drawing 3442

HOT WATER AND STEAM VALVES



Steam



Water

2/2

Actuation	Body	Function	Port Size	Orifice (mm)	Flow Factor Kv(l/min)	MOPD (bar)	Max Fluid Temp. (°C)	Page Parker Valves
Direct Operated	Brass/Pipe Mounting	Normally Closed	1/4"	3 to 5	11	10	120	102
			3/8"	6	12	5	140	102
			1/2"	8.5 to 11	36	4	120	102
Magnalift	Brass/Pipe Mounting	Normally Closed	1/4"	1.5 to 5	10	100	180	104
			3/8"	15	65	10	140	106
			1/2"	15	65	10	140	106
			3/4"	15	80	10	140	106
			1"	15	80	10	140	106
Pilot Operated	Brass/Pipe Mounting	Normally Closed	1/2"	11 to 16	36	10	140	108

2/2

HOT WATER AND STEAM VALVES

DIRECT OPERATED

BRASS

PIPE MOUNTING

NORMALLY CLOSED

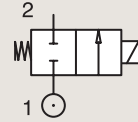

Port size	Orifice Ø	Flow factors			Operating Pressure Differential			Fluid Temp.		Seat Seal	Valve Ref.	Housing Ref.	Coil Ref.	Power		Coil Group	Dwg. No.
		Kv l/min	KV m³/h	Qn l/min	Min bar	Max(MOPD) AC bar	DC bar	Min °C	Max °C					AC W	DC W		
1/4"	3	4.5	0.27	-	0	10	7	0	100	EPDM	121K0323	2995	481865	8	9	2.0	3510
	3	4.5	0.27	-	0	10	8.5	0	120	EPDM	121K0323	4270	481000	8	8	2.0	3510
	3	4.5	0.27	-	0	10	10	0	120	EPDM	121K0323	4270	486265	14	14	2.0	3510
	3	4.5	0.27	-	0	10	10	0	120	EPDM	121K0323	2995	492425	14	14	2.0	3510
	5	11	0.66	750	0	7	2	0	100	EPDM	121K0103	2995	481865	8	9	2.0	3510
	5	11	0.66	750	0	7	2.8	0	120	EPDM	121K0103	4270	481000	8	8	2.0	3510
	5	11	0.66	750	0	7	5	0	120	EPDM	121K0103	4270	486265	14	14	2.0	3510
	5	11	0.66	750	0	4	3.5	0	120	EPDM	121K0103	2995	492425	14	14	2.0	3510
3/8"	6	12	0.72	1100	0	5	1.1	0	100	EPDM	121K3303	2995	481865	8	9	2.0	3551
	6	12	0.72	1100	0	5	1.5	0	120	EPDM	121K3303	4270	481000	8	8	2.0	3551
	6	12	0.72	1100	0	4	4	0	120	EPDM	121K3303	4270	486265	14	14	2.0	3551
	6	12	0.72	1100	0	4	4	0	140	EPDM	121K3303	2995	492425	14	14	2.0	3551
1/2"	8.5	25	1.5	-	0	2.2	0.5	0	120	EPDM	E121K4603	4270	481000	8	8	2.0	3427
	8.5	25	1.5	-	0	4	1.2	0	120	EPDM	E121K4603	4270	486265	14	14	2.0	3427
	8.5	25	1.5	-	0	4	1	0	120	EPDM	E121K4603	2995	492425	14	14	2.0	3427
	11	36	2.16	-	0	1.2	0.35	0	120	EPDM	E121K4503	4270	481000	8	8	2.0	3427
	11	36	2.16	-	0	2.5	0.7	0	120	EPDM	E121K4503	4270	486265	14	14	2.0	3427
	11	36	2.16	-	0	2.5	0.5	0	120	EPDM	E121K4503	2995	492425	14	14	2.0	3427



For this page	Port size	Orifice (mm)	Kv (l/min)	MOPD (bar)	Fluid Temp (°C)
From	1/4"	3	4.5	0.35	0
To	1/2"	11	36	10	140

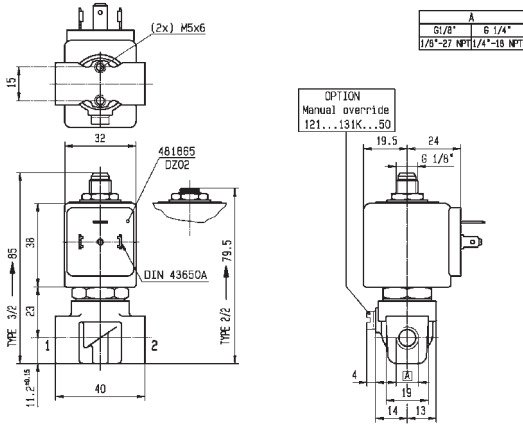

Drawing 3510

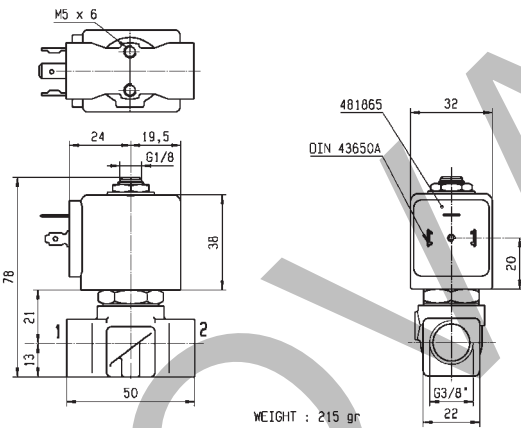

Drawing 3551

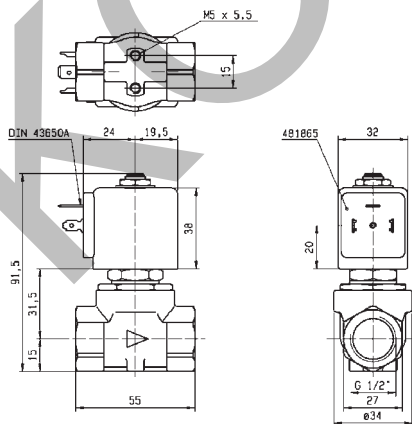

Drawing 3427

2/2

HOT WATER AND STEAM VALVES

DIRECT OPERATED

303 STAINLESS ST.

PIPE MOUNTING

NORMALLY CLOSED

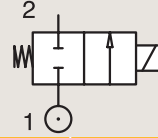

Port size (BSP)	Orifice Ø			Flow factors			Operating Pressure Differential Max(MOPD)			Fluid Temp.		Seat Seal	Valve Ref.	Housing Ref.	Coil Ref.	Power		Coil Group	Dwg. No.
	mm	Kv l/min	KV m ³ /h	Qn m ³ /h	Min bar	AC bar	DC bar	Min °C	Max °C	AC W	DC W								
1/4"	1.5	1.5	0.09	80	0	60	25	0	100	Ruby	121V5463	2995	481865	8	9	2.0	8116		
	1.5	1.5	0.09	80	0	75	30	0	130	Ruby	121V5463	4270	481000	8	8	2.0	8116		
	1.5	1.5	0.09	80	0	100	55	0	140	Ruby	121V5463	4270	486265	14	14	2.0	8116		
	2.5	3.5	0.21	220	0	28	10	0	100	Ruby	121V5763	2995	481865	8	9	2.0	8116		
	2.5	3.5	0.21	220	0	34	12	0	130	Ruby	121V5763	4270	481000	8	8	2.0	8116		
	2.5	3.5	0.21	220	0	50	22	0	140	Ruby	121V5763	4270	486265	14	14	2.0	8116		
	3	4.5	0.27	315	0	20	7	0	100	Ruby	121V5363	2995	481865	8	9	2.0	8116		
	3	4.5	0.27	315	0	25	8.5	0	130	Ruby	121V5363	4270	481000	8	8	2.0	8116		
	3	4.5	0.27	315	0	36	15	0	140	Ruby	121V5363	4270	486265	14	14	2.0	8116		
	4	7	0.42	450	0	12	4	0	100	Ruby	121V5263	2995	481865	8	9	2.0	8116		
	4	7	0.42	450	0	15	5	0	130	Ruby	121V5263	4270	481000	8	8	2.0	8116		
	4	7	0.42	450	0	22	10	0	180	Ruby	121V5263	4270	486265	14	14	2.0	8116		
	5	10	0.6	750	0	8.5	2	0	100	Ruby	121V5163	2995	481865	8	9	2.0	8116		
	5	10	0.6	750	0	10	3.5	0	130	Ruby	121V5163	4270	481000	8	8	2.0	8116		
5	10	0.6	750	0	14	6.5	0	140	Ruby	121V5163	4270	486265	14	14	2.0	8116			
1/4" NPT	3	4.5	0.27	315	0	20	7	0	100	Ruby	U121V5363	2995	481865	8	8	2.0	8116		



For this page	Port size	Orifice (mm)	Kv (l/min)	MOPD (bar)	Fluid Temp (°C)
From	1/4"	1.5	1.5	2	0
To	1/4"	5	10	100	180

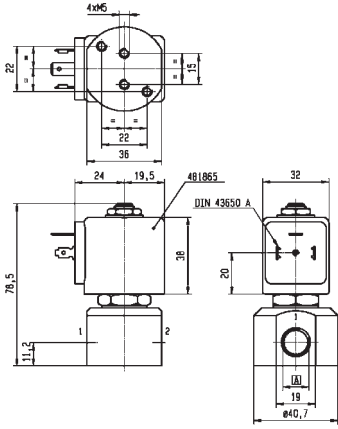

A	G 1/8"
	G 1/4"



Drawing 8116

KOOLVARI

2/2

HOT WATER AND STEAM VALVES

MAGNALIFT

BRASS

PIPE MOUNTING

NORMALLY CLOSED

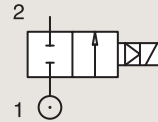

Port size	Orifice Ø	Flow factors			Operating Pressure Differential			Fluid Temp.		Seat Seal	Valve Ref.	Housing Ref.	Coil Ref.	Power		Coil Group	Dwg. No.
		Kv l/min	KV m³/h	Qn l/min	Min bar	Max(MOPD) AC bar	DC bar	Min °C	Max °C					AC W	DC W		
3/8"	15	65	3.9	-	0	10	-	0	100	EPDM	221G1303	2995	481865	8	-	2.0	3732
	15	65	3.9	-	0	10	-	0	120	EPDM	221G1303	4270	481000	8	-	2.0	3732
	15	65	3.9	-	0	4	4	0	140	EPDM	221G1303	4270	486265	14	14	2.0	3732
	15	65	3.9	4500	0	10	10	-10	100	NBR	221G1330	2995	481865	8	9	2.1	3732
	15	65	3.9	4500	0	10	10	-10	65	NBR	221G1330	-	492070	9	8	2.1	3732
1/2"	15	65	3.9	-	0	10	-	0	100	EPDM	221G1503	2995	481865	8	-	2.0	3732
	15	65	3.9	-	0	10	-	0	120	EPDM	221G1503	4270	481000	8	-	2.0	3732
	15	65	3.9	-	0	10	7	0	140	EPDM	221G1503	4270	486265	14	14	2.0	3732
3/4"	15	80	4.8	-	0	10	-	0	100	EPDM	221G1603	2995	481865	8	-	2.0	3444
	15	80	4.8	-	0	10	-	0	120	EPDM	221G1603	4270	481000	8	-	2.0	3444
	15	80	4.8	-	0	4	4	0	140	EPDM	221G1603	4270	486265	14	14	2.0	3444
1"	15	80	4.8	6000	0	10	-	0	100	EPDM	221G1703	2995	481865	8	-	2.0	3445
	15	80	4.8	6000	0	10	-	0	120	EPDM	221G1703	2995	481000	8	-	2.0	3445
	15	80	4.8	6000	0	10	10	0	140	EPDM	221G1703	2995	486265	14	14	2.0	3445

Notes:

1. Valves with model number ending in 30 or 31 are mainly equipped with electrical parts for explosion proof applications or with standard DC coils.



For this page	Port size	Orifice (mm)	Kv (l/min)	MOPD (bar)	Fluid Temp (°C)
From	3/8"	15	65	4	-10
To	1"	15	80	10	140

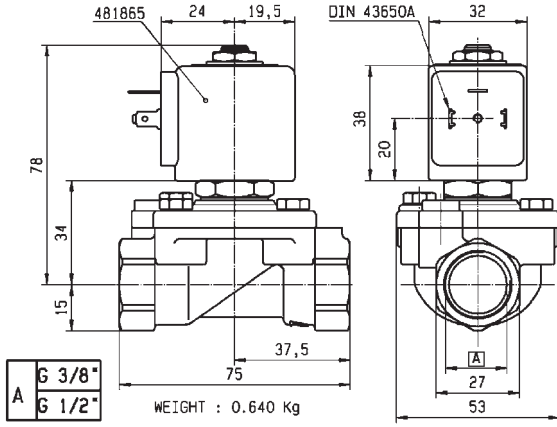

Drawing 3732

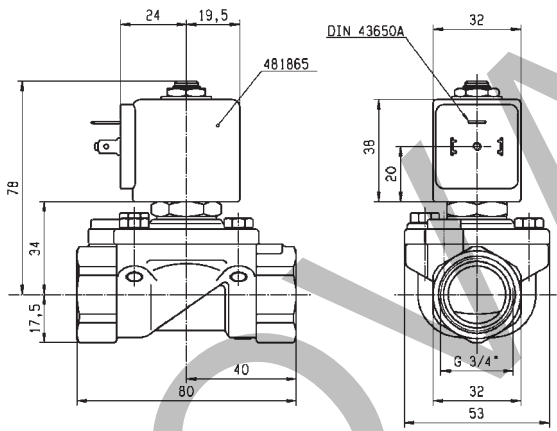

Drawing 3444

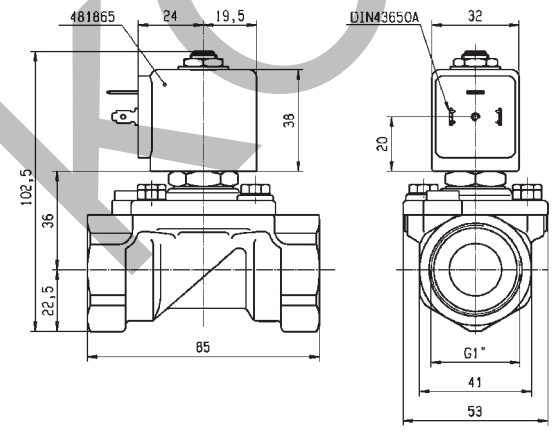

Drawing 3445

2/2

HOT WATER AND STEAM VALVES

PILOT OPERATED

BRASS

PIPE MOUNTING

NORMALLY CLOSED

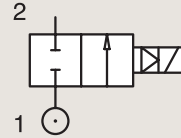

Port size (BSP)	Orifice Ø mm	Flow factors			Operating Pressure Differential Max(MOPD)			Fluid Temp.		Seat Seal	Valve Ref.	Housing Ref.	Coil Ref.	Power		Coil Group	Dwg. No.
		Kv l/min	KV m³/h	Qn m³/h	Min bar	AC bar	DC bar	Min °C	Max °C					AC W	DC W		
1/2"	11	36	2.16	2500	0.2	10	3	0	100	EPDM	E321K1503	2995	481865	8	9	2.0	3427
	11	36	2.16	2500	0.2	10	4	0	120	EPDM	E321K1503	4270	481000	8	8	2.0	3427
	11	36	2.16	2500	0.2	10	10	0	140	EPDM	E321K1503	4270	486265	14	14	2.0	3427

Notes:

1. Maximum pressure for steam: 4Bar (140°C)



For this page	Port size	Orifice (mm)	Kv (l/min)	MOPD (bar)	Fluid Temp (°C)
From	1/2"	11	36	3	0
To	1/2"	11	36	10	140

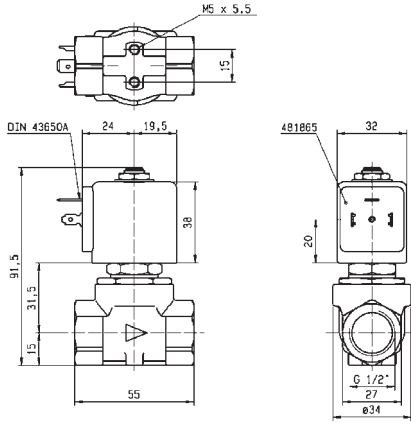

Drawing 3427

KOOLVARI.COM



VALVES FOR HYDRAULIC OIL AND NEUTRAL LIQUIDS (UP TO 100 BAR)



2/2

Actuation	Body	Function	Port Size	Orifice (mm)	Flow Factor Kv(l/min)	MOPD (bar)	Max Fluid Temp. (°C)	Page Parker Valves	
Direct Operated	Brass/Pipe Mounting	Normally Closed	1/8"	1.5 to 2.5	3.5	70	130	112	
			1/4"	1.2 to 3	4.5	100	130	112	
			3/8"	4 to 6	12	10	120	114	
		Normally Open	1/8"	2.5	3.5	30	140	114	
			1/4"	1.5 to 2.5	3.5	40	140	114	
			Brass/Sub-base Mounting	Normally Closed	5 mm	1.5 to 3	4.5	100	130
Pilot Operated	Brass/Pipe Mounting	Normally Closed	1/4"	8	36	40	140	118	
			3/8"	11	50	40	140	118	
			1/2"	15	60	40	140	120	
		Normally Open	1/4"	8	36	40	140	122	
			3/8"	11	50	40	140	122	
			1/2"	15	60	40	140	122	
		Brass/Sub-base Mounting	Normally Closed	14 mm	14	45	40	140	124
			Normally Open	14 mm	14	45	40	120	124

KOVAL

2/2

VALVES FOR HYDRAULIC OIL AND NEUTRAL LIQUIDS (UP TO 100 BAR) DIRECT OPERATED

BRASS

PIPE MOUNTING

NORMALLY CLOSED

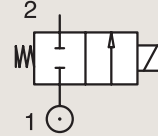

Port size (BSP)	Orifice Ø			Flow factors			Operating Pressure Differential Max(MOPD)			Fluid Temp.		Seat Seal	Valve Ref.	Housing Ref.	Coil Ref.	Power		Coil Group	Dwg. No.
	mm	Kv l/min	KV m³/h	Qn m³/h	Min bar	AC bar	DC bar	Min °C	Max °C	AC W	DC W								
1/8"	1.5	1.5	0.09	80	0	60	25	-30	75	PCTFE	E121K14	2995	481865	8	9	2.0	3510		
	1.5	1.5	0.09	80	0	70	30	-30	75	PCTFE	E121K14	4270	481000	8	8	2.0	3510		
	1.5	1.5	0.09	80	0	70	55	-30	75	PCTFE	E121K14	4270	486265	14	14	2.0	3510		
	2.5	3.5	0.21	220	0	28	10	-30	100	Ruby	E121K23	2995	481865	8	9	2.0	3510		
	2.5	3.5	0.21	220	0	34	12	-30	130	Ruby	E121K23	4270	481000	8	8	2.0	3510		
	2.5	3.5	0.21	220	0	50	22	-30	120	Ruby	E121K23	4270	486265	14	14	2.0	3510		
1/4"	1.2	0.85	0.05	50	0	80	36	-30	100	Ruby	E121K65	2995	481865	8	9	2.0	3510		
	1.2	0.85	0.05	50	0	100	43	-30	130	Ruby	E121K65	4270	481000	8	8	2.0	3510		
	1.2	0.85	0.05	50	0	100	75	-30	120	Ruby	E121K65	4270	486265	14	14	2.0	3510		
	1.5	1.5	0.09	80	0	60	25	-30	75	PCTFE	E121K04	2995	481865	8	9	2.0	3510		
	1.5	1.5	0.09	80	0	70	30	-30	75	PCTFE	E121K04	4270	481000	8	8	2.0	3510		
	1.5	1.5	0.09	80	0	70	55	-30	75	PCTFE	E121K04	4270	486265	14	14	2.0	3510		
	1.5	1.5	0.09	80	0	60	25	-30	100	Ruby	E121K67	2995	481865	8	9	2.0	3510		
	1.5	1.5	0.09	80	0	75	30	-30	130	Ruby	E121K67	4270	481000	8	8	2.0	3510		
	1.5	1.5	0.09	80	0	100	55	-30	120	Ruby	E121K67	4270	486265	14	14	2.0	3510		
	2.5	3.5	0.21	220	0	28	10	-30	100	Ruby	E121K63	2995	481865	8	9	2.0	3510		
	2.5	3.5	0.21	220	0	34	12	-30	130	Ruby	E121K63	4270	481000	8	8	2.0	3510		
	2.5	3.5	0.21	220	0	50	22	-30	120	Ruby	E121K63	4270	486265	14	14	2.0	3510		
	3	4.5	0.27	320	0	20	7	-30	75	PCTFE	E121K03	2995	481865	8	9	2.0/3.0	3510		
	3	4.5	0.27	320	0	25	8.5	-30	75	PCTFE	E121K03	4270	481000	8	8	2.0/3.0	3510		
	3	4.5	0.27	320	0	36	15	-30	75	PCTFE	E121K03	4270	486265	14	14	2.0/3.0	3510		
	3	4.5	0.27	320	0	20	7	-30	100	Ruby	E121K64	2995	481865	8	9	2.0	3510		
	3	4.5	0.27	320	0	25	8.5	-30	130	Ruby	E121K64	4270	481000	8	8	2.0	3510		
	3	4.5	0.27	320	0	36	15	-30	120	Ruby	E121K64	4270	486265	14	14	2.0	3510		



For this page	Port size	Orifice (mm)	Kv (l/min)	MOPD (bar)	Fluid Temp (°C)
From	1/8"	1.2	0.85	7	-30
To	1/4"	3	4.5	100	130

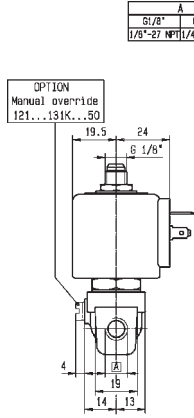
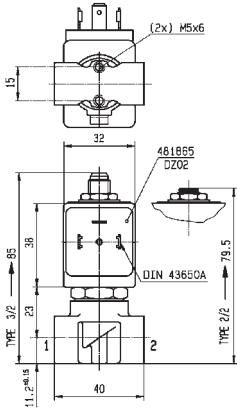

A	
6/8"	6 1/4"
1/8"-27 NPT	1/4"-18 NPT



Drawing 3510

KOVALAN

2/2

VALVES FOR HYDRAULIC OIL AND NEUTRAL LIQUIDS (UP TO 100 BAR) DIRECT OPERATED

BRASS

PIPE MOUNTING

NORMALLY CLOSED

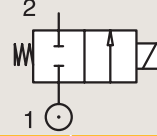

Port size (BSP)	Orifice Ø mm	Flow factors			Operating Pressure Differential Max(MOPD)			Fluid Temp.		Seat Seal	Valve Ref.	Housing Ref.	Coil Ref.	Power		Coil Group	Dwg. No.
		Kv l/min	KV m³/h	Qn m³/h	Min bar	AC bar	DC bar	Min °C	Max °C					AC W	DC W		
3/8"	4	7.5	0.45	480	0	10	4	-10	100	FKM	121K3206	2995	481865	8	9	2.0	3551
	4	7.5	0.45	480	0	10	5	-10	120	FKM	121K3206	4270	481000	8	8	2.0	3551
	4	7.5	0.45	480	0	10	10	-10	120	FKM	121K3206	4270	486265	14	14	2.0	3551
	5	11	0.66	750	0	7	2	-10	100	FKM	121K3106	2995	481865	8	9	2.0	3551
	5	11	0.66	750	0	7	2.8	-10	120	FKM	121K3106	4270	481000	8	8	2.0	3551
	5	11	0.66	750	0	7	5	-10	120	FKM	121K3106	4270	486265	14	14	2.0	3551
	6	12	0.72	1100	0	5	1.1	-10	100	FKM	121K3306	2995	481865	8	9	2.0/14.2	3551
	6	12	0.72	1100	0	5	1.5	-10	120	FKM	121K3306	4270	481000	8	8	2.0/14.2	3551
	6	12	0.72	1100	0	5	3	-10	120	FKM	121K3306	4270	486265	14	14	2.0/14.2	3551

BRASS

PIPE MOUNTING

NORMALLY OPEN

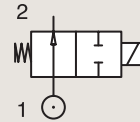

Port size (BSP)	Orifice Ø mm	Flow factors			Operating Pressure Differential Max(MOPD)			Fluid Temp.		Seat Seal	Valve Ref.	Housing Ref.	Coil Ref.	Power		Coil Group	Dwg. No.
		Kv l/min	KV m³/h	Qn m³/h	Min bar	AC bar	DC bar	Min °C	Max °C					AC W	DC W		
1/8"	2.5	3.5	0.21	-	0	30	-	-30	140	Ruby	122K9363	4270	481044	14	-	2.2	3510
	2.5	3.5	0.21	-	0	30	30	-30	140	Ruby	122K9363	4270	486265	14	14	2.2	3510
1/4"	1.5	1.5	0.09	80	0	30	30	-10	100	PCTFE	122K84	2995	481865	8	9	2.0	3510
	1.5	1.5	0.09	80	0	30	30	-10	100	PCTFE	122K84	4270	481000	8	8	2.0	3510
	1.5	1.5	0.09	80	0	30	30	-10	120	PCTFE	122K84	4270	486265	14	14	2.0	3510
	1.5	1.5	0.09	80	0	40	40	-30	100	Ruby	122K8408	2995	481865	8	9	2.0	3510
	1.5	1.5	0.09	80	0	40	40	-30	130	Ruby	122K8408	4270	481000	8	8	2.0	3510
	1.5	1.5	0.09	80	0	40	40	-30	130	Ruby	122K8408	4270	486265	14	14	2.0	3510
	2.5	3.5	0.21	-	0	30	-	-30	140	Ruby	122K8363	4270	481044	14	-	2.2	3510
	2.5	3.5	0.21	-	0	30	30	-30	140	Ruby	122K8363	4270	486265	14	14	2.2	3510



For this page	Port size	Orifice (mm)	Kv (l/min)	MOPD (bar)	Fluid Temp (°C)
From	1/8"	1.5	1.5	1.1	-30
To	3/8"	6	12	40	140

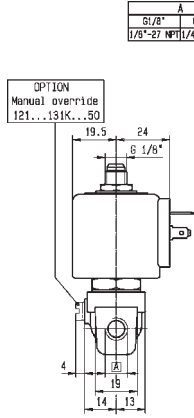
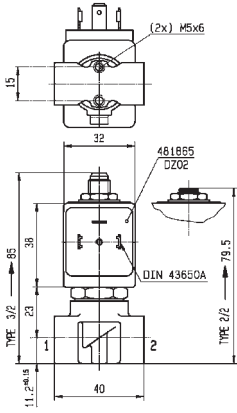

A	
6/8"	6 1/4"
1/8"-27 NPT	1/4"-18 NPT



Drawing 3510

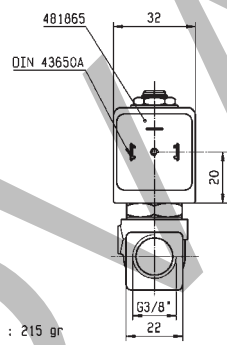
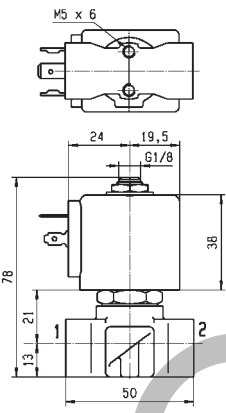

WEIGHT : 215 gr



Drawing 3551

2/2

VALVES FOR HYDRAULIC OIL AND NEUTRAL LIQUIDS (UP TO 100 BAR) DIRECT OPERATED

BRASS

SUB-BASE MOUNTING

NORMALLY CLOSED

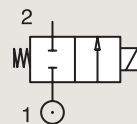

Port size	Orifice Ø			Flow factors			Operating Pressure Differential			Fluid Temp.		Seat Seal	Valve Ref.	Housing Ref.	Coil Ref.	Power		Coil Group	Dwg. No.
	mm	Kv l/min	KV m³/h	Qn l/min	Min bar	Max(MOPD) AC bar	DC bar	Min °C	Max °C	AC W	DC W								
SB	1.5	1.5	0.09	80	0	60	25	-30	100	Ruby	121F67	2995	481865	8	9	2.0	3509		
	1.5	1.5	0.09	80	0	75	30	-30	130	Ruby	121F67	4270	481000	8	8	2.0	3509		
	1.5	1.5	0.09	80	0	100	55	-30	120	Ruby	121F67	4270	486265	14	14	2.0	3509		
	1.5	1.5	0.09	80	0	60	25	-30	75	PCTFE	E121F44	2995	481865	8	9	2.0	3509		
	1.5	1.5	0.09	80	0	70	30	-30	75	PCTFE	E121F44	4270	481000	8	8	2.0	3509		
	1.5	1.5	0.09	80	0	70	55	-30	75	PCTFE	E121F44	4270	486265	14	14	2.0	3509		
	2.5	3.5	0.21	220	0	14	7	-10	100	FKM	121F4706	2995	481865	8	9	2.0	3509		
	2.5	3.5	0.21	220	0	14	9	-10	120	FKM	121F4706	4270	481000	8	8	2.0	3509		
	2.5	3.5	0.21	220	0	14	14	-10	120	FKM	121F4706	4270	486265	14	14	2.0	3509		
	2.5	3.5	0.21	220	0	28	10	-30	100	Ruby	121F63	2995	481865	8	9	2.0	3509		
	2.5	3.5	0.21	220	0	34	12	-30	130	Ruby	121F63	4270	481000	8	8	2.0	3509		
	2.5	3.5	0.21	220	0	50	22	-30	120	Ruby	121F63	4270	486265	14	14	2.0	3509		
	3	4.5	0.27	320	0	20	7	-30	100	Ruby	121F64	2995	481865	8	9	2.0	3509		
	3	4.5	0.27	320	0	25	8.5	-30	130	Ruby	121F64	4270	481000	8	8	2.0	3509		
	3	4.5	0.27	320	0	36	15	-30	120	Ruby	121F64	4270	486265	14	14	2.0	3509		
	3	4.5	0.27	320	0	20	7	-30	75	PCTFE	E121F43	2995	481865	8	9	2.0	3509		
	3	4.5	0.27	320	0	25	8.5	-30	75	PCTFE	E121F43	4270	481000	8	8	2.0	3509		
	3	4.5	0.27	320	0	36	15	-30	75	PCTFE	E121F43	4270	486265	14	14	2.0	3509		

2/2

VALVES FOR HYDRAULIC OIL AND NEUTRAL LIQUIDS (UP TO 100 BAR) PILOT OPERATED

BRASS

PIPE MOUNTING

NORMALLY CLOSED

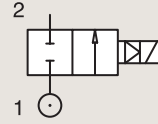

Port size	Orifice Ø	Flow factors			Operating Pressure Differential			Fluid Temp.		Seat Seal	Valve Ref.	Housing Ref.	Coil Ref.	Power		Coil Group	Dwg. No.
		Kv l/min	KV m³/h	Qn l/min	Min bar	AC bar	DC bar	Min °C	Max °C					AC W	DC W		
1/4"	8	36	2.16	1600	0.3	40	25	-10	100	NBR	E321H11 ¹²	2995	481865	8	9	2.0	3523
	8	36	2.16	1600	0.3	40	30	-10	100	NBR	E321H11 ¹²	4270	481000	8	8	2.0	3523
	8	36	2.16	1600	0.3	40	40	-10	100	NBR	E321H11 ¹²	4270	486265	14	14	2.0	3523
	8	36	2.16	-	0.3	40	25	-10	100	FKM	E321H21 ¹²	2995	481865	8	9	2.0	3523
	8	36	2.16	-	0.3	40	30	-10	120	FKM	E321H21 ¹²	4270	481000	8	8	2.0	3523
	8	36	2.16	-	0.3	40	40	-10	140	FKM	E321H21 ¹²	4270	486265	14	14	2.0	3523
3/8"	11	50	3	2800	0.3	40	25	-10	100	NBR	E321H13 ¹²	2995	481865	8	9	2.0	3521
	11	50	3	2800	0.3	40	30	-10	100	NBR	E321H13 ¹²	4270	481000	8	8	2.0	3521
	11	50	3	2800	0.3	40	40	-10	100	NBR	E321H13 ¹²	4270	486265	14	14	2.0	3521
	11	50	3	-	0.3	40	25	-10	100	FKM	E321H23 ¹²	2995	481865	8	9	2.0	3521
	11	50	3	-	0.3	40	30	-10	120	FKM	E321H23 ¹²	4270	481000	8	8	2.0	3521
	11	50	3	-	0.3	40	40	-10	140	FKM	E321H23 ¹²	4270	486265	14	14	2.0	3521
	11	36	2.16	-	0.2	20	3	-10	100	Ruby	E321K63	2995	483510	9	-	2.0	3429
	11	36	2.16	-	0.2	30	4	-10	140	Ruby	E321K63	4270	488553	9	-	2.0	3429
11	36	2.16	-	0.2	4	4	-10	75	Ruby	E321K63	-	492190	11	9	2.0	3429	

Notes:

1. Minimum pressure differential = 0.3 bar for opening and 0 bar for closing
2. Pilot seat disc in synthetic Ruby



For this page	Port size	Orifice (mm)	Kv (l/min)	MOPD (bar)	Fluid Temp (°C)
From	1/4"	8	36	3	-10
To	3/8"	11	50	40	140

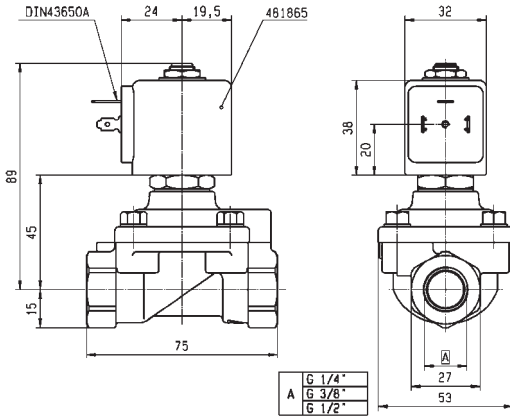

Drawing 3523

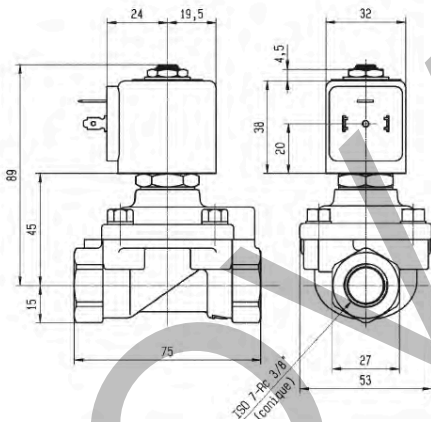

Drawing 3521

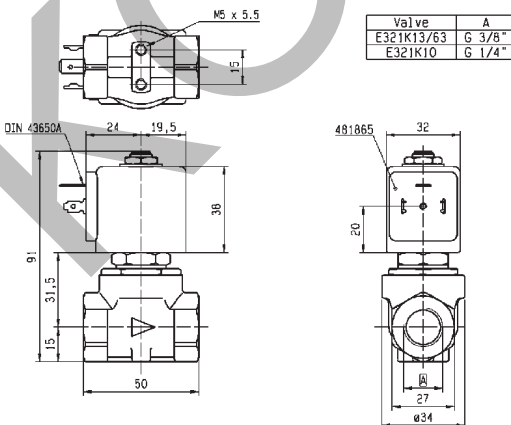

Drawing 3429

2/2

VALVES FOR HYDRAULIC OIL AND NEUTRAL LIQUIDS (UP TO 100 BAR) PILOT OPERATED

BRASS

PIPE MOUNTING

NORMALLY CLOSED

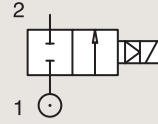

Port size	Orifice Ø	Flow factors			Operating Pressure Differential			Fluid Temp.		Seat Seal	Valve Ref.	Housing Ref.	Coil Ref.	Power		Coil Group	Dwg. No.
		Kv l/min	KV m³/h	Qn l/min	Min bar	Max(MOPD) AC bar	DC bar	Min °C	Max °C					AC W	DC W		
1/2"	15	60	3.6	3150	0.3	40	25	-10	100	NBR	E321H15 ¹²	2995	481865	8	9	2.0	3522
	15	60	3.6	3150	0.3	40	30	-10	100	NBR	E321H15 ¹²	4270	481000	8	8	2.0	3522
	15	60	3.6	3150	0.3	40	40	-10	100	NBR	E321H15 ¹²	4270	486265	14	14	2.0	3522
	15	60	3.6	-	0.3	40	25	-10	100	FKM	E321H25 ¹²	2995	481865	8	9	2.0/14.2	3522
	15	60	3.6	-	0.3	40	30	-10	65	FKM	E321H25 ¹²	-	483371	8	8	2.0/14.2	3522
	15	60	3.6	-	0.3	40	40	-10	140	FKM	E321H25 ¹²	4270	486265	14	14	2.0/14.2	3522

Notes:

- 1. Minimum pressure differential = 0.3 bar for opening and 0 bar for closing
- 2. Pilot seat disc in synthetic Ruby



For this page	Port size	Orifice (mm)	Kv (l/min)	MOPD (bar)	Fluid Temp (°C)
From	1/2"	15	60	25	-10
To	1/2"	15	60	40	140

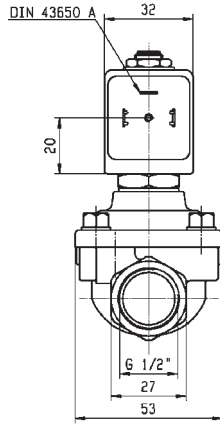
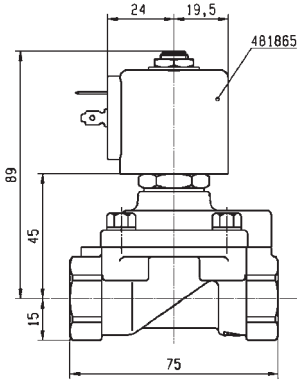

Drawing 3522

KOLVAN

2/2

VALVES FOR HYDRAULIC OIL AND NEUTRAL LIQUIDS (UP TO 100 BAR) PILOT OPERATED

BRASS

PIPE MOUNTING

NORMALLY OPEN

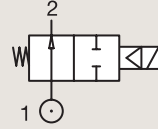

Port size	Orifice Ø	Flow factors			Operating Pressure Differential			Fluid Temp.		Seat Seal	Valve Ref.	Housing Ref.	Coil Ref.	Power		Coil Group	Dwg. No.
		Kv l/min	KV m³/h	Qn l/min	Min bar	Max(MOPD) AC bar	DC bar	Min °C	Max °C					AC W	DC W		
1/4"	8	36	2.16	1600	0.3	40	40	-10	100	FKM	322H7106 ¹²	2995	481865	8	9	2.0/14.1	3523
	8	36	2.16	1600	0.3	40	40	-10	120	FKM	322H7106 ¹²	4270	481000	8	8	2.0/14.1	3523
	8	36	2.16	1600	0.3	40	40	-10	140	FKM	322H7106 ¹²	4270	486265	14	14	2.0/14.1	3523
3/8"	11	50	3	3240	0.3	40	40	-10	75	NBR	322H73 ¹²	2995	481865	8	9	2.0	3523
	11	50	3	3240	0.3	40	40	-10	75	NBR	322H73 ¹²	4270	481000	8	8	2.0	3523
	11	50	3	3240	0.3	40	40	-10	75	NBR	322H73 ¹²	4270	486265	14	14	2.0	3523
	11	50	3	3240	0.3	40	40	-10	100	FKM	322H7306 ¹²	2995	481865	8	9	2.0/14.1	3523
	11	50	3	3240	0.3	40	40	-10	100	FKM	322H7306 ¹²	4270	481000	8	8	2.0/14.1	3523
	11	50	3	3240	0.3	40	40	-10	140	FKM	322H7306 ¹²	4270	486265	14	14	2.0/14.1	3523
1/2"	15	60	3.6	3890	0.3	20	20	-10	100	FKM	322G7506 ¹	2995	481865	8	9	2.0	3522
	15	60	3.6	3890	0.3	20	20	-10	100	FKM	322G7506 ¹	4270	481000	8	8	2.0	3522
	15	60	3.6	3890	0.3	20	20	-10	100	FKM	322G7506 ¹	4270	486265	14	14	2.0	3522
	15	60	3.6	3890	0.3	40	40	-10	100	NBR	322H75 ¹²	2995	481865	8	9	2.0	3522
	15	60	3.6	3890	0.3	40	40	-10	100	NBR	322H75 ¹²	4270	481000	8	8	2.0	3522
	15	60	3.6	3890	0.3	40	40	-10	100	NBR	322H75 ¹²	4270	486265	14	14	2.0	3522
	15	60	3.6	3890	0.3	40	40	-10	100	FKM	322H7506 ¹²	2995	481865	8	9	2.0/14.1	3522
	15	60	3.6	3890	0.3	40	40	-10	120	FKM	322H7506 ¹²	4270	481000	8	8	2.0/14.1	3522
15	60	3.6	3890	0.3	40	40	-10	140	FKM	322H7506 ¹²	4270	486265	14	14	2.0/14.1	3522	

Notes:

- 1. Minimum pressure differential = 0.3 bar for opening and 0 bar for closing
- 2. Pilot seat disc in synthetic Ruby



For this page	Port size	Orifice (mm)	Kv (l/min)	MOPD (bar)	Fluid Temp (°C)
From	1/4"	8	36	20	-10
To	1/2"	15	60	40	140

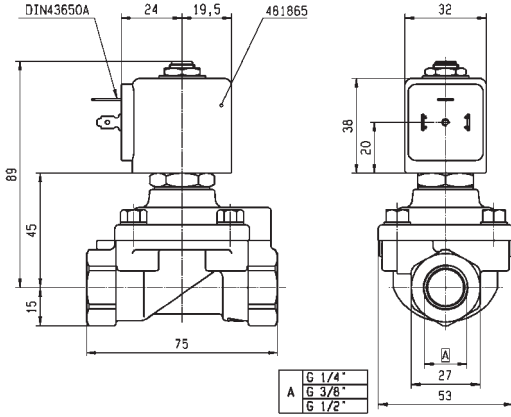

Drawing 3523

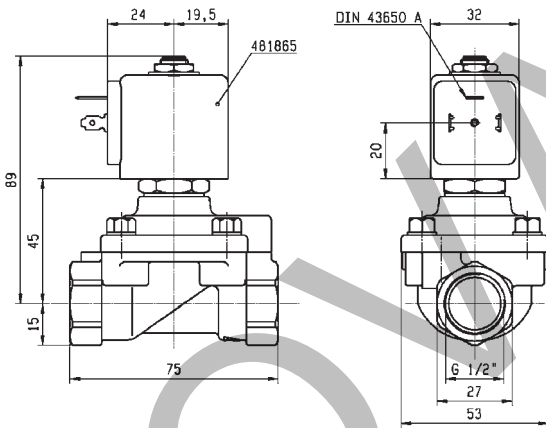

Drawing 3522

2/2

VALVES FOR HYDRAULIC OIL AND NEUTRAL LIQUIDS (UP TO 100 BAR) PILOT OPERATED

BRASS

SUB-BASE MOUNTING

NORMALLY CLOSED

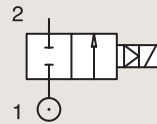

Port size	Orifice Ø	Flow factors			Operating Pressure Differential			Fluid Temp.		Seat Seal	Valve Ref.	Housing Ref.	Coil Ref.	Power		Coil Group	Dwg. No.
		Kv l/min	KV m³/h	Qn l/min	Min bar	Max(MOPD) AC bar	DC bar	Min °C	Max °C					AC W	DC W		
BSP	14	45	2.7	-	0.3	40	25	-10	100	FKM	E321F3202 ₁₂	2995	481865	8	9	2.0	3520
SB	14	45	2.7	-	0.3	40	30	-10	120	FKM	E321F3202 ₁₂	4270	481000	8	8	2.0	3520
	14	45	2.7	-	0.3	40	40	-10	140	FKM	E321F3202 ₁₂	4270	486265	14	14	2.0	3520

Notes:

1. Minimum pressure differential = 0.3 bar for opening and 0 bar for closing
2. Pilot seat disc in synthetic Ruby

BRASS

SUB-BASE MOUNTING

NORMALLY OPEN

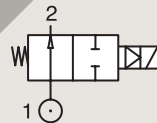

Port size	Orifice Ø	Flow factors			Operating Pressure Differential			Fluid Temp.		Seat Seal	Valve Ref.	Housing Ref.	Coil Ref.	Power		Coil Group	Dwg. No.
		Kv l/min	KV m³/h	Qn l/min	Min bar	Max(MOPD) AC bar	DC bar	Min °C	Max °C					AC W	DC W		
BSP	14	45	2.7	-	0.3	40	40	0	100	FKM	322F7206 ₁₂	2995	481865	8	9	2.1/14.1	3520
SB	14	45	2.7	-	0.3	40	40	0	120	FKM	322F7206 ₁₂	4270	481000	8	8	2.1/14.1	3520

Notes:

1. Minimum pressure differential = 0.3 bar for opening and 0 bar for closing
2. Pilot seat disc in synthetic Ruby



For this page	Port size	Orifice (mm)	Kv (l/min)	MOPD (bar)	Fluid Temp (°C)
From	14 mm	14	45	25	-10
To	14 mm	14	45	40	140

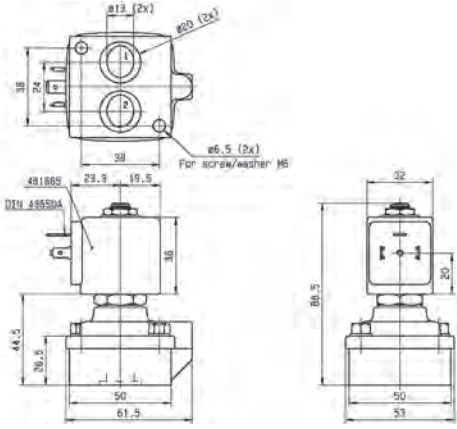

Drawing 3520

KOLVAR



HIGH CORROSION RESISTANT VALVES (303 STAINLESS ST.) STEEL



2/2

Actuation	Body	Function	Port Size	Orifice (mm)	Flow Factor Kv(l/min)	MOPD (bar)	Max Fluid Temp. (°C)	Page Parker Valves
Direct Operated	303 Stainless St./Pipe Mounting	Normally Closed	1/4"	1.5 to 5	10	100	180	128 and 130
		Normally Open	1/4"	2.5	3	12	120	132

KONVAVI

2/2

HIGH CORROSION RESISTANT VALVES (303 STAINLESS ST.) DIRECT OPERATED



Process

303 STAINLESS ST.

PIPE MOUNTING

NORMALLY CLOSED

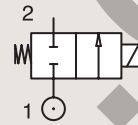

Port size	Orifice Ø	Flow factors			Operating Pressure Differential			Fluid Temp.		Seat Seal	Valve Ref.	Housing Ref.	Coil Ref.	IS	Power		Coil Group	Dwg. No.
		Kv l/min	KV m³/h	Qn m³/h	Min bar	Max(MOPD) AC bar	DC bar	Min °C	Max °C						AC W	DC W		
1/4"	1.5	1.5	0.09	80	0	20	20	-10	100	FKM	121V5406	2995	481865		8	9	2.0	8116
	1.5	1.5	0.09	80	0	20	20	-10	120	FKM	121V5406	4270	481000		8	8	2.0	8116
	1.5	1.5	0.09	80	0	60	25	0	100	Ruby	121V5463 ₁	2995	481865		8	9	2.0	8116
	1.5	1.5	0.09	80	0	75	30	0	130	Ruby	121V5463 ₁	4270	481000		8	8	2.0	8116
	1.5	1.5	0.09	80	0	100	55	0	140	Ruby	121V5463 ₁	4270	486265		14	14	2.0	8116
	1.5	1.5	0.09	80	0	-	8	-20	75	PUR	121V5497 ₂	2995	482740		-	1.6	6.0/8.0	8116
	1.5	1.5	0.09	80	0	10	10	-20	75	PUR	121V5497 ₂	-	495900		2.5	2	6.0/8.0	8024
	1.5	1.5	0.09	80	0	-	10	-20	75	PUR	121V5497 ₂	-	495910	*	-	0.3-1.2	6.0/8.0	8024
	1.5	1.5	0.09	80	0	-	8	-20	65	PUR	121V5497 ₂	2995	496125		-	1.6	6.0/8.0	8116
	2.5	3.5	0.21	220	0	14	7	-10	100	FKM	121V5706	2995	481865		8	9	2.0	8116
	2.5	3.5	0.21	220	0	14	9	-10	120	FKM	121V5706	4270	481000		8	8	2.0	8116
	2.5	3.5	0.21	220	0	14	14	-10	120	FKM	121V5706	4270	486265		14	14	2.0	8116
	2.5	3.5	0.21	220	0	28	10	0	100	Ruby	121V5763 ₁	2995	481865		8	9	2.0	8116
	2.5	3.5	0.21	220	0	34	12	0	130	Ruby	121V5763 ₁	4270	481000		8	8	2.0	8116
	2.5	3.5	0.21	220	0	50	22	0	140	Ruby	121V5763 ₁	4270	486265		14	14	2.0	8116
	3	4.5	0.27	315	0	10	7	-10	100	FKM	121V5306	2995	481865		8	9	2.0	8116
	3	4.5	0.27	315	0	10	8.5	-10	120	FKM	121V5306	4270	481000		8	8	2.0	8116
	3	4.5	0.27	315	0	10	10	-10	120	FKM	121V5306	4270	486265		14	14	2.0	8116
	3	4.5	0.27	315	0	20	7	0	100	Ruby	121V5363 ₁	2995	481865		8	9	2.0	8116
	3	4.5	0.27	315	0	25	8.5	0	130	Ruby	121V5363 ₁	4270	481000		8	8	2.0	8116
3	4.5	0.27	315	0	36	15	0	140	Ruby	121V5363 ₁	4270	486265		14	14	2.0	8116	

Notes:

- 1.Valve only compatible with hydraulic oil and neutral liquids
- 2.If media is water, the fluid temperature shall not exceed 40°C.



For this page	Port size	Orifice (mm)	Kv (l/min)	MOPD (bar)	Fluid Temp (°C)
From	1/4"	1.5	1.5	7	-20
To	1/4"	3	4.5	100	140

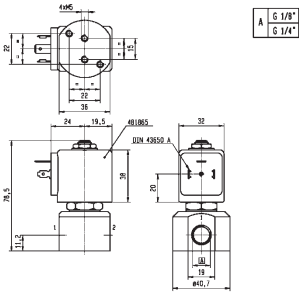

Drawing 8116

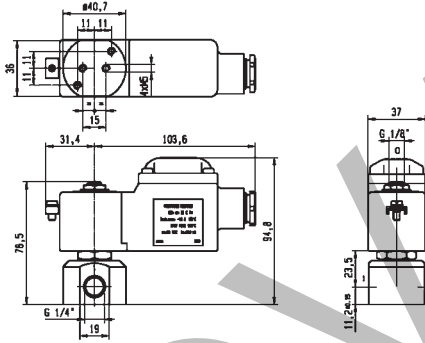

Drawing 8024

2/2

HIGH CORROSION RESISTANT VALVES (303 STAINLESS ST.) DIRECT OPERATED

303 STAINLESS ST.

PIPE MOUNTING

NORMALLY CLOSED

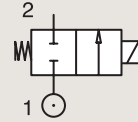

Port size	Orifice Ø	Flow factors			Operating Pressure Differential			Fluid Temp.		Seat Seal	Valve Ref.	Housing Ref.	Coil Ref.	IS	Power		Coil Group	Dwg. No.
		Kv l/min	KV m³/h	Qn m³/h	Min bar	Max(MOPD) AC bar	DC bar	Min °C	Max °C						AC W	DC W		
1/4"	3	3.5	0.21	220	0	-	2	-20	75	PUR	121V5397 ₂	2995	482740	-	1.6	6.0/8.0	8116	
	3	3.5	0.21	220	0	4.5	4	-20	75	PUR	121V5397 ₂	-	495900	2.5	2	6.0/8.0	8024	
	3	3.5	0.21	220	0	-	4.5	-20	75	PUR	121V5397 ₂	-	495910	*	0.3-1.2	6.0/8.0	8024	
	3	3.5	0.21	220	0	-	2	-20	65	PUR	121V5397 ₂	2995	496125	-	1.6	6.0/8.0	8116	
	4	7	0.42	450	0	10	4	-10	100	FKM	121V5206	2995	481865	8	9	2.0	8116	
	4	7	0.42	450	0	10	5	-10	120	FKM	121V5206	4270	481000	8	8	2.0	8116	
	4	7	0.42	450	0	10	10	-10	120	FKM	121V5206	4270	486265	14	14	2.0	8116	
	4	7	0.42	450	0	3.5	3.5	0	100	PTFE	121V5212 ₁	2995	481865	8	9	2.0	8116	
	4	7	0.42	450	0	3.5	3.5	0	130	PTFE	121V5212 ₁	4270	481000	8	8	2.0	8116	
	4	7	0.42	450	0	3.5	3.5	0	130	PTFE	121V5212 ₁	4270	486265	14	14	2.0	8116	
	4	7	0.42	450	0	12	4	0	100	Ruby	121V5263 ₁	2995	481865	8	9	2.0	8116	
	4	7	0.42	450	0	15	5	0	130	Ruby	121V5263 ₁	4270	481000	8	8	2.0	8116	
	4	7	0.42	450	0	22	10	0	180	Ruby	121V5263 ₁	4270	486265	14	14	2.0	8116	
	5	10	0.6	750	0	7	2	-10	100	FKM	121V5106	2995	481865	8	9	2.0	8116	
	5	10	0.6	750	0	7	2.8	-10	120	FKM	121V5106	4270	481000	8	8	2.0	8116	
	5	10	0.6	750	0	7	5	-10	120	FKM	121V5106	4270	486265	14	14	2.0	8116	
	5	10	0.6	-	0	2.8	2	0	100	PTFE	121V5112 ₁	2995	481865	8	9	2.0	8116	
	5	10	0.6	-	0	2.8	2.8	0	130	PTFE	121V5112 ₁	4270	481000	8	8	2.0	8116	
	5	10	0.6	-	0	2.8	2.8	0	130	PTFE	121V5112 ₁	4270	486265	14	14	2.0	8116	
	5	10	0.6	750	0	8.5	2	0	100	Ruby	121V5163 ₁	2995	481865	8	9	2.0	8116	
5	10	0.6	750	0	10	3.5	0	130	Ruby	121V5163 ₁	4270	481000	8	8	2.0	8116		
5	10	0.6	750	0	14	6.5	0	140	Ruby	121V5163 ₁	4270	486265	14	14	2.0	8116		
1/4" NPT	3	4.5	0.27	315	0	10	7	-10	100	FKM	U121V5306	2995	481865	8	9	2.0	8116	
	3	4.5	0.27	315	0	20	7	0	100	Ruby	U121V5363	2995	481865	8	9	2.0	8116	

Notes:

1. Valve only compatible with hydraulic oil and neutral liquids
2. Valve compatible with water only up to If fluid is water, temperature shall not exceed 40°C



For this page	Port size	Orifice (mm)	Kv (l/min)	MOPD (bar)	Fluid Temp (°C)
From	1/4"	3	3.5	2	-20
To	1/4"	5	10	22	180

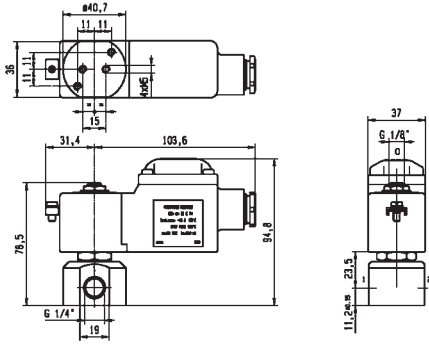

Drawing 8024

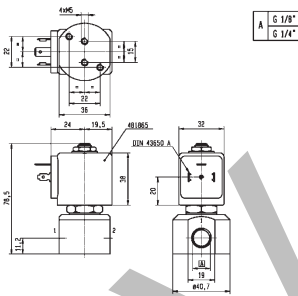

Drawing 8116

2/2

HIGH CORROSION RESISTANT VALVES (303 STAINLESS ST.) DIRECT OPERATED

303 STAINLESS ST.

PIPE MOUNTING

NORMALLY OPEN

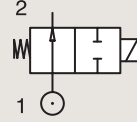

Port size	Orifice Ø	Flow factors			Operating Pressure Differential			Fluid Temp.		Seat Seal	Valve Ref.	Housing Ref.	Coil Ref.	Power		Coil Group	Dwg. No.
		Kv l/min	KV m³/h	Qn l/min	Min bar	Max(MOPD) AC bar	DC bar	Min °C	Max °C					AC W	DC W		
1/4"	2.5	3	0.18	180	0	12	12	-30	100	FKM	122V8306	2995	481865	8	9	2.1	8116
	2.5	3	0.18	180	0	12	12	-30	120	FKM	122V8306	4270	481000	8	8	2.1	8116

KONVARI



For this page	Port size	Orifice (mm)	Kv (l/min)	MOPD (bar)	Fluid Temp (°C)
From	1/4"	2.5	3	12	-30
To	1/4"	2.5	3	12	120

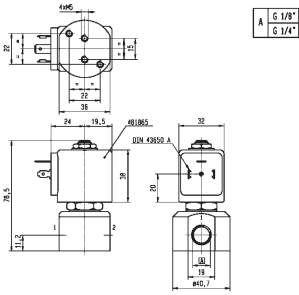

Drawing 8116

KOLVAR.COM

VALVES FOR BEVERAGE DISPENSING AND LIQUIPURE®



2/2

Actuation	Body	Function	Port Size	Orifice (mm)	Flow Factor Kv(l/min)	MOPD (bar)	Max Fluid Temp. (°C)	Page Parker Valves
Direct Operated	LLB Brass/Pipe Mounting	Normally Closed	1/8"	1.0 to 3	0.7 a 4.5	20	140	136
	LLB Brass/Pipe Mounting	Normally Closed	1/4"	1.5 to 5	1.5 a 9.5	20	140	138
	LLB Brass/Sub-base Mounting	Normally Closed	SB	1.5 to 3	1.4 a 3.4	20	140	138
	Stainless St./Sub-base Mounting	Normally Closed	SB	1.5 to 3	4.2	20	140	140

KOVAV

2/2

VALVES FOR BEVERAGE DISPENSING AND LIQUIPURE® DIRECT OPERATED

CW510L BRASS BODY
PIPE MOUNTING

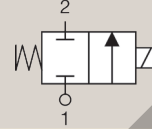

NORMALLY CLOSED

Port Size	Orifice Ø mm	Flow Factors		Operating Pressure Differential			Fluid Temperature		Seat Seal	Parker Valves			Power		Coil Group	Dwg N°
		Kv	KV	Min. Bar	Max. (MOPD) AC bar	DC bar	Min. °C	Max. °C		Valve Ref.	Housing Ref.	Coil Ref.	AC W	DC W		
G1/8"	1.0	0.7	0.04	0	20	18	-10	140	FDA	121ZH1010	2995	481865	9	8	2.0, 2.1, 2.2	1
	1.5	1.5	0.09	0	20	18	-10	140	FDA	121ZH1015	2995	481865	9	8	2.0, 2.1, 2.2	
	2.0	2.6	0.16	0	20	15	-10	140	FDA	121ZH1020	2995	481865	9	8	2.0, 2.1, 2.2	
	2.5	3.5	0.21	0	19	14.5	-10	140	FDA	121ZH1025	2995	481865	9	8	2.0, 2.1, 2.2	
	3.0	4.5	0.27	0	13	8.5	-10	140	FDA	121ZH1030	2995	481865	9	8	2.0, 2.1, 2.2	
	1.0	0.7	0.04	0	20	18	-10	140	Ruby	121ZH0010	2995	481865	9	8	2.0, 2.1, 2.2	
	1.5	1.5	0.09	0	20	18	-10	140	Ruby	121ZH0015	2995	481865	9	8	2.0, 2.1, 2.2	
	2.0	2.6	0.16	0	20	15	-10	140	Ruby	121ZH0020	2995	481865	9	8	2.0, 2.1, 2.2	
	2.5	3.5	0.21	0	19	14.5	-10	140	Ruby	121ZH0025	2995	481865	9	8	2.0, 2.1, 2.2	
	3.0	4.5	0.27	0	13	8.5	-10	140	Ruby	121ZH0030	2995	481865	9	8	2.0, 2.1, 2.2	
NPT 1/8"	1.0	0.7	0.04	0	20	18	-10	140	FDA	U121ZH1010	2995	481865	9	8	2.0, 2.1, 2.2	
	1.5	1.5	0.09	0	20	18	-10	140	FDA	U121ZH1015	2995	481865	9	8	2.0, 2.1, 2.2	
	2.0	2.6	0.16	0	20	15	-10	140	FDA	U121ZH1020	2995	481865	9	8	2.0, 2.1, 2.2	
	2.5	3.5	0.21	0	19	14.5	-10	140	FDA	U121ZH1025	2995	481865	9	8	2.0, 2.1, 2.2	
	3.0	4.5	0.27	0	13	8.5	-10	140	FDA	U121ZH1030	2995	481865	9	8	2.0, 2.1, 2.2	
	1.0	0.7	0.04	0	20	18	-10	140	Ruby	U121ZH0010	2995	481865	9	8	2.0, 2.1, 2.2	
	1.5	1.5	0.09	0	20	18	-10	140	Ruby	U121ZH0015	2995	481865	9	8	2.0, 2.1, 2.2	
	2.0	2.6	0.16	0	20	15	-10	140	Ruby	U121ZH0020	2995	481865	9	8	2.0, 2.1, 2.2	
	2.5	3.5	0.21	0	19	14.5	-10	140	Ruby	U121ZH0025	2995	481865	9	8	2.0, 2.1, 2.2	
	3.0	4.5	0.27	0	13	8.5	-10	140	Ruby	U121ZH0030	2995	481865	9	8	2.0, 2.1, 2.2	



For this page	Port size	Orifice (mm)	Kv (l/min)	MOPD (bar)	Fluid Temp (°C)
From	1/8"	1.5	1.5	2	-10
To	1/4"	4	9.5	20	140
From	SB	1.5	1.4	10	-10
To	SB	3	3.4	20	140

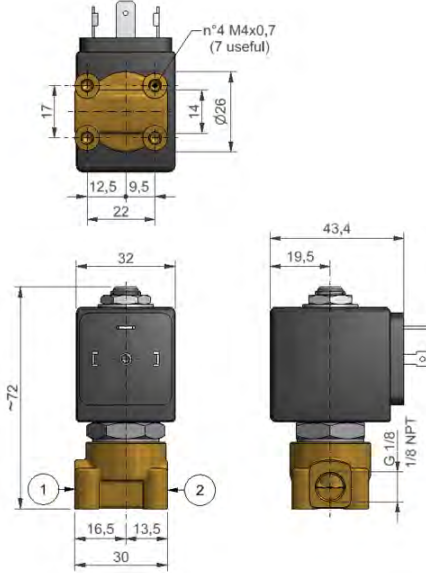

Drawing 1

2/2

VALVES FOR BEVERAGE DISPENSING AND LIQUIPURE® DIRECT OPERATED

CW510L BRASS BODY
PIPE MOUNTING FLANGED (SB)

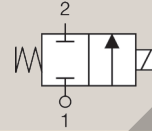

NORMALLY CLOSED

Port Size	Orifice Ø mm	Flow Factors		Operating Pressure Differential			Fluid Temperature		Seat Seal	Parker Valves			Power		Coil Group	Dwg N°	
		Kv	KV	Min. Bar	Max. (MOPD) AC bar	DC bar	Min. °C	Max. °C		Valve Ref.	Housing Ref.	Coil Ref.	AC W	DC W			
G1/4"	1.5	1.5	0.09	0	20	18	-10	140	FDA FKM	121KH1015	2995	481865	9	8	2.0, 2.1, 2.2	1	
	2.0	2.6	0.16	0	20	15	-10	140	FDA FKM	121KH1020	2995	481865	9	8	2.0, 2.1, 2.2		
	2.5	3.5	0.21	0	19	14.5	-10	140	FDA FKM	121KH1025	2995	481865	9	8	2.0, 2.1, 2.2		
	3.0	4.5	0.27	0	13	8.5	-10	140	FDA FKM	121KH1030	2995	481865	9	8	2.0, 2.1, 2.2		
	4.0	5.5	0.33	0	9	6	-10	140	FDA FKM	121KH1040	2995	481865	9	8	2.0, 2.1, 2.2		
	5.0	9.5	0.57	0	2.5	2	-10	140	FDA FKM	121KH1050	2995	481865	9	8	2.0, 2.1, 2.2		
SB	1.5	1.5	0.09	0	20	18	-10	140	Ruby	121KH0015	2995	481865	9	8	2.0, 2.1, 2.2	1	
	2.0	2.6	0.16	0	20	15	-10	140	Ruby	121KH0020	2995	481865	9	8	2.0, 2.1, 2.2		
	2.5	3.5	0.21	0	19	14.5	-10	140	Ruby	121KH0025	2995	481865	9	8	2.0, 2.1, 2.2		
	SB	3.0	4.5	0.27	0	13	8.5	-10	140	Ruby	121KH0030	2995	481865	9	8	2.0, 2.1, 2.2	3
		1.5	1.4	0.08	0	20	20	-10	140	FDA FKM	121FH1015	2995	481865	9	8	2.0, 2.1, 2.2	
		2.0	2.3	0.14	0	20	20	-10	140	FDA FKM	121FH1020	2995	481865	9	8	2.0, 2.1, 2.2	
		2.5	3.0	0.18	0	20	14	-10	140	FDA FKM	121FH1025	2995	481865	9	8	2.0, 2.1, 2.2	
		3.0	3.4	0.2	0	17	10	-10	140	FDA FKM	121FH1030	2995	481865	9	8	2.0, 2.1, 2.2	
		1.5	1.4	0.08	0	20	20	-10	140	Ruby	121FH0015	2995	481865	9	8	2.0, 2.1, 2.2	
		2.0	2.3	0.14	0	20	20	-10	140	Ruby	121FH0020	2995	481865	9	8	2.0, 2.1, 2.2	
		2.5	3.0	0.18	0	20	14	-10	140	Ruby	121FH0025	2995	481865	9	8	2.0, 2.1, 2.2	
		3.0	3.4	0.2	0	17	10	-10	140	Ruby	121FH0030	2995	481865	9	8	2.0, 2.1, 2.2	



For this page	Port size	Orifice (mm)	Kv (l/min)	MOPD (bar)	Fluid Temp (°C)
From	1/8"	1.5	1.5	2	-10
To	1/4"	4	9.5	20	140
From	SB	1.5	1.4	10	-10
To	SB	3	3.4	20	140

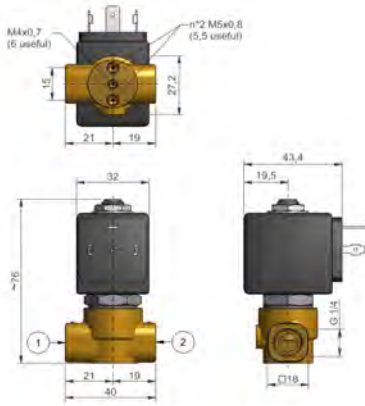

Drawing 1

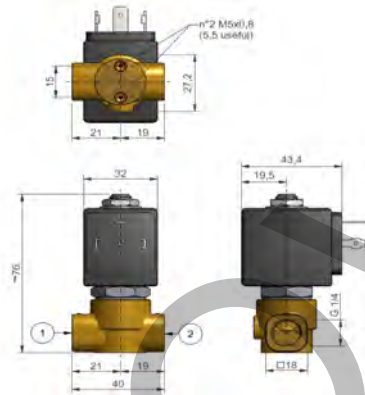

Drawing 2

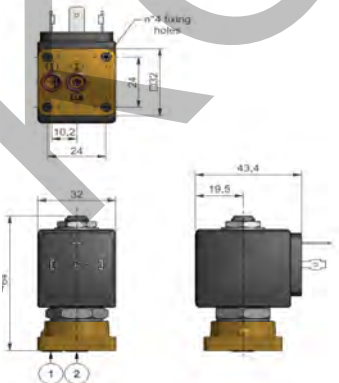

Drawing 3

2/2

VALVES FOR BEVERAGE DISPENSING -
LIQUIPURE®
DIRECT OPERATEDSTAINLESS ST.
SUB-BASE MOUNTING

NORMALLY CLOSED

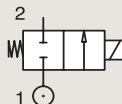

Port size	Orifice Ø				Flow factors			Operating Pressure Differential			Fluid Temp.		Seat Seal	Parker Valves			Power		Coil Group	Dwg. No.	Compatible adapter kit
	mm	Kv l/min	KV m ³ /h	Qn l/min	Min bar	Max(MOPD)		Min °C	Max °C	Valve Ref.	Housing Ref.	Coil Ref.		AC W	DC W						
						AC bar	DC bar														
SB	1.5	1.3	0.08	-	0	20	20	-10	140	Ruby	2019F1GRG7	-	481865	8	9	2.0	071	XGSPG1-XGSPG2			
	1.5	1.3	0.08	-	0	20	20	-10	140	FKM FDA	2019F1GVG7	-	481865	8	9	2.0	071	XGSPG1-XGSPG2			
	2	2.3	0.14	-	0	15	15	-10	140	Ruby	2019F1JRG7	-	481865	8	9	2.0	071	XGSPG1-XGSPG2			
	2	2.3	0.14	-	0	15	15	-10	140	FKM FDA	2019F1JVG7	-	481865	8	9	2.0	071	XGSPG1-XGSPG2			
	2.5	3.2	0.19	-	0	10	10	-10	140	FKM FDA	2019F1LRG7	-	481865	8	9	2.0	071	XGSPG1-XGSPG2			
	2.5	3.2	0.19	-	0	10	10	-10	140	FKM FDA	2019F1LVG7	-	481865	8	9	2.0	071	XGSPG1-XGSPG2			
	3	4.2	0.25	-	0	7	7	-10	140	Ruby	2019F1NRG7	-	481865	8	9	2.0	071	XGSPG1-XGSPG2			
	3	4.2	0.25	-	0	7	7	-10	140	FKM FDA	2019F1NVG7	-	481865	8	9	2.0	071	XGSPG1-XGSPG2			
	4	6.5	0.39	-	0	5	5	-10	140	FKM FDA	2019F1QVG7	-	481865	9	8	2.0	071	XGSPG3			
	4	6.5	0.39	-	0	5	5	-10	140	EPDM	2019F1QEG7	-	481865	9	8	2.0	071	XGSPG3			
	5	7.2	0.43	-	0	3	3	-10	140	FKM FDA	2019F1SVG7	-	481865	9	8	2.0	071	XGSPG3			
	5	7.2	0.43	-	0	3	3	-10	140	EPDM	2019F1SEG7	-	481865	9	8	2.0	071	XGSPG3			

Important: pressure vessels included in this page are supplied with the standard 2995 housing integrated.



For this page	Port size	Orifice (mm)	Kv (l/min)	MOPD (bar)	Fluid Temp (°C)
From	SB	1.5	1.3	3	-10
To	SB	5	7.2	20	140

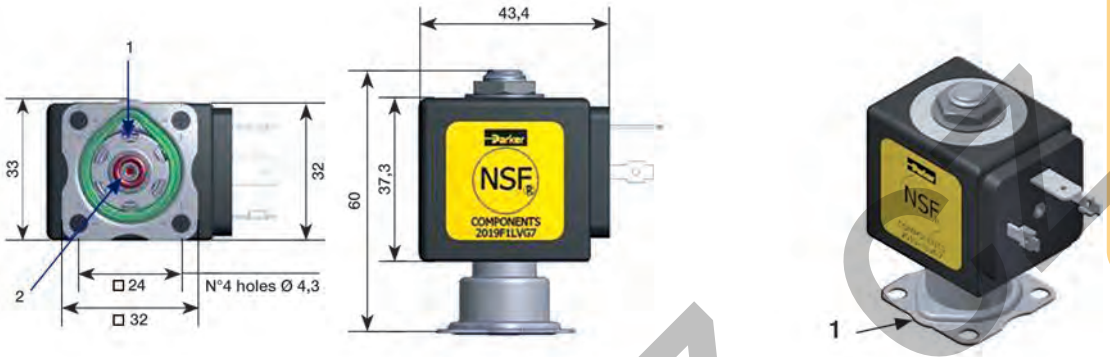

Drawing 071

KOVAR

HIGH CORROSION RESISTANT VALVES (316L STAINLESS ST.)



2/2

Actuation	Body	Function	Port Size	Orifice (mm)	Flow Factor Kv(l/min)	MOPD (bar)	Max Fluid Temp. (°C)	Page Parker Valves
Direct Operated	316L Stainless St./Pipe Mounting	Normally Closed	1/8"	1.5 to 2.5	2.3	20	140	144
			1/4"	1.5 to 3	6	20	140	144
		Normally Open	1/2"	3	10	4	140	144
			3/8"	5 to 6.2	10	4	140	144
			1/4"	1	0.6	98	75	148
Direct Operated	316L Stainless St./Pipe Mounting	Normally Open	1/4"	3.0 to 5	8	6	140	146
			1/2"	5.0 to 6.2	10	3	140	146
Magnalift	316L Stainless St./Pipe Mounting	Normally Closed	3/8"	15	65	20	140	150
			1/2"	15	80	20	140	150
			3/4"	15	80	20	140	152
			1"	25	160	16	120	152

2/2

HIGH CORROSION RESISTANT VALVES

201LG SERIES

DIRECT OPERATED

316L STAINLESS ST.
PIPE MOUNTING

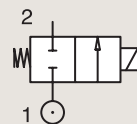

NORMALLY CLOSED

Port size	Orifice Ø	Flow factors			Operating Pressure Differential Max(MOPD)			Fluid Temp.		Seat Seal	Valve Ref.	Housing Ref.	Coil Ref.	Power		Coil Group	Dwg. No.
		Kv l/min	KV m ³ /h	Qn l/min	Min bar	AC bar	DC bar	Min °C	Max °C					AC W	DC W		
1/8"	1.5	1	0.06	-	0	20	15	-10	140	FKM	201LG1GVG2	-	481180	4	5	1.1/1.3	074
	2.5	2.3	0.14	-	0	10	6	-10	140	FKM	201LG1LVG2	-	481180	4	5	1.1/1.3	074
1/4"	1.5	1	0.06	-	0	20	15	-10	140	FKM	201LG2GVG2	-	481180	4	5	1.1/1.3	075
	2.5	2.3	0.14	-	0	10	6	-10	140	FKM	201LG2LVG2	-	481180	4	5	1.1/1.3	075
3/8"	3	4.5	0.27	-	0	8	5	-10	140	FKM	201LG2NVG7	-	481865	8	9	2.0	076
	5	8	0.48	-	0	3	2	-10	140	FKM	201LG3SVG7	-	481865	8	9	2.0	077
	6.2	10	0.6	-	0	1.5	0.5	-10	140	FKM	201LG3UVG7	-	481865	8	9	2.0	077
1/2"	5	8	0.48	-	0	3	2	-10	140	FKM	201LG4SVG7	-	481865	8	9	2.0	078
	6.2	10	0.6	-	0	1.5	0.5	-10	140	FKM	201LG4UVG7	-	481865	8	9	2.0	078

2 WAY VALVES



For this page	Port size	Orifice (mm)	Kv (l/min)	MOPD (bar)	Fluid Temp (°C)
From	1/8"	1.5	1	5	-10
To	1/2"	6.2	10	20	140

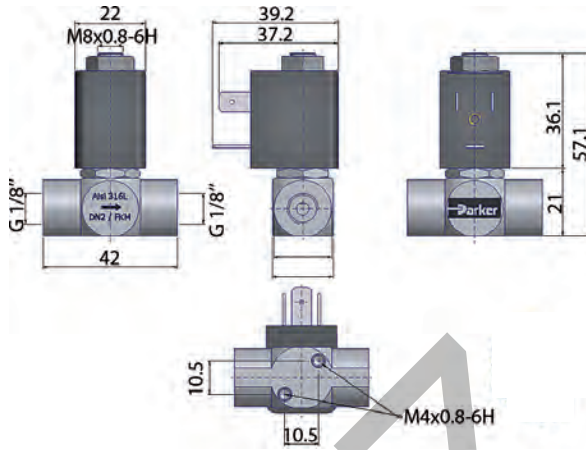

Drawing 074

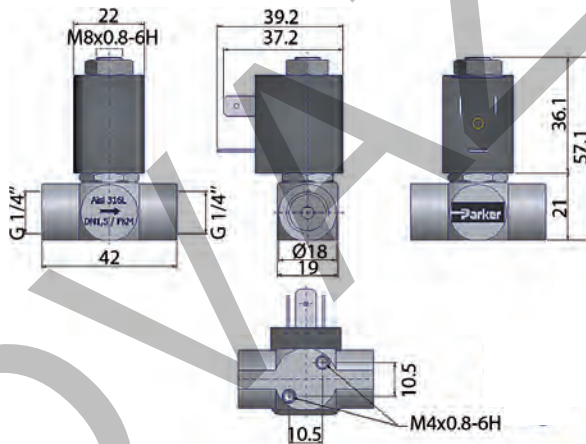

Drawing 075

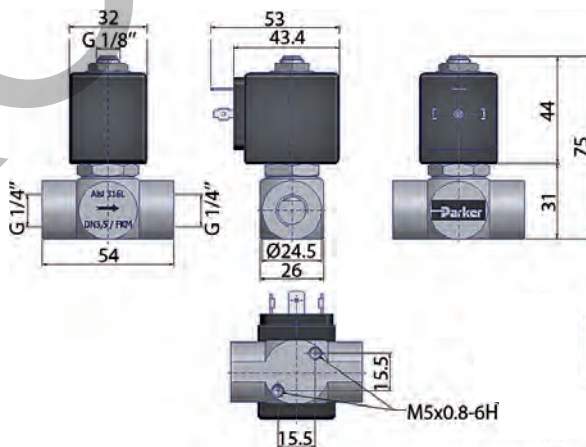

Drawing 076

2/2

HIGH CORROSION RESISTANT VALVES 202LG SERIES DIRECT OPERATED

316L STAINLESS ST.
PIPE MOUNTING

NORMALLY OPEN

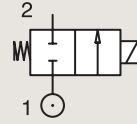

Port size	Orifice Ø	Flow factors		Operating Pressure Differential			Fluid Temp.		Seat Seal	Valve Ref.	Coil Ref.	Power		Coil Group	Dwg. No.
		Kv l/min	KV m³/h	Min bar	Max(MOPD) AC bar	DC bar	Min °C	Max °C				AC W	DC W		
1/4"	3.0	4.5	0.27	0	6	6	-10	140	FKM	202LG2NVG7	481865	8	9	24/2.0	3
	5.0	8.0	0.48	0	3	3	-10	140	FKM	202LG2SVG7	481865	8	9	24/2.0	3
1/2"	5.0	8.0	0.48	0	3	3	-10	140	FKM	202LG4SVG7	481865	8	9	24/2.0	3
	6.2	10.0	0.60	0	1	1	-10	140	FKM	202LG4UVG7	481865	8	9	24/2.0	3

KONVA



For this page	Port size	Orifice (mm)	Kv (l/min)	MOPD (bar)	Fluid Temp (°C)
From	1/4"	3	4.5	1	-10
To	1/2"	6.2	10	6	140

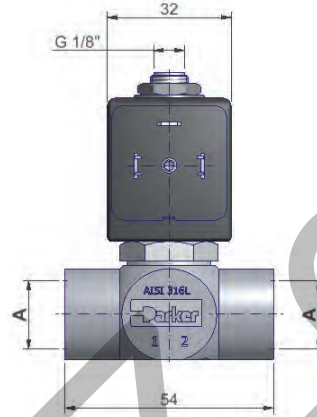
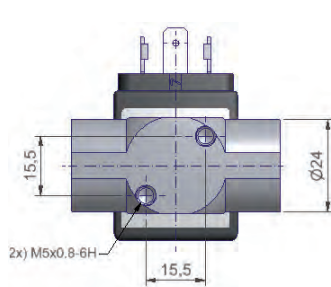

Drawing 3

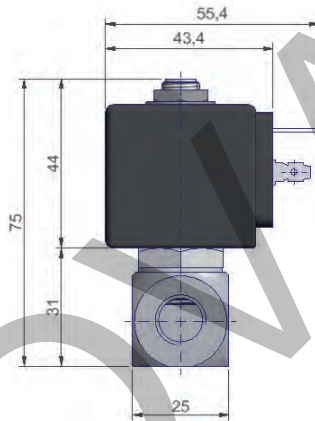

Drawing 3

2/2

HIGH CORROSION RESISTANT VALVES

V SERIES

DIRECT OPERATED

316L STAINLESS ST.

PIPE MOUNTING

NORMALLY CLOSED

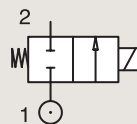

Port size	Orifice Ø mm	Flow factor			Operating Pressure Differential			Fluid Temp.		Seat Seal	Valve Ref.	Housing Ref.	Coil Ref.	ATEX Zone	Protection Mode	Power		Coil Group	Dwg. No.
		Kv l/min m ² /h	KV l/min	Qn bar	Min bar	AC bar	DC bar	Min °C	Max °C							AC W	DC W		
1/4" NPT	0.8	-	-	20	0	-	200	-25	65	PUR	U121VS3750A ₁	-	496565	0-20	Ex ia IIC T4 to T6	-	0.3	9.0/10.1/10.2	8165
	0.8	-	-	20	0	-	200	-25	75	PUR	U121VS3750A ₁	-	492210	1-21	Ex eb mb IIC T5 to T6	-	1 to 1.8	9.0/10.1/10.2	6713
	0.8	-	-	20	0	200	200	-25	75	PUR	U121VS3750A ₁	-	492310	1-21	Ex mb II T4 to T5	6	6	9.0/10.1/10.2	6713
	0.8	-	-	20	0	200	200	-25	65	PUR	U121VS3750A ₁	-	496560	1-21	Ex db mb IIC T4	8	8	9.0/10.1/10.2	8165
	0.8	-	-	20	0	200	200	-25	65	PUR	U121VS3750A ₁	-	496800	1-21	Ex db mb IIC T4	8	8	9.0/10.1/10.2	8165
	1	0.6	0.04	40	0	-	98	-40	75	PUR	U121V5595 ₂₃	-	496565	0-20	Ex ia IIC T4 to T6	-	0.3	9.0/10.1/10.2	8165
	1	0.6	0.04	40	0	-	98	-40	75	PUR	U121V5595 ₂₃	-	492210	1-21	Ex eb mb IIC T5 to T6	-	1 to 1.8	9.0/10.1/10.2	6713
	1	0.6	0.04	40	0	98	98	-40	65	PUR	U121V5595 ₂₃	-	496800	1-21	Ex db mb IIC T4	8	8	9.0/10.1/10.2	8165
	1	0.6	0.04	40	0	98	98	-40	75	PUR	U121V5595 ₂₃	-	492310	1-21	Ex mb II T4 to T5	6	6	9.0/10.1/10.2	6713
	1	0.6	0.04	40	0	98	98	-40	65	PUR	U121V5595 ₂₃	-	496560	1-21	Ex db mb IIC T4	8	8	9.0/10.1/10.2	8165
	1	0.6	0.04	40	0	98	98	-40	50	PUR	U121V5595 ₂₃	-	496895	-	-	8	8	9.0/10.1/10.2	8165
	1	0.6	0.04	40	0	-	98	-40	65	PUR	U121V7595 ₃	-	496565	0-20	Ex ia IIC T4 to T6	-	0.3	9.0/10.1/10.2/10.3	8165
	1	0.6	0.04	40	0	98	98	-40	65	PUR	U121V7595 ₃	-	496800	1-21	Ex db mb IIC T4	8	8	9.0/10.1/10.2/10.3	8165
	1	0.6	0.04	40	0	98	98	-40	65	PUR	U121V7595 ₃	-	497105	1-21	Ex db IIC T4 to T6	8	8	9.0/10.1/10.2/10.3	8299
1	0.6	0.04	40	0	98	98	-40	50	PUR	U121V7595 ₃	-	496895	-	-	8	8	9.0/10.1/10.2/10.3	8165	

Notes:

1. Valve only compatible with neutral gases
2. Valve delivered with an individual material traceability certificate (2.2 following EN10204)
3. Valve compatible with water only up to 40°C



For this page	Port size	Orifice (mm)	Kv (l/min)	MOPD (bar)	Fluid Temp (°C)
From	1/4"	1	0.6	98	-40
To	1/4"	1	0.6	98	75

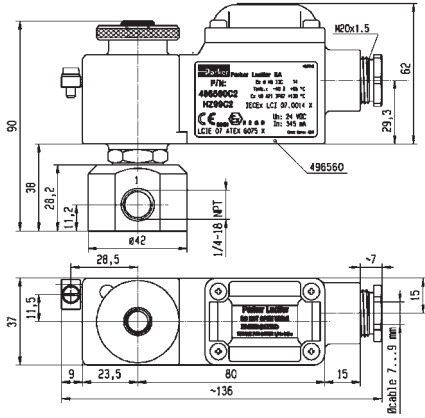

Drawing 8165

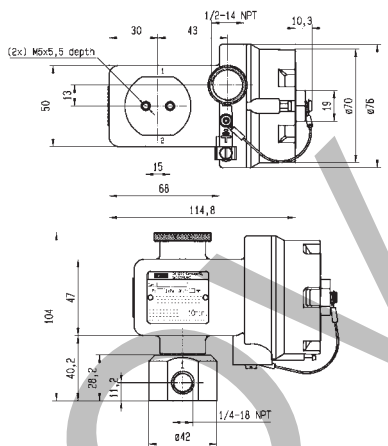

Drawing 8299

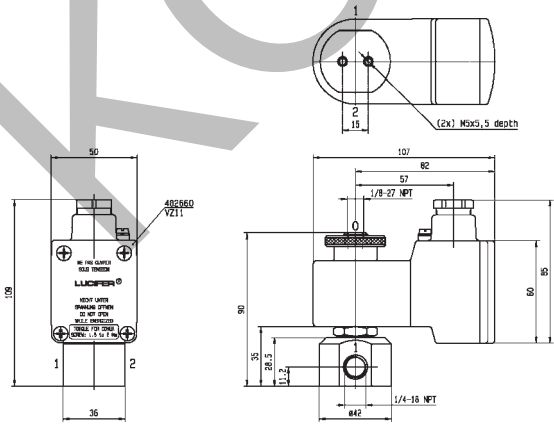

Drawing 6713

2/2

HIGH CORROSION RESISTANT VALVES
221G SERIES
MAGNALIFT

316L STAINLESS ST. - SILVER SHADIN RING

PIPE MOUNTING

NORMALLY CLOSED

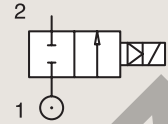

Port Size	Orifice Ø mm	Flow Factors		Operating Pressure Differential			Fluid Temperature		Seat Seal	Parker Valves			IS	ATEX Zone	Protection Mode		Power		Coil Group	Dwg N°
		Kv l/min	KV m³/h	Min. Bar	Max. (MOPD) AC bar	DC bar	Min. °C	Max. °C		Valve Ref.	Housing Ref.	Coil Ref.			Ex nAc nCc IIC T3/T4	Ex db mb IIC T4	AC W	DC W		
3/8"	15	65	3.90	0	16	-	-10	100	FKM	221G6306	2995	481865	-	-	-	8	-	2.0	3732	
	15	65	3.90	0	20	5	-10	100	FKM	221G6306	2995	492425	-	-	-	14	14	2.0	3732	
	15	65	3.90	0	16	-	-10	65	FKM	221G6306	2995	495870	-	2-22	Ex nAc nCc IIC T3/T4	8	-	2.0	3732	
	15	65	3.90	0	16	-	-10	120	FKM	221G6306	4270	481000	-	-	-	8	-	2.0	3732	
	15	65	3.90	0	20	7	-10	140	FKM	221G6306	4270	486265	-	-	-	14	14	2.0	3732	
	15	65	3.90	0	16	-	-10	80	FKM	221G6306	-	495905	-	1-21	Ex db mb IIC T4	8	-	2.0	3732	
	15	65	3.90	0	-	10	-10	100	FKM	221G6336 ₁	2995	481865	-	-	-	-	9	2.1	3732	
	15	65	3.90	0	-	10	-10	65	FKM	221G6336 ₁	2995	495870	-	2-22	Ex nAc nCc IIC T3/T4	-	9	2.1	3732	
	15	65	3.90	0	10	10	-10	65	FKM	221G6336 ₁	-	492070	-	1-21	Ex mb IIC T4/T5	9	8	2.1	3732	
	15	65	3.90	0	10	10	-10	75	FKM	221G6336 ₁	-	492190	-	1-21	Ex eb mb IIC T3/T4	11	9	2.1	3732	
	15	65	3.90	0	-	10	-10	80	FKM	221G6336 ₁	-	495905	-	1-21	Ex db mb IIC T4	-	8	2.1	3732	
	15	65	3.90	0	10	-	-10	100	EPDM	221G6307	2995	481865	-	-	-	8	-	2.0	3732	
	15	65	3.90	0	10	-	-10	65	EPDM	221G6307	2995	495870	-	2-22	Ex nAc nCc IIC T3/T4	8	-	2.0	3732	
	15	65	3.90	0	10	-	-10	120	EPDM	221G6307	4270	481000	-	-	-	8	-	2.0	3732	
	15	65	3.90	0	10	7	-10	140	EPDM	221G6307 ₂	4270	486265	-	-	-	14	14	2.0	3732	
1/2"	15	65	3.90	0	10	-	-10	80	EPDM	221G6307	-	495905	-	1-21	Ex db mb IIC T4	8	-	2.0	3732	
	15	80	4.80	0	16	-	-10	100	FKM	221G6506	2995	481865	-	-	-	8	-	2.0	3732	
	15	80	4.80	0	20	5	-10	100	FKM	221G6506	2995	492425	-	-	-	14	14	2.0	3732	
	15	80	4.80	0	16	-	-10	65	FKM	221G6506	2995	495870	-	2-22	Ex nAc nCc IIC T3/T4	8	-	2.0	3732	
	15	80	4.80	0	16	-	-10	120	FKM	221G6506	4270	481000	-	-	-	8	-	2.0	3732	
	15	80	4.80	0	20	7	-10	140	FKM	221G6506	4270	486265	-	-	-	14	14	2.0	3732	
	15	80	4.80	0	16	-	-10	80	FKM	221G6506	-	495905	-	1-21	Ex db mb IIC T4	8	-	2.0	3732	
	15	80	4.80	0	-	10	-10	100	FKM	221G6536 ₁	2995	481865	-	-	-	-	9	2.1	3732	
	15	80	4.80	0	-	10	-10	65	FKM	221G6536 ₁	2995	495870	-	2-22	Ex nAc nCc IIC T3/T4	-	9	2.1	3732	
	15	80	4.80	0	10	10	-10	65	FKM	221G6536 ₁	-	492070	-	1-21	Ex mb IIC T4/T5	9	8	2.1	3732	
	15	80	4.80	0	10	10	-10	75	FKM	221G6536 ₁	-	492190	-	1-21	Ex eb mb IIC T3/T4	11	9	2.1	3732	
	15	80	4.80	0	-	10	-10	80	FKM	221G6536 ₁	-	495905	-	1-21	Ex db mb IIC T4	-	8	2.1	3732	
	15	80	4.80	0	10	-	-10	100	EPDM	221G6507	2995	481865	-	-	-	8	-	2.0	3732	
	15	80	4.80	0	10	-	-10	65	EPDM	221G6507	2995	495870	-	2-22	Ex nAc nCc IIC T3/T4	8	-	2.0	3732	
	15	80	4.80	0	10	-	-10	120	EPDM	221G6507	4270	481000	-	-	-	8	-	2.0	3732	
15	80	4.80	0	10	7	-10	140	EPDM	221G6507 ₂	4270	486265	-	-	-	14	14	2.0	3732		
15	80	4.80	0	10	-	-10	80	EPDM	221G6507	-	495905	-	1-21	Ex db mb IIC T4	8	-	2.0	3732		

Notes:

- 1. Without shading ring
- 2. Maximum pressure for steam: 4 bar (140°C)



For this page	Port size	Orifice (mm)	Kv (l/min)	MOPD (bar)	Fluid Temp (°C)
From	3/8"	15	65	6	-10
To	1/2"	15	80	20	140

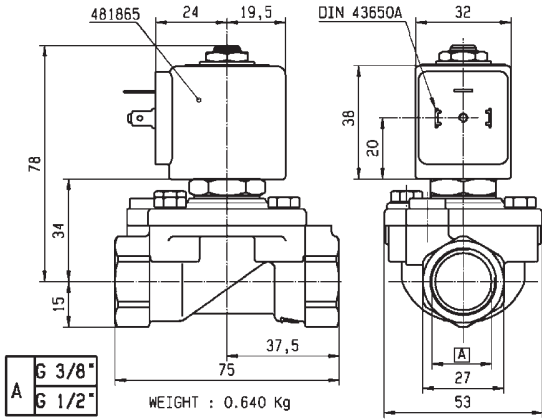

Drawing 3732

KOVALAN

2/2

HIGH CORROSION RESISTANT VALVES
221G SERIES
MAGNALIFT

316L STAINLESS ST. - SILVER SHADIN RING

PIPE MOUNTING

NORMALLY CLOSED

Port Size	Orifice Ø mm	Flow Factors		Operating Pressure Differential			Fluid Temperature		Seat Seal	Parker Valves			IS	ATEX Zone	Protection Mode	Power		Coil Group	Dwg N°
		Kv l/min	KV m³/h	Min. Bar	Max. (MOPD) AC bar	DC bar	Min. °C	Max. °C		Valve Ref.	Housing Ref.	Coil Ref.				AC W	DC W		
3/4"	15	80	4.80	0	16	-	-10	100	FKM	221G6606	2995	481865	-	-	-	8	-	2.0	8451
	15	80	4.80	0	20	5	-10	60	FKM	221G6606	2995	492425	-	-	-	14	14	2.0	8451
	15	80	4.80	0	16	-	-10	65	FKM	221G6606	2995	495870	-	2-22	Ex nAc nCc IIC T3/T4	8	-	2.0	8451
	15	80	4.80	0	16	-	-10	120	FKM	221G6606	4270	481000	-	-	-	8	-	2.0	8451
	15	80	4.80	0	20	7	-10	140	FKM	221G6606	4270	486265	-	-	-	14	14	2.0	8451
	15	80	4.80	0	16	-	-10	80	FKM	221G6606	-	495905	-	1-21	Ex db mb IIC T4	8	-	2.0	8451
	15	80	4.80	0	-	10	-10	100	FKM	221G6636 ₁	2995	481865	-	-	-	-	9	2.1	8451
	15	80	4.80	0	-	10	-10	65	FKM	221G6636 ₁	2995	495870	-	2-22	Ex nAc nCc IIC T3/T4	-	9	2.1	8451
	15	80	4.80	0	10	10	-10	65	FKM	221G6636 ₁	-	492070	-	1-21	Ex mb IIC T4/T5	9	8	2.1	8451
	15	80	4.80	0	10	10	-10	75	FKM	221G6636 ₁	-	492190	-	1-21	Ex eb mb IIC T3/T4	11	9	2.1	8451
	15	80	4.80	0	-	10	-10	80	FKM	221G6636 ₁	-	495905	-	1-21	Ex db mb IIC T4	-	8	2.1	8451
	15	80	4.80	0	10	-	-10	100	EPDM	221G6607	2995	481865	-	-	-	8	-	2.0	8451
	15	80	4.80	0	10	-	-10	65	EPDM	221G6607	2995	495870	-	2-22	Ex nAc nCc IIC T3/T4	8	-	2.0	8451
	15	80	4.80	0	10	-	-10	120	EPDM	221G6607	4270	481000	-	-	-	8	-	2.0	8451
	15	80	4.80	0	10	7	-10	140	EPDM	221G6607 ₂	4270	486265	-	-	-	14	14	2.0	8451
15	80	4.80	0	10	-	-10	80	EPDM	221G6607	-	495905	-	1-21	Ex db mb IIC T4	8	-	2.0	8451	
1"	25	160	9.60	0	16	-	-10	100	FKM	221G6106	2995	481865	-	-	-	8	-	2.0	3448
	25	160	9.60	0	20	5	-10	60	FKM	221G6106	2995	492425	-	-	-	14	14	2.0	3448
	25	160	9.60	0	16	-	-10	65	FKM	221G6106	2995	495870	-	2-22	Ex nAc nCc IIC T3/T4	8	-	2.0	3448
	25	160	9.60	0	16	6	-10	120	FKM	221G6106	4270	486265	-	-	-	14	14	2.0	3448
	25	160	9.60	0	16	-	-10	80	FKM	221G6106	-	495905	-	1-21	Ex db mb IIC T4	8	-	2.0	3448
	25	160	9.60	0	-	10	-10	100	FKM	221G6136 ₁	2995	481865	-	-	-	-	9	2.0	3448
	25	160	9.60	0	-	10	-10	65	FKM	221G6136 ₁	2995	495870	-	2-22	Ex nAc nCc IIC T3/T4	-	9	2.0	3448
	25	160	9.60	0	-	10	-10	100	FKM	221G6136 ₁	4270	481000	-	-	-	-	8	2.0	3448
	25	160	9.60	0	-	10	-10	80	FKM	221G6136 ₁	-	495905	-	1-21	Ex db mb IIC T4	-	8	2.0	3448
	25	160	9.60	0	10	-	-10	100	EPDM	221G6107	2995	481865	-	-	-	8	---	2.0	8448
	25	160	9.60	0	10	-	-10	65	EPDM	221G6107	2995	495870	-	2-22	Ex nAc nCc IIC T3/T4	8	-	2.0	8448
	25	160	9.60	0	10	-	-10	120	EPDM	221G6107	4270	481000	-	-	-	8	---	2.0	8448
25	160	9.60	0	10	10	-10	140	EPDM	221G6107 ₂	4270	486265	-	-	-	14	14	2.0	8448	
25	160	9.60	0	10	-	-10	80	EPDM	221G6107	-	495905	-	1-21	Ex db mb IIC T4	8	-	2.0	8448	

Notes:

- Without shading ring
- Maximum pressure for steam: 4 bar (140°C)



For this page	Port size	Orifice (mm)	Kv (l/min)	MOPD (bar)	Fluid Temp (°C)
From	3/4"	15	80	6	-10
To	1"	25	160	20	140

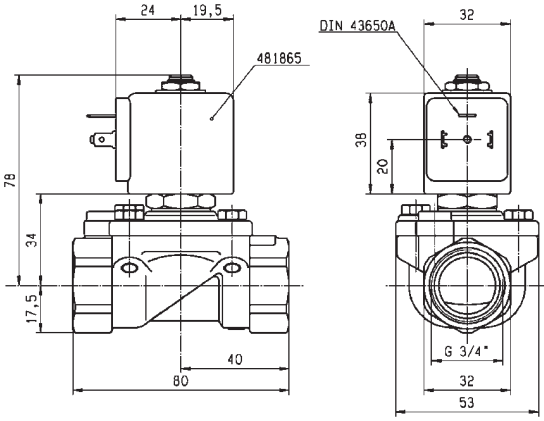

Drawing 8451

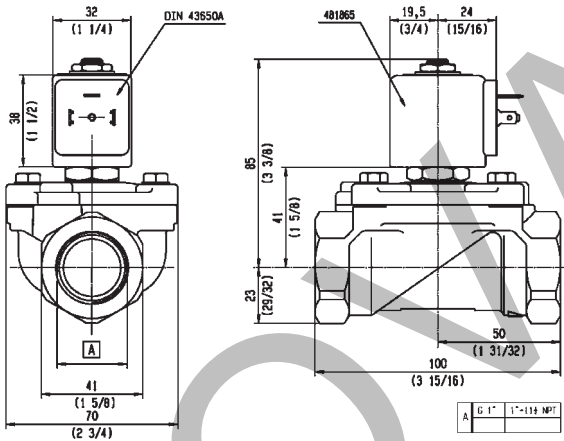

Drawing 8448

OIL BURNER VALVES



2/2

Actuation	Body	Function	Port Size	Orifice (mm)	Flow Factor Kv(l/min)	MOPD (bar)	Max Fluid Temp. (°C)	Page Parker Valves
Direct Operated	Brass/Pipe Mounting	Normally Closed	1/8"	3	4	30	160	156
			1/4"	3	4	30	160	156
			3/8"	6 to 11	22	30	160	156
	Brass/Pipe Mounting	Normally Open	1/2"	14	25	30	160	156
			1/8"	2.5	3.5	30	160	158
			1/4"	2.5	3.5	30	160	158
Magnalift Pilot Operated	Brass/Sub-base Mounting	Normally Closed	SB	2.5	3.5	30	160	158
	Brass/Pipe Mounting	Normally Closed	1/2"	15	50	5	140	160
			1/4"	8	36	40	140	162
Pilot Operated	Brass/Pipe Mounting	Normally Closed	3/8"	11	50	40	160	162
			1/2"	15	60	40	160	164
			14 mm	14	45	30	160	164

2/2

OIL BURNER VALVES

DIRECT OPERATED

BRASS

PIPE MOUNTING

NORMALLY CLOSED

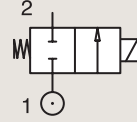

Port size	Orifice Ø	Flow factors			Operating Pressure Differential			Fluid Temp.		Seat Seal	Valve Ref.	Housing Ref.	Coil Ref.	Power		Coil Group	Dwg. No.
		Kv l/min	KV m³/h	Qn l/min	Min bar	Max(MOPD) AC bar	DC bar	Min °C	Max °C					AC W	DC W		
1/8"	2.2	2.8	0.17	-	0	25	-	-10	120	Ruby	121Z2323	299522	483764	9	-	14.2	7863
	3	4	0.24	-	0	30	-	-30	160	Ruby	121K2423	852023	483824	19	-	14.1	3292
1/4"	3	4.5	0.27	-	0	30	-	-30	160	Ruby	121K6423	852023	483824	19	-	14.1	3292
	4	6.5	0.39	-	0	30	-	0	160	Ruby	121K6220	852023	483541	20	-	14.3	3510
3/8"	6	12	0.72	-	0	5	-	0	120	Ruby	121K3321	2995	492425	14	-	14.1	3551
	11	22	1.32	-	0	30	-	0	160	FKM	121G2320	852023	483541	20	-	14.3	3646
1/2"	14	25	1.5	-	0	30	-	0	160	FKM	121G2520	852023	483541	20	-	14.3	3646
	14	25	1.5	-	0	30	-	0	160	FKM	121G2523	852023	483824	19	-	14.1	3646

Notes:

- 1. DIN-EN-ISO 23553-1:2014-09 approved for oil burners
- 2. Max. Static pressure = 30 bar; max pressure differential = 0.2 bar

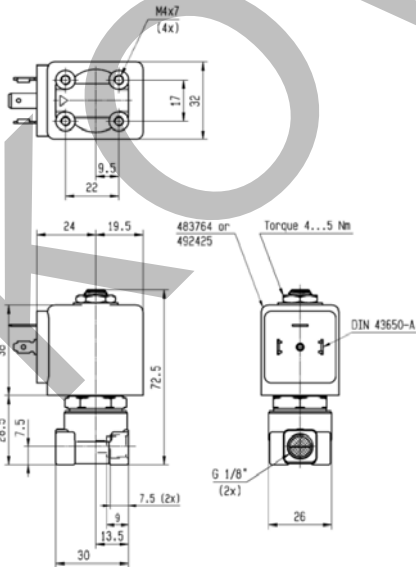

Drawing 7863



For this page	Port size	Orifice (mm)	Kv (l/min)	MOPD (bar)	Fluid Temp (°C)
From	1/8"	3	4	5	-30
To	1/2"	14	25	30	160

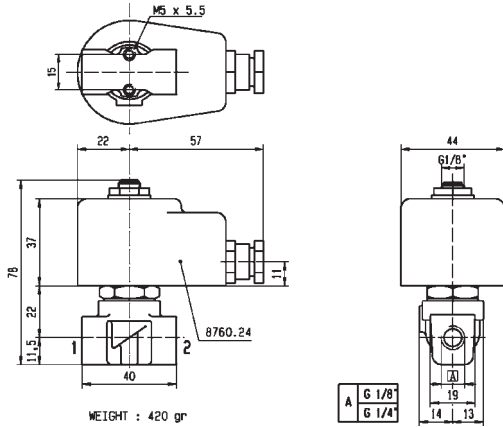

Drawing 3292

Valve	A
121823...	G 3/8"
121825...	G 1/2"

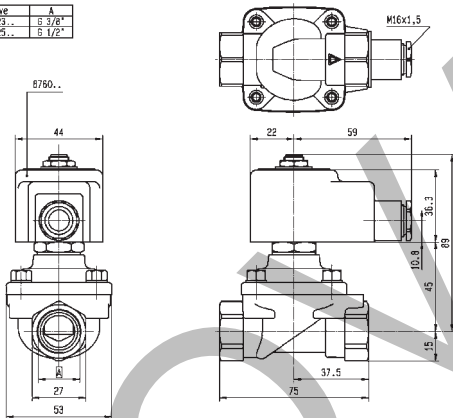

Drawing 3646

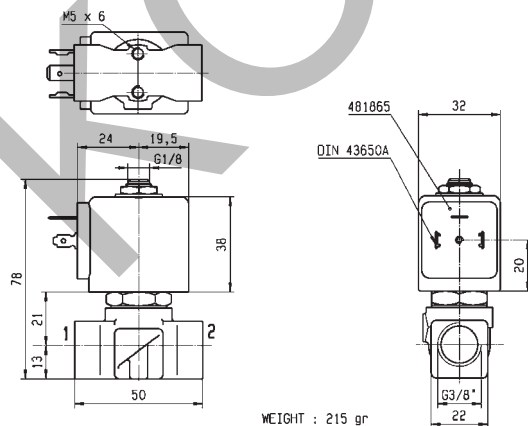

Drawing 3551

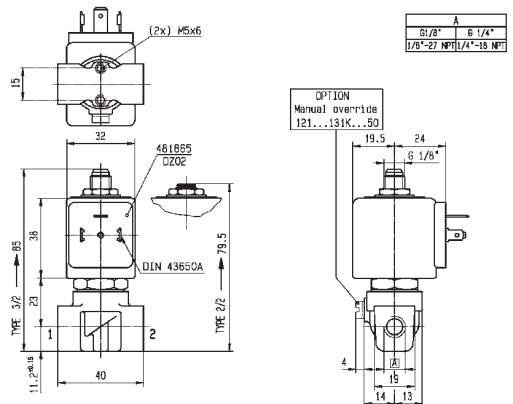

Drawing 3510

2/2

OIL BURNER VALVES

DIRECT OPERATED

BRASS

PIPE MOUNTING

NORMALLY OPEN

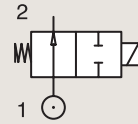

Port size	Orifice Ø	Flow factors			Operating Pressure Differential			Fluid Temp.		Seat Seal	Valve Ref.	Housing Ref.	Coil Ref.	Power		Coil Group	Dwg. No.
		Kv l/min	KV m³/h	Qn l/min	Min bar	Max(MOPD) AC bar	DC bar	Min °C	Max °C					AC W	DC W		
1/8"	2.5	3.5	0.21	-	0	30	-	-30	160	Ruby	122K9321	852023	483824	19	-	14.1	6766
1/4"	2.5	3.5	0.21	-	0	30	-	-30	160	Ruby	122K8321	852023	483824	19	-	14.1	6766

Notes:

1.DIN-EN-ISO 23553-1:2014-09 approved for oil burners

BRASS

SUB-BASE MOUNTING

NORMALLY CLOSED

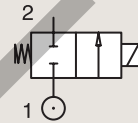

Port size	Orifice Ø	Flow factors			Operating Pressure Differential			Fluid Temp.		Seat Seal	Valve Ref.	Housing Ref.	Coil Ref.	Power		Coil Group	Dwg. No.
		Kv l/min	KV m³/h	Qn l/min	Min bar	Max(MOPD) AC bar	DC bar	Min °C	Max °C					AC W	DC W		
SB	14	25	1.5	-	0	30	-	0	160	FKM	121F2523	852023	483824	19	-	14.1	7638

Notes:

1.DIN-EN-ISO 23553-1:2014-09 approved for oil burners



For this page	Port size	Orifice (mm)	Kv (l/min)	MOPD (bar)	Fluid Temp (°C)
From	1/8"	2.5	3.5	30	-30
To	SB	14	25	30	160

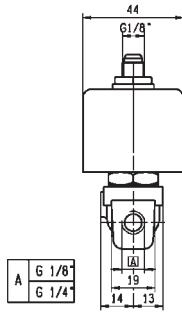
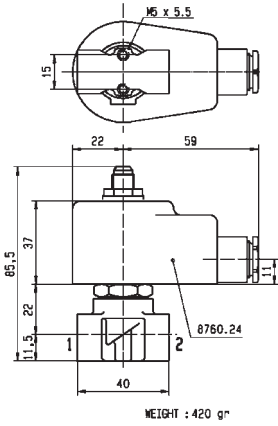

Drawing 6766

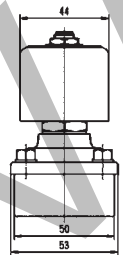
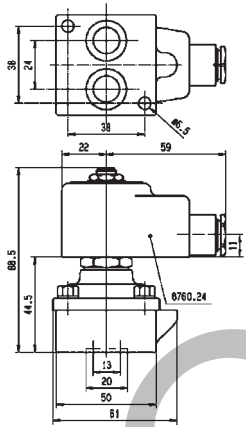

Drawing 7638

2/2

OIL BURNER VALVES

MAGNALIFT

BRASS

PIPE MOUNTING

NORMALLY CLOSED

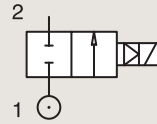

Port size	Orifice Ø	Flow factors			Operating Pressure Differential			Fluid Temp.		Seat Seal	Valve Ref.	Housing Ref.	Coil Ref.	Power		Coil Group	Dwg. No.
		Kv l/min	KV m³/h	Qn l/min	Min bar	Max(MOPD) AC bar	DC bar	Min °C	Max °C					AC W	DC W		
1/2"	15	50	3	-	0	5	-	0	140	FKM	221G2523	852023	483824	19	-	14.1	8298

Notes:

1.DIN-EN-ISO 23553-1:2014-09 approved for oil burners



For this page	Port size	Orifice (mm)	Kv (l/min)	MOPD (bar)	Fluid Temp (°C)
From	1/2"	15	50	5	0
To	1/2"	15	50	5	140

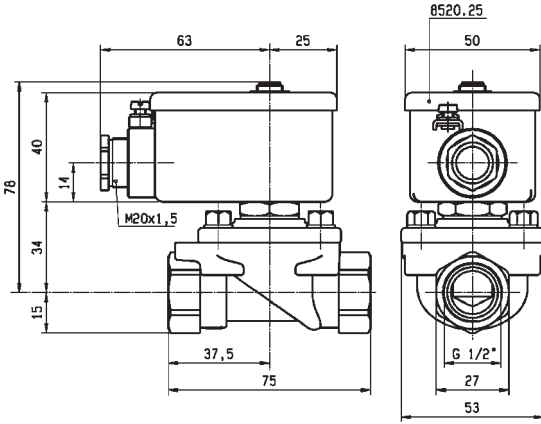

Drawing 8298

KOLVAN

2/2

OIL BURNER VALVES

PILOT OPERATED

BRASS

PIPE MOUNTING

NORMALLY CLOSED

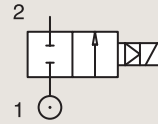

Port size	Orifice Ø	Flow factors			Operating Pressure Differential			Fluid Temp.		Seat Seal	Valve Ref.	Housing Ref.	Coil Ref.	Power		Coil Group	Dwg. No.
		Kv l/min	KV m³/h	Qn l/min	Min bar	Max(MOPD) AC bar	DC bar	Min °C	Max °C					AC W	DC W		
1/4"	8	36	2.16	-	0.3	40	25	-10	100	FKM	E321H21 ²³	2995	481865	8	9	2.0	3523
	8	36	2.16	-	0.3	40	30	-10	120	FKM	E321H21 ²³	4270	481000	8	8	2.0	3523
	8	36	2.16	-	0.3	40	40	-10	140	FKM	E321H21 ²³	4270	486265	14	14	2.0	3523
3/8"	11	40	2.4	-	0.3	30	-	0	160	Ruby	321H2322 ¹²	852023	483541	20	-	14.1	3633
	11	50	3	-	0.3	40	25	-10	100	FKM	E321H23 ²³	2995	481865	8	9	2.0	3521
	11	50	3	-	0.3	40	30	-10	120	FKM	E321H23 ²³	4270	481000	8	8	2.0	3521
	11	50	3	-	0.3	40	40	-10	140	FKM	E321H23 ²³	4270	486265	14	14	2.0	3521

Notes:

1. DIN-EN-ISO 23553-1:2014-09 approved for oil burners
2. Minimum pressure differential = 0.3 bar for opening and 0 bar for closing
3. Pilot seat disc in synthetic Ruby



For this page	Port size	Orifice (mm)	Kv (l/min)	MOPD (bar)	Fluid Temp (°C)
From	1/4"	8	36	25	-10
To	3/8"	11	50	40	160

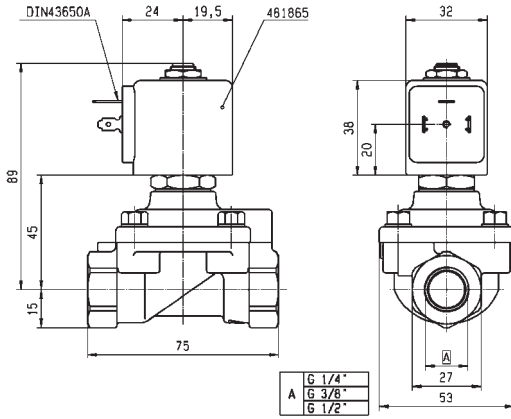

Drawing 3523

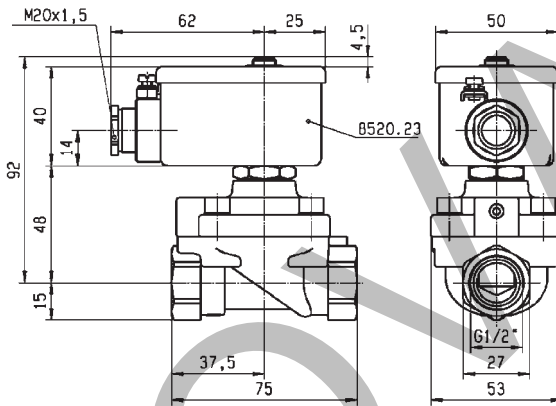

Drawing 3633

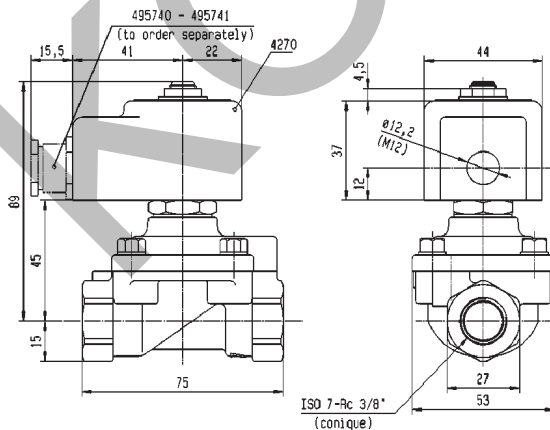

Drawing 3521

2/2

OIL BURNER VALVES

PILOT OPERATED

BRASS

PIPE MOUNTING

NORMALLY CLOSED

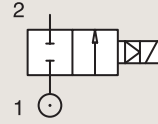

Port size	Orifice Ø	Flow factors			Operating Pressure Differential			Fluid Temp.		Seat Seal	Valve Ref.	Housing Ref.	Coil Ref.	Power		Coil Group	Dwg. No.
		Kv l/min	KV m³/h	Qn l/min	Min bar	Max(MOPD) AC bar	DC bar	Min °C	Max °C					AC W	DC W		
1/2"	15	60	3.6	-	0.3	30	-	0	160	Ruby	321H2522 ₁	852023	483541	20	-	14.1	3633
	15	60	3.6	-	0.3	30	-	0	160	Ruby	321H2523 ₁	852023	483824	19	-	14.1	3633
	15	60	3.6	-	0.3	40	25	-10	100	FKM	E321H25 ₂₃	2995	481865	8	9	2.0/14.2	3522
	15	60	3.6	-	0.3	40	30	-10	65	FKM	E321H25 ₂₃	-	483371	8	8	2.0/14.2	3522
	15	60	3.6	-	0.3	40	40	-10	140	FKM	E321H25 ₂₃	4270	486265	14	14	2.0/14.2	3522

Notes:

- 1.DIN-EN-ISO 23553-1:2014-09 approved for oil burners burners
- 2.Minimum pressure differential = 0.3 bar for opening and 0 bar for closing
- 3.Pilot seat disc in synthetic Ruby

BRASS

SUB-BASE MOUNTING

NORMALLY CLOSED

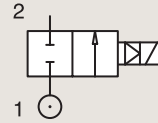

Port size	Orifice Ø	Flow factors			Operating Pressure Differential			Fluid Temp.		Seat Seal	Valve Ref.	Housing Ref.	Coil Ref.	Power		Coil Group	Dwg. No.
		Kv l/min	KV m³/h	Qn l/min	Min bar	Max(MOPD) AC bar	DC bar	Min °C	Max °C					AC W	DC W		
SB	14	45	2.7	-	0	30	-	0	160	FKM	321F2523 ₁₂	852023	483824	19	-	14.1	7639

Notes:

- 1.DIN-EN-ISO 23553-1:2014-09 approved for oil burners
- 2.Minimum pressure differential = 0.3 bar for opening and 0 bar for closing



For this page	Port size	Orifice (mm)	Kv (l/min)	MOPD (bar)	Fluid Temp (°C)
From	1/2"	14	45	25	-10
To	14 mm	15	60	40	160

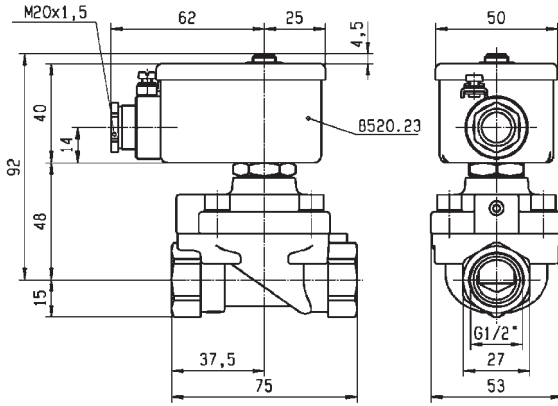

Drawing 3633

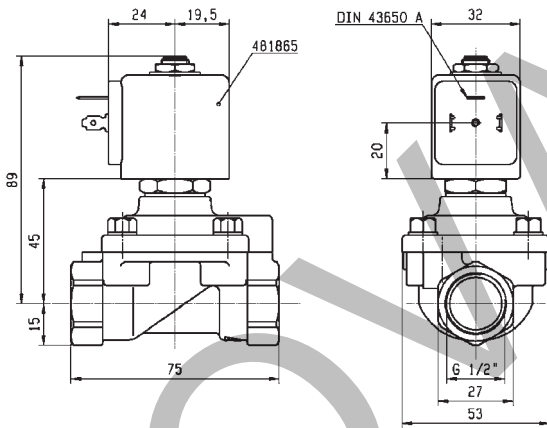

Drawing 3522

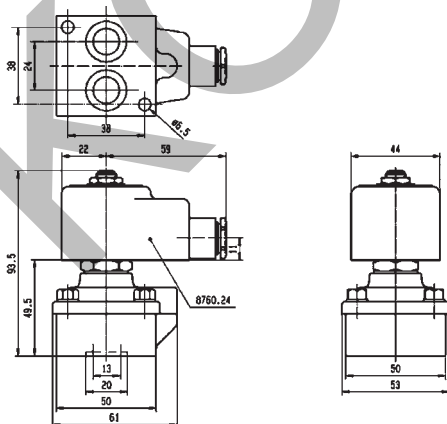

Drawing 7639

FAST SWITCHING VALVES



Air

2/2

Actuation	Body	Function	Port Size	Orifice (mm)	Flow Factor Kv(l/min)	MOPD (bar)	Max Fluid Temp. (°C)	Page Parker Valves
Magnalift	Brass/Pipe Mounting	Normally Closed	3/8"	8	0	7	40	168

KOVALAN

2/2

FAST SWITCHING VALVES

MAGNALIFT

BRASS

PIPE MOUNTING

NORMALLY CLOSED

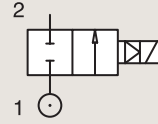

Port size	Orifice Ø	Flow factors			Operating Pressure Differential			Fluid Temp.		Seat Seal	Valve Ref.	Housing Ref.	Coil Ref.	Power		Coil Group	Dwg. No.
		Kv l/min	KV m³/h	Qn l/min	Min bar	Max(MOPD) AC bar	DC bar	Min °C	Max °C					AC W	DC W		
3/8"	8	-	-	-	0	-	7	0	40	PUR	221J3301E	29956	483816	-	14		8020

Notes:

1. For more details, please consult catalogue 8674UK

Flow rate (valve on 100%)

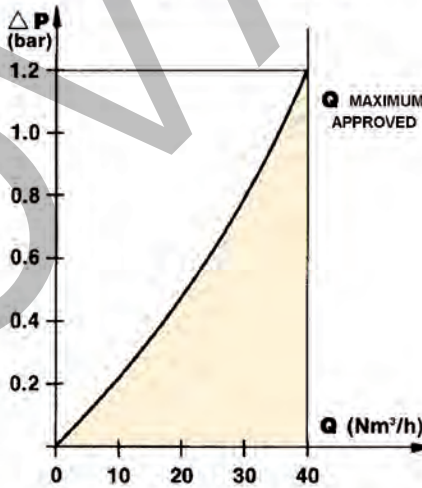



For this page	Port size	Orifice (mm)	Kv (l/min)	MOPD (bar)	Fluid Temp (°C)
From	3/8"	8	-	7	0
To	3/8"	8	-	7	40

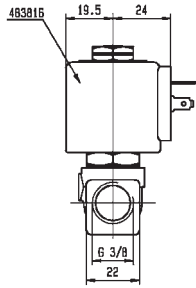
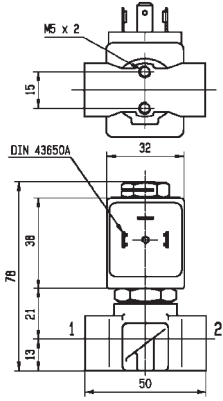

Drawing 8020

KOVAR



VALVES FOR DRY OR LUBRICATED AIR, NEUTRAL GASES AND LIQUIDS



3/2

Actuation	Body	Function	Port Size	Orifice (mm)	Flow Factor Kv(l/min)	MOPD (bar)	Max Fluid Temp. (°C)	Page Parker Valves
Direct Operated	Brass/Pipe Mounting	Normally Closed	1/8"	1.2 to 2.5	3.5	15	120	172
			1/4"	1 to 4.5	7	15	120	172 to 178
		Normally Open	1/4"	1.5 to 3	4.5	16	120	180
		Universal	1/8"	1.5 to 2.5	3.5	10	140	182
			1/4"	0.8 to 3	4.5	30	140	182 and 184
		Control by Electric Impulse	1/4"	1.5	1.5	16	100	184
	Brass/Sub-base Mounting	Normally Closed	SB	1 to 2.5	3.5	15	140	186 and 188
		Normally Open	SB	1.5 to 2.5	2.2	15	120	188
		Universal	SB	1.5 to 2.5	2.5	10	120	190
	Anodized Aluminium/Banjo	Normally Closed	1/8"	1.2	-	10	50	192
			1/4"	1.2	-	10	50	192
	316L Stainless St./Sub-base Mounting	Normally Closed	SB	1.5	1.5	15	100	194
POM/Sub-base Mounting			SB	2	2	10	50	196
Stainless St./Sub-base Mounting	Normally Closed	SB	1.5 to 5	7.2	14	140	198	
		Universal	SB	1.5 to 3	3.3	9.5	140	200
Pilot Operated	Anodized Aluminium/Pipe Mounting	Normally Closed	1/4"	6.5 to 8	20	15	75	202
			1/2"	14	-	15	75	204
		Normally Open	1/4"	8	20	40	75	204
			1/2"	14	-	15	75	206
	Anodized Aluminium/Sub-base Mounting/Poppet	Normally Closed	SB	15	-	10	75	206

3/2

VALVES FOR DRY OR LUBRICATED AIR, NEUTRAL GASES AND LIQUIDS
DIRECT OPERATED

BRASS

PIPE MOUNTING

NORMALLY CLOSED

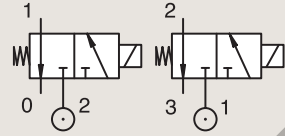

Port size	Orifice Ø		Flow factors			Operating Pressure Differential			Fluid Temp.		Seat Seal	Valve Ref.	Housing Ref.	Coil Ref.	IS	Power		Coil Group	Dwg. No.	
	1	(2)	1	(2)	1	(2)	Min	Max (MOPD)	Min	Max						AC W	DC W			
BSP	mm		Kv l/min		KV m³/h		bar	bar	bar	°C	°C									
1/8"	1.2	1.5	0.7	0.9	0.04	0.05	0	10	10	-10	75	FKM	131M15	8993	488980		2	2.5	1.1	3382
	1.2	1.5	0.7	0.9	0.04	0.05	0	10	10	-10	75	FKM	131M1550 ₁	8993	488980		2	2.5	1.1	3382
	1.5	1.5	0.9	0.9	0.05	0.05	0	7	7	-10	75	FKM	131M14	8993	488980		2	2.5	1.1	3382
	1.5	1.5	1.5	1.5	0.09	0.09	0	15	15	-10	120	FKM	E131K14	4270	481000		8	8	2.1	3510
	1.5	1.5	1.5	1.5	0.09	0.09	0	15	15	-10	100	FKM	E131K14	2995	481865		8	9	2.1	3510
	2	2.5	2.5	3.5	0.15	0.21	0	10	10	-10	120	FKM	131K16	4270	481000		8	8	2.1	3510
	2	2.5	2.5	3.5	0.15	0.21	0	10	10	-10	100	FKM	131K16	2995	481865		8	9	2.1	3510
	2	2.5	2.5	3.5	0.15	0.21	0	10	10	-10	120	FKM	131K1650 ₁	4270	481000		8	8	2.1	3510
	2	2.5	2.5	3.5	0.15	0.21	0	10	10	-10	100	FKM	131K1650 ₁	2995	481865		8	9	2.1	3510
	2.5	2.5	3.5	3.5	0.21	0.21	0	7	7	-10	120	FKM	E131K13	4270	481000		8	8	2.0	3510
2.5	2.5	3.5	3.5	0.21	0.21	0	7	7	-10	100	FKM	E131K13	2995	481865		8	9	2.0	3510	
2.5	2.5	3.5	3.5	0.21	0.21	0	7	7	-10	100	FKM	E131K13	4270	486265		14	14	2.0	3510	
1/8"-1/4"	2.5	2.5	3	3	0.18	0.18	0	-	2	-20	75	PUR	131K0397	2995	482740		-	1.6	6.0/8.0	8023
	2.5	2.5	3	3	0.18	0.18	0	2	2	-20	75	PUR	131K0397	-	495900		2.5	2	6.0/8.0	8023
	2.5	2.5	3	3	0.18	0.18	0	-	2	-20	75	PUR	131K0397	-	495910	*	-	0.3 to 3	6.0/8.0	8023
1/4"	1	1	0.6	0.6	0.03	0.03	0	-	10	-10	55	FKM	131K0490	2995	483580.01	*	-	0.5 to 3	7.0/8.0	7058
	1	1	0.6	0.6	0.03	0.03	0	-	10	-10	75	FKM	131K0490	-	48860.01	*	-	0.3 to 3	7.0/8.0	7058
	1	1	0.6	-	0.03	-	0	-	10	-10	75	FKM	131K0490	-	495910	*	-	0.3 to 3	7.0/8.0	7058

Notes:
1. With manual override

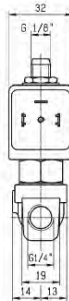
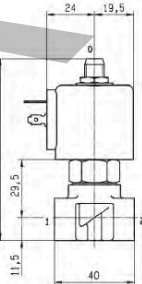
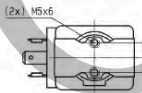

Drawing 7058



For this page	Port size	Orifice (mm)	Kv (l/min)	MOPD (bar)	Fluid Temp (°C)
From	1/8"	1.2	0.7	7	-10
To	1/8"	2.5	3.5	15	120

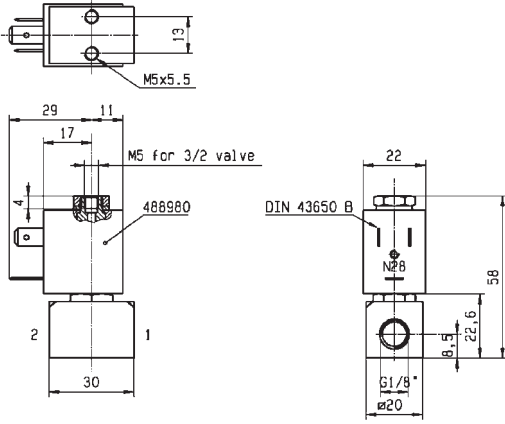

Drawing 3382

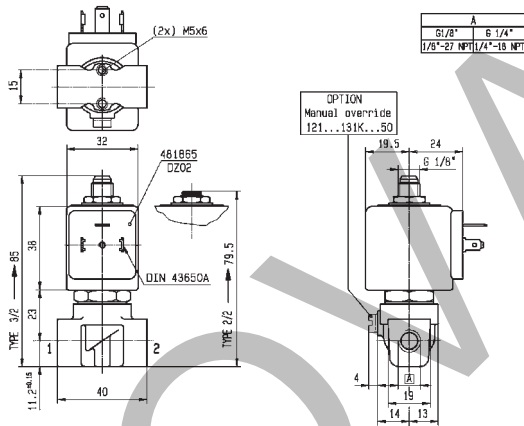

Drawing 3510

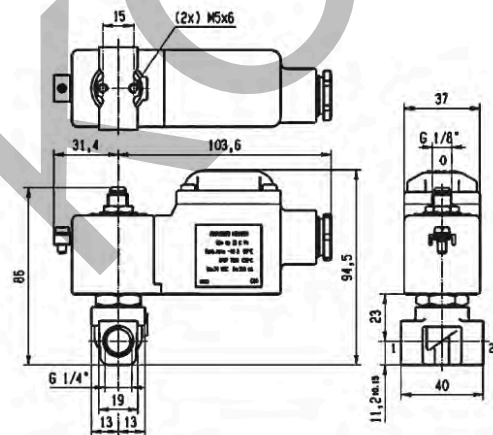

Drawing 8023

3/2

VALVES FOR DRY OR LUBRICATED AIR, NEUTRAL GASES AND LIQUIDS
DIRECT OPERATED

BRASS

PIPE MOUNTING

NORMALLY CLOSED

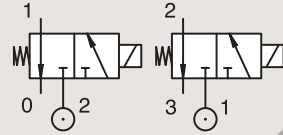

Port size	Orifice Ø		Flow factors			Operating Pressure Differential			Fluid Temp.		Seat Seal	Valve Ref.	Housing Ref.	Coil Ref.	IS	Power		Coil Group	Dwg. No.	
	1	(2)	1	(2)	1	(2)	Min	Max (MOPD)	Min	Max						AC W	DC W			
BSP	mm		Kv l/min		KV m³/h		bar	bar	°C	°C										
1/4"	1.2	1.5	0.8	1.5	0.05	0.09	0	30	-	-30	130	Ruby	E131K64	4270	481000	8	-	2.0	3510	
	1.2	1.5	0.8	1.5	0.05	0.09	0	30	30	-30	140	Ruby	E131K64	4270	486265	14	14	2.0	3510	
	1.2	1.5	0.8	1.5	0.05	0.09	0	30	-	-30	130	Ruby	E131K6450 ₁	4270	481000	8	-	2.0	3510	
	1.2	1.5	0.8	1.5	0.05	0.09	0	30	30	-30	140	Ruby	E131K6450 ₁	4270	486265	14	14	2.0	3510	
	1.5	1.5	1.5	1.5	0.09	0.09	0	-	7	-20	75	PUR	131K0497	2995	482740	-	1.6	6.0/8.0	8023	
	1.5	1.5	1.5	1.5	0.09	0.09	0	7	7	-20	75	PUR	131K0497	-	495900	2.5	2	6.0/8.0	8023	
	1.5	1.5	1.5	1.5	0.09	0.09	0	-	7	-20	75	PUR	131K0497	-	495910	*	-	0.3-1.2	6.0/8.0	8023
	1.5	1.5	1.5	1.5	0.09	0.09	0	-	7	-20	65	PUR	131K0497	2995	496125	-	1.6	6.0/8.0	8023	
	1.5	1.5	1.5	1.5	0.09	0.09	0	16	16	-10	120	FKM	E131K04	4270	481000	8	8	2.0	3510	
	1.5	1.5	1.5	1.5	0.09	0.09	0	16	16	-10	100	FKM	E131K04	2995	481865	8	9	2.0	3510	
	1.5	1.5	1.5	1.5	0.09	0.09	0	16	16	-10	120	FKM	E131K04	4270	486265	14	14	2.0	3510	
	1.5	1.5	1.5	1.5	0.09	0.09	0	15	15	-10	120	FKM	E131K0450 ₁	4270	481000	8	8	2.1	3510	
	1.5	1.5	1.5	1.5	0.09	0.09	0	15	15	-10	100	FKM	E131K0450 ₁	2995	481865	8	9	2.1	3510	
	2	3	2.5	4.5	0.15	0.27	0	10	10	-10	75	FKM	131T23	4270	481000	8	8	2.0	3223	
	2	3	2.5	4.5	0.15	0.27	0	10	10	-10	75	FKM	131T23	2995	481865	8	9	2.0	3223	
	2	3	2.5	4.5	0.15	0.27	0	10	10	-10	75	FKM	131T23	4270	486265	14	14	2.0	3223	
	2	3	2.5	4.5	0.15	0.27	0	10	10	-10	75	FKM	131T2301 ₁	4270	481000	8	8	2.0	3223	
	2	3	2.5	4.5	0.15	0.27	0	10	10	-10	75	FKM	131T2301 ₁	2995	481865	8	9	2.0	3223	
2	3	2.5	4.5	0.15	0.27	0	10	10	-10	75	FKM	131T2301 ₁	4270	486265	14	14	2.0	3223		

Notes:
1. With manual override



For this page	Port size	Orifice (mm)	Kv (l/min)	MOPD (bar)	Fluid Temp (°C)
From	1/4"	1	0.6	7	-30
To	1/4"	2	2.5	30	140

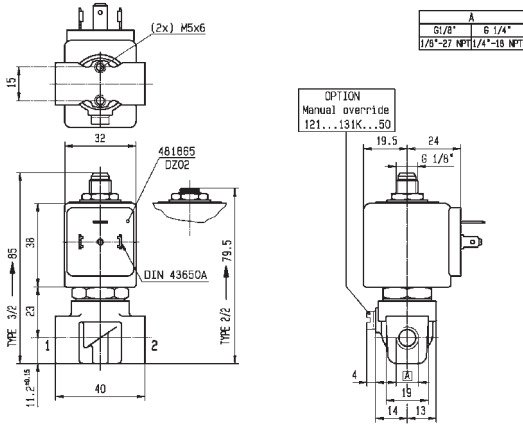

Drawing 3510

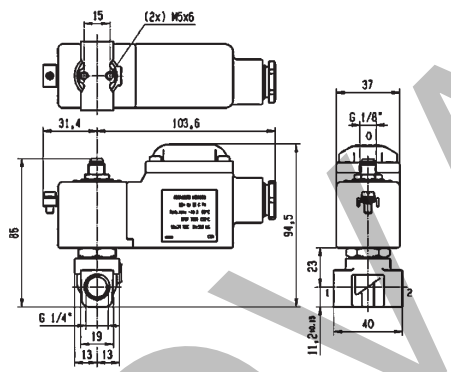

Drawing 8023

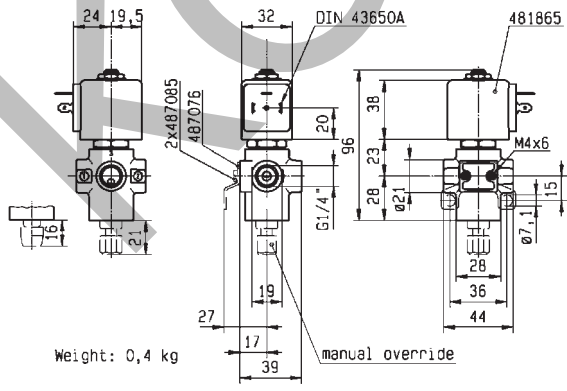

Drawing 3223



For this page	Port size	Orifice (mm)	Kv (l/min)	MOPD (bar)	Fluid Temp (°C)
From	1/4"	2	2.5	2	-40
To	1/4"	2.5	3.5	10	120

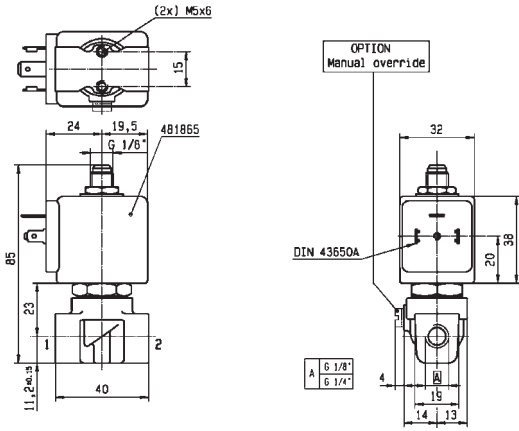

Drawing 8119

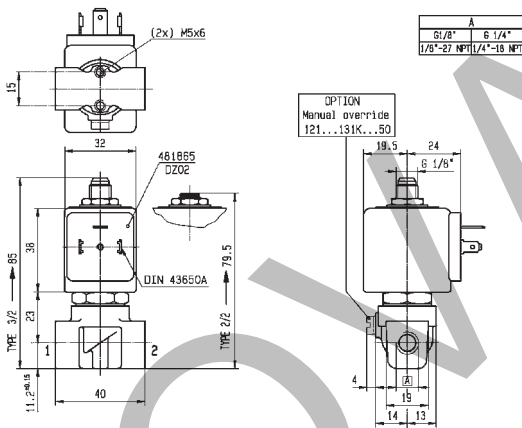

Drawing 3510

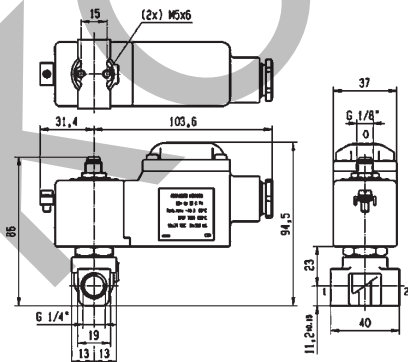

Drawing 8023

3/2

VALVES FOR DRY OR LUBRICATED AIR, NEUTRAL GASES AND LIQUIDS
DIRECT OPERATED

BRASS

PIPE MOUNTING

NORMALLY CLOSED

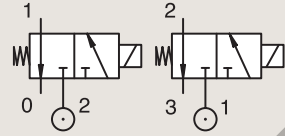

Port size	Orifice Ø		Flow factors			Operating Pressure Differential			Fluid Temp.		Seat Seal	Valve Ref.	Housing Ref.	Coil Ref.	IS	Power		Coil Group	Dwg. No.	
	1	(2)	1	(2)	1	(2)	Min	Max (MOPD)	Min	Max						AC W	DC W			
BSP	mm		Kv l/min		KV m³/h	bar	AC bar	DC bar	°C	°C										
1/4"	2.5	6	2.7	15	0.16	0.9	0.1	7	7	-10	75	FKM	E131E03	4270	481000		8	8	2.0	3525
	2.5	6	2.7	15	0.16	0.9	0.1	7	7	-10	75	FKM	E131E03	2995	481865		8	9	2.0	3525
	2.5	6	2.7	15	0.16	0.9	0.1	7	7	-10	75	FKM	E131E03	4270	486265		14	14	2.0	3525
	2.5	2.5	3.5	3.5	0.21	0.21	0	7	7	-10	100	FKM	E131K03	4270	481000		8	8	2.0	3510
	2.5	2.5	3.5	3.5	0.21	0.21	0	7	7	-10	100	FKM	E131K03	2995	481865		8	9	2.0	3510
	2.5	2.5	3.5	3.5	0.21	0.21	0	7	7	-40	75	PUR	E131K0308	4270	481000		8	8	2.1	3510
	2.5	2.5	3.5	3.5	0.21	0.21	0	7	7	-40	75	PUR	E131K0308	2995	481865		8	9	2.1	3510
	2.5	2.5	3.5	3.5	0.21	0.21	0	7	7	-10	120	FKM	E131K0350 ₁	4270	481000		8	8	2.1	3510
	2.5	2.5	3.5	3.5	0.21	0.21	0	7	7	-10	100	FKM	E131K0350 ₁	2995	481865		8	9	2.1	3510
	2.5	2.5	3.5	3.5	0.21	0.21	0	7	7	-30	130	Ruby	E131K63	4270	481000		8	8	2.0	3510
	2.5	2.5	3.5	3.5	0.21	0.21	0	7	7	-30	100	Ruby	E131K63	2995	481865		8	9	2.0	3510
	2.5	2.5	3.5	3.5	0.21	0.21	0	7	7	-30	130	Ruby	E131K6350 ₁	4270	481000		8	8	2.1	3510
	2.5	2.5	3.5	3.5	0.21	0.21	0	7	7	-30	100	Ruby	E131K6350 ₁	2995	481865		8	9	2.1	3510
	3	4	4.5	6	0.27	0.36	0	10	-	-10	75	FKM	131T22	4270	481044		14	-	2.2	3223
	3	4	4.5	6	0.27	0.36	0	10	-	-10	75	FKM	131T22	2995	492425		14	-	2.2	3223
4.5	6	7	9	0.42	0.54	0	2	2	-10	75	FKM	131T21	4270	481000		8	8	2.0	3223	
4.5	6	7	9	0.42	0.54	0	2	2	-10	75	FKM	131T21	2995	481865		8	9	2.0	3223	
4.5	6	7	9	0.42	0.54	0	2	2	-10	75	FKM	131T21	4270	486265		14	14	2.0	3223	

Notes:
1. With manual override

3 WAY VALVES



For this page	Port size	Orifice (mm)	Kv (l/min)	MOPD (bar)	Fluid Temp (°C)
From	1/4"	2.5	2.7	2	-40
To	1/4"	4.5	7	10	130

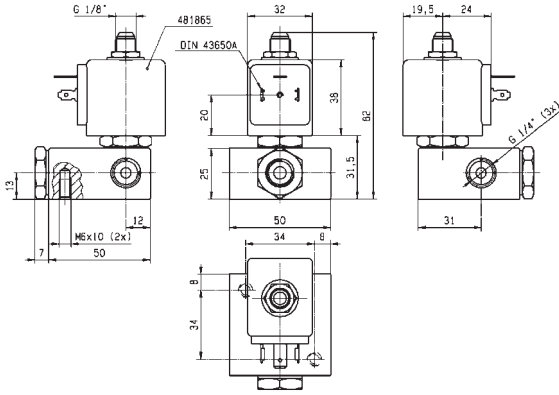

Drawing 3525

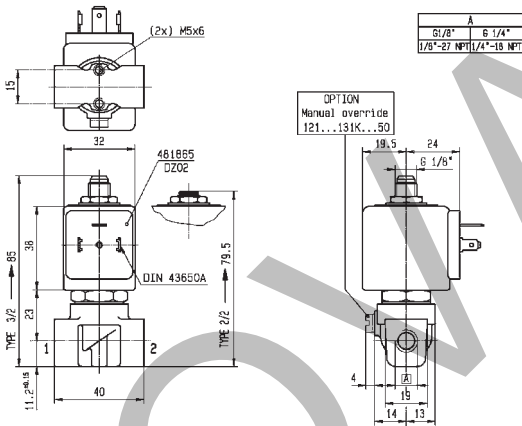

Drawing 3510

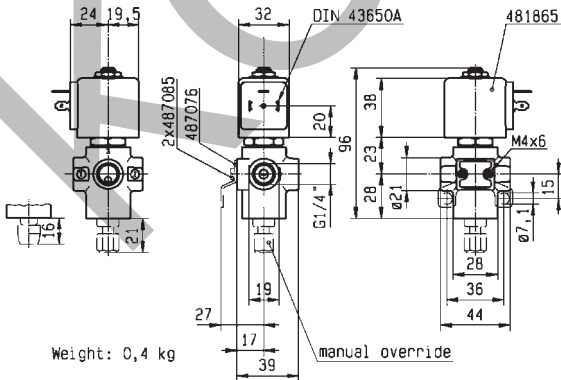

Weight: 0,4 kg



Drawing 3223

3/2

VALVES FOR DRY OR LUBRICATED AIR, NEUTRAL GASES AND LIQUIDS
DIRECT OPERATED

BRASS

PIPE MOUNTING

NORMALLY OPEN

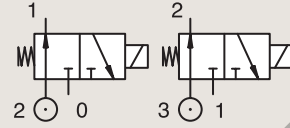

Port size	Orifice Ø		Flow factors				Operating Pressure Differential			Fluid Temp.		Seat Seal	Valve Ref.	Housing Ref.	Coil Ref.	Power		Coil Group	Dwg. No.
	1	(2)	1	(2)	1	(2)	Min	Max (MOPD)	Min	Max	AC W					DC W			
BSP	mm		Kv l/min		KV m³/h		bar	AC bar	DC bar	°C	°C								
1/4"	1.5	1.5	1.4	1.4	0.08	0.08	0	16	16	-10	120	FKM	132K04	4270	481000	8	8	2.1	3510
	1.5	1.5	1.4	1.4	0.08	0.08	0	16	16	-10	100	FKM	132K04	2995	481865	8	9	2.1	3510
	2	2	1.8	1.8	0.11	0.11	0	10	10	-10	120	FKM	132K06	4270	481000	8	8	2.1	3510
	2	2	1.8	1.8	0.11	0.11	0	10	10	-10	100	FKM	132K06	2995	481865	8	9	2.1	3510
	2	3	2.5	4.5	0.15	0.27	0	10	5	-10	75	FKM	132T23	4270	481000	8	8	2.0	3223
	2	3	2.5	4.5	0.15	0.27	0	10	5	-10	75	FKM	132T23	2995	481865	8	9	2.0	3223
	2	3	2.5	4.5	0.15	0.27	0	-	10	-10	75	FKM	132T23	4270	486265	-	14	2.0	3223
	2	3	2.5	4.5	0.15	0.27	0	10	5	-10	75	FKM	132T2301 ₁	4270	481000	8	8	2.0	3223
	2	3	2.5	4.5	0.15	0.27	0	10	5	-10	75	FKM	132T2301 ₁	2995	481865	8	9	2.0	3223
	2	3	2.5	4.5	0.15	0.27	0	-	10	-10	75	FKM	132T2301 ₁	4270	486265	-	14	2.0	3223
	2.5	2.5	2.2	2.2	0.13	0.13	0	7	7	-10	120	FKM	132K03	4270	481000	8	8	2.1	3510
	2.5	2.5	2.2	2.2	0.13	0.13	0	7	7	-10	100	FKM	132K03	2995	481865	8	9	2.1	3510
	3	4	4.5	6	0.27	0.36	0	10	-	-10	75	FKM	132T22	4270	481044	14	-	2.2	3223
	3	4	4.5	6	0.27	0.36	0	7	-	-10	75	FKM	132T22	2995	492425	14	-	2.2	3223

Notes:

1. With manual override



For this page	Port size	Orifice (mm)	Kv (l/min)	MOPD (bar)	Fluid Temp (°C)
From	1/4"	1.5	1.4	5	-10
To	1/4"	3	4.5	16	120

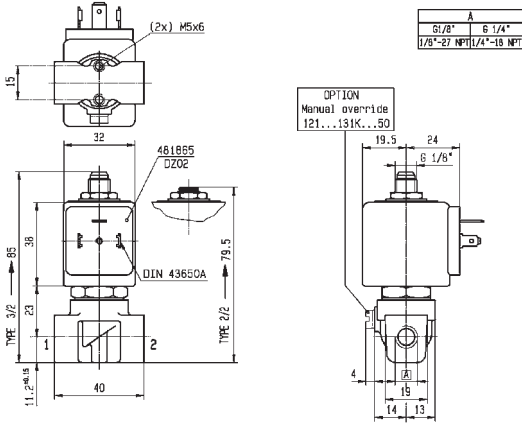

Drawing 3510

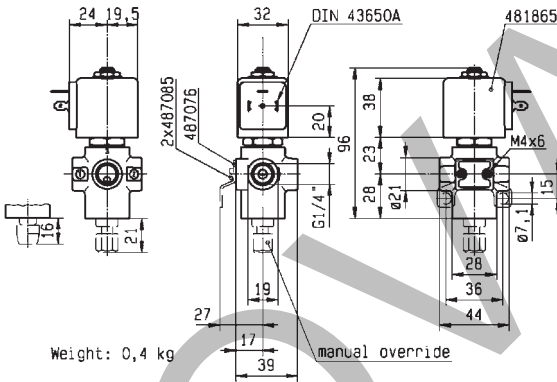

Drawing 3223

3/2

VALVES FOR DRY OR LUBRICATED AIR, NEUTRAL GASES AND LIQUIDS
DIRECT OPERATED

BRASS

PIPE MOUNTING

UNIVERSAL

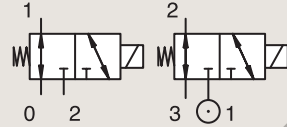

Port size	Orifice Ø		Flow factors		Operating Pressure Differential			Fluid Temp.		Seat Seal	Valve Ref.	Housing Ref.	Coil Ref.	IS	Power		Coil Group	Dwg. No.
	1	(2)	1	(2)	1	(2)	Min	Max (MOPD)	Min						Max	AC W		
BSP	mm		Kv l/min	KV m³/h	bar	AC bar	DC bar	°C	°C									
1/8"	1.5	1.5	1.5	0.09	0.09	0	10	10	-10	100	FKM	E133K14	2995	481865	8	9	2.1	3510
	1.5	1.5	1.5	0.09	0.09	0	10	10	-10	120	FKM	E133K14	4270	481000	8	8	2.1	3510
	2	2	2.5	0.15	0.15	0	7	7	-10	100	FKM	E133K16	2995	481865	8	9	2.1	3510
	2	2	2.5	-	0.15	0	7	7	-10	120	FKM	E133K16	4270	481000	8	8	2.1	3510
	2.5	2.5	3.5	0.21	0.21	0	4	4	-10	100	FKM	E133K13	2995	481865	8	9	2.1	3510
	2.5	2.5	3.5	0.21	0.21	0	4	4	-10	120	FKM	E133K13	4270	481000	8	8	2.1	3510
1/4"	0.8	0.8	0.3	0.02	0.02	0	30	30	-10	100	FKM	E133K05	2995	481865	8	9	2.1	3510
	0.8	0.8	0.3	0.02	0.02	0	30	30	-10	120	FKM	E133K05	4270	481000	8	8	2.1	3510
	0.8	0.8	0.3	0.02	0.02	0	30	30	-10	120	FKM	E133K05	4270	486265	14	14	2.0	3510
	1.5	1.5	1.5	0.09	0.09	0	-	3	-20	75	PUR	I33K0497	2995	482740	-	1.6	6.0/8.0	8023
	1.5	1.5	1.5	0.09	0.09	0	3	3	-20	75	PUR	I33K0497	-	495900	2.5	2	6.0/8.0	8023
	1.5	1.5	1.5	0.09	0.09	0	-	3	-20	75	PUR	I33K0497	-	495910	*	0.3-1.2	6.0/8.0	8023
	1.5	1.5	1.5	0.09	0.09	0	-	3	-20	65	PUR	I33K0497	2995	496125	-	1.6	6.0/8.0	8023
	1.5	1.5	1.5	0.09	0.09	0	10	10	-10	100	FKM	E133K04	2995	481865	8	9	2.0	3510
	1.5	1.5	1.5	0.09	0.09	0	10	10	-10	120	FKM	E133K04	4270	481000	8	8	2.0	3510
	1.5	1.5	1.5	0.09	0.09	0	10	10	-10	120	FKM	E133K04	4270	486265	14	14	2.0	3510
	1.5	1.5	1.5	0.09	0.09	0	10	10	-10	100	FKM	E133K0450	2995	481865	8	9	2.1	3510
	1.5	1.5	1.5	0.09	0.09	0	10	10	-10	120	FKM	E133K0450	4270	481000	8	8	2.1	3510
	2	2	2.5	0.15	0.15	0	7	7	-10	75	FKM	I33T23	2995	481865	8	9	2.1	3223
	2	2	2.5	0.15	0.15	0	7	7	-10	75	FKM	I33T23	4270	481000	8	8	2.1	3223
	2	2	2.5	0.15	0.15	0	7	7	-10	75	FKM	I33T2301	2995	481865	8	9	2.1	3223
	2	2	2.5	0.15	0.15	0	7	7	-10	75	FKM	I33T2301	4270	481000	8	8	2.1	3223
	2	2	2.5	0.15	0.15	0	7	7	-10	100	FKM	E133K06	2995	481865	8	9	2.0/3.0	3510
	2	2	2.5	0.15	0.15	0	7	7	-10	120	FKM	E133K06	4270	481000	8	8	2.0/3.0	3510
	2	2	2.5	0.15	0.15	0	7	7	-10	120	FKM	E133K06	4270	486265	14	14	2.0/3.0	3510
	2	2	2.5	0.15	0.15	0	7	7	-10	100	FKM	E133K0650	2995	481865	8	9	2.1	3510
	2	2	2.5	0.15	0.15	0	7	7	-10	120	FKM	E133K0650	4270	481000	8	8	2.1	3510
	2.5	2.5	3.5	0.21	0.21	0	4	4	-10	100	FKM	E133K03	2995	481865	8	9	2.0	3510
	2.5	2.5	3.5	0.21	0.21	0	4	4	-10	120	FKM	E133K03	4270	481000	8	8	2.0	3510
	2.5	2.5	3.5	0.21	0.21	0	4	4	-10	120	FKM	E133K03	4270	486265	14	14	2.0	3510
	2.5	2.5	3.5	0.21	0.21	0	4	4	-10	100	FKM	E133K0350	2995	481865	8	9	2.1	3510
	2.5	2.5	3.5	0.21	0.21	0	4	4	-10	120	FKM	E133K0350	4270	481000	8	8	2.1	3510
	3	3	4.5	0.27	0.27	0	2	2	-10	75	FKM	I33T21	2995	481865	8	9	2.1	3223
3	3	4.5	0.27	0.27	0	2	2	-10	75	FKM	I33T21	4270	481000	8	8	2.1	3223	

Notes:
1. With manual override



For this page	Port size	Orifice (mm)	Kv (l/min)	MOPD (bar)	Fluid Temp (°C)
From	1/8"	0.8	0.3	2	-20
To	1/4"	3	4.5	30	120

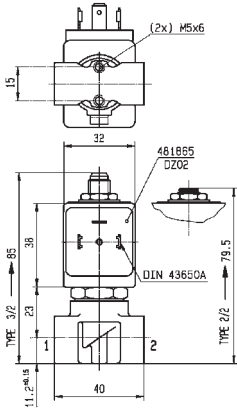

A	
1/8"	6 1/4"
1/8"-27 NPT	1/4"-18 NPT

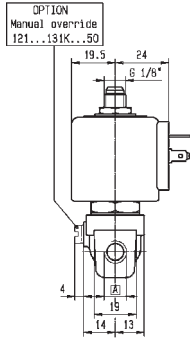

Drawing 3510

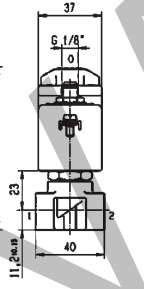
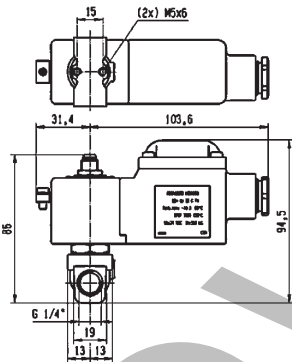

Drawing 8023

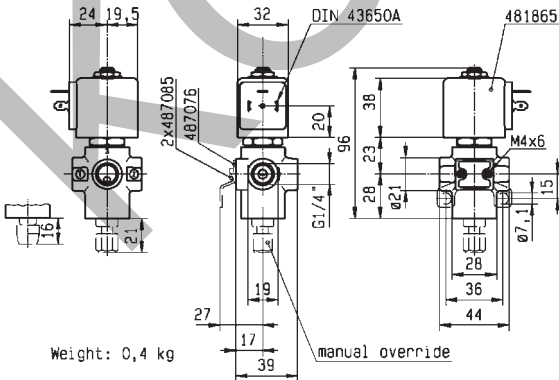

Weight: 0,4 kg



Drawing 3223

3/2

VALVES FOR DRY OR LUBRICATED AIR, NEUTRAL GASES AND LIQUIDS
DIRECT OPERATED

BRASS

PIPE MOUNTING

UNIVERSAL

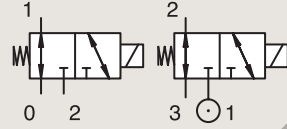

Port size	Orifice Ø		Flow factors				Operating Pressure Differential			Fluid Temp.		Seat Seal	Valve Ref.	Housing Ref.	Coil Ref.	IS		Power		Coil Group	Dwg. No.
	1	(2)	1	(2)	1	(2)	Min	Max (MOPD)	Min	Max	AC W					DC W					
BSP	mm		Kv	l/min	KV	m³/h	bar	AC bar	DC bar	°C	°C										
1/4"	3	3	4.5	4.5	0.27	0.27	0	2	2	-10	75	FKM	133T2101	2995	481865	8	9	2.1	3223		
	3	3	4.5	4.5	0.27	0.27	0	2	2	-10	75	FKM	133T2101	4270	481000	8	8	2.1	3223		

Notes:

1. With manual override

BRASS

PIPE MOUNTING

CONTROL BY ELECTRIC IMPULSE

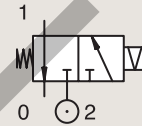

Port size	Orifice Ø		Flow factors				Operating Pressure Differential			Fluid Temp.		Seat Seal	Valve Ref.	Housing Ref.	Coil Ref.	Power		Coil Group	Dwg. No.
	1	(2)	1	(2)	1	(2)	Min	Max (MOPD)	Min	Max	AC W					DC W			
BSP	mm		Kv	l/min	KV	m³/h	bar	AC bar	DC bar	°C	°C								
1/4"	1.5	1.5	1.5	1.5	0.09	0.09	0	-	16	-10	100	FKM	135K04	4269	485400	-	13	4.0	8104



For this page	Port size	Orifice (mm)	Kv (l/min)	MOPD (bar)	Fluid Temp (°C)
From	1/4"	1.5	1.5	2	-10
To	1/4"	3	4.5	16	100

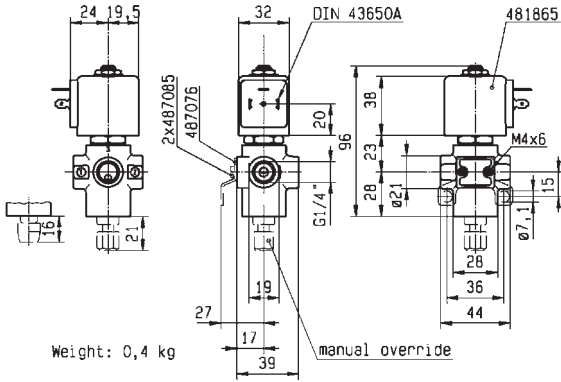

Weight: 0,4 kg

manual override



Drawing 3223

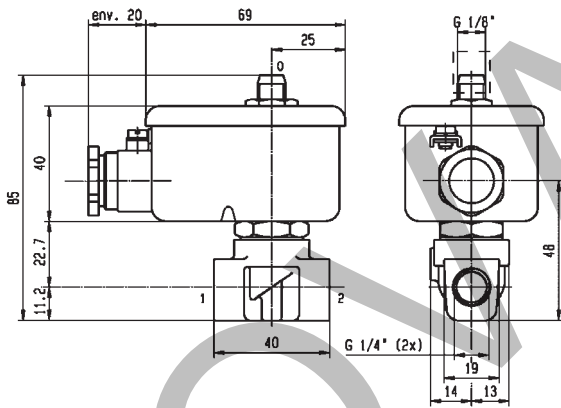

Drawing 8104

3/2

VALVES FOR DRY OR LUBRICATED AIR, NEUTRAL GASES AND LIQUIDS
DIRECT OPERATED

BRASS

SUB-BASE MOUNTING

NORMALLY CLOSED

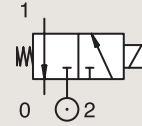

Port size	Orifice Ø		Flow factors			Operating Pressure Differential			Fluid Temp.		Seat Seal	Valve Ref.	Housing Ref.	Coil Ref.	IS	Power		Coil Group	Dwg. No.	
	1	(2)	1	(2)	1	(2)	Min	Max (MOPD)	Min	Max						AC W	DC W			
	mm		Kv l/min		KV m ³ /h		bar	AC bar	DC bar	°C										°C
SB	1.2	1.5	0.7	0.9	0.04	0.05	0	10	10	-10	75	FKM	131M75	8993	488980		2	2.5	1.1	3383
	1.2	1.5	0.7	0.9	0.04	0.05	0	10	10	-10	75	FKM	131M7550	8993	488980		2	2.5	1.1	3383
	1.5	1.5	0.9	0.9	0.05	0.05	0	7	7	-10	75	FKM	131M74	8993	488980		2	2.5	1.1	3383
	1.5	1.5	0.9	0.9	0.05	0.05	0	7	7	-10	75	FKM	131M7450	8993	488980		2	2.5	1.1	3383
SB	1	1	0.6	0.6	0.04	0.036	0	-	10	-10	55	FKM	131F4490	2995	48358001	*	-	0.5-3	7.0	7057
	1	1	0.6	0.6	0.04	0.036	0	-	10	-10	75	FKM	131F4490	-	495910	*	-	0.3-1.2	7.0	7057
	1.5	2	1.5	2.2	0.09	0.13	0	-	16	-10	100	FKM	131F4410	2995	481865		-	9	2.1	3509
	1.5	1.5	1.5	1.5	0.09	0.09	0	-	7	-20	75	PUR	131F4497	2995	482740		-	1.6	6.0/8.0	8022
	1.5	1.5	1.5	1.5	0.09	0.09	0	7	7	-20	75	PUR	131F4497	-	495900		2.5	2	6.0/8.0	8022
	1.5	1.5	1.5	1.5	0.09	0.09	0	-	7	-20	75	PUR	131F4497	-	495910	*	-	0.3-1.2	6.0/8.0	8022
	1.5	1.5	1.5	1.5	0.09	0.09	0	-	7	-20	65	PUR	131F4497	2995	496125		-	1.6	6.0/8.0	8022

Notes:

1. With manual override

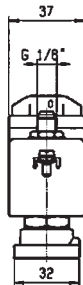
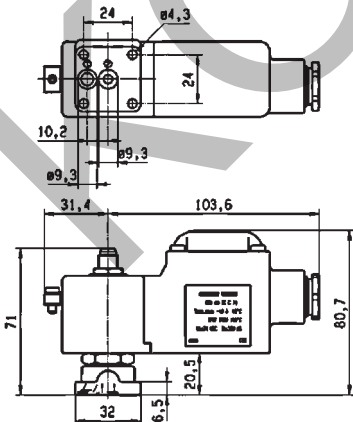

Drawing 8022

3 WAY VALVES



For this page	Port size	Orifice (mm)	Kv (l/min)	MOPD (bar)	Fluid Temp (°C)
From	SB	1	0.6	7	-20
To	SB	1.5	1.5	16	100

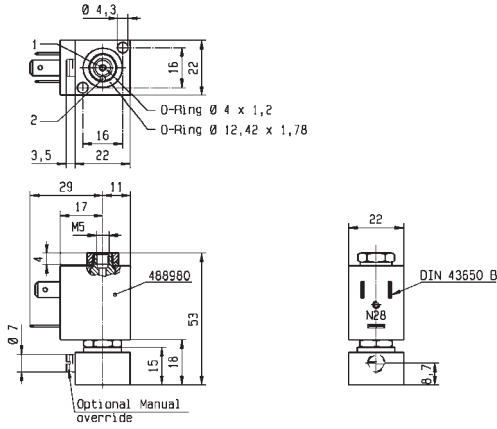

Drawing 3383

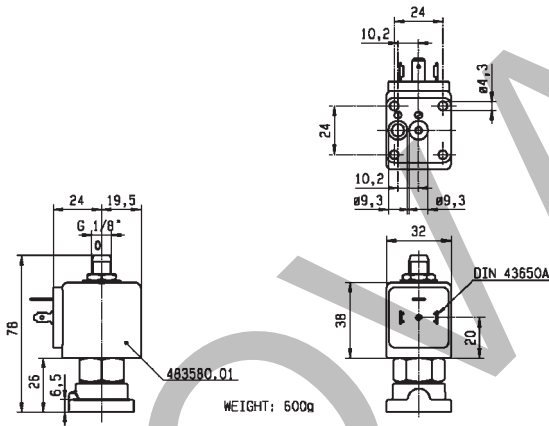

Drawing 7057

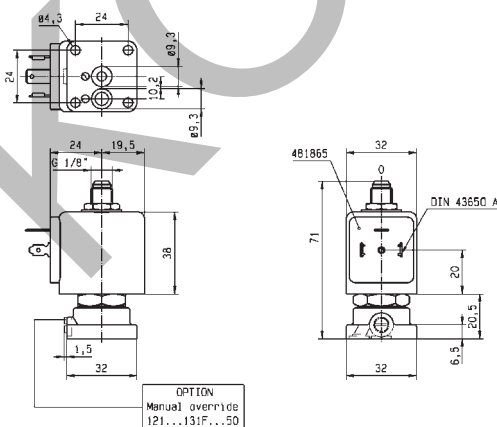

Drawing 3509

3/2

VALVES FOR DRY OR LUBRICATED AIR, NEUTRAL GASES AND LIQUIDS
DIRECT OPERATED

BRASS

SUB-BASE MOUNTING

NORMALLY CLOSED

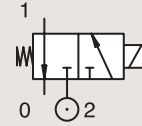

Port size	Orifice Ø		Flow factors				Operating Pressure Differential			Fluid Temp.		Seat Seal	Valve Ref.	Housing Ref.	Coil Ref.	IS	Power		Coil Group	Dwg. No.
	1	(2)	1	(2)	1	(2)	Min	Max (MOPD)	Min	Max	AC W						DC W			
	mm		Kv l/min		KV m³/h		bar	AC bar	DC bar	°C								°C		
SB	1.5	1.5	1.5	1.5	0.09	0.09	0	15	15	-10	100	FKM	E131F44	2995	481865		8	9	2.1	3509
	1.5	1.5	1.5	1.5	0.09	0.09	0	15	15	-10	120	FKM	E131F44	4270	481000		8	8	2.1	3509
	1.5	1.5	1.5	1.5	0.09	0.09	0	15	15	-10	100	FKM	E131F4450 ₁	2995	481865		8	9	2.1	3509
	1.5	1.5	1.5	1.5	0.09	0.09	0	15	15	-10	100	FKM	E131F4450 ₁	4270	481000		8	8	2.1	3509
	2	2.5	2.5	3.5	0.15	0.21	0	10	10	-10	100	FKM	131F46	2995	481865		8	9	2.1	3509
	2	2.5	2.5	3.5	0.15	0.21	0	10	10	-10	120	FKM	131F46	4270	481000		8	8	2.1	3509
	2	2.5	2.5	3.5	0.15	0.21	0	10	10	-10	100	FKM	131F4650 ₁	2995	481865		8	9	2.1	3509
	2	2.5	2.5	3.5	0.15	0.21	0	10	10	-10	120	FKM	131F4650 ₁	4270	481000		8	8	2.1	3509
	2.5	2.5	3.5	3.5	0.21	0.21	0	7	7	-10	100	FKM	E131F43	2995	481865		8	9	2.1	3509
	2.5	2.5	3.5	3.5	0.21	0.21	0	7	7	-10	120	FKM	E131F43	4270	481000		8	8	2.1	3509
	2.5	2.5	3.5	3.5	0.21	0.21	0	7	7	-10	100	FKM	E131F4350 ₁	2995	481865		8	9	2.0	3509
	2.5	2.5	3.5	3.5	0.21	0.21	0	7	7	-10	120	FKM	E131F4350 ₁	4270	481000		8	8	2.0	3509
	2.5	2.5	3.5	3.5	0.21	0.21	0	7	7	-10	100	FKM	E131F4350 ₁	4270	486265		14	14	2.0	3509

Notes:

1. With manual override

BRASS

SUB-BASE MOUNTING

NORMALLY OPEN

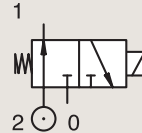

Port size	Orifice Ø		Flow factors				Operating Pressure Differential			Fluid Temp.		Seat Seal	Valve Ref.	Housing Ref.	Coil Ref.	Power	Coil Group	Dwg. No.		
	1	(2)	1	(2)	1	(2)	Min	Max (MOPD)	Min	Max	AC W								DC W	
	mm		Kv l/min		KV m³/h		bar	AC bar	DC bar	°C										°C
SB	1.5	1.5	1.4	1.4	0.08	0.08	0	15	15	-10	75	FKM	132F44	4270	481000		8	8	2.1	3509
	1.5	1.5	1.4	1.4	0.08	0.08	0	15	15	-10	75	FKM	132F44	2995	481865		8	9	2.1	3509
	2	2	1.8	1.8	0.11	0.11	0	10	10	-10	120	FKM	132F46	4270	481000		8	8	2.1	3509
	2	2	1.8	1.8	0.11	0.11	0	10	10	-10	100	FKM	132F46	2995	481865		8	9	2.1	3509
	2.5	2.5	2.2	2.2	0.13	0.13	0	7	7	-10	75	FKM	132F43	4270	481000		8	8	2.0	3509
	2.5	2.5	2.2	2.2	0.13	0.13	0	7	7	-10	75	FKM	132F43	2995	481865		8	9	2.0	3509
	2.5	2.5	2.2	2.2	0.13	0.13	0	7	7	-10	75	FKM	132F43	4270	486265		14	14	2.0	3509

3/2

VALVES FOR DRY OR LUBRICATED AIR, NEUTRAL GASES AND LIQUIDS
DIRECT OPERATED

BRASS

SUB-BASE MOUNTING

UNIVERSAL

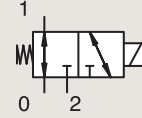

Port size	Orifice Ø		Flow factors			Operating Pressure Differential			Fluid Temp.		Seat Seal	Valve Ref.	Housing Ref.	Coil Ref.	Power		Coil Group	Dwg. No.	
	1	(2)	1	(2)	1	(2)	Min	Max (MOPD)	Min	Max					AC W	DC W			
	mm		Kv l/min		KV m³/h		bar	AC bar	DC bar	°C									°C
SB	1.5	1.5	1.5	1.5	0.09	0.09	0	10	10	-10	100	FKM	E133F4450	4270	481000	8	8	2.1	3509
	1.5	1.5	1.5	1.5	0.09	0.09	0	10	10	-10	120	FKM	E133F4450	2995	481865	8	9	2.1	3509
	1.5	1.5	1.5	1.5	0.09	0.09	0	10	10	-10	120	FKM	E133F44	4270	481000	8	8	2.1	3509
	1.5	1.5	1.5	1.5	0.09	0.09	0	10	10	-10	100	FKM	E133F44	2995	481865	8	9	2.1	3509
	2	2	2.5	2.5	0.15	0.15	0	7	7	-10	120	FKM	133F46	4270	481000	8	8	2.1	3509
	2	2	2.5	2.5	0.15	0.15	0	7	7	-10	100	FKM	133F46	2995	481865	8	9	2.1	3509
	2.5	2.5	3.5	3.5	0.21	0.21	0	4	4	-10	120	FKM	E133F43	4270	481000	8	8	2.1	3509
	2.5	2.5	3.5	3.5	0.21	0.21	0	4	4	-10	100	FKM	E133F43	2995	481865	8	9	2.1	3509

Notes:
1. With manual override

KONVA



For this page	Port size	Orifice (mm)	Kv (l/min)	MOPD (bar)	Fluid Temp (°C)
From	SB	1.5	1.5	4	-10
To	SB	2.5	3.5	10	120

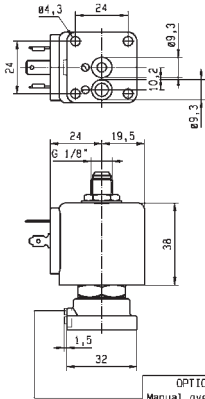

OPTION
Manual override
121...131F...50

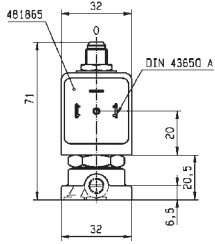

Drawing 3509

3/2

VALVES FOR DRY OR LUBRICATED AIR, NEUTRAL GASES AND LIQUIDS
DIRECT OPERATED

ANODIZED ALUMINIUM

BANJO

NORMALLY CLOSED

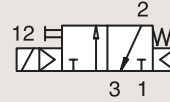

Port size	Orifice Ø 1	Flow factor Qn l/min	Operating Pressure Differential		Fluid Temp.		Seat Seal	Valve Ref.	Housing Ref.	Coil Ref.	Power		Coil Group	Dwg. No.
			Min bar	Max (MOPD) AC bar DC bar	Min °C	Max °C					AC W	DC W		
BSP	1.2	50	0	10 10	-10 50	NBR	131B14 ₁₂	-	496131	3 3	1.2	8227		
1/8"	1.2	50	0	10 10	-10 50	NBR	131B14 ₁₂	-	496482	3 3	1.2	8227		
	1.2	50	0	10 10	-10 50	NBR	131B14 ₁₂	-	496637	3 3	1.2	8227		

Notes:

- 1.Valve only compatible with air and neutral gases
- 2.With manual override

ANODIZED ALUMINIUM

BANJO

NORMALLY CLOSED

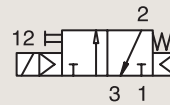

Port size	Orifice Ø 1	Flow factor Qn l/min	Operating Pressure Differential		Fluid Temp.		Seat Seal	Valve Ref.	Housing Ref.	Coil Ref.	Power		Coil Group	Dwg. No.
			Min bar	Max (MOPD) AC bar DC bar	Min °C	Max °C					AC W	DC W		
BSP	1.2	50	0	10 10	-10 50	NBR	131B04 ₁₂	-	496131	3 3	1.2	8226		
1/4"	1.2	50	0	10 10	-10 50	NBR	131B04 ₁₂	-	496482	3 3	1.2	8226		
	1.2	50	0	10 10	-10 50	NBR	131B04 ₁₂	-	496637	3 3	1.2	8226		

Notes:

- 1.Valve only compatible with air and neutral gases
- 2.With manual override



For this page	Port size	Orifice (mm)	Qn (l/min)	MOPD (bar)	Fluid Temp (°C)
From	1/8"	1.2	50	10	-10
To	1/4"	1.2	50	10	50

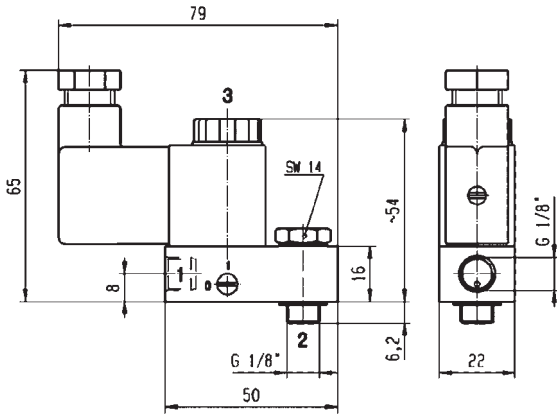

Drawing 8227

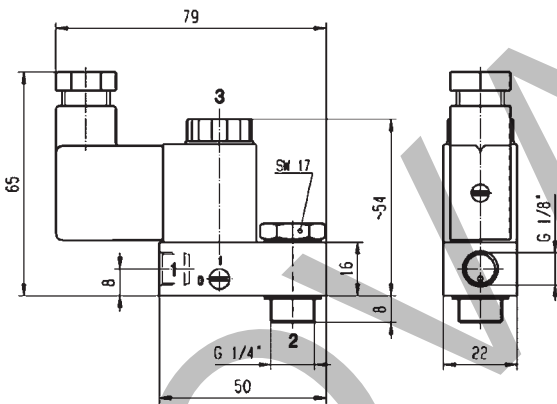

Drawing 8226

3/2

VALVES FOR DRY OR LUBRICATED AIR, NEUTRAL GASES AND LIQUIDS
DIRECT OPERATED

316L STAINLESS ST.
SUB-BASE MOUNTING

NORMALLY CLOSED

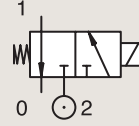

Port size	Orifice Ø		Flow factors				Operating Pressure Differential			Fluid Temp.		Seat Seal	Valve Ref.	Housing Ref.	Coil Ref.	Power		Coil Group	Dwg. No.
	1	(2)	1	(2)	1	(2)	Min	Max (MOPD)	Min	Max	AC W					DC W			
BSP	mm		Kv l/min		KV m³/h		bar	AC bar	DC bar	°C	°C				8	9			
SB	1.5	1.5	1.5	2.2	0.09	0.13	0	15	15	-10	100	FKM	131F5406	2995	481865	8	9	2.1	3509

KONVAZ



For this page	Port size	Orifice (mm)	Kv (l/min)	MOPD (bar)	Fluid Temp (°C)
From	SB	1.5	1.5	15	-10
To	SB	1.5	1.5	15	100

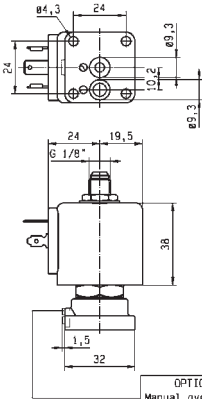

OPTION
Manual override
121...131F...50

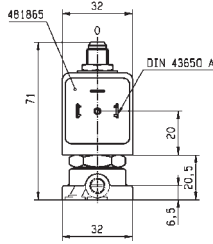

Drawing 3509

3/2

VALVES FOR DRY OR LUBRICATED AIR, NEUTRAL GASES AND LIQUIDS
DIRECT OPERATED

POM

SUB-BASE MOUNTING

NORMALLY CLOSED

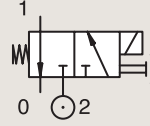

Port size	Orifice Ø		Flow factors				Operating Pressure Differential			Fluid Temp.		Seat Seal	Valve Ref.	Housing Ref.	Coil Ref.	Power		Coil Group	Dwg. No.
	1	(2)	1	(2)	1	(2)	Min	Max (MOPD)		Min	Max					AC W	DC W		
	mm		Kv l/min		KV m³/h		bar	AC bar	DC bar	°C	°C								
SB	2	2	2	2	0.12	0.12	0	10	10	-10	50	FKM	E131F26 ₁₂	2995	481865	8	9	2.1/3.0	3601
	2	2	2	2	0.12	0.12	0	10	10	-10	50	FKM	E131F26 ₂	2995	482730	6	7	2.1/3.0	3601

Notes:

- 1.20% Switch-on - max. 2 min
- 2.With manual override

KONVARI



For this page	Port size	Orifice (mm)	Kv (l/min)	MOPD (bar)	Fluid Temp (°C)
From	SB	2	2	10	-10
To	SB	2	2	10	50

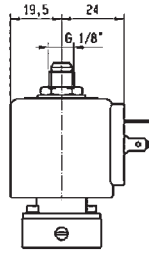
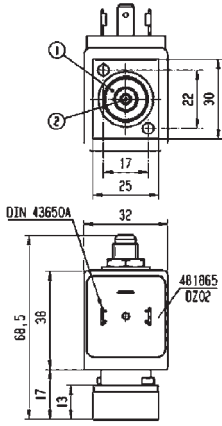

Drawing 3601

KOLVAR

3/2

VALVES FOR DRY OR LUBRICATED AIR, NEUTRAL GASES AND LIQUIDS
DIRECT OPERATED

STAINLESS ST.
SUB-BASE MOUNTING

NORMALLY CLOSED

Port size	Orifice Ø		Flow factors				Operating Pressure Differential			Fluid Temp.		Seat Seal	Valve Ref.	Coil Ref.	Power		Coil Group	Compatible Adapter Kit
	1	(2)	1	(2)	1	(2)	Min	Max (MOPD)		Min	Max				AC	DC		
	mm		Kv		KV		bar	AC	DC	°C	°C				W	W		
SB	1.5	2.5	1.4	2.9	0.08	0.17	0	14	14	-10	140	Ruby	3019F1GRG7	481865	9	8	2.0	XGSPG1-XGSPG2
	1.5	2.5	1.4	2.9	0.08	0.17	0	14	14	-10	140	FKM FDA	3019F1GVG7	481865	9	8	2.0	XGSPG1-XGSPG2
	2.0	2.5	2.1	2.9	0.13	0.17	0	10	10	-10	140	Ruby	3019F1JRG7	481865	9	8	2.0	XGSPG1-XGSPG2
	2.0	2.5	2.1	2.9	0.13	0.17	0	10	10	-10	140	FKM FDA	3019F1JVG7	481865	9	8	2.0	XGSPG1-XGSPG2
	2.5	2.5	2.9	2.9	0.17	0.17	0	6.5	6.5	-10	140	Ruby	3019F1LRG7	481865	9	8	2.0	XGSPG1-XGSPG2
	2.5	2.5	2.9	2.9	0.17	0.17	0	6.5	6.5	-10	140	FKM FDA	3019F1LVG7	481865	9	8	2.0	XGSPG1-XGSPG2
	3.0	2.5	3.3	2.9	0.20	0.17	0	4	4	-10	140	Ruby	3019F1NRG7	481865	9	8	2.0	XGSPG1-XGSPG2
	3.0	2.5	3.3	2.9	0.20	0.17	0	4	4	-10	140	FKM FDA	3019F1NVG7	481865	9	8	2.0	XGSPG1-XGSPG2
	4.0	2.5	6.5	2.9	0.39	0.17	0	3	3	-10	140	FKM FDA	3019F1QVG7	481865	9	8	2.0	XGSPG3
	4.0	2.5	6.5	2.9	0.39	0.17	0	3	3	-10	140	EPDM	3019F1QEG7	481865	9	8	2.0	XGSPG3
	5.0	2.5	7.2	0.43	0.43	0.17	0	2	2	-10	140	FKM FDA	3019F1SVG7	481865	9	8	2.0	XGSPG3
	5.0	2.5	7.2	0.43	0.43	0.17	0	2	2	-10	140	EPDM	3019F1SEG7	481865	9	8	2.0	XGSPG3

3 WAY VALVES



For this page	Port size	Orifice (mm)	Kv (l/min)	MOPD (bar)	Fluid Temp (°C)
From	SB	2	2	10	-10
To	SB	2	2	10	50

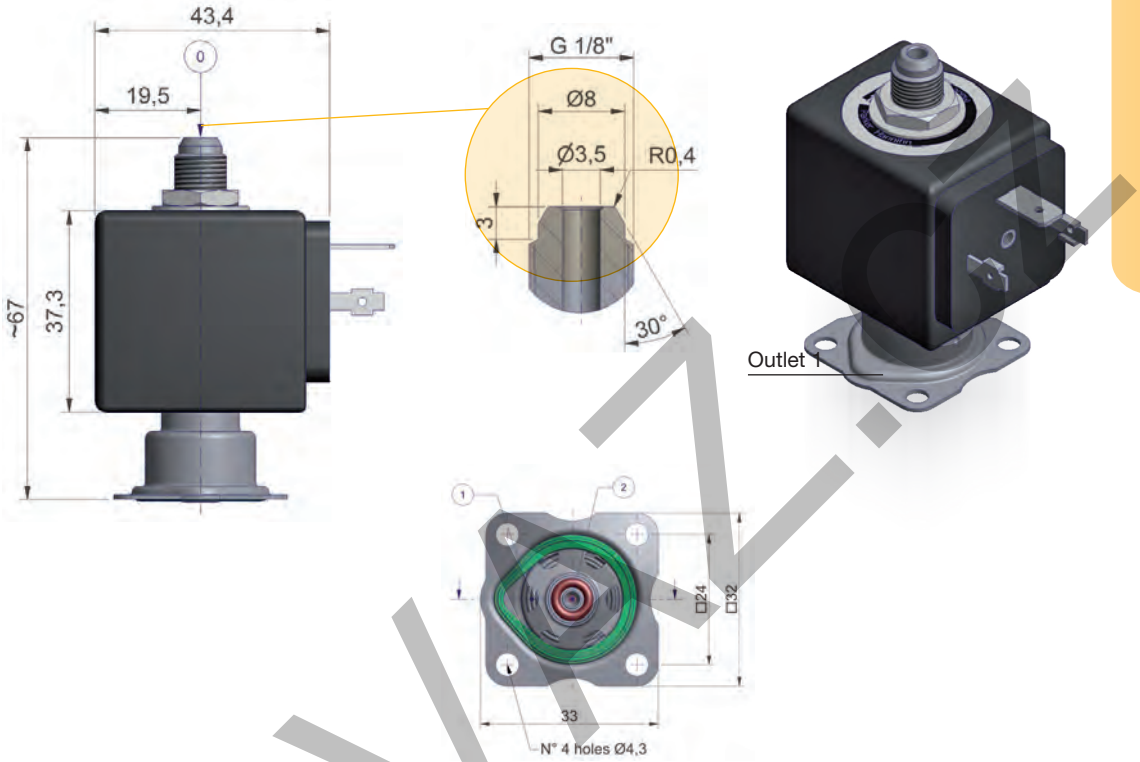

All dimensions are in mm

KO

3/2

VALVES FOR DRY OR LUBRICATED AIR, NEUTRAL GASES AND LIQUIDS
DIRECT OPERATED

STAINLESS ST.
SUB-BASE MOUNTING

UNIVERSAL

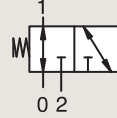

Port size	Orifice Ø		Flow factors				Operating Pressure Differential			Fluid Temp.		Seat Seal	Valve Ref.	Coil Ref.	Power		Coil Group	Compatible Adapter Kit
	1	(2)	1	(2)	1	(2)	Min	Max (MOPD)	Min	Max	AC W				DC W			
	mm		Kv l/min		KV m³/h	bar	AC bar	DC bar	°C	°C								
SB	1.5	1.5	1.4	1.3	0.08	0.8	0	9.5	9.5	-10	140	FKM FDA	3039F1GVG7	481865	9	8	2.0	XGSPG1 - XGSPG2
	1.5	1.5	1.4	1.3	0.08	0.08	0	9.5	9.5	-10	140	EPDM	3039F1GEG7	481865	9	8	2.0	XGSPG1 - XGSPG2
	2.0	2.0	2.1	2.0	0.13	0.12	0	3.5	3.5	-10	140	FKM FDA	3039F1JVG7	481865	9	8	2.0	XGSPG1 - XGSPG2
	2.0	2.0	2.1	2.0	0.13	0.12	0	3.5	3.5	-10	140	EPDM	3039F1JEG7	481865	9	8	2.0	XGSPG1 - XGSPG2
	2.5	2.5	2.8	2.8	0.17	0.17	0	2	2	-10	140	FKM FDA	3039F1LVG7	481865	9	8	2.0	XGSPG1 - XGSPG2
	2.5	2.5	2.8	2.8	0.17	0.168	0	2	2	-10	140	EPDM	3039F1LEG7	481865	9	8	2.0	XGSPG1 - XGSPG2
	3.0	2.5	3.3	2.8	0.2	0.17	0	2	2	-10	140	FKM FDA	3039F1NVG7	481865	9	8	2.0	XGSPG1 - XGSPG2
	3.0	2.5	3.3	2.8	0.2	0.168	0	2	2	-10	140	EPDM	3039F1NEG7	481865	9	8	2.0	XGSPG1 - XGSPG2

KONVA

3 WAY VALVES



For this page	Port size	Orifice (mm)	Kv (l/min)	MOPD (bar)	Fluid Temp (°C)
From	SB	2	2	10	-10
To	SB	2	2	10	50

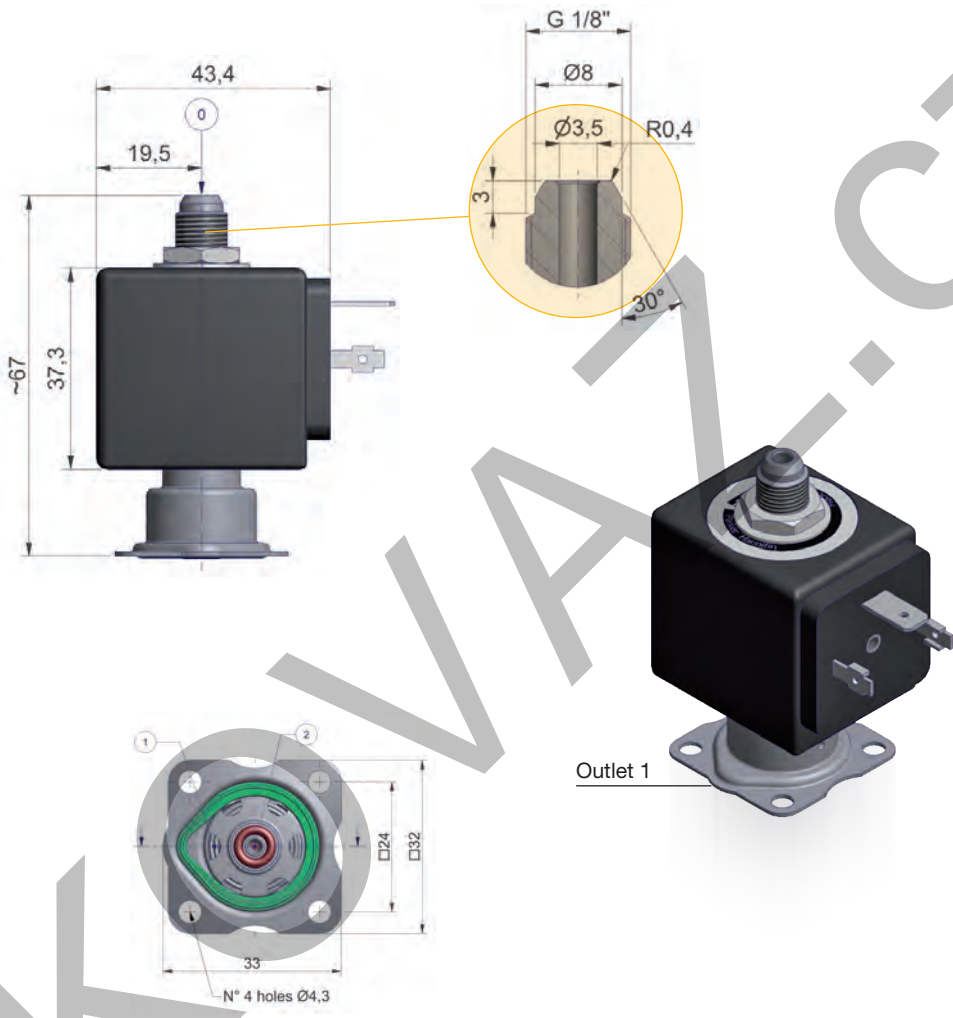

All dimensions are in mm

3/2

VALVES FOR DRY OR LUBRICATED AIR, NEUTRAL GASES AND LIQUIDS
PILOT OPERATED

ANODIZED ALUMINIUM

PIPE MOUNTING

NORMALLY CLOSED

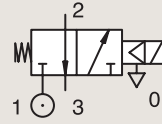

Port size	Orifice Ø		Flow factors			Operating Pressure Differential			Fluid Temp.		Seat Seal	Valve Ref.	Housing Ref.	Coil Ref.	IS	Power		Coil Group	Dwg. No.	
	1	(2)	1	(2)	1	(2)	Min	Max (MOPD)	Min	Max						AC W	DC W			
BSP	mm		Kv l/min		Q l/min	bar	bar	°C	°C											
1/4"	6.5	6.5	10	-	645	-	1	-	10	-10	55	NBR	331B7490 ₁	2995	48358001	*	-	0.5-3	7.0/8.0	8270
	6.5	6.5	10	-	645	-	1	-	10	-10	75	NBR	331B7490 ₁	-	495910	*	-	0.3-1.2	7.0/8.0	8270
	6.5	6.5	10	-	750	-	1	10	10	-10	75	NBR	E331B74 ₁₃	2995	481865		8	9	2.1	3240
	6.5	6.5	10	-	750	-	1	10	10	-10	75	NBR	E331B74 ₁₃	4270	485100		8	8	2.1	3240
	8	8	20	20	1100	1100	1	15	15	-10	75	NBR	E331B01 ₂	4270	481000		8	8	2.1	3234
	8	8	20	20	1100	1100	1	15	15	-10	75	NBR	E331B01 ₂	2995	481865		8	9	2.1	3234
	8	8	20	20	1100	1100	1	15	15	-10	65	NBR	E331B01 ₂	-	483371		8	8	2.1	3234

Notes:

- 1.Valve only compatible with air and neutral gases
- 2.Valve only compatible with hydraulic oil and air/neutral gases
- 3.With manual override

KONVA

3 WAY VALVES



For this page	Port size	Orifice (mm)	Kv (l/min)	MOPD (bar)	Fluid Temp (°C)
From	1/4"	6.5	10	10	-10
To	1/4"	8	20	15	75

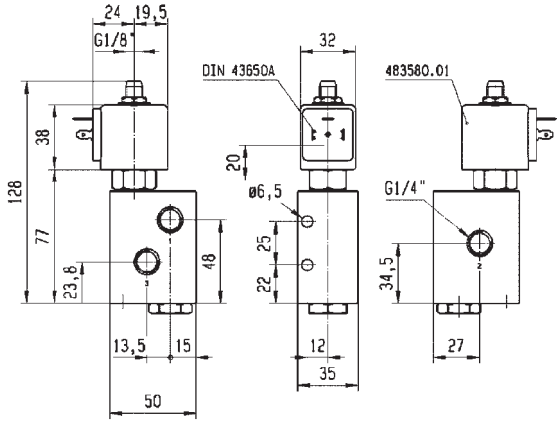

Drawing 8270

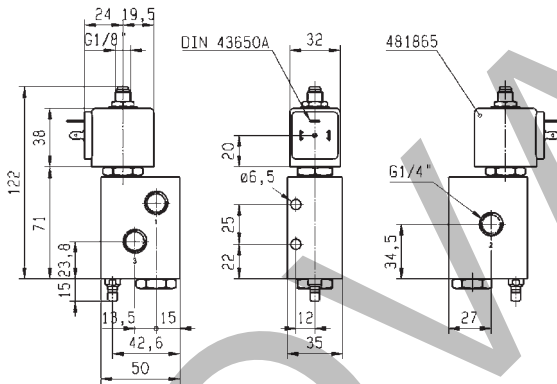

Weight: 0,51 kg

Drawing 3240

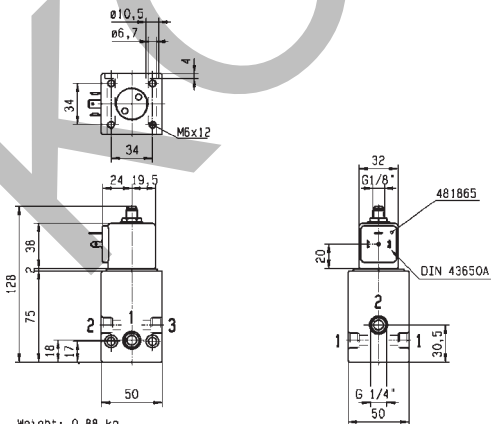

Weight: 0,88 kg

Drawing 3234

3/2

VALVES FOR DRY OR LUBRICATED AIR, NEUTRAL GASES AND LIQUIDS
PILOT OPERATED

ANODIZED ALUMINIUM

PIPE MOUNTING

NORMALLY CLOSED

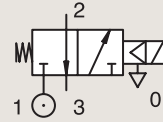

Port size	Orifice Ø		Flow factors			Operating Pressure Differential			Fluid Temp.		Seat Seal	Valve Ref.	Housing Ref.	Coil Ref.	Power		Coil Group	Dwg. No.	
	1	(2)	1	(2)	1	(2)	Min	Max (MOPD)	Min	Max					AC W	DC W			
BSP	mm		Kv l/min		Q l/min	bar	AC bar	DC bar	°C	°C									
1/2"	14	14	-	-	2500	2500	1	15	-	-10	75	NBR	E331B21 ₁	2995	482722	-	-	2.1	3238
	14	14	-	-	2500	2500	1	15	15	-10	65	NBR	E331B21 ₁	-	483371	8	8	2.1	3238

Notes:

1. Valve only compatible with air and neutral gases
2. Valve only compatible with hydraulic oil and air/neutral gases
3. With manual override

ANODIZED ALUMINIUM

PIPE MOUNTING

NORMALLY OPEN

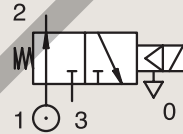

Port size	Orifice Ø		Flow factors			Operating Pressure Differential			Fluid Temp.		Seat Seal	Valve Ref.	Housing Ref.	Coil Ref.	Power		Coil Group	Dwg. No.	
	1	(2)	1	(2)	1	(2)	Min	Max (MOPD)	Min	Max					AC W	DC W			
BSP	mm		Kv l/min		Q l/min	bar	AC bar	DC bar	°C	°C									
1/4"	8	8	10	10	750	750	1	40	40	-10	75	NBR	332B02 ₂₃	2995	481865	8	9	2.1	8114
	8	8	10	10	750	750	1	40	40	-10	75	NBR	332B02 ₂₃	4270	481000	8	8	2.1	8114
	8	8	20	20	1100	1100	1	15	15	-10	75	NBR	E332B01 ₃	2995	481865	8	9	2.1	3234
	8	8	20	20	1100	1100	1	15	15	-10	75	NBR	E332B01 ₃	4270	481000	8	8	2.1	3234
	8	8	20	20	1100	1100	1	15	15	-10	65	NBR	E332B01 ₃	-	483371	8	8	2.1	3234

Notes:

1. Valve only compatible with air and neutral gases
2. Pilot seat discs in Kel-F (PCTFE); valve with pilot return pipe
3. Valve only compatible with hydraulic oil and air/neutral gases



For this page	Port size	Orifice (mm)	Kv (l/min)	MOPD (bar)	Fluid Temp (°C)
From	1/4"	8	10	15	-10
To	1/4"	14	20	40	75

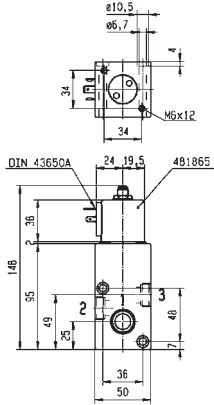

Weight: 0,98 ka

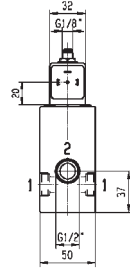

Drawing 3238

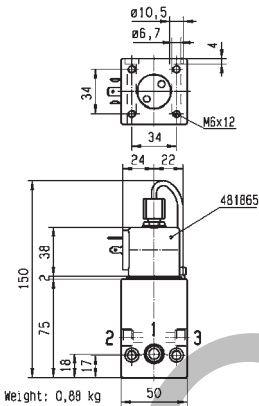

Weight: 0,88 kg

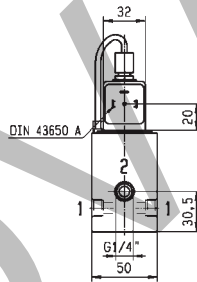

Drawing 8114

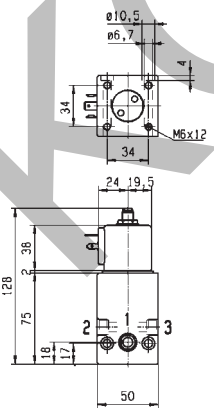

Weight: 0,88 ka

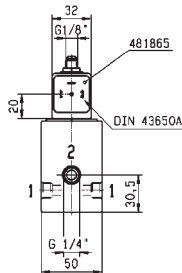

Drawing 3234

3/2

VALVES FOR DRY OR LUBRICATED AIR, NEUTRAL GASES AND LIQUIDS
PILOT OPERATED

ANODIZED ALUMINIUM

PIPE MOUNTING

NORMALLY OPEN

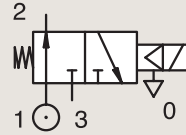

Port size	Orifice Ø		Flow factors			Operating Pressure Differential			Fluid Temp.		Seat Seal	Valve Ref.	Housing Ref.	Coil Ref.	Power		Coil Group	Dwg. No.	
	1	(2)	1	(2)	1	(2)	Min	Max (MOPD)	Min	Max					AC W	DC W			
BSP	mm		Kv l/min	Q l/min	bar	AC bar	DC bar	°C	°C										
1/2"	14	14	37.5	-	2500	2500	1	15	15	-10	75	NBR	E332B21	2995	481865	8	9	2.1	3238
	14	14	37.5	-	2500	2500	1	15	15	-10	75	NBR	E332B21	4270	481000	8	8	2.1	3238

Notes:

- 1.Valve only compatible with air and neutral gases
- 2.With manual override

ANODIZED ALUMINIUM

SUB-BASE MOUNTING

NORMALLY CLOSED

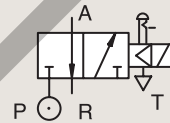

Port size	Orifice Ø	Flow factor	Operating Pressure Differential			Fluid Temp.		Seat Seal	Valve Ref.	Housing Ref.	Coil Ref.	Power		Coil Group	Dwg. No.
			Min	Max (MOPD)	Min	Max	AC W					DC W			
	1	Qn l/min	bar	AC bar	DC bar	°C	°C								
SB	15	5000	0.5	10	10	-10	75	NBR	E331L21 ₁₂	2995	481865	8	9	2.1/3.0	3130
	15	5000	0.5	10	10	-10	65	NBR	E331L21 ₁₂	-	483371	8	8	2.1/3.0	3130

Notes:

- 1.Valve only compatible with air and neutral gases
- 2.With manual override



For this page	Port size	Orifice (mm)	Qn (l/min)	MOPD (bar)	Fluid Temp (°C)
From	1/2"	14	-	10	-10
To	1/2"	15	5000	15	75

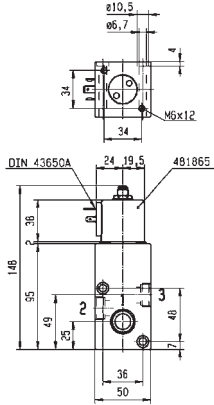

Weight: 0.98 ka

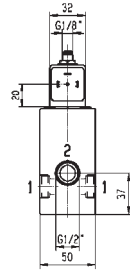

Drawing 3238

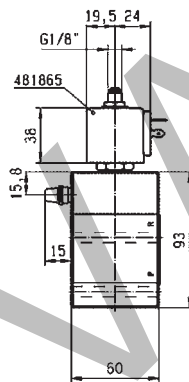
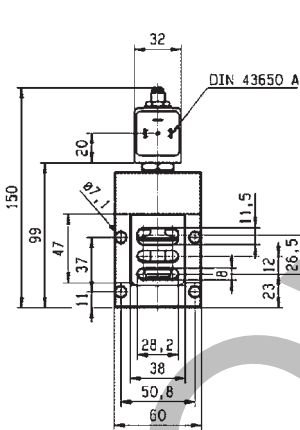

Drawing 3130



VALVES FOR HYDRAULIC OIL AND NEUTRAL LIQUIDS (UP TO 75 BAR)

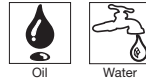

3/2

Actuation	Body	Function	Port Size	Orifice (mm)	Flow Factor Kv(l/min)	MOPD (bar)	Max Fluid Temp. (°C)	Page Parker Valve
Pilot Operated	Anodized Aluminium/ Pipe Mounting	Normally Closed	1/4"	8	10	40	75	210

KOVALAVI

3/2

VALVES FOR HYDRAULIC OIL AND NEUTRAL LIQUIDS (UP TO 75 BAR) PILOT OPERATED

ANODIZED ALUMINIUM

PIPE MOUNTING

NORMALLY CLOSED

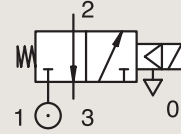

Port size	Orifice Ø		Flow factors			Operating Pressure Differential			Fluid Temp.		Seat Seal	Valve Ref.	Housing Ref.	Coil Ref.	Power		Coil Group	Dwg. No.	
	1	(2)	1	(2)	1	(2)	Min	Max (MOPD)	DC	Min					Max	AC W			DC W
BSP	mm		Kv l/min	KV m³/h	bar	AC bar	DC bar	°C	°C										
1/4"	8	8	10	10	0.6	0.6	1	40	40	-10	75	NBR	331B02 ₁₂	2995	481865	8	9	2.1	8114
	8	8	10	10	0.6	0.6	1	40	40	-10	75	NBR	331B02 ₁₂	4270	481000	8	8	2.1	8114
	8	8	10	10	0.6	0.6	1	40	40	-10	75	NBR	331B0216 ₁₃	2995	481865	8	9	2.1	8114
	8	8	10	10	0.6	0.6	1	40	40	-10	75	NBR	331B0216 ₁₃	4270	481000	8	8	2.1	8114

Notes:

- 1. Pilot seat discs in Kel-F (PCTFE); valve with pilot return pipe
- 2. Valve only compatible with hydraulic oil
- 3. Pilot seat disk in PUR; valve only compatible with air/neutral gases

KONVA



For this page	Port size	Orifice (mm)	Kv (l/min)	MOPD (bar)	Fluid Temp (°C)
From	1/4"	8	10	40	-10
To	1/4"	8	10	40	75

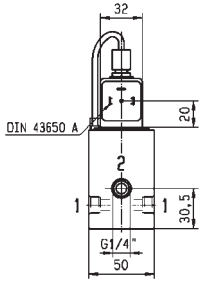
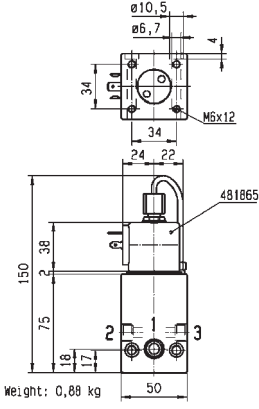

Drawing 8114

KOLVAN



HIGH CORROSION RESISTANT VALVES (303 STAINLESS ST.)



3/2

Actuation	Body	Function	Port Size	Orifice (mm)	Flow Factor Kv(l/min)	MOPD (bar)	Max Fluid Temp. (°C)	Page Parker Valve
Direct Operated	303 Stainless St./Pipe Mounting	Normally Closed	1/4"	1 to 2.5	3	15	180	214
		Universal	1/4"	1.5 to 2.5	3.5	10	180	216

KOVALAVI

3/2

HIGH CORROSION RESISTANT VALVES (303 STAINLESS ST.) DIRECT OPERATED

303 STAINLESS ST.
PIPE MOUNTING

NORMALLY CLOSED

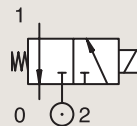

Port size	Orifice Ø		Flow factors				Operating Pressure Differential			Fluid Temp.		Seat Seal	Valve Ref.	Housing Ref.	Coil Ref.	IS	Power		Coil Group	Dwg. No.
	1	(2)	1	(2)	1	(2)	Min	Max (MOPD)	Max	Min	Max						AC W	DC W		
BSP	mm		Kv l/min		KV m³/h		bar	bar	bar	°C	°C									
1/4"	1	1	0.6	0.6	0.04	0.04	0	-	10	-10	55	FKM	131V5490	2995	48358001	*	-	0.5-3	7.0/8.0	6740
	1	1	0.6	0.6	0.04	0.04	0	-	10	-10	75	FKM	131V5490	-	495910	*	-	0.3-1.2	7.0/8.0	6740
	1.5	1.5	1.5	1.5	0.09	0.09	0	15	15	-10	120	FKM	131V5406	4270	481000		8	8	2.1	8116
	1.5	1.5	1.5	1.5	0.09	0.09	0	15	15	-10	100	FKM	131V5406	2995	481865		8	9	2.1	8116
	1.5	1.5	1.5	1.5	0.09	0.09	0	15	15	0	130	Ruby	131V5463 ₁	4270	481000		8	8	2.0	8116
	1.5	1.5	1.5	1.5	0.09	0.09	0	15	15	0	100	Ruby	131V5463 ₁	2995	481865		8	9	2.0	8116
	1.5	1.5	1.5	1.5	0.09	0.09	0	15	15	0	180	Ruby	131V5463 ₁	4270	486265		14	14	2.0	8116
	1.5	1.5	1.5	1.5	0.09	0.09	0	-	7	-20	75	PUR	131V5497	2995	482740		-	1.6	6.0/8.0	8024
	1.5	1.5	1.5	1.5	0.09	0.09	0	7	7	-20	75	PUR	131V5497	-	495900		2.5	2	6.0/8.0	8024
	1.5	1.5	1.5	1.5	0.09	0.09	0	-	7	-20	75	PUR	131V5497	-	495910	*	-	0.3-1.2	6.0/8.0	8024
	1.5	1.5	1.5	1.5	0.09	0.09	0	-	7	-20	65	PUR	131V5497	2995	496125		-	1.6	6.0/8.0	8024
	2.5	2.5	3.5	3.5	0.21	0.21	0	7	7	-10	120	FKM	131V5306	4270	481000		8	8	2.1	8116
	2.5	2.5	3.5	3.5	0.21	0.21	0	7	7	-10	100	FKM	131V5306	2995	481865		8	9	2.1	8116
	2.5	2.5	3.5	3.5	0.21	0.21	0	7	7	-30	130	Ruby	131V5363 ₁	4270	481000		8	8	2.0	8116
	2.5	2.5	3.5	3.5	0.21	0.21	0	7	7	-30	100	Ruby	131V5363 ₁	2995	481865		8	9	2.0	8116
	2.5	2.5	3.5	3.5	0.21	0.21	0	7	7	-30	180	Ruby	131V5363 ₁	4270	486265		14	14	2.0	8116
	2.5	2.5	3	3	0.18	0.18	0	-	2	-20	75	PUR	131V5397	2995	482740		-	1.6	6.0/8.0	8024
	2.5	2.5	3	3	0.18	0.18	0	2	2	-20	75	PUR	131V5397	-	495900		2.5	2	6.0/8.0	8024
	2.5	2.5	3	3	0.18	0.18	0	-	2	-20	75	PUR	131V5397	-	495910	*	-	0.3-1.2	6.0/8.0	8024
	2.5	2.5	3	3	0.18	0.18	0	-	2	-20	65	PUR	131V5397	2995	496125		-	1.6	6.0/8.0	8024
1/4" NPT	1	1	0.6	0.6	0.04	0.04	0	-	10	-10	55	FKM	U131V5490	2995	483580.01	*	-	0.5-3	7.0/8.0	6740
	1.5	1.5	1.5	1.5	0.09	0.09	0	15	15	-10	100	FKM	U131V5406	2995	481865		8	9	2.1	8116
	1.5	1.5	1.5	1.5	0.09	0.09	0	15	15	0	100	Ruby	U131V5463 ₁	2995	481865		8	9	2.0	8116
	2.5	2.5	3.5	3.5	0.21	0.21	0	7	7	-10	100	FKM	U131V5306	2995	481865		8	9	2.1	8116
2.5	2.5	3.5	3.5	0.21	0.21	0	7	7	-30	100	Ruby	U131V5363 ₁	2995	481865		8	9	2.0	8116	

Notes:

1. Valve only compatible with hydraulic oil and neutral liquids



For this page	Port size	Orifice (mm)	Kv (l/min)	MOPD (bar)	Fluid Temp (°C)
From	1/4"	1	0.6	2	-30
To	1/4"	2.5	3.5	15	180

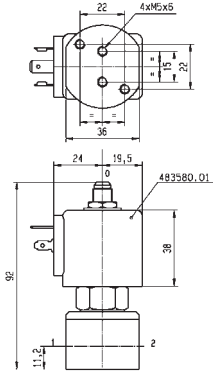

WEIGHT: 0.410 Kg

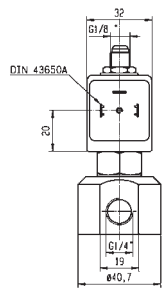

Drawing 6740

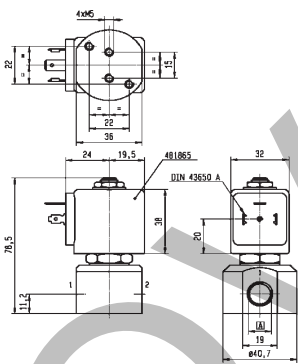

A G 1/8"
G 3/4"



Drawing 8116

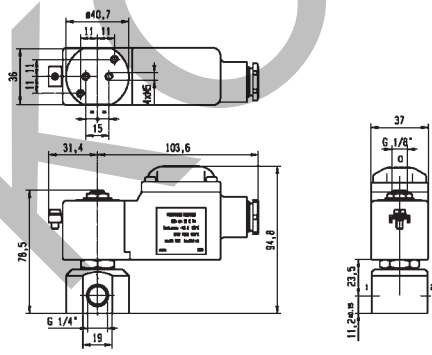

Drawing 8024

3/2

HIGH CORROSION RESISTANT VALVES (303 STAINLESS ST.) DIRECT OPERATED

303 STAINLESS ST.

PIPE MOUNTING

UNIVERSAL

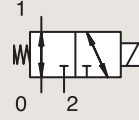

Port size	Orifice Ø		Flow factors			Operating Pressure Differential			Fluid Temp.		Seat Seal	Valve Ref.	Housing Ref.	Coil Ref.	Power		Coil Group	Dwg. No.	
	1	(2)	1	(2)	1	(2)	Min	Max (MOPD)	Min	Max					AC W	DC W			
BSP	mm		Kv l/min		KV m³/h		bar	AC bar	DC bar	°C	°C								
1/4"	1.5	1.5	1.5	1.5	0.09	0.09	0	10	10	-10	120	FKM	133V5406	4270	481000	8	8	2.1	8116
	1.5	1.5	1.5	1.5	0.09	0.09	0	10	10	-10	100	FKM	133V5406	2995	481865	8	9	2.1	8116
	1.5	1.5	1.5	1.5	0.09	0.09	0	10	10	0	130	Ruby	133V5463	4270	481000	8	8	2.0	8116
	1.5	1.5	1.5	1.5	0.09	0.09	0	10	10	0	100	Ruby	133V5463	2995	481865	8	9	2.0	8116
	1.5	1.5	1.5	1.5	0.09	0.09	0	10	10	0	180	Ruby	133V5463	4270	486265	14	14	2.0	8116
	2.5	2.5	3.5	3.5	0.21	0.21	0	4	4	-10	120	FKM	133V5306	4270	481000	8	8	2.1	8116
	2.5	2.5	3.5	3.5	0.21	0.21	0	4	4	-10	100	FKM	133V5306	2995	481865	8	9	2.1	8116
	2.5	2.5	3.5	3.5	0.21	0.21	0	4	4	0	130	Ruby	133V5363	4270	481000	8	8	2.0	8116
	2.5	2.5	3.5	3.5	0.21	0.21	0	4	4	0	100	Ruby	133V5363	2995	481865	8	9	2.0	8116
1/4" NPT	1.5	1.5	1.5	1.5	0.09	0.09	0	10	10	-10	100	FKM	U133V5406	2995	481865	8	9	2.1	8116
	1.5	1.5	1.5	1.5	0.09	0.09	0	10	10	0	100	Ruby	U133V5463	2995	481865	8	9	2.0	8116
	2.5	2.5	3.5	3.5	0.21	0.21	0	4	4	-10	100	FKM	U133V5306	2995	481865	8	9	2.1	8116
	2.5	2.5	3.5	3.5	0.21	0.21	0	4	4	0	100	Ruby	U133V5363	2995	481865	8	9	2.0	8116

Notes:

1. Valve only compatible with hydraulic oil and neutral liquids



For this page	Port size	Orifice (mm)	Kv (l/min)	MOPD (bar)	Fluid Temp (°C)
From	1/4"	1.5	1.5	4	-10
To	1/4"	2.5	3.5	10	180

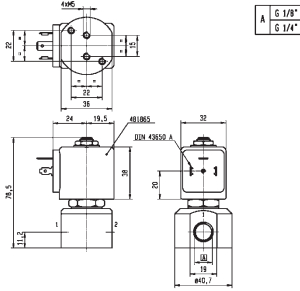

Drawing 8116

KOLVAR.COM

VALVES FOR BEVERAGE DISPENSING AND LIQUIPURE®



Steam



Water

3/2

Actuation	Body	Function	Port Size	Orifice (mm)	Flow Factor Kv(l/min)	MOPD (bar)	Max Fluid Temp. (°C)	Page Parker Valves
Direct Operated	Stainless St./Pipe Mounting	Normally Closed	1/8"	1.5 to 2.5	1 to 2.3	8	140	220
			1/4"	1.5 to 3	1 to 4.5	8	140	220
	LLB Brass/Pipe Mounting	Normally Closed	1/8"	1.5 to 3	1.4 to 3.7	20	140	222
			1/4"	1.5 to 5	1.4 to 4.3	20	140	224
	LLB Brass/Sub-Base Mounting	Normally Closed	SB	1.5 to 3	1.3 to 3.7	20	140	226
	Stainless St./Sub-base Mounting	Normally Closed	SB	1.5 to 5	7.2	14	140	228

3 WAY VALVES

3/2

VALVES FOR BEVERAGE DISPENSING -
LIQUIPURE®
DIRECT OPERATED

STAINLESS ST.

301LG SERIES - 3

NORMALLY CLOSED

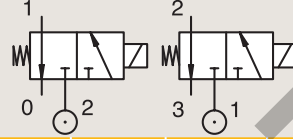

Port Size	Orifice	Flow Factors		Operating Pressure Differential			Fluid Temperature		Seat Seal	Parker Valves		Power		Coil Group	Fluid Compatibility
		kv l/min	Kv m³/h	Min. Bar	Max. (MOPD) AC bar	DC bar	Min. °C	Max. °C		Valve Ref.	Coil Ref.	AC W	DC W		
1/8"	1.5	1	0.06	0	8	8	-10	140	FKM	301LG1GVG2	481180	4	5	1.1/1.3	A 4
	2.5	2.3	0.14	0	3	3	-10	140	FKM	301LG1LVG2	481180	4	5	1.1/1.3	A 4
1/4"	1.5	1	0.06	0	8	8	-10	140	FKM	301LG2GVG2	481180	4	5	1.1/1.3	A 4
	2.5	2.3	0.14	0	3	3	-10	140	FKM	301LG2LVG2	481180	4	5	1.1/1.3	A 4
	1.5	1	0.06	0	12	12	-10	140	FKM	301LG2GVG7	481865	8	9	24/2.0	A 5
	3.0	4.5	0.27	0	4	4	-10	140	FKM	301LG2NVG7	481865	8	9	24/2.0	A 5

KONVA

3 WAY VALVES



For this page	Port size	Orifice (mm)	Kv (l/min)	MOPD (bar)	Fluid Temp (°C)
From	1/8"	1.5	1	3	-10
To	1/4"	3	4.5	8	140

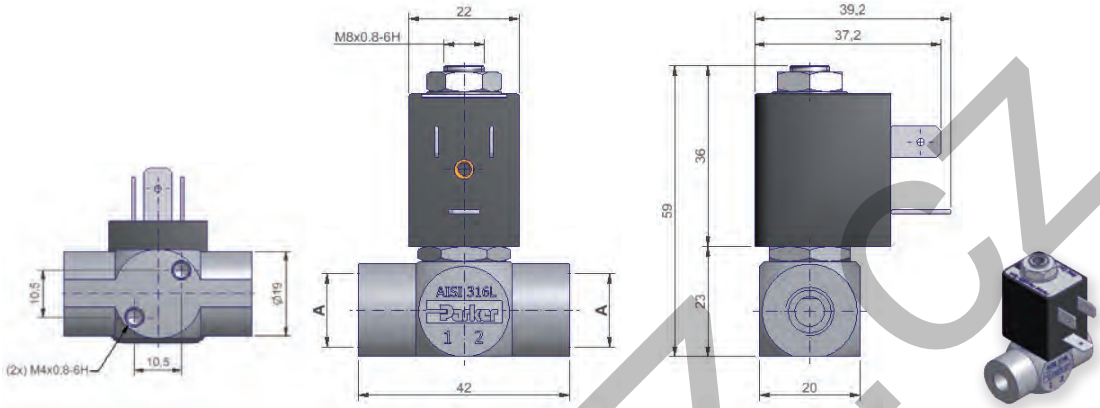

Drawing 4

All dimensions are in mm

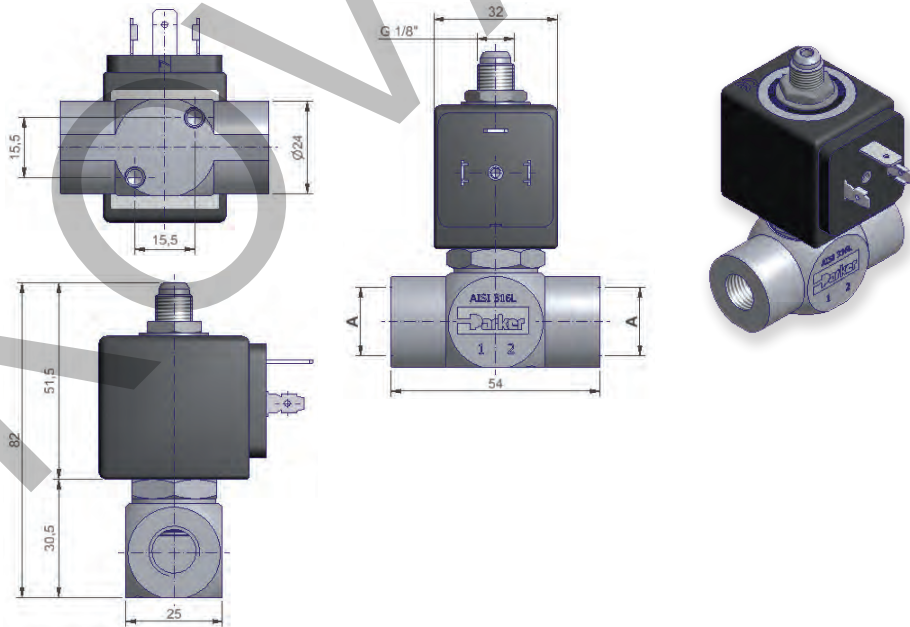

All dimensions are in mm

Drawing 5

3 WAY VALVES

3/2

VALVES FOR BEVERAGE DISPENSING - LIQUIPURE® DIRECT OPERATED

Our Parker range of healthy solenoid valves provides you with top-class performance as a result of the entire stainless steel structure of the valve pilots.

Compact and robust at the same time, the stainless steel nozzle included in all 32mm operated range improves valve life, endurance and resistance to lime-scale build up effect. A wide range of electrical parts can be used with this valve, including IP65 VDE and UL solutions. Typical applications include cold water loading function or hot water-steam on/off control.

Valve body: forged brass, CW510L UNI EN 12165

Seals: FDA FKM, Ruby

Sleeve, plungers and nozzle: stainless steel



CW510L BRASS BODY PIPE MOUNTING

NORMALLY CLOSED

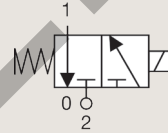

Port Size	Orifice Ø mm	Flow Factors		Operating Pressure Differential			Fluid Temperature		Seat Seal	Parker Valves			Power		Coil Group	Dwg N°
		Kv l/min	KV m³/h	Min. Bar	Max. (MOPD) AC bar	DC bar	Min. °C	Max. °C		Valve Ref.	Housing Ref.	Coil Ref.	AC W	DC W		
G1/8"	1.5	1.4	0.08	0	20	20	-10	140	FDA FKM	131ZH1115	2995	481865	9	8	2.0, 2.1, 2.2	5
	2.0	2.0	0.12	0	14	14	-10	140	FDA FKM	131ZH1120	2995	481865	9	8	2.0, 2.1, 2.2	
	2.5	3.0	0.18	0	8.5	8.5	-10	140	FDA FKM	131ZH1125	2995	481865	9	8	2.0, 2.1, 2.2	
	3.0	3.7	0.22	0	6	6	-10	140	FDA FKM	131ZH1130	2995	481865	9	8	2.0, 2.1, 2.2	
	1.5	1.4	0.08	0	20	20	-10	140	Ruby	131ZH1115	2995	481865	9	8	2.0, 2.1, 2.2	
	2.0	2.0	0.12	0	14	14	-10	140	Ruby	131ZH1120	2995	492425	9	8	2.0, 2.1, 2.2	
	2.5	3.0	0.18	0	8.5	8.5	-10	140	Ruby	131ZH0125	2995	481865	9	8	2.0, 2.1, 2.2	
G1/8"	3.0	3.7	0.22	0	6	6	-10	140	Ruby	131ZH0130	2995	481865	9	8	2.0, 2.1, 2.2	6
	1.5	1.4	0.10	0	20	20	-10	140	FDA FKM	131ZH1315	2995	481865	9	8	2.0, 2.1, 2.2	
	2.0	2.0	0.10	0	14	14	-10	140	FDA FKM	131ZH1320	2995	481865	9	8	2.0, 2.1, 2.2	
	2.5	3.0	0.20	0	8.5	8.5	-10	140	FDA FKM	131ZH1325	2995	481865	9	8	2.0, 2.1, 2.2	
	3.0	3.7	0.20	0	6	6	-10	140	FDA FKM	31ZH1330	2995	481865	9	8	2.0, 2.1, 2.2	
	1.5	1.4	0.1	0	20	20	-10	140	Ruby	131ZH0315	2995	481865	9	8	2.0, 2.1, 2.2	
	2.0	2.0	0.1	0	14	14	-10	140	Ruby	131ZH0320	2995	481865	9	8	2.0, 2.1, 2.2	
NPT 1/8"	2.5	3.0	0.2	0	8.5	8.5	-10	140	Ruby	131ZH0325	2995	481865	9	8	2.0, 2.1, 2.2	5
	3.0	3.7	0.2	0	6	6	-10	140	Ruby	131ZH0330	2995	481865	9	8	2.0, 2.1, 2.2	
	1.5	1.4	0.08	0	20	20	-10	140	FDA FKM	U131ZH1115	2995	481865	9	8	2.0, 2.1, 2.2	
	2.0	2.0	0.12	0	14	14	-10	140	FDA FKM	U131ZH1120	2995	481865	9	8	2.0, 2.1, 2.2	
	2.5	3.0	0.18	0	8.5	8.5	-10	140	FDA FKM	U131ZH1125	2995	481865	9	8	2.0, 2.1, 2.2	
	3.0	3.7	0.22	0	6	6	-10	140	FDA FKM	U131ZH1130	2995	481865	9	8	2.0, 2.1, 2.2	
	1.5	1.4	0.08	0	20	20	-10	140	Ruby	U131ZH0115	2995	481865	9	8	2.0, 2.1, 2.2	
2.0	2.0	0.12	0	14	14	-10	140	Ruby	U131ZH0120	2995	481865	9	8	2.0, 2.1, 2.2		
2.5	3.0	0.18	0	8.5	8.5	-10	140	Ruby	U131ZH0125	2995	481865	9	8	2.0, 2.1, 2.2		
3.0	3.7	0.22	0	6	6	-10	140	Ruby	U131ZH0130	2995	481865	9	8	2.0, 2.1, 2.2		

3 WAY VALVES



For this page	Port size	Orifice (mm)	Kv (l/min)	MOPD (bar)	Fluid Temp (°C)
From	1/8"	1.5	1.4	6	-10
To	1/4"	3	3.7	20	140
From	SB	1.5	1.3	7.5	-10
To	SB	3	3	20	140

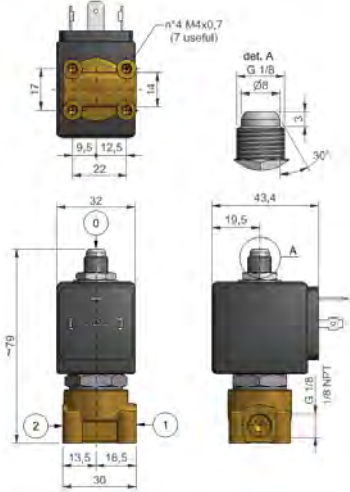

Drawing 5

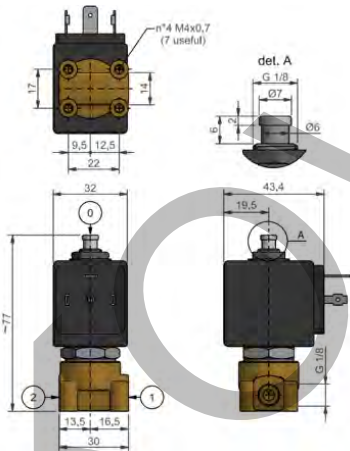

Drawing 6

3 WAY VALVES

3/2

VALVES FOR BEVERAGE DISPENSING - LIQUIPURE® DIRECT OPERATED

Our Parker range of healthy solenoid valves provides you with top-class performance as a result of the entire stainless steel structure of the valve pilots.

Compact and robust at the same time, the stainless steel nozzle included in all 32mm operated range improves valve life, endurance and resistance to lime-scale build up effect. A wide range of electrical parts can be used with this valve, including IP65 VDE and UL solutions. Typical applications include cold water loading function or hot water-steam on/off control.

Valve body: forged brass, CW510L UNI EN 12165

Seals: FDA FKM, Ruby

Sleeve, plungers and nozzle: stainless steel



CW510L BRASS BODY PIPE MOUNTING

NORMALLY CLOSED

Port Size	Orifice Ø		Flow Factors		Operating Pressure Differential			Fluid Temperature		Seat Seal	Parker Valves			Power		Coil Group	Dwg N°
	mm	mm	Kv l/min	KV m³/h	Min. Bar	Max. (MOPD) AC bar	DC bar	Min. °C	Max. °C		Valve Ref.	Housing Ref.	Coil Ref.	AC W	DC W		
G1/4"	1.5	1.4	0.08	0	20	20	20	-10	140	FDA FKM	131KH1115	2995	481865	9	8	2.0, 2.1, 2.2	7
	2.0	2.0	0.12	0	14	14	14	-10	140	FDA FKM	131KH1120	2995	481865	9	8	2.0, 2.1, 2.2	
	2.5	3.0	0.18	0	8.5	8.5	8.5	-10	140	FDA FKM	131KH1125	2995	481865	9	8	2.0, 2.1, 2.2	
	3.0	3.7	0.22	0	6	6	6	-10	140	FDA FKM	131KH1130	2995	481865	9	8	2.0, 2.1, 2.2	8
	4.0	5.2	0.31	0	3.5	3.5	3.5	-10	140	FDA FKM	131KH1140	2995	481865	9	8	2.0, 2.1, 2.2	
G1/4"	5.0	9.3	0.56	0	2	2	2	-10	140	FDA FKM	131KH1150	2995	492425	14	14	2.0, 2.1, 2.2	7
	1.5	1.4	0.08	0	20	20	20	-10	140	Ruby	131KH0115	2995	481865	9	8	2.0, 2.1, 2.2	
	2.0	2.0	0.12	0	14	14	14	-10	140	Ruby	131KH0120	2995	481865	9	8	2.0, 2.1, 2.2	
	2.5	3.0	0.18	0	8.5	8.5	8.5	-10	140	Ruby	131KH0125	2995	481865	9	8	2.0, 2.1, 2.2	
	3.0	3.7	0.22	0	6	6	6	-10	140	Ruby	131KH0130	2995	481865	9	8	2.0, 2.1, 2.2	

3 WAY VALVES



For this page	Port size	Orifice (mm)	Kv (l/min)	MOPD (bar)	Fluid Temp (°C)
From	1/8"	1.5	1.4	6	-10
To	1/4"	3	3.7	20	140
From	SB	1.5	1.3	7.5	-10
To	SB	3	3	20	140

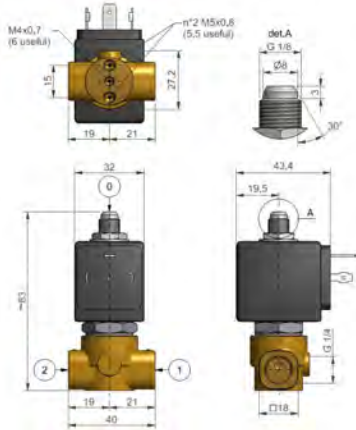

Drawing 7

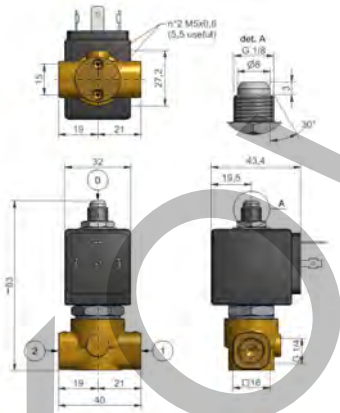

Drawing 8

3 WAY VALVES

3/2

VALVES FOR BEVERAGE DISPENSING - LIQUIPURE® DIRECT OPERATED

Our Parker range of healthy solenoid valves provides you with top-class performance as a result of the entire stainless steel structure of the valve pilots.

Compact and robust at the same time, the stainless steel nozzle included in all 32mm operated range improves valve life, endurance and resistance to lime-scale build up effect. A wide range of electrical parts can be used with this valve, including IP65 VDE and UL solutions. Typical applications include cold water loading function or hot water-steam on/off control.

Valve body: forged brass, CW510L UNI EN 12165

Seals: FD A FKM, Ruby

Sleeve, plungers and nozzle: stainless steel



CW510L BRASS BODY FLANGED (SB)

NORMALLY CLOSED

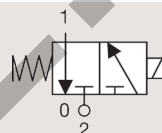

Port Size	Orifice Ø mm	Flow Factors		Operating Pressure Differential			Fluid Temperature		Seat Seal	Parker Valves			Power		Coil Group	Dwg N°
		Kv l/min	KV m³/h	Min. Bar	Max. (MOPD) AC bar	DC bar	Min. °C	Max. °C		Valve Ref.	Housing Ref.	Coil Ref.	AC W	DC W		
SB	1.5	1.4	0.08	0	20	20	-10	140	FDA FKM	131FH1115	2995	481865	9	8	2.0, 2.1, 2.2	9
	2.0	2.0	0.12	0	15	15	-10	140	FDA FKM	131FH1120	2995	481865	9	8	2.0, 2.1, 2.2	
	2.5	3.0	0.16	0	10	10	-10	140	FDA FKM	131FH1125	2995	481865	9	8	2.0, 2.1, 2.2	
	3.0	3.7	0.18	0	7.5	7.5	-10	140	FDA FKM	131FH1130	2995	481865	9	8	2.0, 2.1, 2.2	
	1.5	1.4	0.08	0	20	20	-10	140	Ruby	131FH1115	2995	481865	9	8	2.0, 2.1, 2.2	
	2.0	2.0	0.12	0	15	15	-10	140	Ruby	131FH1120	2995	481865	9	8	2.0, 2.1, 2.2	
	2.5	3.0	0.16	0	10	10	-10	140	Ruby	131FH1125	2995	481865	9	8	2.0, 2.1, 2.2	
	3.0	3.7	0.18	0	7.5	7.5	-10	140	Ruby	131FH1130	2995	481865	9	8	2.0, 2.1, 2.2	
SB	1.5	1.4	0.08	0	20	20	-10	140	FDA FKM	131FH1315	2995	481865	9	8	2.0, 2.1, 2.2	10
	2.0	2.0	0.12	0	15	15	-10	140	FDA FKM	131FH1320	2995	481865	9	8	2.0, 2.1, 2.2	
	2.5	3.0	0.16	0	10	10	-10	140	FDA FKM	131FH1325	2995	481865	9	8	2.0, 2.1, 2.2	
	3.0	3.7	0.18	0	7.5	7.5	-10	140	FDA FKM	131FH1330	2995	481865	9	8	2.0, 2.1, 2.2	
	1.5	1.4	0.08	0	20	20	-10	140	Ruby	131FH0315	2995	481865	9	8	2.0, 2.1, 2.2	
	2.0	2.0	0.12	0	15	15	-10	140	Ruby	131FH0320	2995	481865	9	8	2.0, 2.1, 2.2	
	2.5	3.0	0.16	0	10	10	-10	140	Ruby	131FH0325	2995	481865	9	8	2.0, 2.1, 2.2	
	3.0	3.7	0.18	0	7.5	7.5	-10	140	Ruby	131FH0330	2995	481865	9	8	2.0, 2.1, 2.2	

3 WAY VALVES



For this page	Port size	Orifice (mm)	Kv (l/min)	MOPD (bar)	Fluid Temp (°C)
From	1/8"	1.5	1.4	6	-10
To	1/4"	3	3.7	20	140
From	SB	1.5	1.3	7.5	-10
To	SB	3	3	20	140

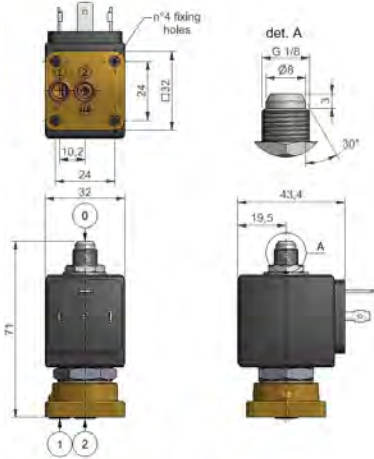

Drawing 9

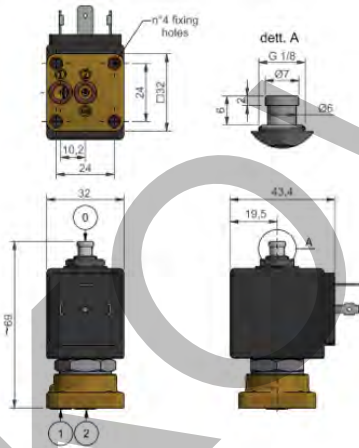

Drawing 10

3/2

VALVES FOR BEVERAGE DISPENSING - LIQUIPURE® DIRECT OPERATED



Beverage Dispensing



Medical / Instrumentation

STAINLESS ST. SUB-BASE MOUNTING

NORMALLY CLOSED

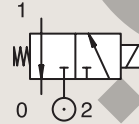

Port size	Orifice Ø		Flow factors		Operating Pressure Differential		Fluid Temp.		Seat Seal	Parker Valves			Power		Coil Group	Dwg. No.	Compatible adapter kit			
	1	(2)	1	(2)	Min	Max	Min	Max		Valve Ref.	Hou Ref.	Coil Ref.	AC W	DC W						
BSP	1.5	2.5	1.3	2.9	0.08	0.17	0	14	14	-10	140	Ruby	3019F1GRG7	-	481865	8	9	2.0	72	XGSPG1-XGSPG2
	1.5	2.5	1.3	2.9	0.08	0.17	0	14	14	-10	140	FKM FDA	3019F1GVG7	-	481865	8	9	2.0	72	XGSPG1-XGSPG2
	2	2.5	2.2	2.9	0.13	0.17	0	10	10	-10	140	Ruby	3019F1JRG7	-	481865	8	9	2.0	72	XGSPG1-XGSPG2
	2	2.5	2.2	2.9	0.13	0.17	0	10	10	-10	140	FKM FDA	3019F1JVG7	-	481865	8	9	2.0	72	XGSPG1-XGSPG2
	2	2.5	2.2	2.9	0.13	0.17	0	10	10	-10	140	Ruby	301XGFRTJ7	-	481865	8	9	2.0	72	XGSPG1-XGSPG2
	2.5	2.5	2.8	2.9	0.17	0.17	0	6.5	6.5	-10	140	Ruby	3019F1LRG7	-	481865	8	9	2.0	72	XGSPG1-XGSPG2
SB	2.5	2.5	2.8	2.9	0.17	0.17	0	6.5	6.5	-10	140	FKM FDA	3019F1LVG7	-	481865	8	9	2.0	72	XGSPG1-XGSPG2
	3	2.5	3.3	2.9	0.2	0.17	0	4	4	-10	140	Ruby	3019F1NRG7	-	481865	8	9	2.0	72	XGSPG1-XGSPG2
	3	2.5	3.3	2.9	0.2	0.17	0	4	4	-10	140	FKM FDA	3019F1NVG7	-	481865	8	9	2.0	72	XGSPG1-XGSPG2
	4	2.5	6.5	2.9	0.39	0.17	0	3	3	-10	140	FKM FDA	3019F1QVG7	-	481865	8	9	2.0	72	XGSPG1-XGSPG2
	4	4.0	6.5	2.9	0.39	0.17	0	3	3	-10	140	EPDM	3019F1QEG7	-	481865	8	9	2.0	72	XGSPG1-XGSPG2
	5	2.5	7.2	2.9	0.43	0.17	0	2	2	-10	140	FKM FDA	3019F1SVG7	-	481865	8	9	2.0	72	XGSPG1-XGSPG2
	5	5.0	7.2	2.9	0.43	0.17	0	2	2	-10	140	EPDM	3019F1SEG7	-	481865	8	9	2.0	72	XGSPG1-XGSPG2

Important: pressure vessels included in this page are supplied with the standard 2995 housing integrated.



For this page	Port size	Orifice (mm)	Kv (l/min)	MOPD (bar)	Fluid Temp (°C)
From	SB	1.5	1.3	10	-10
To	SB	2	2.2	14	140

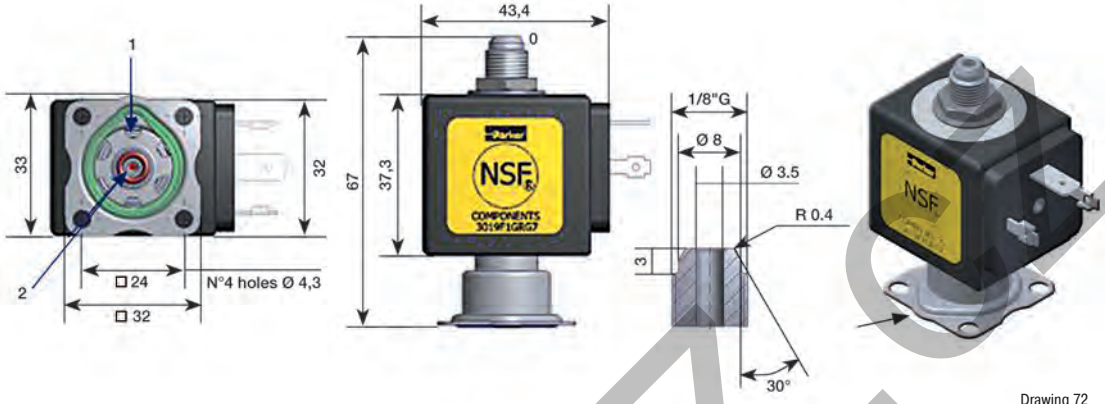

Drawing 72

KOVLAVI

3/2

VALVES FOR BEVERAGE DISPENSING - LIQUIPURE® DIRECT OPERATED

3/2 UNIVERSAL

1/8" G THREADED MALE EXHAUST PORT

NORMALLY CLOSED

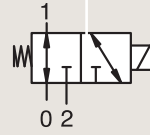

Port Size	Orifice mm		Flow Factors				Operating Pressure Differential			Fluid Temp.		Seat Seal	Reference		Power		Coil Group	Compatible Adapter Kit
	1	(2)	1		(2)		Min.	Max. (MOPD)		Min.	Max.		Valve Reference	Coil Ref.	AC W	DC W		
			Kv l/min	KV m³/h	Kv l/min	KV m³/h		bar	AC bar									
SB	1.5	1.5	1.4	0.08	1.3	0.8	0	9.5	9.5	-10	140	FKM FDA	3039F1GVG7	481865	9	8	24.0	XGSPG1 - XGSPG2
	1.5	1.5	1.4	0.08	1.3	0.08	0	9.5	9.5	-10	140	EPDM	3039F1GEG7	481865	9	8	24.0	XGSPG1 - XGSPG2
	2.0	2.0	2.1	0.13	2.0	0.12	0	3.5	3.5	-10	140	FKM FDA	3039F1JVG7	481865	9	8	24.0	XGSPG1 - XGSPG2
	2.0	2.0	2.1	0.13	2.0	0.12	0	3.5	3.5	-10	140	EPDM	3039F1JEG7	481865	9	8	24.0	XGSPG1 - XGSPG2
	2.5	2.5	2.8	0.17	2.8	0.17	0	2	2	-10	140	FKM FDA	3039F1LVG7	481865	9	8	24.0	XGSPG1 - XGSPG2
	2.5	2.5	2.8	0.17	2.8	0.168	0	2	2	-10	140	EPDM	3039F1LEG7	481865	9	8	24.0	XGSPG1 - XGSPG2
	3.0	2.5	3.3	0.2	2.8	0.17	0	2	2	-10	140	FKM FDA	3039F1NVG7	481865	9	8	24.0	XGSPG1 - XGSPG2
	3.0	2.5	3.3	0.2	2.8	0.168	0	2	2	-10	140	EPDM	3039F1NEG7	481865	9	8	24.0	XGSPG1 - XGSPG2

Nominal Pressure = 20 bar

Notes:

- 1. NSF Certified



For this page	Port size	Orifice (mm)	Kv (l/min)	MOPD (bar)	Fluid Temp (°C)
From	SB	1.5	1.4	2	-10
To	SB	3	3.3	9.5	140

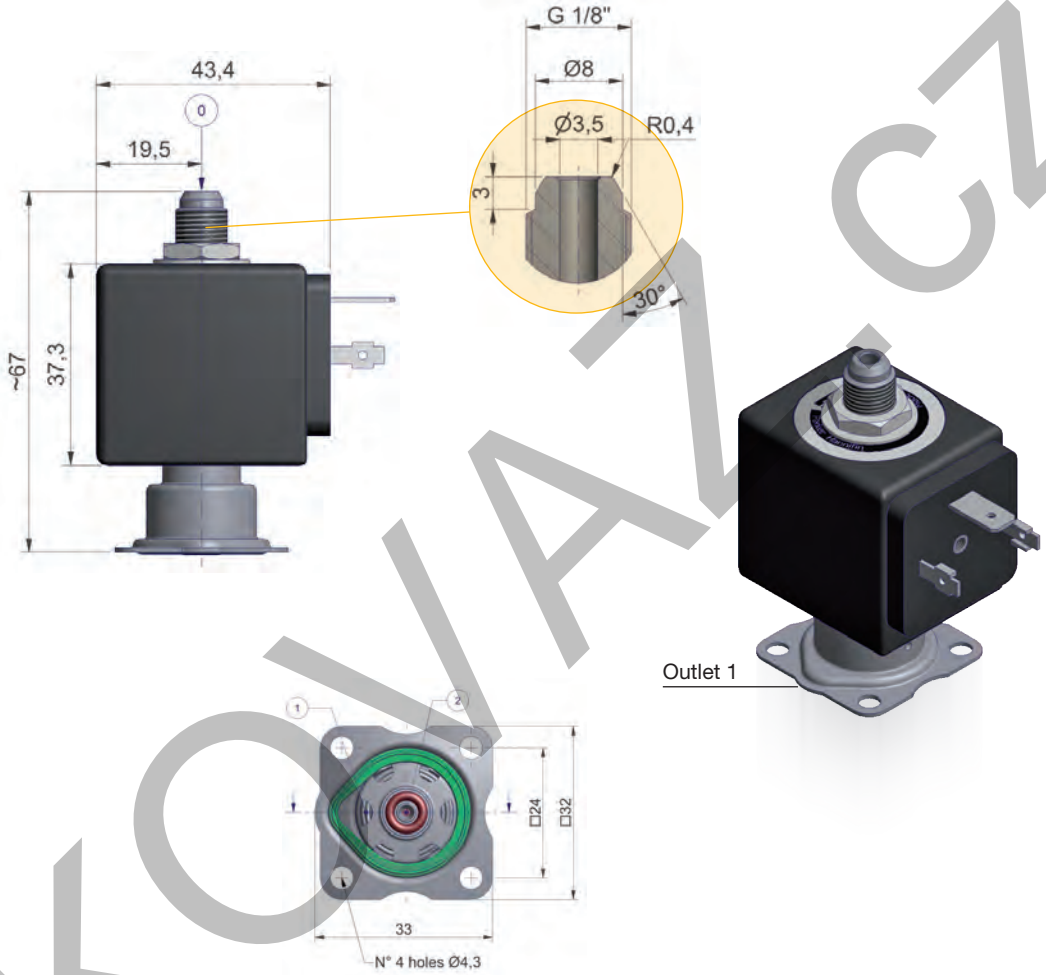

All dimensions are in mm

NOTES

KOVANZ.CZ

2 & 3 WAY VALVES FOR TRANSPORTATION



2 WAY VALVES FOR TRANSPORTATION



Water

2/2

Actuation	Body	Function	Port Size	Orifice (mm)	Flow Factor Kv(l/min)	MOPD (bar)	Max Fluid Temp. (°C)	Page Parker Valves
Pilot Operated	Brass/Quick Coupling	Normally Closed	10 mm	11	12	3	90	234
	Brass/Barb Fitting	Normally Closed	10 mm	11	12	3	90	234
	Brass/Pipe Mounting	Normally Closed	1/2"	11	36	3	90	236
			12.7 mm	11	33	3	90	236
			15.9 mm	11	36	3	90	236

KOVALAN

2/2

2 WAY VALVES FOR TRANSPORTATION

PILOT OPERATED



Transportation

BRASS

QUICK COUPLING

NORMALLY CLOSED

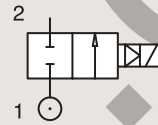

Port size	Orifice Ø mm	Flow factors			Operating Pressure Differential			Fluid Temp.		Seat Seal	Valve Ref.	Housing Ref.	Coil Ref.	Voltage		Power		Coil Group	Dwg. No.
		Kv l/min	KV m³/h	Qn l/min	Min bar	Max(MOPD) AC bar	DC bar	Min °C	Max °C					AC W	DC W				
		-	-	-	-	-	-	-	-										
10 mm	11	12	0.72	-	0.2	-	3	-40	90	EPDM	321K1543	2168	495294	12 VDC	-	9	13.0	8242	
	11	12	0.72	-	0.2	-	3	-40	90	EPDM	321K1543	2169	495294	24 VDC	-	9	13.0	8242	
	11	12	0.72	-	0.2	-	3	-40	90	EPDM	321K1543	2168	496193	12 VDC	-	9	13.0	8242	
	11	12	0.72	-	0.2	-	3	-40	90	EPDM	321K1543	2169	496193	24 VDC	-	9	13.0	8242	

BRASS

BARB FITTING

NORMALLY CLOSED

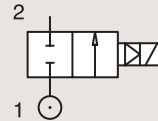

Port size	Orifice Ø mm	Flow factors			Operating Pressure Differential			Fluid Temp.		Seat Seal	Valve Ref.	Housing Ref.	Coil Ref.	Voltage		Power		Coil Group	Dwg. No.
		Kv l/min	KV m³/h	Qn l/min	Min bar	Max(MOPD) AC bar	DC bar	Min °C	Max °C					AC W	DC W				
		-	-	-	-	-	-	-	-										
10 mm	11	12	0.72	-	0.2	-	3	-40	90	EPDM	321K1535	2168	495294	12 VDC	-	9	13.0	8241	
	11	12	0.72	-	0.2	-	3	-40	90	EPDM	321K1535	2169	495294	24 VDC	-	9	13.0	8241	
	11	12	0.72	-	0.2	-	3	-40	90	EPDM	321K1535	2168	496193	12 VDC	-	9	13.0	8241	
	11	12	0.72	-	0.2	-	3	-40	90	EPDM	321K1535	2169	496193	24 VDC	-	9	13.0	8241	



For this page	Port size	Orifice (mm)	Kv (l/min)	MOPD (bar)	Fluid Temp (°C)
From	10 mm	11	12	3	-40
To	10 mm	11	12	3	90

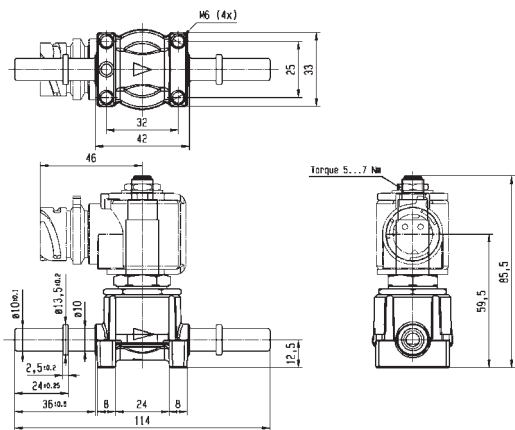

Drawing 8242

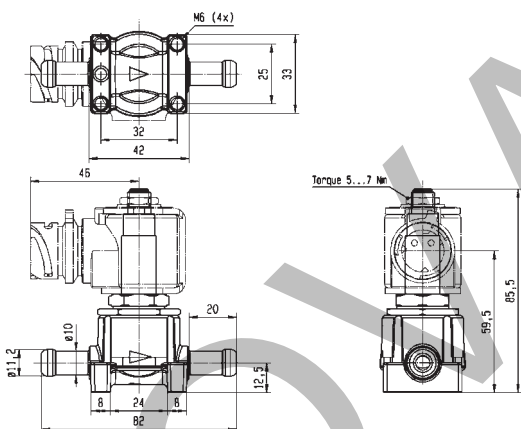

Drawing 8241



2/2

2 WAY VALVES FOR TRANSPORTATION

PILOT OPERATED

BRASS

PIPE MOUNTING

NORMALLY CLOSED

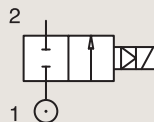

Port size	Orifice Ø mm	Flow factors			Operating Pressure Differential Max(MOPD)			Fluid Temp.		Seat Seal	Valve Ref.	Housing Ref.	Coil Ref.	Voltage	Power		Coil Group	Dwg. No.
		Kv l/min	KV m³/h	Qn l/min	Min bar	AC bar	DC bar	Min °C	Max °C						AC W	DC W		
1/2" BSP	11	36	2.16	-	0.2	-	3	-40	90	EPDM	321K1523	2168	495294	12 VDC	-	9	13.0	8238
	11	36	2.16	-	0.2	-	3	-40	90	EPDM	321K1523	2169	495294	24 VDC	-	9	13.0	8238
	11	36	2.16	-	0.2	-	3	-40	90	EPDM	321K1523	2168	496193	12 VDC	-	9	13.0	8238
	11	36	2.16	-	0.2	-	3	-40	90	EPDM	321K1523	2169	496193	24 VDC	-	9	13.0	8238
12.7 mm	11	33	1.98	-	0.2	-	3	-40	90	EPDM	321K1536	2168	495294	12 VDC	-	9	13.0	8282
	11	33	1.98	-	0.2	-	3	-40	90	EPDM	321K1536	2169	495294	24 VDC	-	9	13.0	8282
	11	33	1.98	-	0.2	-	3	-40	90	EPDM	321K1536	2168	496193	12 VDC	-	9	13.0	8282
	11	33	1.98	-	0.2	-	3	-40	90	EPDM	321K1536	2169	496193	24 VDC	-	9	13.0	8282
15.9 mm	11	36	2.16	-	0.2	-	3	-40	90	EPDM	321K1537	2168	495294	12 VDC	-	9	13.0	8281
	11	36	2.16	-	0.2	-	3	-40	90	EPDM	321K1537	2169	495294	24 VDC	-	9	13.0	8281
	11	36	2.16	-	0.2	-	3	-40	90	EPDM	321K1537	2168	496193	12 VDC	-	9	13.0	8281
	11	36	2.16	-	0.2	-	3	-40	90	EPDM	321K1537	2169	496193	24 VDC	-	9	13.0	8281



For this page	Port size	Orifice (mm)	Kv (l/min)	MOPD (bar)	Fluid Temp (°C)
From	1/2"	11	33	3	-40
To	15.9 mm	11	36	3	90

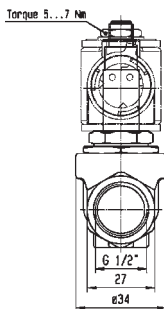
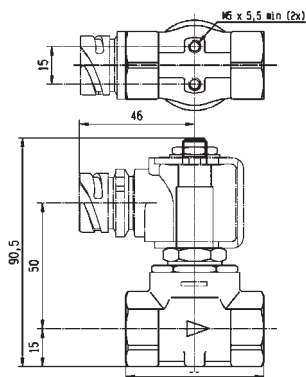

Drawing 8238

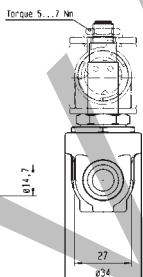
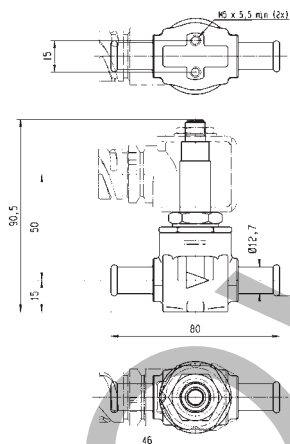

Drawing 8282

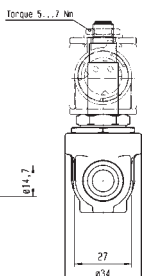
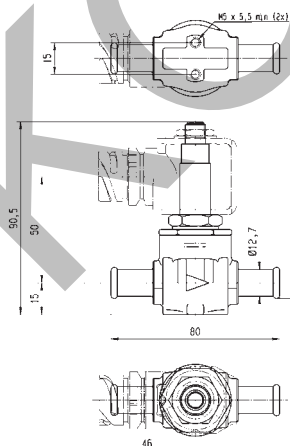

Drawing 8281

2 & 3 WAY VALVES FOR TRANSPORTATION

3 WAY VALVES FOR TRANSPORTATION



3/2

Actuation	Body	Function	Port Size	Orifice (mm)	Flow Factor Kv(l/min)	MOPD (bar)	Max Fluid Temp. (°C)	Page Parker Valves	Page
Direct Operated	Brass/Quick Coupling	Normally Closed	1/8"	1.8	110	8	80	-	240

KONVAVI

3/2

3 WAY VALVES FOR TRANSPORTATION

DIRECT OPERATED



Transportation

BRASS

QUICK COUPLING

NORMALLY CLOSED

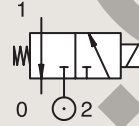

Port size	Orifice Ø		Flow factor Qn l/min	Operating Pressure Differential			Fluid Temp.		Seat Seal	Valve Ref.	Housing Ref.	Coil Ref.	Power		Coil Group	Dwg. No.
	1	(2)		Min	Max (MOPD)		Min	Max					AC W	DC W		
BSP	mm			bar	AC bar	DC bar	°C	°C								
1/8"	1.8	1.5	110	0	-	8	-30	80	TPE/PVDF	131K0648	2161	495294	-	9	13.0	7872
	1.8	1.5	110	0	-	8	-30	80	TPE/PVDF	131K0648	2161	496193	-	9	13.0	7872



For this page	Port size	Orifice (mm)	Qn (l/min)	MOPD (bar)	Fluid Temp (°C)
From	1/8"	1.8	110	8	-30
To	1/8"	1.8	110	8	80

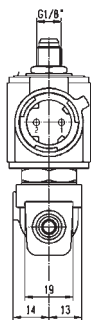
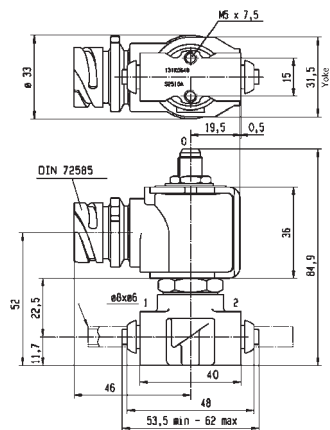

Drawing 7872

5 WAY DISTRIBUTORS FOR PNEUMATIC APPLICATIONS



5 WAY PNEUMATIC DISTRIBUTORS (PIPE MOUNTING/SUB-BASE MOUNTING)



5/2

Actuation	Body	Function	Port Size	Orifice (mm)	Qn (l/min)	MOPD (bar)	Max Fluid Temp. (°C)	Page Parker Valves
Pilot Operated	Anodized Aluminium/ Pipe Mounting	Normally Closed	1/8-1/4"	6	630	10	75	244
			1/4"	6 to 14	2500	40	75	244 and 246
			1/2"	14	2500	15	75	246
		Control by Electric Impulse	1/8-1/4"	6	630	10	75	248
			1/4"	8	1000	15	75	248
			1/2"	14	2500	15	75	248
	Anodized Aluminium/ Pipe Mounting/Poppet	Normally Closed	1/8"	4	400	10	75	250
			1/4"	8	1400	10	75	258
		Dual Solenoids	1/8"	4	315	10	75	258
			1/4"	8	1400	10	100	260
	Anodized Aluminium/ Sub-base Mounting	Normally Closed	SB	6	630	10	75	252
		Control by Electric Impulse	SB	6	630	10	75	252
	Anodized Aluminium/ Sub-base Mounting/ Poppet	Normally Closed	SB	4 to 15	5000	10	75	252
		Dual Solenoids	SB	4	400	10	75	254
Control by Electric Impulse		SB	15	5000	10	75	256	
Anodized Aluminium/ CETOP/Poppet	Dual Solenoids	SB	6	800	10	75	256	
	POM/CETOP/Poppet	Normally Closed	SB	6	800	10	75	260
Externally Operated	Anodized Aluminium/ Sub-base Mounting	Control by Electric Impulse	SB	6	800	10	75	264
		Normally Closed	SB	7	800	10	75	266

5/2

5 WAY PNEUMATIC DISTRIBUTORS (PIPE MOUNTING/SUB-BASE MOUNTING) PILOT OPERATED



Process



Industrial Equipment

ANODIZED ALUMINIUM PIPE MOUNTING

SPRING RETURN

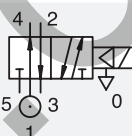
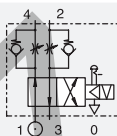

Port size	Orifice Ø	Flow factor	Operating Pressure Differential			Fluid Temp.		Seat Seal	Valve Ref.	Housing Ref.	Coil Ref.	Power		Coil Group	Dwg. No.	
			Min	Max (MOPD)	AC bar	DC bar	Min					Max	AC W			DC W
1/4"	6	630	1	10	10	-10	75	NBR	341B34 ₃	4270	481000	8	8	2.0	3286	
	6	630	1	10	10	-10	75	NBR	341B34 ₃	2995	481865	8	9	2.0	3286	
	6	630	1	10	10	-10	75	NBR	341B34 ₃	4270	486265	14	14	2.0	3286	
	6	630	1	10	10	-10	75	NBR	341B3403 ₄	4270	481000	8	8	2.1	3286	
	6	630	1	10	10	-10	75	NBR	341B3403 ₄	2995	481865	8	9	2.1	3286	
	6	560	1	-	10	-10	55	NBR	341B3490	2995	48358001	*	-	0.5-3	6.0/7.0/8.0	3561
	6	560	1	-	10	-10	75	NBR	341B3490	-	495910	*	-	0.3-1.2	6.0/7.0/8.0	3561
	6	630	1	10	10	-25	75	PUR	341B3440 ₃	4270	481000	8	8	2.1	3286	
	6	630	1	10	10	-25	75	PUR	341B3440 ₃	2995	481865	8	9	2.1	3286	
	8	640	1	40	40	-10	75	NBR	341B02 ₂	4270	481000	8	8	2.1	8115	
	8	640	1	40	40	-10	75	NBR	341B02 ₂	2995	481865	8	9	2.1	8115	

Notes:

1. Valve only compatible with air and neutral gases
2. Valve with pilot return pipe on exhaust port
3. With Flow regulator e manual override
4. With manual override

5/2

5 WAY PNEUMATIC DISTRIBUTORS (PIPE MOUNTING/SUB-BASE MOUNTING) PILOT OPERATED

ANODIZED ALUMINIUM

PIPE MOUNTING

SPRING RETURN

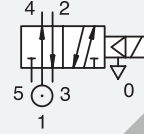

Port size	Orifice Ø	Flow factor	Operating Pressure Differential			Fluid Temp.		Seat Seal	Valve Ref.	Housing Ref.	Coil Ref.	IS	Power		Coil Group	Dwg. No.
			Min	Max (MOPD)	Max	Min	Max						AC W	DC W		
BSP	1	Qn l/min	bar	AC bar	DC bar	°C	°C									
1/4"	8	1000	1	15	15	-10	75	NBR	E341B01	2995	481865		8	9	2.1	3309
	8	1000	1	15	15	-10	75	NBR	E341B01	4270	485100		8	8	2.1	3309
	14	2500	2	15	15	-10	75	NBR	E341F21	4270	481000		8	8	2.1	3310
1/2"	14	2500	1	15	15	-10	75	NBR	E341B21	2995	481865		8	9	2.1	3315
	14	2500	1	15	15	-10	65	NBR	E341B21	-	483371		8	8	2.1	3315

Notes:

1. Valve only compatible with air and neutral gases
2. Valve with pilot return pipe on exhaust port
3. With Flow regulator e manual override
4. With manual override



For this page	Port size	Orifice (mm)	Qn (l/min)	MOPD (bar)	Fluid Temp (°C)
From	1/4"	8	1000	15	-10
To	1/2"	14	2500	15	75

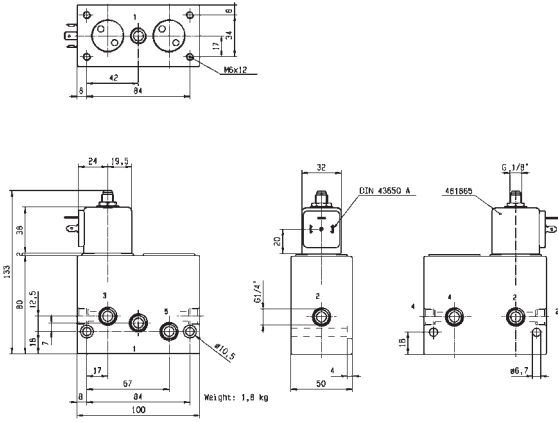

Drawing 3309

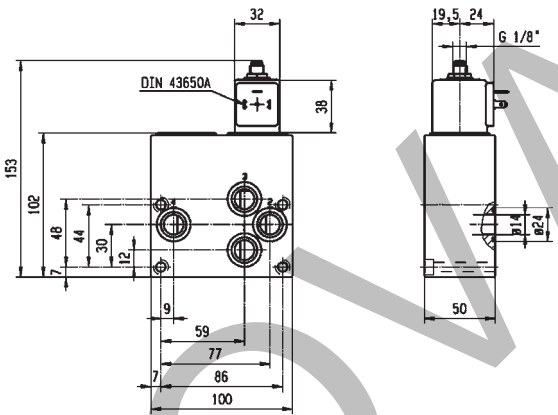

Drawing 3310

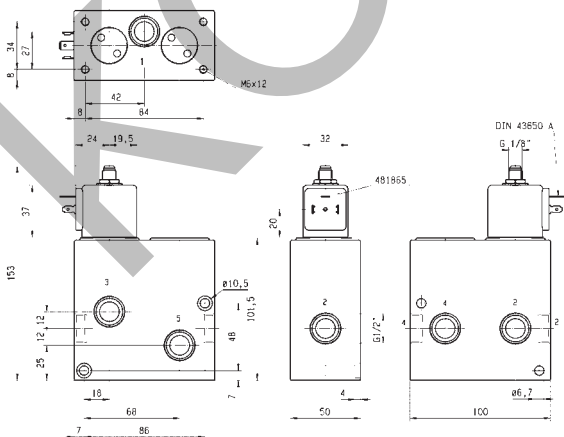

Drawing 3315

5/2

5 WAY PNEUMATIC DISTRIBUTORS (PIPE MOUNTING/SUB-BASE MOUNTING) PILOT OPERATED

ANODIZED ALUMINIUM

PIPE MOUNTING

CONTROL BY ELECTRIC IMPULSE

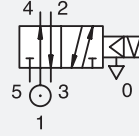

Port size	Orifice Ø	Flow factor	Operating Pressure Differential			Fluid Temp.		Seat Seal	Valve Ref.	Housing Ref.	Coil Ref.	Power		Coil Group	Dwg. No.
			Min	Max (MOPD)		Min	Max					AC W	DC W		
BSP	mm	Qn l/min	bar	AC bar	DC bar	°C	°C								
1/8-1/4"	6	630	1	10	-	-10	75	NBR	345B34 ₁₂	4269	484990	11	-	4.0	3286
	6	630	1	-	10	-10	75	NBR	345B34 ₁₂	4269	485400	-	13	4.0	3286
1/4"	8	1000	1	15	-	-10	75	NBR	345B04	4269	484990	11	-	4.0	3309
	8	1000	1	-	15	-10	75	NBR	345B04	4269	485400	-	13	4.0	3309
1/2"	14	2500	1	15	-	-10	75	NBR	345B24	4269	484990	11	-	4.0	3315
	14	2500	1	-	15	-10	75	NBR	345B24	4269	485400	-	13	4.0	3315

Notes:

- 1. Valve only compatible with air and neutral gases
- 2. With flow regulator e manual override



For this page	Port size	Orifice (mm)	Qn (l/min)	MOPD (bar)	Fluid Temp (°C)
From	1/8-1/4"	6	630	10	-10
To	1/2"	14	2500	15	75

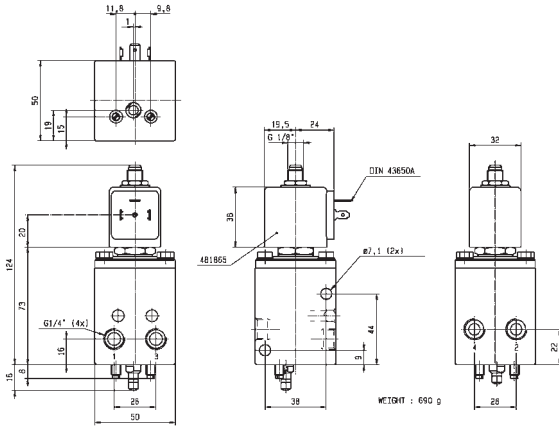

Drawing 3286

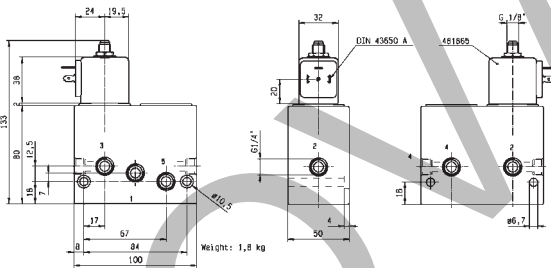
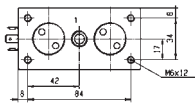

Drawing 3309

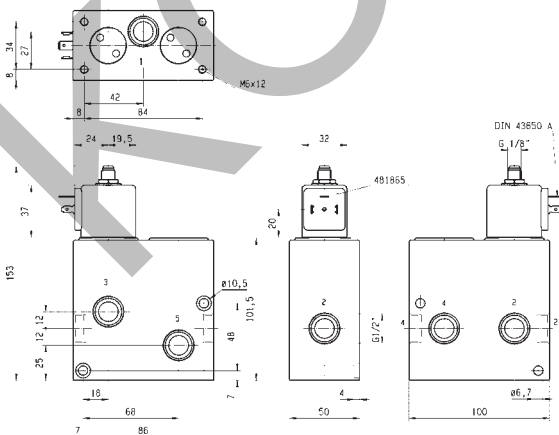

Drawing 3315

5/2

5 WAY PNEUMATIC DISTRIBUTORS (PIPE MOUNTING/SUB-BASE MOUNTING) PILOT OPERATED

ANODIZED ALUMINIUM PIPE MOUNTING

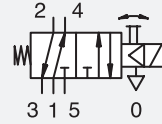

SPRING RETURN

Port size	Orifice Ø	Flow factor	Operating Pressure Differential			Fluid Temp.		Seat Seal	Valve Ref.	Housing Ref.	Coil Ref.	Power		Coil Group	Dwg. No.
			Min	Max (MOPD)	Min	Max	AC W					DC W			
BSP	mm	Qn l/min	bar	AC bar	DC bar	°C	°C								
1/8"	4	400	1	10	10	-10	65	NBR	341L9101	-	482605	4	5	1.1	3894
	4	400	1	10	10	-10	65	NBR	341L9101	-	482606	2	2.5	1.1	3894
	4	400	1	10	10	-10	75	NBR	341L9101	8993	488980	2	2.5	1.1	3894
	4	400	1	10	10	-10	50	NBR	341L9101	8993	495865	2	2.5	1.1	3894

Notes:

1. With manual override

ANODIZED ALUMINIUM PIPE MOUNTING

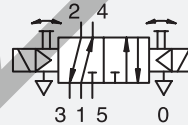

DUAL SOLENOIDS

Port size	Orifice Ø	Flow factor	Operating Pressure Differential			Fluid Temp.		Seat Seal	Valve Ref.	Housing Ref.	Coil Ref.	Power		Coil Group	Dwg. No.
			Min	Max (MOPD)	Min	Max	AC W					DC W			
BSP	mm	Qn l/min	bar	AC bar	DC bar	°C	°C								
1/8"	4	315	2	10	10	-10	65	NBR	347L9101	-	482605	4	5	1.1	3896
	4	315	2	10	10	-10	65	NBR	347L9101	-	482606	2	2.5	1.1	3896
	4	315	2	10	10	-10	75	NBR	347L9101	8993	488980	2	2.5	1.1	3896
	4	315	2	10	10	-10	50	NBR	347L9101	8993	495865	2	2.5	1.1	3896

Notes:

1. With manual override

5/2

5 WAY PNEUMATIC DISTRIBUTORS (PIPE MOUNTING/SUB-BASE MOUNTING) PILOT OPERATED

ANODIZED ALUMINIUM SUB-BASE MOUNTING

SPRING RETURN

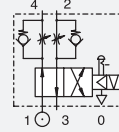

Port size	Orifice Ø 1 mm	Flow factor Qn l/min	Operating Pressure Differential		Fluid Temp.		Seat Seal	Valve Ref.	Housing Ref.	Coil Ref.	Power		Coil Group	Dwg. No.	
			Min bar	Max (MOPD) AC bar DC bar	Min °C	Max °C					AC W	DC W			
SB	6	630	1	10	10	-10	75	NBR	341F34 ₁₂	2995	481865	8	9	2.1	3287
	6	630	1	10	10	-10	75	NBR	341F34 ₁₂	4270	481000	8	8	2.1	3287
	6	630	1	10	10	-10	75	NBR	341F3403 ₂	2995	481865	8	9	2.1	3287
	6	630	1	10	10	-10	75	NBR	341F3403 ₂	4270	481000	8	8	2.1	3287
	6	630	1	10	10	-25	75	NBR	341F3440 ₁₂	2995	481865	8	9	2.1	3287

Notes:

1. With flow regulator
2. With manual override

ANODIZED ALUMINIUM SUB-BASE MOUNTING

CONTROL BY ELECTRIC IMPULSE

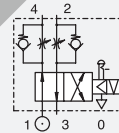

Port size	Orifice Ø 1 mm	Flow factor Qn l/min	Operating Pressure Differential		Fluid Temp.		Seat Seal	Valve Ref.	Housing Ref.	Coil Ref.	Power		Coil Group	Dwg. No.	
			Min bar	Max (MOPD) AC bar DC bar	Min °C	Max °C					AC W	DC W			
SB	6	630	1	10	-	-10	75	NBR	345F34 ₁	4269	484990	11	-	4.0	3287
	6	630	1	-	10	-10	75	NBR	345F34 ₁	4269	485400	-	13	4.0	3287

Notes:

1. With flow regulator and manual override



For this page	Port size	Orifice (mm)	Qn (l/min)	MOPD (bar)	Fluid Temp (°C)
From	SB	6	630	10	-25
To	SB	6	630	10	75

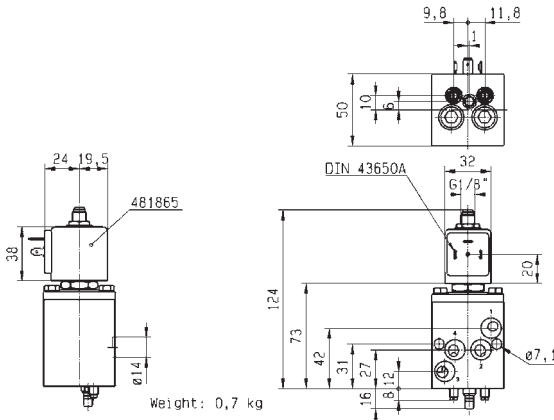

Drawing 3287

KOVARZ

5/2

5 WAY PNEUMATIC DISTRIBUTORS (PIPE MOUNTING/SUB-BASE MOUNTING) PILOT OPERATED

ANODIZED ALUMINIUM SUB-BASE MOUNTING

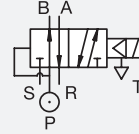

SPRING RETURN

Port size	Orifice Ø 1 mm	Flow factor Qn l/min	Operating Pressure Differential			Fluid Temp.		Seat Seal	Valve Ref.	Housing Ref.	Coil Ref.	Power		Coil Group	Dwg. No.
			Min bar	Max (MOPD)		Min °C	Max °C					AC W	DC W		
				AC bar	DC bar										
SB	15	5000	0.5	10	10	-10	75	FKM	E341L21	2995	481865	8	9	2.1/3.0	3299
	15	5000	0.5	10	10	-10	75	FKM	E341L21	-	495905	8	8	2.1/3.0	3299
SB	15	5000	0.5	-	10	-10	55	NBR	341L2190	2995	48358001	*	- 0.5-3	6.0/7.0/8.0	8271
	15	5000	0.5	-	10	-10	75	NBR	341L2190	-	495910	*	- 0.3-1.2	6.0/7.0/8.0	8271
SB	4	400	1	10	10	-10	65	NBR	341L9201	-	482605	4	5	1.1	3895
	4	400	1	10	10	-10	65	NBR	341L9201	-	482606	2	2.5	1.1	3895
	4	400	1	10	10	-10	75	NBR	341L9201	8993	488980	2	2.5	1.1	3895
	4	400	1	10	10	-10	50	NBR	341L9201	8993	495865	2	2.5	1.1	3895

ANODIZED ALUMINIUM SUB-BASE MOUNTING

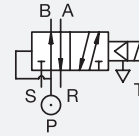

NORMALLY CLOSED

Port size	Orifice Ø 1 mm	Flow factor Qn l/min	Operating Pressure Differential			Fluid Temp.		Seat Seal	Valve Ref.	Housing Ref.	Coil Ref.	Power		Coil Group	Dwg. No.
			Min bar	Max (MOPD)		Min °C	Max °C					AC W	DC W		
				AC bar	DC bar										
SB	4	400	1	10	10	-10	75	NBR	341L9201	-	482605	-	5	1.1	3895
	4	400	1	10	10	-10	75	NBR	341L9201	-	482606	2	2.5	1.1	3895
	4	400	1	10	10	-10	75	NBR	341L9201	8993	488980	2	2.5	1.1	3895
	4	400	1	10	10	-10	75	NBR	341L9201	8993	495865	2	2.5	1.1	3895

Notes:
1. With manual override



For this page	Port size	Orifice (mm)	Qn (l/min)	MOPD (bar)	Fluid Temp (°C)
From	SB	4	400	10	-10
To	SB	15	5000	10	75

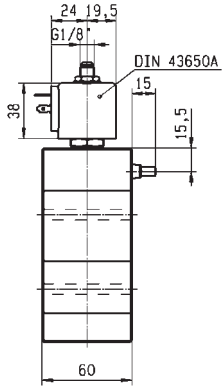

Weight : 1240 gr

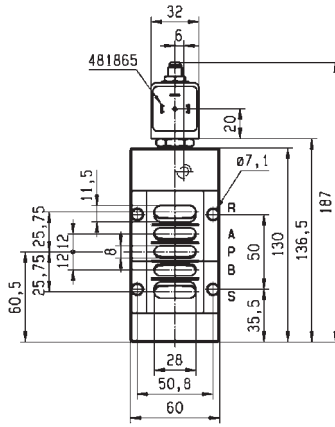

Drawing 3299

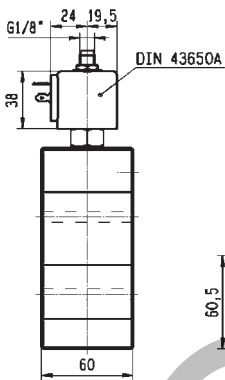

Weight : 1240 gr

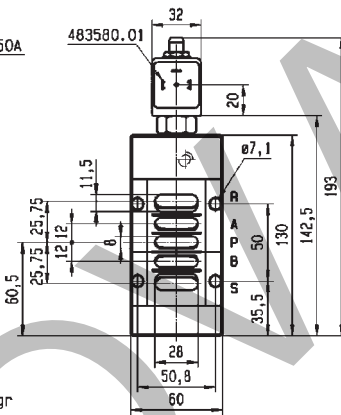

Drawing 8271

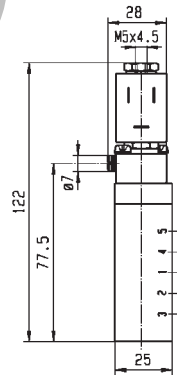
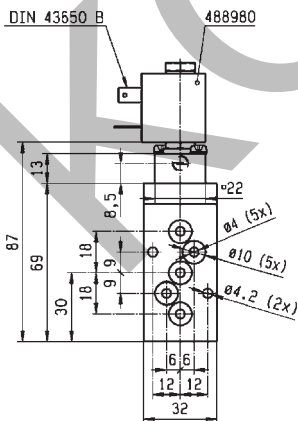

Drawing 3895

5/2

5 WAY PNEUMATIC DISTRIBUTORS (PIPE MOUNTING/SUB-BASE MOUNTING) PILOT OPERATED

ANODIZED ALUMINIUM SUB-BASE MOUNTING

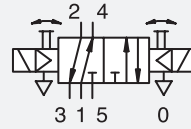

DUAL SOLENOIDS

Port size	Orifice Ø 1 mm	Flow factor Qn l/min	Operating Pressure Differential		Fluid Temp.		Seat Seal	Valve Ref.	Housing Ref.	Coil Ref.	Power		Coil Group	Dwg. No.
			Min bar	Max (MOPD) AC bar DC bar	Min °C	Max °C					AC W	DC W		
SB	4	315	2	10 10	-10	65	NBR	347L9201	-	482605	4	5	1.1	3897
	4	315	2	10 10	-10	65	NBR	347L9201	-	482606	2	2.5	1.1	3897
	4	315	2	10 10	-10	75	NBR	347L9201	8993	488980	2	2.5	1.1	3897
	4	315	2	10 10	-10	50	NBR	347L9201	8993	495865	2	2.5	1.1	3897

ANODIZED ALUMINIUM SUB-BASE MOUNTING

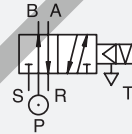

CONTROL BY ELECTRIC IMPULSE

Port size	Orifice Ø 1 mm	Flow factor Qn l/min	Operating Pressure Differential		Fluid Temp.		Seat Seal	Valve Ref.	Housing Ref.	Coil Ref.	Power		Coil Group	Dwg. No.
			Min bar	Max (MOPD) AC bar DC bar	Min °C	Max °C					AC W	DC W		
SB	15	5000	0.5	10 -	-10	75	NBR	345L21	4269	484990	11	-	4.0	3299
	15	5000	0.5	- 10	-10	75	NBR	345L21	4269	485400	-	13	4.0	3299

ANODIZED ALUMINIUM CETOP

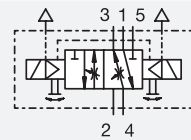

DUAL SOLENOIDS

Port size	Orifice Ø 1 mm	Flow factor Qn l/min	Operating Pressure Differential		Fluid Temp.		Seat Seal	Valve Ref.	Housing Ref.	Coil Ref.	Power		Coil Group	Dwg. No.
			Min bar	Max (MOPD) AC bar DC bar	Min °C	Max °C					AC W	DC W		
SB	6	800	1	10 10	-10	75	NBR	347L04	8993	488980	2	2.5	1.1	3694

5/2

5 WAY PNEUMATIC DISTRIBUTORS (PIPE MOUNTING/SUB-BASE MOUNTING) PILOT OPERATED

ANODIZED ALUMINIUM

PIPE MOUNTING

SPRING RETURN

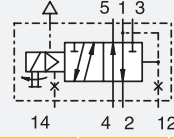

Port size	Orifice Ø	Flow factor	Operating Pressure Differential		Fluid Temp.		Seat Seal	Valve Ref.	Housing Ref.	Coil Ref.	Power		Coil Group	Dwg. No.	
			Min	Max (MOPD)	Min	Max					AC W	DC W			
BSP	mm	Qn l/min	bar	AC bar	DC bar	°C	°C								
1/4"	8	1400	1	10	10	-10	75	NBR	341L11	8993	488980	2	2.5	1.1	3434
	8	1400	1	10	10	-10	50	NBR	341L11	8993	495865	2	2.5	1.1	3434
	8	1400	1	10	10	-10	65	NBR	341L11	-	482605	4	5	1.1	3434
	8	1400	1	10	10	-10	65	NBR	341L11	-	482606	2	2.5	1.1	3434
	8	1400	1	10	10	-10	75	NBR	E341L1130	2995	481865	8	9	2.1/3.0	3539
	8	1400	1	10	10	-10	65	NBR	E341L1130	-	483371	8	8	2.1/3.0	3539
1/4" NPT	8	1400	1	10	10	-10	75	FKM	U341L1130	2995	481865	8	9	2.1	8297
	8	1400	1	10	10	-10	75	FKM	U341L1130	2995	491514	11	12	2.1	8297



For this page	Port size	Orifice (mm)	Qn (l/min)	MOPD (bar)	Fluid Temp (°C)
From	1/4"	8	1400	10	-10
To	1/4"	8	1400	10	75

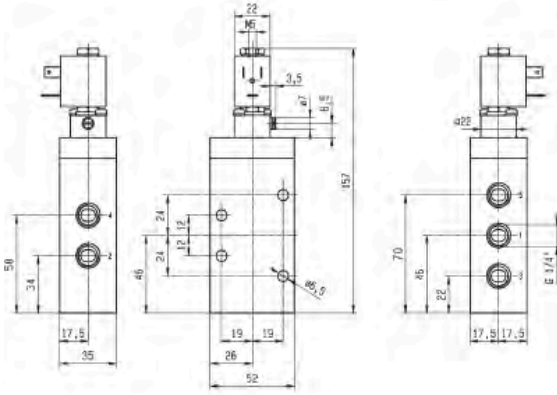

Drawing 3434

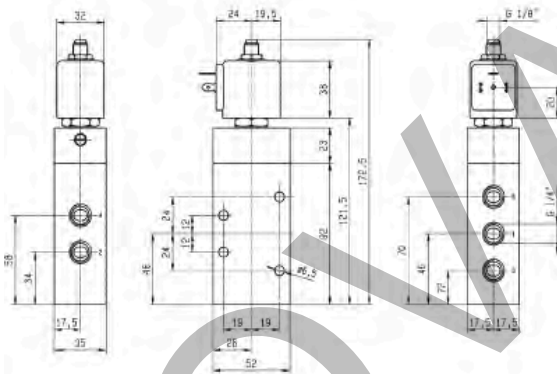

Drawing 3539

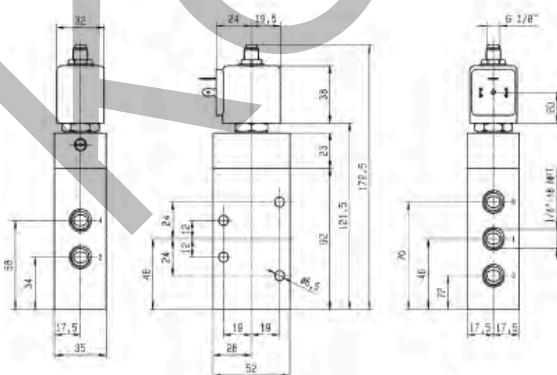

Drawing 8297

5/2

5 WAY PNEUMATIC DISTRIBUTORS (PIPE MOUNTING/SUB-BASE MOUNTING) PILOT OPERATED

ANODIZED ALUMINIUM PIPE MOUNTING

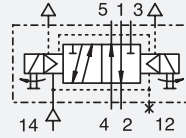

DUAL SOLENOIDS

Port size	Orifice Ø	Flow factor	Operating Pressure Differential		Fluid Temp.		Seat Seal	Valve Ref.	Housing Ref.	Coil Ref.	Power		Coil Group	Dwg. No.	
			Min	Max (MOPD)	Min	Max					AC W	DC W			
BSP	mm	Qn l/min	bar	AC bar	DC bar	°C	°C								
1/4"	8	1400	1	10	10	-10	65	NBR	347L11 ₁	-	482605	4	5	1.1	3461
	8	1400	1	10	10	-10	65	NBR	347L11 ₁	-	482606	2	2.5	1.1	3461
	8	1400	1	10	10	-10	75	NBR	347L11 ₁	8993	488980	2	2.5	1.1	3461
	8	1400	1	10	10	-10	50	NBR	347L11 ₁	8993	495865	2	2.5	1.1	3461
	8	1400	2	10	10	-10	100	FKM	E347L1130 ₁	2995	481865	8	9	2.1/3.0	3541
	8	1400	2	10	10	-10	100	FKM	E347L1130 ₁	4270	481000	8	8	2.1/3.0	3541

Notes:

1. With manual override

POM CETOP

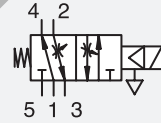

SPRING RETURN

Port size	Orifice Ø	Flow factor	Operating Pressure Differential		Fluid Temp.		Seat Seal	Valve Ref.	Housing Ref.	Coil Ref.	IS	Power		Coil Group	Dwg. No.
			Min	Max (MOPD)	Min	Max						AC W	DC W		
BSP	mm	Qn l/min	bar	AC bar	DC bar	°C	°C								
SB	6	800	1	10	10	-10	75	FKM	E341L02	2995	481865	8	9	2.1/3.0	3513
	6	800	1	10	10	-10	75	FKM	E341L02	4270	481000	8	8	2.1/3.0	3513

Notes:

1. Manual override and flow regulating screws standard

2. With manual override

IECEx certified



For this page	Port size	Orifice (mm)	Qn (l/min)	MOPD (bar)	Fluid Temp (°C)
From	1/4"	6	800	10	-10
To	1/4"	8	1400	10	100

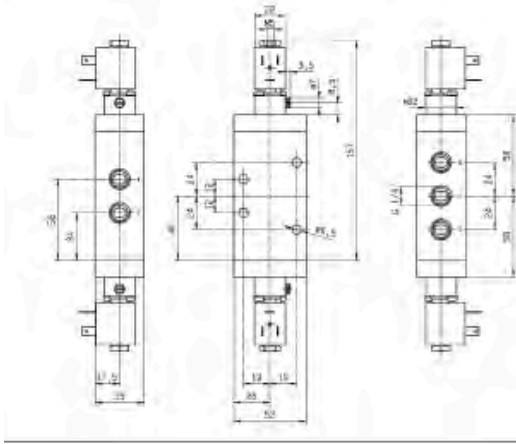

Drawing 3461

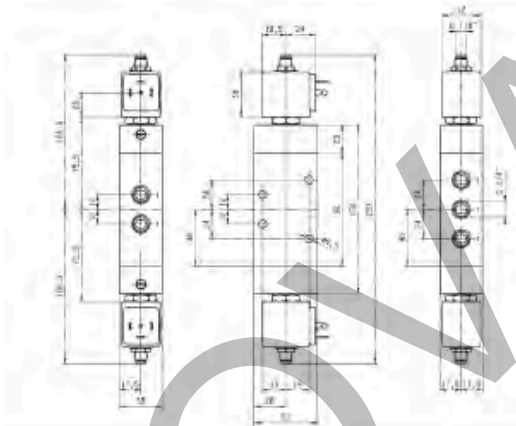

Drawing 3541

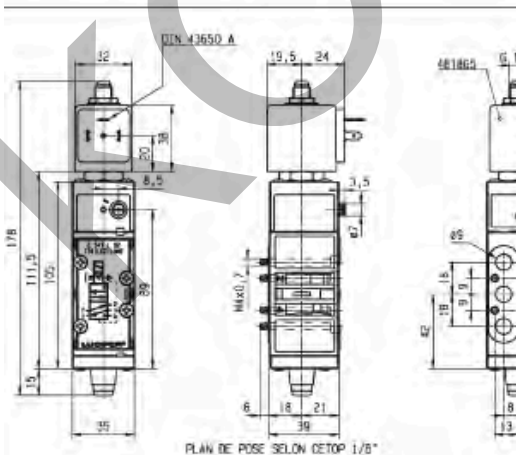

Drawing 3513

5/2

5 WAY PNEUMATIC DISTRIBUTORS (PIPE MOUNTING/SUB-BASE MOUNTING) PILOT OPERATED

POM
CETOP

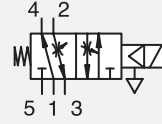

SPRING RETURN

Port size	Orifice Ø	Flow factor	Operating Pressure Differential		Fluid Temp.		Seat Seal	Valve Ref.	Housing Ref.	Coil Ref.	IS Power		Coil Group	Dwg. No.
			Min	Max (MOPD)	Min	Max					AC W	DC W		
BSP	mm	Qn l/min	bar	AC bar	DC bar	°C	°C							
SB	8	800	1	10	10	-10	65	FKM 341L04 ₁	-	482605	4	5	1.1	3437
	8	800	1	10	10	-10	65	FKM 341L04 ₁	-	482606	2	2.5	1.1	3437
	8	800	1	10	10	-10	75	FKM 341L04 ₁	8993	488980	2	2.5	1.1	3437
	8	800	1	10	10	-10	50	FKM 341L04 ₁	8993	495865	2	2.5	1.1	3437
SB	6	800	1	-	10	-10	75	NBR 341L0197	2995	482740	-	1.6	6.0/8.0	8021
	6	800	1	10	10	-10	75	NBR 341L0197	-	495900	2.5	2	6.0/8.0	8021
	6	800	1	-	10	-10	75	NBR 341L0197	-	495910	-	0.3-1.2	6.0/8.0	8021
	6	800	1	-	10	-10	65	NBR 341L0197	2995	496125	-	1.6	6.0/8.0	8021
	6	800	1	10	10	-10	65	NBR 341L05 ₂	-	482605	4	5	1.1	3430
	6	800	1	10	10	-10	65	NBR 341L05 ₂	-	482606	2	2.5	1.1	3430
	6	800	1	10	10	-10	75	NBR 341L05 ₂	8993	488980	2	2.5	1.1	3430
	6	800	1	10	10	-10	50	NBR 341L05 ₂	8993	495865	2	2.5	1.1	3430
	6	800	1	10	-	-10	75	FKM E341L01 ₁	2995	482722	10	-	2.1/3.0	3255
	6	800	1	10	10	-10	65	FKM E341L01 ₁	-	483371	8	8	2.1/3.0	3255
6	800	1	10	10	-10	75	FKM E341L01 ₁	299533	491514	11	12	2.1/3.0	3255	

Notes:

1. Manual override and flow regulating screws standard
2. With manual override

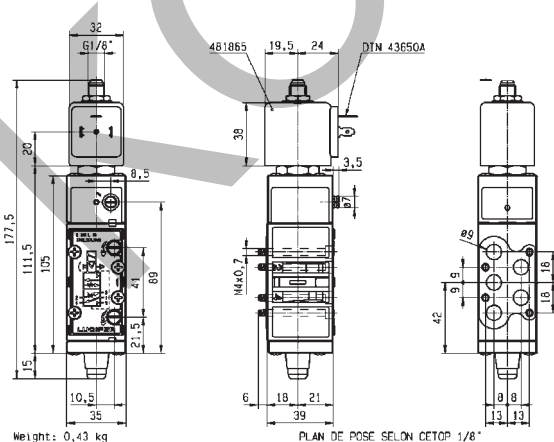

Drawing 3255

5/2

5 WAY PNEUMATIC DISTRIBUTORS (PIPE MOUNTING/SUB-BASE MOUNTING) PILOT OPERATED

POM

CETOP

CONTROL BY ELECTRIC IMPULSE

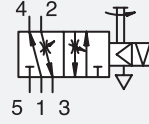

Port size	Orifice Ø	Flow factor	Operating Pressure Differential		Fluid Temp.		Seat Seal	Valve Ref.	Housing Ref.	Coil Ref.	Power		Coil Group	Dwg. No.
			Min	Max (MOPD)	Min	Max					AC W	DC W		
BSP	mm	Qn l/min	bar	AC bar	DC bar	°C	°C							
SB	6	800	1	- 10	-10 75	-10	75	FKM	345L01 ₁	4269	485400	- 13	4.0	3255

Notes:

1. Manual override and flow regulating screws standard

KONVARI



For this page	Port size	Orifice (mm)	Qn (l/min)	MOPD (bar)	Fluid Temp (°C)
From	SB	6	800	10	-10
To	SB	6	800	10	75

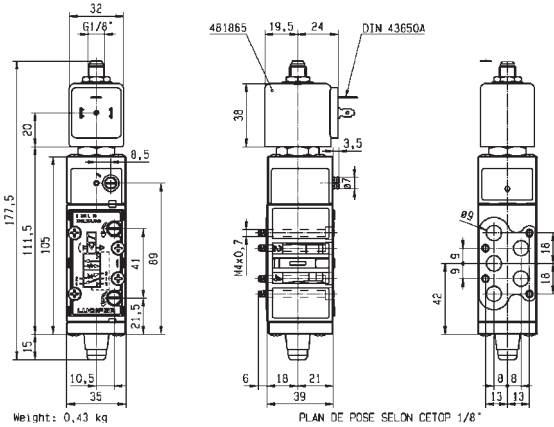

Weight: 0.43 kg



Drawing 3255

KOVAR

5/2

5 WAY PNEUMATIC DISTRIBUTORS (PIPE MOUNTING/SUB-BASE MOUNTING) EXTERNALLY OPERATED



ANODIZED ALUMINIUM SUB-BASE MOUNTING

SPRING RETURN

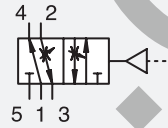

Port size	Orifice Ø 1 mm	Flow factor Qn l/min	Operating Pressure Differential		Fluid Temp.		Seat Seal FKM/ NBR	Valve Ref.	Housing Ref.	Coil Ref.	Power		Coil Group	Dwg. No.
			Min bar	Max (MOPD) AC bar	DC bar	Min °C					Max °C	AC W		
SB	7	800	1	10	10	-10	75	541L01	-	-	-	-	-	3254



For this page	Port size	Orifice (mm)	Qn (l/min)	MOPD (bar)	Fluid Temp (°C)
From	SB	7	800	10	-10
To	SB	7	800	10	75

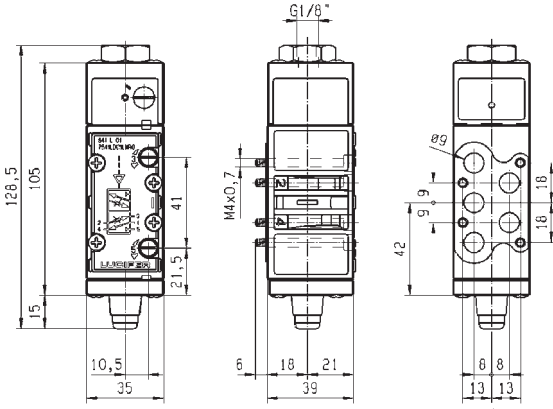

Weight: 0.36 kg

PLAN DE POSE SELON CETOP 1/8"



Drawing 3254

KOVAR



3 & 5 WAY PNEUMATIC VALVES FOR ACTUATOR CONTROL (PIPE MOUNTING)



3/2
5/2

Actuation	Body	Function	Port Size	Orifice (mm)	Qn (l/min)	MOPD (bar)	Max Fluid Temp. (°C)	Page Parker Valves	
Direct Operated	Brass/Pipe mounting	Normally Closed	1/8"	1.2 to 1.5	70	10	75	276	
			1/8"-1/4"	2.5	220	7	75	276	
			1/4"	1	36	10	120	276	
		Normally Open/Universal	1/4"	2.5 - 6	680	7-10	75	282	
	Control by Electric Impulse		1/4"	2.5	220	7	100	284	
			Brass/Sub-base mounting	Normally Closed	5 mm	2.5	180	2	75
	Universal	1/8"		2	140	7	120	286	
Pilot Operated	Anodized aluminium/ Pipe mounting	Universal	1/4"	6	680	10	75	288	
	Anodized aluminium/ Pipe mounting/Spool	Normally Closed	1/8"	4 to 15	600	10	80	290	
			1/4"	7 to 8	1400	10	80	292	
			1/2"	12	3000	10	50	296	
		Dual Solenoids	1/8"	4	400	10	80	298	
			1/4"	7 to 8	1400	10	80	300	
			1/2"	12	3000	10	50	302	
	Control by Electric Impulse	1/8"	4	600	10	80	302		
		Manual Reset	Brass/Pipe mounting	Universal	1/4"	6	680	10	65

3/2

3 & 5 WAY PNEUMATIC VALVES FOR ACTUATOR CONTROL (PIPE MOUNTING) DIRECT OPERATED

BRASS

PIPE MOUNTING

NORMALLY CLOSED

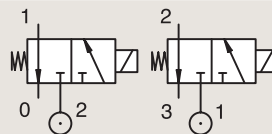

Port size	Orifice Ø	Flow factor	Operating Pressure Differential			Fluid Temp.		Seat Seal	Valve Ref.	Housing Ref.	Coil Ref.	ATEX Zone	Protection Mode	Power		Coil Group	Dwg. No.
			Min	Max (MOPD)	Max	Min	Max							AC W	DC W		
BSP	1	Qn l/min	bar	AC bar	DC bar	°C	°C										
1/8"	1.2	50	0	10	10	-10	75	FKM	131M15	8993	488980	-	-	2	2.5	1.1	3382
	1.2	50	0	10	10	-10	75	FKM	131M1550	8993	488980	-	-	2	2.5	1.1	3382
	1.5	70	0	7	7	-10	75	FKM	131M14	8993	488980	-	-	2	2.5	1.1	3382
1/8"-1/4"	2.5	220	0	7	7	-40	75	PUR	E131K0358	2995	481865	-	-	8	9	2.1	3510
	2.5	220	0	7	7	-40	75	PUR	E131K0358	4270	481000	-	-	8	8	2.1	3510
1/4"	1	36	0	-	10	-10	55	FKM	131K0490	2995	483580.01	0-20	Ex ia IIC T6	-	0.5 to 3	7.0	7058
	1	36	0	-	10	-10	75	FKM	131K0490	-	488660.01	0-20	Ex ia IIC T6	-	0.3 to 3	7.0	7058
	1	36	0	-	10	-10	75	FKM	131K0490	-	495910	0-20	Ex ia IIC T4 to T6	-	0.3 to 3	7.0	7058

Notes:

1. With manual override



For this page	Port size	Orifice (mm)	Qn (l/min)	MOPD (bar)	Fluid Temp (°C)
From	1/8"	1	36	7	-40
To	1/4"	2.5	220	10	75

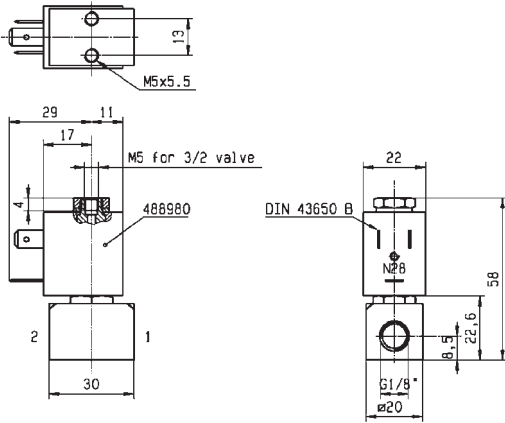

Drawing 3382

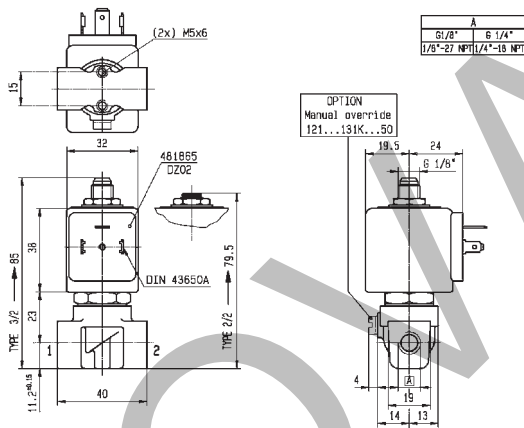

Drawing 3510

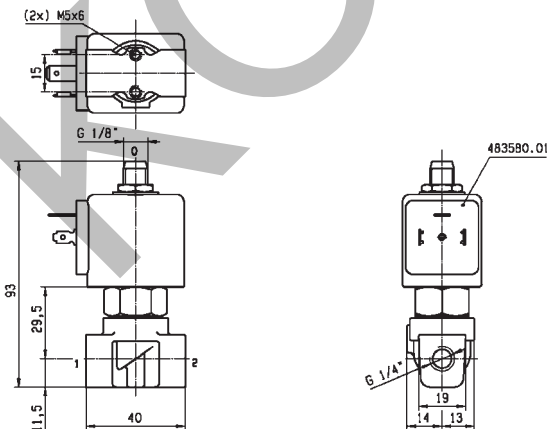

Drawing 7058

3/2

3 & 5 WAY PNEUMATIC VALVES FOR ACTUATOR CONTROL (PIPE MOUNTING) DIRECT OPERATED

BRASS

PIPE MOUNTING

NORMALLY CLOSED

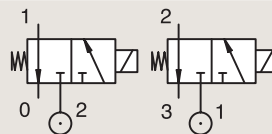

Port size	Orifice Ø	Flow factor	Operating Pressure Differential			Fluid Temp.		Seat Seal	Valve Ref.	Housing Ref.	Coil Ref.	ATEX Zone	Protection Mode	Power		Coil Group	Dwg. No.
			Min	Max (MOPD)	DC bar	Min	Max							AC W	DC W		
1/4"	1.5	80	0	-	7	-20	75	PUR	131K0497	2995	482740	-	-	-	1.6	6.0/8.0	8023
	1.5	80	0	7	7	-20	75	PUR	131K0497	-	495900	1-21	Ex d mb IIC T4 to T6	2.5	2	6.0/8.0	8023
	1.5	80	0	-	7	-20	75	PUR	131K0497	-	495910	0-20	Ex ia IIC T4 to T6	-	0.3 to 3	6.0/8.0	8023
	1.5	80	0	-	7	-20	75	PUR	131K0497	2995	496125	2-22	Ex nAC IIC T5/T6	-	1.6	6.0/8.0	8023
	1.5	80	0	16	16	-10	100	FKM	E131K04	2995	481865	-	-	8	9	2.0	3510
	1.5	80	0	16	16	-10	120	FKM	E131K04	4270	481000	-	-	8	8	2.0	3510
	1.5	80	0	16	16	-10	120	FKM	E131K04	4270	486265	-	-	14	14	2.0	3510
	1.5	80	0	15	15	-10	100	FKM	E131K0450 ₁	2995	481865	-	-	8	9	2.1	3510
	1.5	80	0	15	15	-10	120	FKM	E131K0450 ₁	4270	481000	-	-	8	8	2.1	3510
	2	140	0	10	10	-10	100	FKM	E131K06	2995	481865	-	-	8	9	2.0	8119
	2	140	0	10	10	-10	120	FKM	E131K06	4270	481000	-	-	8	8	2.0	8119
	2	140	0	10	10	-10	120	FKM	E131K06	4270	486265	-	-	14	14	2.0	8119
	2	140	0	10	10	-10	100	FKM	E131K0650 ₁	2995	481865	-	-	8	9	2.1	3510
	2	140	0	10	10	-10	120	FKM	E131K0650 ₁	4270	481000	-	-	8	8	2.1	3510

Notes:

1. With manual override



For this page	Port size	Orifice (mm)	Qn (l/min)	MOPD (bar)	Fluid Temp (°C)
From	1/4"	1.5	80	7	-20
To	1/4"	2	140	16	120

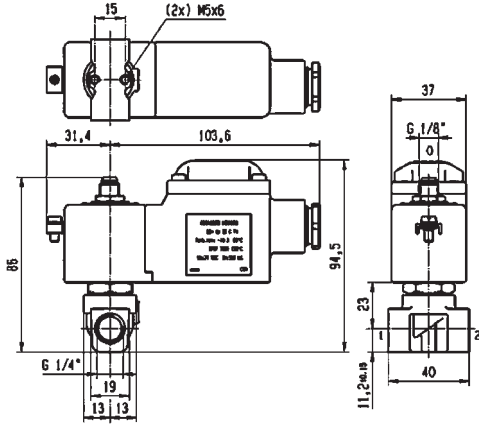

Drawing 8023

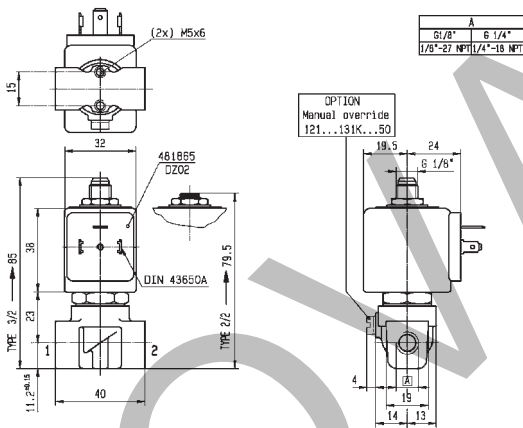

Drawing 3510

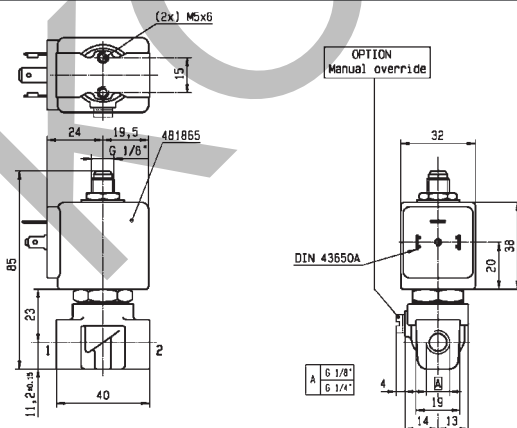

Drawing 8119

3/2

3 & 5 WAY PNEUMATIC VALVES FOR ACTUATOR CONTROL (PIPE MOUNTING) DIRECT OPERATED

BRASS

PIPE MOUNTING

NORMALLY CLOSED

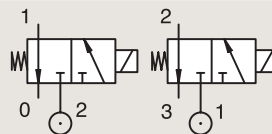

Port size	Orifice Ø	Flow factor	Operating Pressure Differential			Fluid Temp.		Seat Seal	Valve Ref.	Housing Ref.	Coil Ref.	ATEX Zone	Protection Mode	Power		Coil Group	Dwg. No.
			Min	Max (MOPD)	DC bar	Min	Max							AC W	DC W		
1/4"	2.5	220	0.1	7	7	-10	75	FKM	E131E03	2995	481865	-	-	8	9	2.0	3525
	2.5	220	0.1	7	7	-10	75	FKM	E131E03	4270	481000	-	-	8	8	2.0	3525
	2.5	220	0.1	7	7	-10	75	FKM	E131E03	4270	486265	-	-	14	14	2.0	3525
	2.5	220	0	7	7	-40	75	PUR	E131K0308	2995	481865	-	-	8	9	2.1	3510
	2.5	220	0	7	7	-40	75	PUR	E131K0308	4270	481000	-	-	8	8	2.1	3510
	2.5	220	0	7	7	-10	100	FKM	E131K0350 ₁	2995	481865	-	-	8	9	2.1	3510
	2.5	220	0	7	7	-10	120	FKM	E131K0350 ₁	4270	481000	-	-	8	8	2.1	3510
	4.5	500	0	2	2	-10	75	FKM	131T2101 ₁	2995	481865	-	-	8	9	2.1	3223
	4.5	500	0	2	2	-10	75	FKM	131T2101 ₁	4270	481000	-	-	8	8	2.1	3223

Notes:

1. With manual override

3 & 5 WAY PNEUMATIC DISTRIBUTORS



For this page	Port size	Orifice (mm)	Qn (l/min)	MOPD (bar)	Fluid Temp (°C)
From	1/4"	2.5	220	2	-40
To	1/4"	4.5	500	7	120

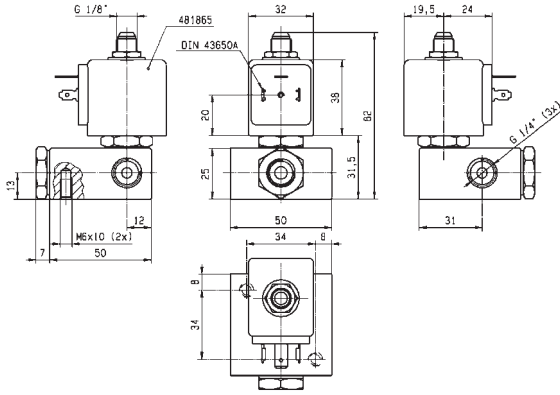

Drawing 3525

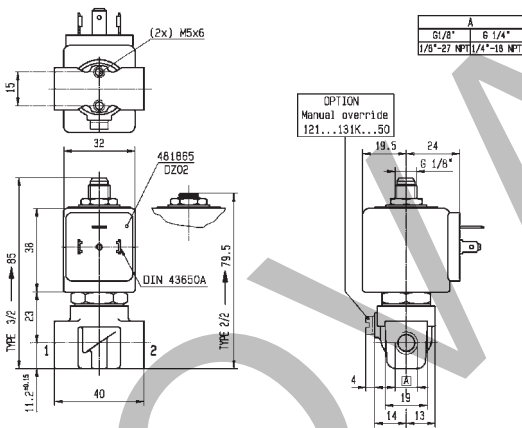

Drawing 3510

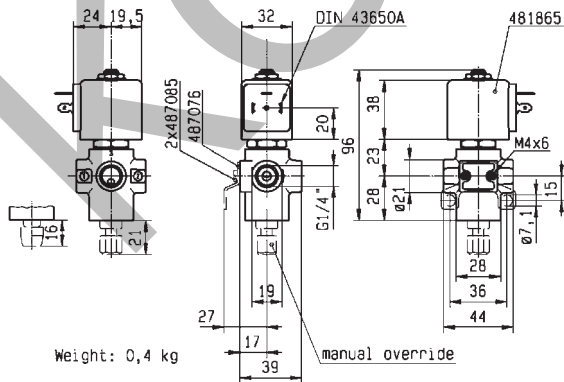

Weight: 0,4 kg

manual override



Drawing 3223

3/2

3 & 5 WAY PNEUMATIC VALVES FOR ACTUATOR CONTROL (PIPE MOUNTING) DIRECT OPERATED

BRASS

PIPE MOUNTING

NORMALLY OPEN

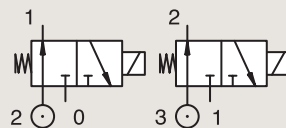

Port size	Orifice Ø	Flow factor	Operating Pressure Differential		Fluid Temp.		Seat Seal	Valve Ref.	Housing Ref.	Coil Ref.	ATEX Zone	Protection Mode	Power		Coil Group	Dwg. No.	
			Min	Max (MOPD)	Min	Max							AC W	DC W			
BSP	1	Qn l/min	bar	AC bar	DC bar	°C	°C										
	2.5	220	0	7	3.5	-10	75	FKM	132T29	2995	481865	-	-	8	9	2.0	3223
1/4"	2.5	220	0	7	3.5	-10	75	FKM	132T29	4270	481000	-	-	8	8	2.0	3223
	2.5	220	0	-	7	-10	75	FKM	132T29	4270	486265	-	-	-	14	2.0	3223

BRASS

PIPE MOUNTING

UNIVERSAL

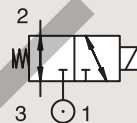

Port size	Orifice Ø	Flow factor	Operating Pressure Differential		Fluid Temp.		Seat Seal	Valve Ref.	Housing Ref.	Coil Ref.	ATEX Zone	Protection Mode	Power		Coil Group	Dwg. No.	
			Min	Max (MOPD)	Min	Max							AC W	DC W			
BSP	1	Qn l/min	bar	AC bar	DC bar	°C	°C										
1/4"	6	680	0	12	12	-25	65	NBR	U133X0111	-	492310	1-21	Ex e mb II T3 to T6	6	6	9.0/10.1/10.2	7422
NPT	6	680	0	-	12	-25	75	NBR	U133X0111	-	492965.01	0-20	Ex ia IIC T6	-	0.3 to 3	9.0/10.1/10.2	7422

Notes:

1.DC voltage only. Minimum drop off voltage is 15% of nominal voltage (former DIN 19251)

3/2

3 & 5 WAY PNEUMATIC VALVES FOR ACTUATOR CONTROL (PIPE MOUNTING) DIRECT OPERATED

BRASS

PIPE MOUNTING

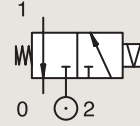

CONTROL BY ELECTRIC IMPULSE

Port size	Orifice Ø 1	Flow factor Qn l/min	Operating Pressure Differential			Fluid Temp.		Seat Seal	Valve Ref.	Housing Ref.	Coil Ref.	ATEX Zone	Protection Mode	Power		Coil Group	Dwg. No.
			Min	Max (MOPD)	Max	Min	Max							AC W	DC W		
BSP	mm		bar	AC bar	DC bar	°C	°C										
1/4"	2.5	220	0	-	7	-10	100	FKM	135K03	4269	485400	-	-	-	13	4.0	3510

KONVANT



For this page	Port size	Orifice (mm)	Qn (l/min)	MOPD (bar)	Fluid Temp (°C)
From	1/4"	2.5	220	7	-25
To	1/4"	2.5	220	7	100

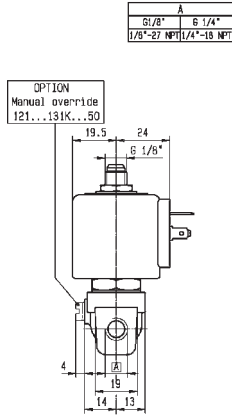
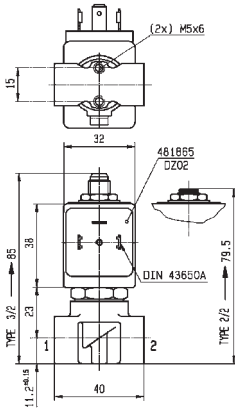

Drawing 3510

KOOLVAN.COM

3/2

3 & 5 WAY PNEUMATIC VALVES FOR ACTUATOR CONTROL (PIPE MOUNTING) DIRECT OPERATED

BRASS

SUB-BASE MOUNTING

NORMALLY CLOSED

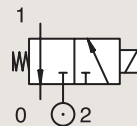

Port size	Orifice Ø 1 mm	Flow factor Qn l/min	Operating Pressure Differential			Fluid Temp.		Seat Seal	Valve Ref.	Housing Ref.	Coil Ref.	ATEX Zone	Protection Mode	Power		Coil Group	Dwg. No.
			Min	Max (MOPD) AC bar DC bar	Min	Max	°C							°C	AC W		
SB	2.5	180	0	-	2	-20	75	PUR	131F4397	2995	482740	-	-	-	1.6	6.0/8.0	8022
	2.5	180	0	2	2	-20	75	PUR	131F4397	-	495900	1-21	Ex d mb IIC T4 to T6	2.5	2	6.0/8.0	8022
	2.5	180	0	-	2	-20	75	PUR	131F4397	-	495910	0-20	Ex ia IIC T4 to T6	-	0.3 to 3	6.0/8.0	8022
	2.5	180	0	-	2	-20	75	PUR	131F4397	2995	496125	2-22	Ex nAC IIC T5/T6	-	1.6	6.0/8.0	8022

BRASS

SUB-BASE MOUNTING

UNIVERSAL

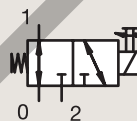

Port size	Orifice Ø 1 mm	Flow factor Qn l/min	Operating Pressure Differential			Fluid Temp.		Seat Seal	Valve Ref.	Housing Ref.	Coil Ref.	ATEX Zone	Protection Mode	Power		Coil Group	Dwg. No.
			Min	Max (MOPD) AC bar DC bar	Min	Max	°C							°C	AC W		
SB	2	140	0	7	7	-10	100	FKM	133F4650 ₁	2995	481865	-	-	8	9	2.1	3509
	2	140	0	7	7	-10	120	FKM	133F4650 ₁	4270	481000	-	-	8	8	2.1	3509

Notes:

1. With manual override



For this page	Port size	Orifice (mm)	Qn (l/min)	MOPD (bar)	Fluid Temp (°C)
From	1/8"	2	140	2	-20
To	5 mm	2.5	180	7	120

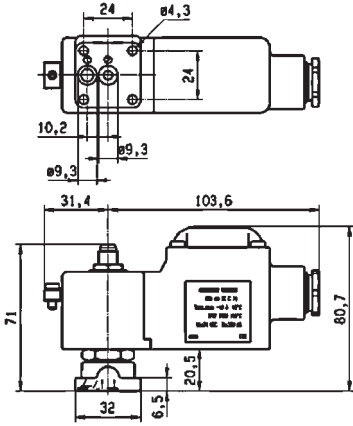

Drawing 8022

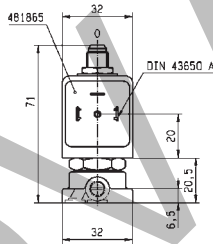
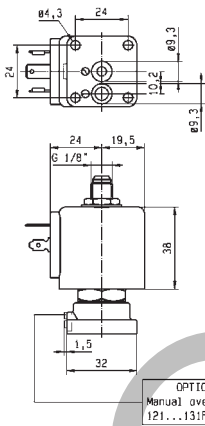

OPTION
Manual override
121...131F...50

Drawing 3509

3/2

3 & 5 WAY PNEUMATIC VALVES FOR ACTUATOR CONTROL (PIPE MOUNTING) DIRECT OPERATED

ANODIZED ALUMINIUM

PIPE MOUNTING

UNIVERSAL

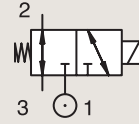

Port size	Orifice Ø 1	Flow factor Qn l/min	Operating Pressure Differential		Fluid Temp.		Seat Seal	Valve Ref.	Housing Ref.	Coil Ref.	ATEX Zone	Protection Mode	Power		Coil Group	Dwg. No.	
			Min	Max (MOPD) DC bar	Min	Max							AC W	DC W			
1/4"	6	680	0	12	12	-25	75	NBR	133X01	-	492310	1-21	Ex e mb II T3 to T6	6	6	9.0/10.1/10.2	6960
	6	680	0	12	12	-25	65	NBR	133X01	-	492965.01	0-20	Ex ia IIC T6	-	0.3 to 3	9.0/10.1/10.2	6960
	6	680	0	12	12	-25	65	NBR	133X01	-	496700	1-21	Ex d mb IIC T4 to T6	6	6	9.0/10.1/10.2	6960
	6	680	0	12	12	-25	65	NBR	133X01	-	496895	-	-	8	8	9.0/10.1/10.2	6960
1/4" NPT	6	680	0	12	12	-25	65	NBR	U133X01	-	496700	1-21	Ex d mb IIC T4 to T6	6	6	9.0/10.1/10.2	7422

KONVAV



For this page	Port size	Orifice (mm)	Qn (l/min)	MOPD (bar)	Fluid Temp (°C)
From	1/4"	6	680	10	-25
To	1/4"	6	680	10	75

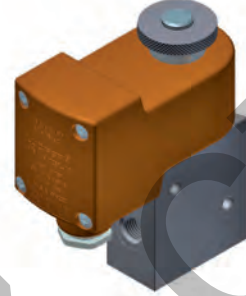
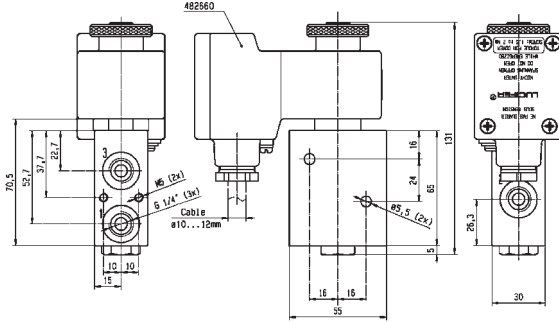

Drawing 6960

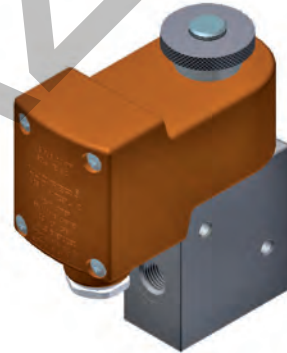
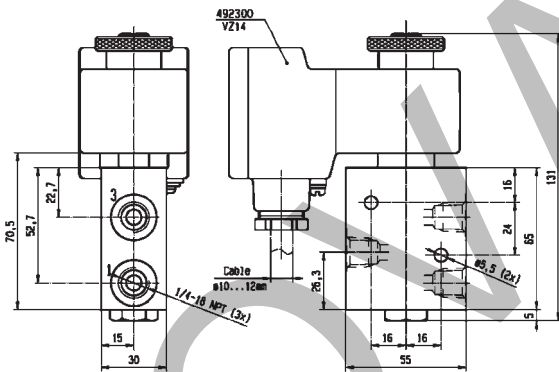

Drawing 7422

5/2

3 & 5 WAY PNEUMATIC VALVES FOR ACTUATOR CONTROL (PIPE MOUNTING) PILOT OPERATED

ANODIZED ALUMINIUM PIPE MOUNTING

NORMALLY CLOSED

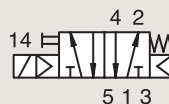

Port size	Orifice Ø	Flow factor	Operating Pressure Differential			Fluid Temp.		Seat Seal	Valve Ref.	Housing Ref.	Coil Ref.	ATEX Zone	Protection Mode	Power		Coil Group	Dwg. No.
			Min	Max (MOPD)	AC bar	DC bar	Min							Max	AC W		
1/8"	4	600	2	10	10	-25	50	NBR	341P01 ₂	-	482606	1-21	Ex mb IIC T4/T5	2	2.5	1.1	7302
	4	600	2	10	10	-25	80	NBR	341P01 ₂	8993	488980	-	-	2	2.5	1.1	7302
	4	600	2	10	10	-25	80	NBR	341P21 ₁₂	2995	481865	-	-	8	9	2.1	7296
	4	600	2	10	10	-25	80	NBR	341P21 ₁₂	4270	481000	-	-	8	8	2.1	7296
	4	600	2	10	10	-40	65	PUR	341P2108 ₂	2995	481865	-	-	8	9	2.1	7296
	4	600	2	10	10	-40	65	PUR	341P2108 ₂	4270	481000	-	-	8	8	2.1	7296
	4	600	2	-	10	-20	65	NBR/PUR	341P2197 ₂	2995	482740	-	-	-	1.6	6.0/8.0	8027
	4	600	2	10	10	-20	65	NBR/PUR	341P2197 ₂	-	495900	1-21	Ex d mb IIC T4 to T6	2.5	2	6.0/8.0	8027
	4	600	2	-	10	-20	65	NBR/PUR	341P2197 ₂	-	495910	0-20	Ex ia IIC T4 to T6	-	0.3 to 3	6.0/8.0	8027
	4	600	2	-	10	-20	65	NBR/PUR	341P2197 ₂	2995	496125	2-22	Ex nAC IIC T5/T6	-	1.6	6.0/8.0	8027
	4	600	2	-	10	-20	55	NBR/PUR	341P2197 ₂₃	2995	483580.01	0-20	Ex ia IIC T6	-	0.5 to 3	6.0/7.0/8.0	8027

Notes:

1. Pilot seat in FKM
2. With manual override
3. A minimum current of 65 mA is required with this coil configuration



For this page	Port size	Orifice (mm)	Qn (l/min)	MOPD (bar)	Fluid Temp (°C)
From	1/8"	4	600	10	-40
To	1/8"	4	600	10	80

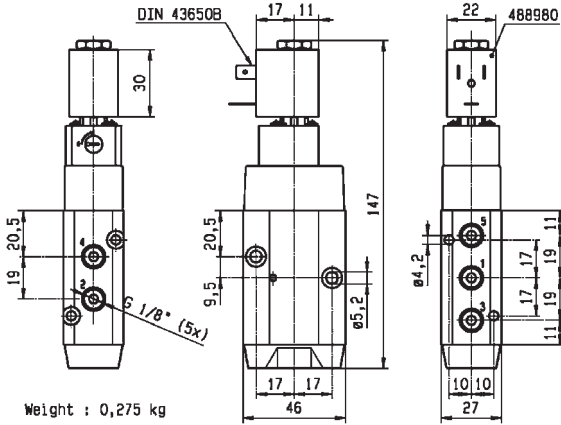

Drawing 7302

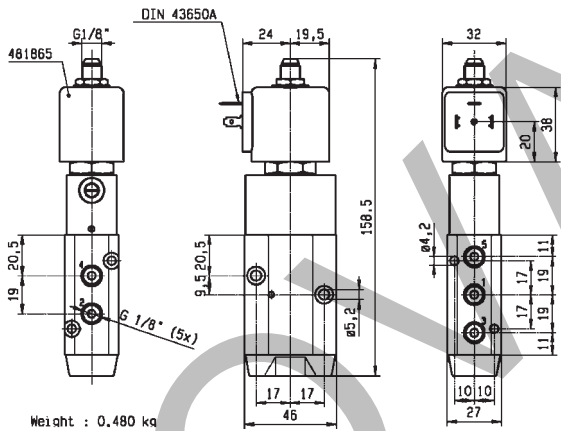

Drawing 7296

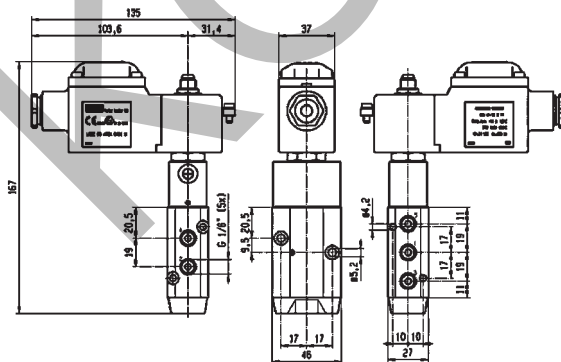

Drawing 8027

5/2

3 & 5 WAY PNEUMATIC VALVES FOR ACTUATOR CONTROL (PIPE MOUNTING) PILOT OPERATED

ANODIZED ALUMINIUM PIPE MOUNTING

NORMALLY CLOSED

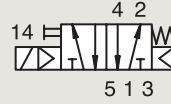

Port size	Orifice Ø	Flow factor	Operating Pressure Differential			Fluid Temp.		Seat Seal	Valve Ref.	Housing Ref.	Coil Ref.	ATEX Zone	Protection Mode	Power		Coil Group	Dwg. No.
			Min	Max (MOPD)	Min	Max	AC W							DC W			
BSP	1	Qn l/min	bar	AC bar	DC bar	°C	°C										
1/8"	15	600	2	-	10	-10	55	NBR	341P2190	2995	483580.01	0-20	Ex ia IIC T6	-	0.5 to 3	7.0	7351
	15	600	2	-	10	-10	75	NBR	341P2190	-	488660.01	0-20	Ex ia IIC T6	-	0.3 to 3	7.0	7351
	15	600	2	-	10	-10	75	NBR	341P2190	-	495910	0-20	Ex ia IIC T4 to T6	-	0.3 to 3	7.0	7351

Notes:

1. Pilot seat in FKM
2. With manual override
3. A minimum current of 65 mA is required with this coil configuration

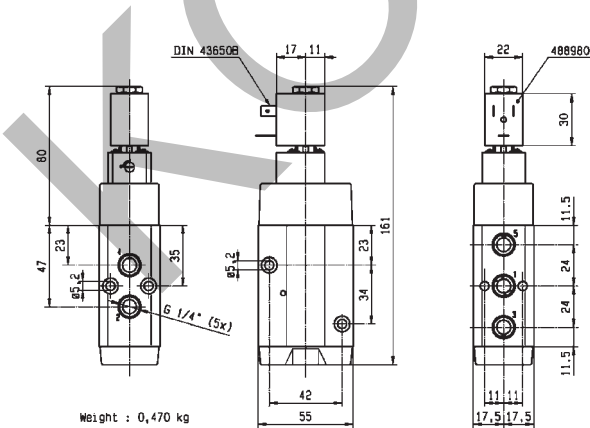

Weight : 0,470 kg



Drawing 7314



For this page	Port size	Orifice (mm)	Qn (l/min)	MOPD (bar)	Fluid Temp (°C)
From	1/8"	7	600	10	-25
To	1/4"	15	1400	10	80

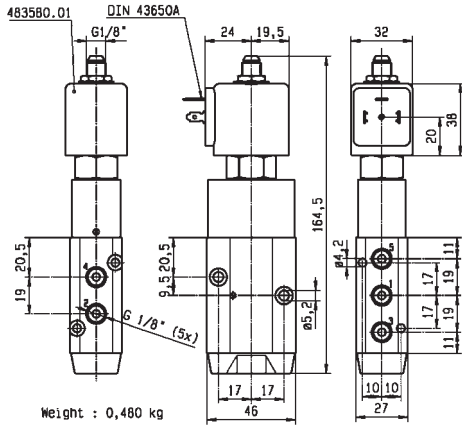

Drawing 7351

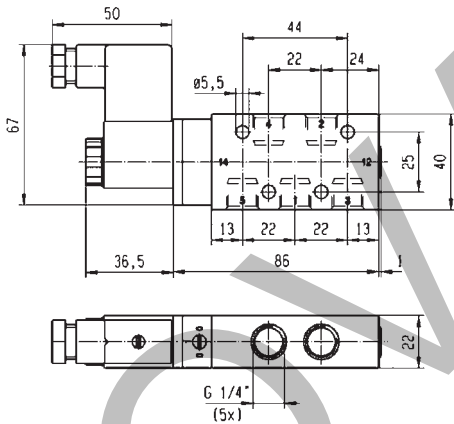

Drawing 8218

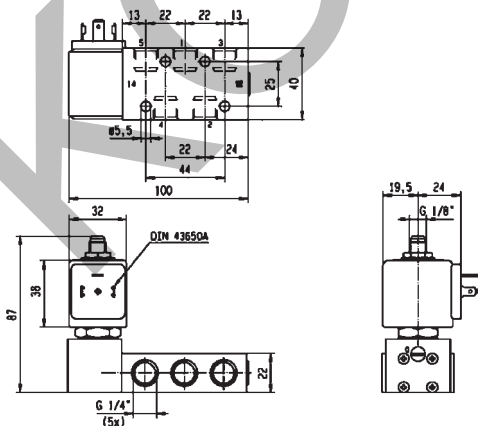

Drawing 8219



5/2

3 & 5 WAY PNEUMATIC VALVES FOR ACTUATOR CONTROL (PIPE MOUNTING) PILOT OPERATED

ANODIZED ALUMINIUM PIPE MOUNTING

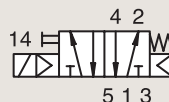

NORMALLY CLOSED

Port size	Orifice Ø	Flow factor	Operating Pressure Differential			Fluid Temp.		Seat Seal	Valve Ref.	Housing Ref.	Coil Ref.	ATEX Zone	Protection Mode	Power		Coil Group	Dwg. No.
			Min	Max (MOPD)	DC bar	Min	Max							AC W	DC W		
BSP	1	Qn l/min	bar	AC bar	DC bar	°C	°C										
1/4"	7	1250	2.5	10	10	-10	50	NBR	341P03 ₂	-	496131	-	-	3	3	1.2	8218
	7	1250	2.5	10	10	-10	50	NBR	341P03 ₂	-	496482	-	-	3	3	1.2	8218
	7	1250	2.5	10	10	-10	50	NBR	341P03 ₂	-	496637	22	Ex tD A22 IP65 - T95°C	3	3	1.2	8218
	7	1250	2.5	10	10	-20	50	NBR	341P33 ₂	2995	481865	-	-	8	9	2.1	8219
	7	1250	2.5	10	10	-20	50	NBR	341P33 ₂	-	495870	2-22	Ex nAC IIC T3/T4	8	9	2.1	8219
	7	1250	2.5	10	10	-20	50	NBR	341P33 ₂	-	495905	1-21	Ex d mb IIC T4	8	8	2.1	8219
	8	1400	2	10	10	-25	80	NBR	341P02 ₂	-	482606	1-21	Ex mb IIC T4/T5	2	2.5	1.1	7314
	8	1400	2	10	10	-25	80	NBR	341P02 ₂	8993	488980	-	-	2	2.5	1.1	7314

Notes:

1. Pilot seat in FKM
2. With manual override
3. A minimum current of 65 mA is required with this coil configuration

3 & 5 WAY PNEUMATIC DISTRIBUTORS



For this page	Port size	Orifice (mm)	Qn (l/min)	MOPD (bar)	Fluid Temp (°C)
From	1/4"	8	1400	10	-25
To	1/4"	8	1400	10	80

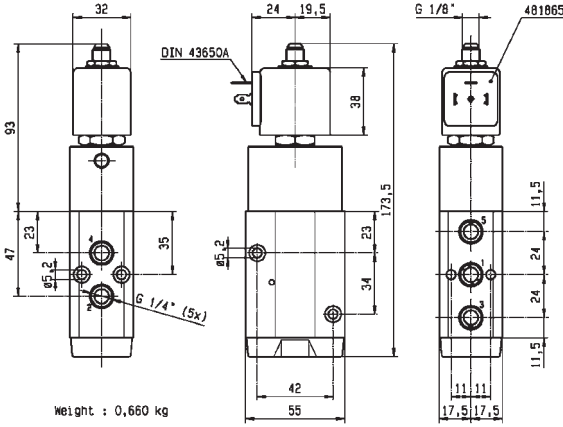

Drawing 7319

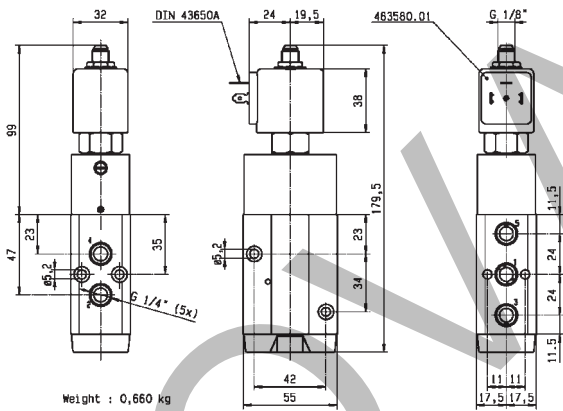

Drawing 7352

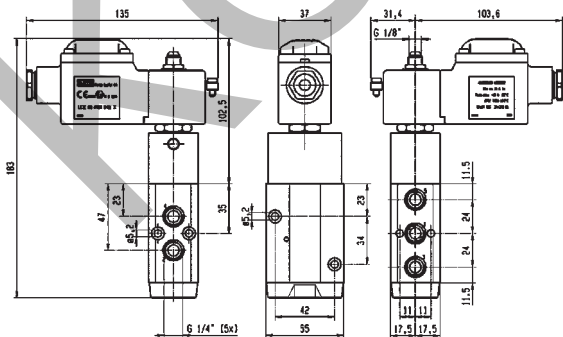

Drawing 8030

5/2

3 & 5 WAY PNEUMATIC VALVES FOR ACTUATOR CONTROL (PIPE MOUNTING) PILOT OPERATED

ANODIZED ALUMINIUM PIPE MOUNTING

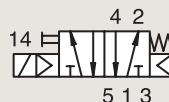

NORMALLY CLOSED

Port size	Orifice Ø	Flow factor	Operating Pressure Differential			Fluid Temp.		Seat Seal	Valve Ref.	Housing Ref.	Coil Ref.	ATEX Zone	Protection Mode	Power		Coil Group	Dwg. No.
			Min	Max (MOPD)	DC bar	Min	Max							AC W	DC W		
BSP	1	Qn l/min	bar	AC bar	DC bar	°C	°C										
1/4"	8	1400	2	10	10	-25	80	NBR	341P22 ₂	2995	481865	-	-	8	9	2.1	7319
	8	1400	2	10	10	-25	80	NBR	341P22 ₂	4270	481000	-	-	8	8	2.1	7319
	8	1400	2	-	10	-25	55	NBR	341P2290	2995	483580.01	0-20	Ex ia IIC T6	-	0.5 to 3	7.0	7352
	8	1400	2	-	10	-25	75	NBR	341P2290	-	488660.01	0-20	Ex ia IIC T6	-	0.3 to 3	7.0	7352
	8	1400	2	-	10	-25	75	NBR	341P2290	-	495910	0-20	Ex ia IIC T4 to T6	-	0.3 to 3	7.0	7352
	8	1400	2	-	10	-20	80	NBR/PUR	341P2297 ₂	2995	482740	-	-	-	1.6	6.0/8.0	8030
	8	1400	2	10	10	-20	80	NBR/PUR	341P2297 ₂	-	495900	1-21	Ex d mb IIC T4 to T6	2.5	2	6.0/8.0	8030
	8	1400	2	-	10	-20	80	NBR/PUR	341P2297 ₂	-	495910	0-20	Ex ia IIC T4 to T6	-	0.3 to 3	6.0/8.0	8030
	8	1400	2	-	10	-20	80	NBR/PUR	341P2297 ₂	2995	496125	2-22	Ex nAC IIC T5/T6	-	1.6	6.0/8.0	8030
1/2"	8	1400	2	-	10	-20	55	NBR/PUR	341P2297 ₂₃	2995	483580.01	0-20	Ex ia IIC T6	-	0.5 to 3	6.0/7.0/8.0	8030
	12	3000	2.5	10	10	-10	50	NBR	341P04 ₂	-	496131	-	-	3	3	1.2	8220
	12	3000	2.5	10	10	-10	50	NBR	341P04 ₂	-	496482	-	-	3	3	1.2	8220
	12	3000	2.5	10	10	-10	50	NBR	341P04 ₂	-	496637	22	Ex tD A22 IP65 - T95°C	3	3	1.2	8220
	12	3000	2.5	10	10	-10	50	NBR	341P34 ₂	2995	481865	-	-	8	9	2.1	8221
	12	3000	2.5	10	10	-10	50	NBR	341P34 ₂	2995	495870	2-22	Ex nAC IIC T3/T4	8	9	2.1	8221
	12	3000	2.5	10	10	-10	50	NBR	341P34 ₂	-	495905	1-21	Ex d mb IIC T4	8	8	2.1	8221

Notes:

1. Pilot seat in FKM
2. With manual override
3. A minimum current of 65 mA is required with this coil configuration



For this page	Port size	Orifice (mm)	Qn (l/min)	MOPD (bar)	Fluid Temp (°C)
From	1/2"	12	3000	10	-10
To	1/2"	12	3000	10	50

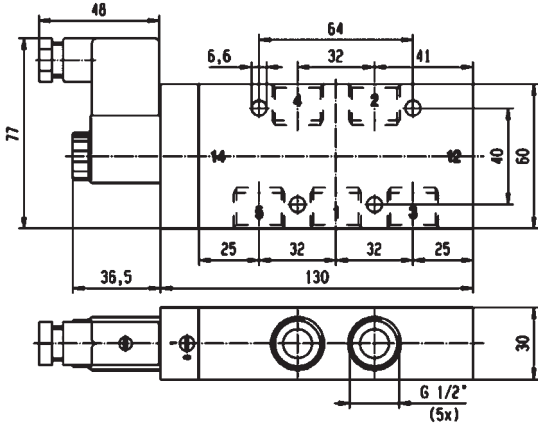

Drawing 8220

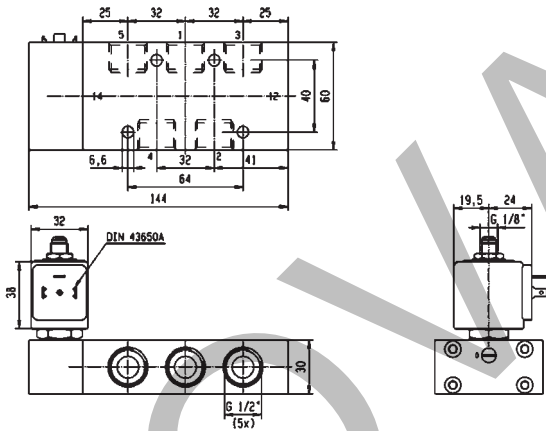

Drawing 8221

5/2

3 & 5 WAY PNEUMATIC VALVES FOR ACTUATOR CONTROL (PIPE MOUNTING) PILOT OPERATED

ANODIZED ALUMINIUM PIPE MOUNTING

DUAL SOLENOIDS

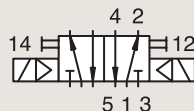

Port size	Orifice Ø	Flow factor	Operating Pressure Differential			Fluid Temp.		Seat Seal	Valve Ref.	Housing Ref.	Coil Ref.	ATEX Zone	Protection Mode	Power		Coil Group	Dwg. No.
			Min	Max	Min	Max	AC W							DC W			
BSP	mm	Qn l/min	bar	Max (MOPD) AC bar	DC bar	°C	°C										
1/8"	4	400	2	10	10	-25	80	NBR	347P01 ₂	-	482606	1-21	Ex mb IIC T4/T5	2	2.5	1.1	7306
	4	400	2	10	10	-25	80	NBR	347P01 ₂	8993	488980	-	-	2	2.5	1.1	7306
	4	400	2	10	10	-25	80	NBR	347P21 ₁₂	2995	481865	-	-	8	9	2.1	7298
	4	400	2	10	10	-25	80	NBR	347P21 ₁₂	4270	481000	-	-	8	8	2.1	7298
	4	400	2	-	10	-25	55	NBR	347P2190	2995	483580.01	0-20	Ex ia IIC T6	-	0.5 to 3	7.0	7353
	4	400	2	-	10	-25	75	NBR	347P2190	-	488660.01	0-20	Ex ia IIC T6	-	0.3 to 3	7.0	7353
	4	400	2	-	10	-25	75	NBR	347P2190	-	495910	0-20	Ex ia IIC T4 to T6	-	0.3 to 3	7.0	7353
	4	400	2	-	10	-20	65	NBR/PUR	347P2197 ₂	2995	482740	-	-	-	1.6	6.0/8.0	8028
	4	400	2	10	10	-20	65	NBR/PUR	347P2197 ₂	-	495900	1-21	Ex d mb IIC T4 to T6	2.5	2	6.0/8.0	8028
	4	400	2	-	10	-20	65	NBR/PUR	347P2197 ₂	-	495910	0-20	Ex ia IIC T4 to T6	-	0.3 to 3	6.0/8.0	8028
	4	400	2	-	10	-20	65	NBR/PUR	347P2197 ₂	2995	496125	2-22	Ex nAC IIC T5/T6	-	1.6	6.0/8.0	8028
	4	400	2	-	10	-20	55	NBR/PUR	347P2197 ₂₃	2995	483580.01	0-20	Ex ia IIC T6	-	0.5 to 3	6.0/7.0/8.0	8028

Notes:

1. Pilot seat in FKM
2. With manual override
3. A minimum current of 65 mA is required with this coil configuration

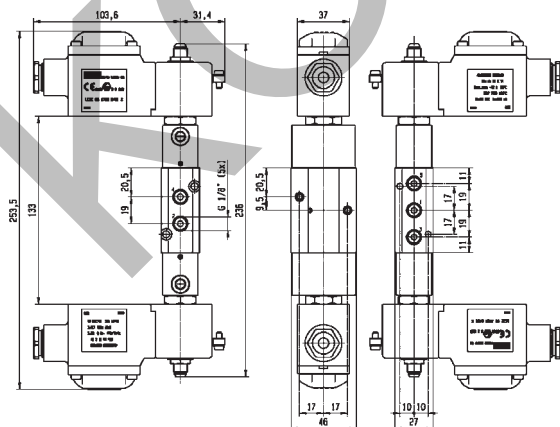

Drawing 8028



For this page	Port size	Orifice (mm)	Qn (l/min)	MOPD (bar)	Fluid Temp (°C)
From	1/8"	4	400	10	-25
To	1/8"	4	400	10	80

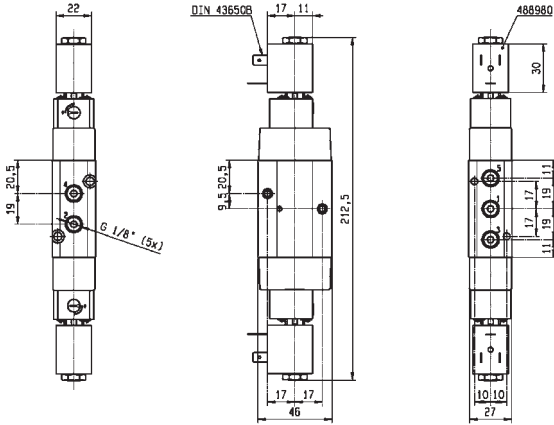

Drawing 7306

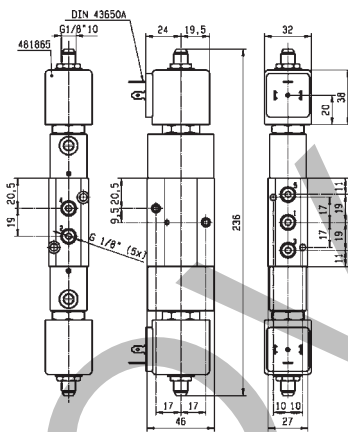

Drawing 7298

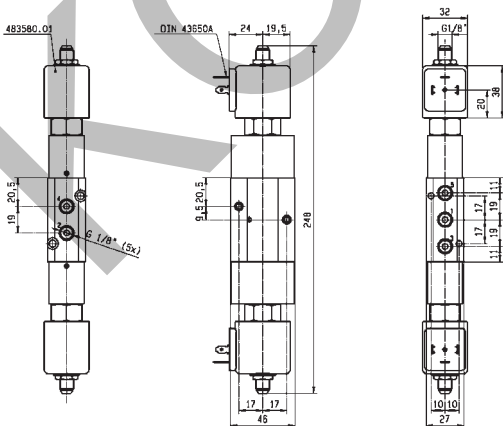

Drawing 7353

5/2

3 & 5 WAY PNEUMATIC VALVES FOR ACTUATOR CONTROL (PIPE MOUNTING) PILOT OPERATED

ANODIZED ALUMINIUM PIPE MOUNTING

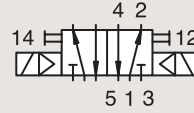

DUAL SOLENOIDS

Port size	Orifice Ø	Flow factor	Operating Pressure Differential			Fluid Temp.		Seat Seal	Valve Ref.	Housing Ref.	Coil Ref.	ATEX Zone	Protection Mode	Power		Coil Group	Dwg. No.
			Min	Max	Max (MOPD)	Min	Max							AC W	DC W		
BSP	mm	Qn l/min	bar	bar	bar	°C	°C										
1/4"	7	1250	2.5	10	10	-10	50	NBR	347P03 ₂	-	496131	-	-	3	3	1.2	8222
	7	1250	2.5	10	10	-10	50	NBR	347P03 ₂	-	496482	-	-	3	3	1.2	8222
	7	1250	2.5	10	10	-10	50	NBR	347P03 ₂	-	496637	22	Ex tD A22 IP65 - T95°C	3	3	1.2	8222
	7	1250	2.5	10	10	-10	50	NBR	347P33 ₂	2995	481865	-	-	8	9	2.1	8223
	7	1250	2.5	10	10	-10	50	NBR	347P33 ₂	2995	495870	2-22	Ex nAC IIC T3/T4	8	9	2.1	8223
	7	1250	2.5	10	10	-10	50	NBR	347P33 ₂	-	495905	1-21	Ex d mb IIC T4	8	8	2.1	8223
	8	1400	2	10	10	-25	80	NBR	347P02 ₂	-	482606	1-21	Ex mb IIC T4/T5	2	2.5	1.1	7316
	8	1400	2	10	10	-25	80	NBR	347P02 ₂	8993	488980	-	-	2	2.5	1.1	7316
	8	1400	2	10	10	-25	80	NBR	347P22 ₂	2995	481865	-	-	8	9	2.1	7321
	8	1400	2	10	10	-25	80	NBR	347P22 ₂	4270	481000	-	-	8	8	2.1	7321

Notes:

1. Pilot seat in FKM
2. With manual override
3. A minimum current of 65 mA is required with this coil configuration

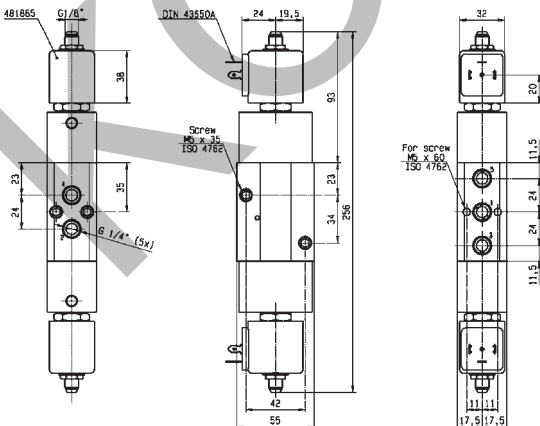

Drawing 7321



For this page	Port size	Orifice (mm)	Qn (l/min)	MOPD (bar)	Fluid Temp (°C)
From	1/4"	7	1250	10	-25
To	1/4"	8	1400	10	80

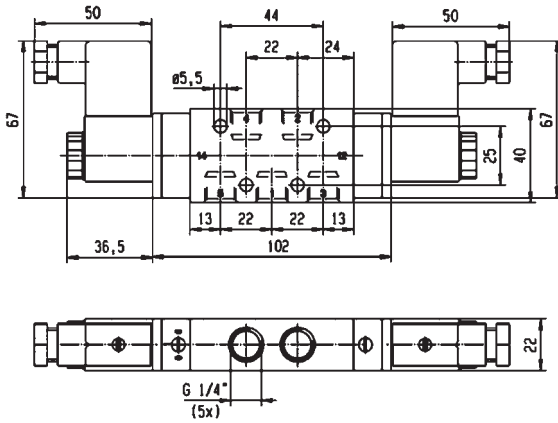

Drawing 8222

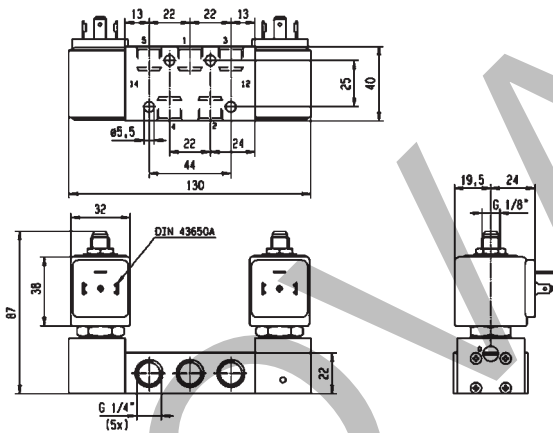

Drawing 8223

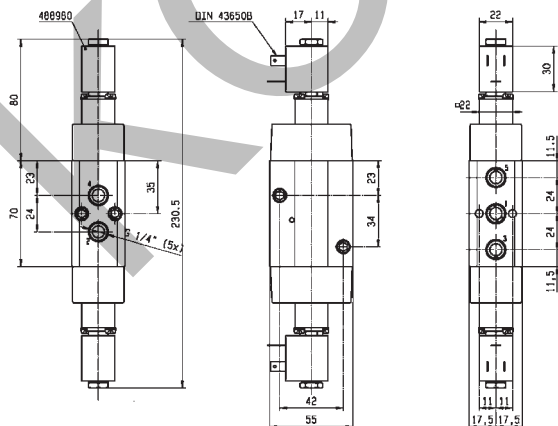

Drawing 7316

5/2

3 & 5 WAY PNEUMATIC VALVES FOR ACTUATOR CONTROL (PIPE MOUNTING) PILOT OPERATED

ANODIZED ALUMINIUM

PIPE MOUNTING

DUAL SOLENOIDS

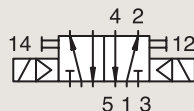

Port size	Orifice Ø	Flow factor	Operating Pressure Differential			Fluid Temp.		Seat Seal	Valve Ref.	Housing Ref.	Coil Ref.	ATEX Zone	Protection Mode	Power		Coil Group	Dwg. No.
			Min	Max (MOPD)		Min	Max							AC W	DC W		
BSP	mm	Qn l/min	bar	AC bar	DC bar	°C	°C										
1/2"	12	3000	2.5	10	10	-10	50	NBR	347P04 ₂	-	496131	-	-	3	3	1.2	8224
	12	3000	2.5	10	10	-10	50	NBR	347P04 ₂	-	496482	-	-	3	3	1.2	8224
	12	3000	2.5	10	10	-10	50	NBR	347P04 ₂	-	496637	22	Ex tD A22 IP65 - T95°C	3	3	1.2	8224
	12	3000	2.5	10	10	-10	50	NBR	347P34 ₂	2995	481865	-	-	8	9	2.1	8225
	12	3000	2.5	10	10	-10	50	NBR	347P34 ₂	2995	495870	2-22	Ex nAC IIC T3/T4	8	9	2.1	8225
	12	3000	2.5	10	10	-10	50	NBR	347P34 ₂	-	495905	1-21	Ex d mb IIC T4	8	8	2.1	8225

Notes:

1. Pilot seat in FKM
2. With manual override
3. A minimum current of 65 mA is required with this coil configuration

ANODIZED ALUMINIUM

PIPE MOUNTING

CONTROL BY ELECTRIC IMPULSE

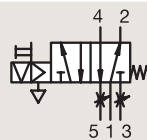

Port size	Orifice Ø	Flow factor	Operating Pressure Differential			Fluid Temp.		Seat Seal	Valve Ref.	Housing Ref.	Coil Ref.	ATEX Zone	Protection Mode	Power		Coil Group	Dwg. No.
			Min	Max (MOPD)		Min	Max							AC W	DC W		
BSP	mm	Qn l/min	bar	AC bar	DC bar	°C	°C										
1/8"	4	600	2	-	10	-25	80	NBR	345P21	4269	485400	-	-	-	13	4.0	8123

3 & 5 WAY PNEUMATIC DISTRIBUTORS



For this page	Port size	Orifice (mm)	Qn (l/min)	MOPD (bar)	Fluid Temp (°C)
From	1/8"	4	600	10	-25
To	1/2"	12	3000	10	80

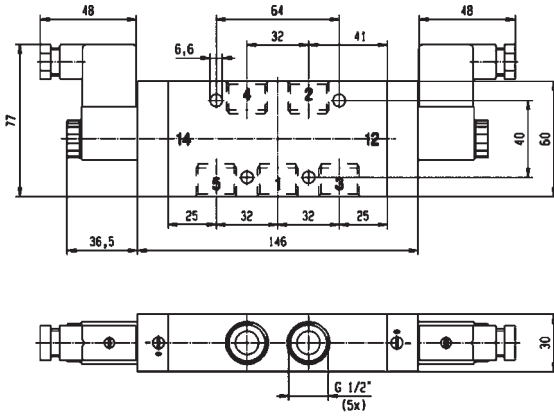

Drawing 8224

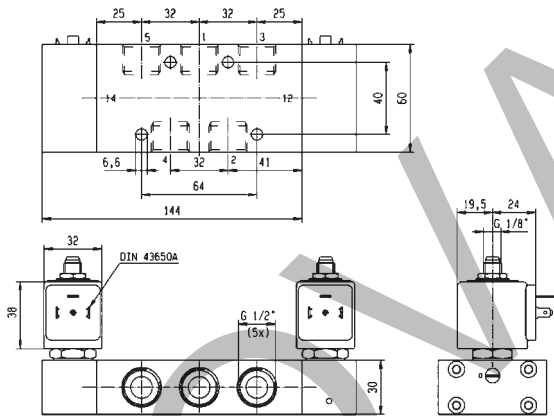

Drawing 8225

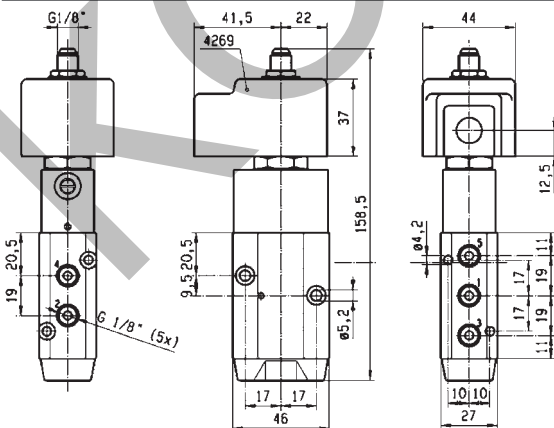

Drawing 8123

3/2

3 & 5 WAY PNEUMATIC VALVES FOR ACTUATOR CONTROL (PIPE MOUNTING) MANUAL RESET

BRASS

PIPE MOUNTING

UNIVERSAL

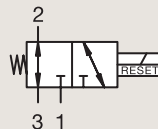

Port size	Orifice Ø 1	Flow factor Qn l/min	Operating Pressure Differential		Fluid Temp.		Seat Seal	Valve Ref.	Housing Ref.	Coil Ref.	ATEX Zone	Protection Mode	Power		Coil Group	Dwg. No.	
			Min	Max (MOPD)	Min	Max							AC W	DC W			
BSP	mm		bar	AC bar	DC bar	°C	°C										
1/4"	6	680	0	12	12	-25	65	NBR	U033X0111	-	492310	1-21	Ex e mb II T3 to T6	6	6	10.1/10.2/12.0	7641
NPT	6	680	0	12	12	-25	65	NBR	U033X0111	-	496700	1-21	Ex d mb IIC T4 to T6	6	6	10.1/10.2/12.0	7641

KONVARI



For this page	Port size	Orifice (mm)	Qn (l/min)	MOPD (bar)	Fluid Temp (°C)
From	1/4"	6	680	10	-25
To	1/4"	6	680	10	65

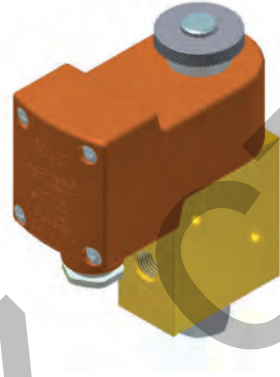
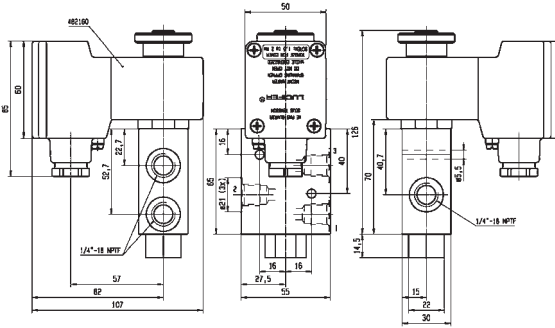

Drawing 7641

KOVAR



3 & 5 WAY PNEUMATIC VALVES FOR ACTUATOR CONTROL (NAMUR)



Air

3/2
5/2
5/3

Actuation	Body	Function	Port Size	Orifice (mm)	Qn (l/min)	MOPD (bar)	Max Fluid Temp. (°C)	Page		
Direct Operated	Anodized aluminium/ NAMUR	Normally Closed	1/4"	6	680	10	75	302		
Pilot Operated	Anodized aluminium/ NAMUR/Spool	Solenoid operated - spring return	1/8"-1/4"	4 to 8	1400	10	80	308		
			1/4"	7 to 8	1400	10	80	304		
			1/2"	12	3000	10	50	304		
		Dual Solenoids	1/8"-1/4"	4	400	10	80	320		
			1/4"	7 to 8	1400	10	120	322		
			1/2"	12	3000	10	120	324		
		W1 closed center position	1/8"-1/4"	4	400	10	80	326		
			1/4"	4 to 7	1250	10	120	326		
		W3 exhausted in center position	1/4"	7	1250	10	50	328		
		Control by Electric Impulse	1/8"-1/4"	4	600	10	80	330		
		Air Operated	Anodized aluminium/ NAMUR/Poppet	Solenoid operated - spring return	1/8"-1/4"	4	355	10	75	330
			Anodized aluminium/ NAMUR	Air operated - spring return	1/8"-1/4"	4	600	10	80	336
1/4"	7	1250	10		50	336				
1/2"	12	3000	10		50	336				
Air Operated	Anodized aluminium/ NAMUR	Air operated and return	1/4"	7	1250	10	50	336		
		W1 closed center position	1/4"	7	1250	10	50	340		

3/2

3 & 5 WAY PNEUMATIC VALVES FOR ACTUATOR CONTROL (NAMUR) DIRECT OPERATED

ANODIZED ALUMINIUM

NAMUR

NORMALLY CLOSED

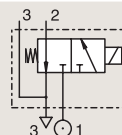

Port size	Orifice Ø	Flow factor	Operating Pressure Differential			Fluid Temp.		Seat Seal	Valve Ref.	Housing Ref.	Coil Ref.	ATEX Zone	Protection Mode	Power		Coil Group	Dwg. No.
			Min	Max (MOPD)	DC bar	Min	Max							AC W	DC W		
BSP	1	Qn l/min	bar	AC bar	DC bar	°C	°C										
1/4"	6	680	0	12	12	-25	75	NBR	131X1101	-	492310	1-21	Ex e mb II T3 to T6	6	6	9.0/10.1	7336
	6	680	0	12	12	-25	75	NBR	131X1101	-	492965.01	0-20	Ex ia IIC T6	-	0.3 to 3	9.0/10.1	7336
	6	680	0	12	12	-25	75	NBR	131X1101	-	496700	1-21	Ex d mb IIC T4 to T6	6	6	9.0/10.1	7336
	6	680	0	12	12	-25	75	NBR	131X1101	-	496895	-	-	8	8	9.0/10.1	7336
	6	680	0	12	12	-25	65	NBR	131X1131	-	492310	1-21	Ex e mb II T3 to T6	-	6	10.1/10.2	7336
	6	680	0	12	12	-25	65	NBR	131X1131	-	496700	1-21	Ex d mb IIC T4 to T6	-	6	10.1/10.2	7336
1/4" NPT	6	680	0	12	12	-25	75	NBR	U131X1101	-	492965.01	0-20	Ex ia IIC T6	-	0.3 to 3	10.1/10.2	7336
	6	680	0	12	12	-25	65	NBR	U131X1101	-	496700	1-21	Ex d mb IIC T4 to T6	6	6	10.1/10.2	7336
	6	680	0	12	12	-25	65	NBR	U131X1101	-	496895	-	-	8	8	10.1/10.2	7336

Notes:

1.DC voltage only. Minimum drop off voltage is 15% of nominal voltage (former DIN 19251)

IECEX
certified



For this page	Port size	Orifice (mm)	Qn (l/min)	MOPD (bar)	Fluid Temp (°C)
From	1/4"	6	680	10	-25
To	1/4"	6	680	10	75

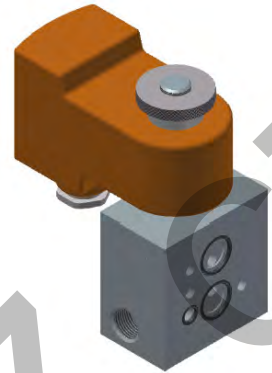
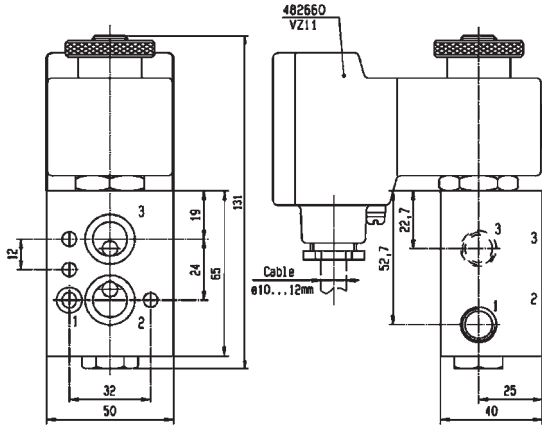

Drawing 7336

KOLVAN

3/2

3 & 5 WAY PNEUMATIC VALVES FOR ACTUATOR CONTROL (NAMUR) PILOT OPERATED

ANODIZED ALUMINIUM

NAMUR

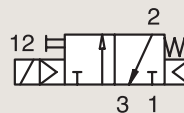

SOLENOID OPERATED - SPRING RETURN

Port size	Orifice Ø 1	Flow factor Qn l/min	Operating Pressure Differential			Fluid Temp.		Seat Seal	Valve Ref.	Housing Ref.	Coil Ref.	ATEX Zone	Protection Mode	Power		Coil Group	Dwg. No.
			Min	Max (MOPD)	DC	Min	Max							AC W	DC W		
1/4"	7	1250	2.5	10	10	-10	50	NBR	331N03 ₃	-	496131	-	-	3	3	1.2	8056
	7	1250	2.5	10	10	-10	50	NBR	331N03 ₃	-	496482	-	-	3	3	1.2	8056
	7	1250	2.5	10	10	-10	50	NBR	331N03 ₃	-	496637	22	Ex tD A22 IP65 - T95°C	3	3	1.2	8056
1/2"	12	3000	2	10	10	-10	50	NBR	331N04 ₃	-	496131	-	-	3	3	1.2	8060
	12	3000	2	10	10	-10	50	NBR	331N04 ₃	-	496482	-	-	3	3	1.2	8060
	12	3000	2	10	10	-10	50	NBR	331N04 ₃	-	496637	22	Ex tD A22 IP65 - T95°C	3	3	1.2	8060

Notes:

1. DC voltage only. Minimum drop off voltage is 15% of nominal voltage (former DIN 19251)
2. With captured exhaust
3. With manual override



For this page	Port size	Orifice (mm)	Qn (l/min)	MOPD (bar)	Fluid Temp (°C)
From	1/4"	7	1250	10	-10
To	1/2"	12	3000	10	50

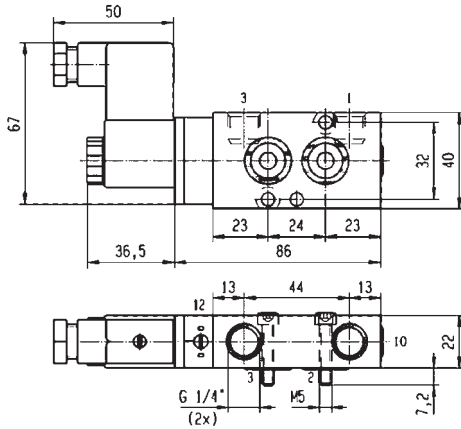

Drawing 8056

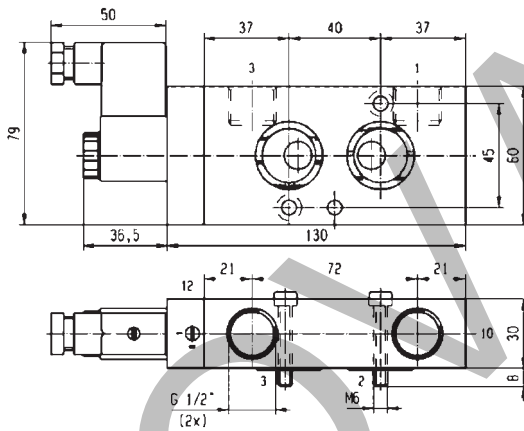

Drawing 8060

3/2

3 & 5 WAY PNEUMATIC VALVES FOR ACTUATOR CONTROL (NAMUR) PILOT OPERATED

ANODIZED ALUMINIUM

NAMUR

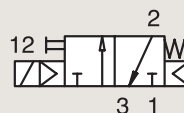

SOLENOID OPERATED - SPRING RETURN

Port size	Orifice Ø	Flow factor	Operating Pressure Differential			Fluid Temp.		Seat Seal	Valve Ref.	Housing Ref.	Coil Ref.	ATEX Zone	Protection Mode	Power		Coil Group	Dwg. No.
			Min	Max (MOPD)	DC bar	Min	Max							AC W	DC W		
1/2"	12	3000	2.5	10	10	-10	50	NBR	331N34 ₃	2995	481865	-	-	8	9	2.1	8210
	12	3000	2.5	10	10	-10	50	NBR	331N34 ₃	2995	495870	2-22	Ex nAC IIC T3/T4	8	9	2.1	8210
	12	3000	2.5	10	10	-10	50	NBR	331N34 ₃	-	495905	1-21	Ex d mb IIC T4	8	8	2.1	8210

Notes:

1. DC voltage only. Minimum drop off voltage is 15% of nominal voltage (former DIN 19251)
2. With captured exhaust
3. With manual override



For this page	Port size	Orifice (mm)	Qn (l/min)	MOPD (bar)	Fluid Temp (°C)
From	1/2"	12	3000	10	-10
To	1/2"	12	3000	10	50

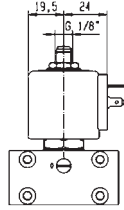
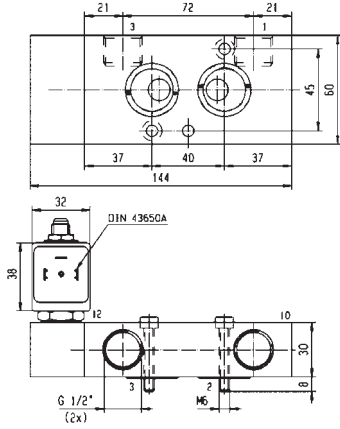

Drawing 8210

KOVALINK

3/2-5/2

3 & 5 WAY PNEUMATIC VALVES FOR ACTUATOR CONTROL (NAMUR) PILOT OPERATED

ANODIZED ALUMINIUM

NAMUR

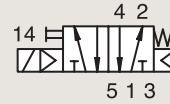

SOLENOID OPERATED - SPRING RETURN

Port size	Orifice Ø	Flow factor	Operating Pressure Differential			Fluid Temp.		Seat Seal	Valve Ref.	Housing Ref.	Coil Ref.	ATEX Zone	Protection Mode	Power		Coil Group	Dwg. No.
			Min	Max (MOPD)	DC bar	Min	Max							AC W	DC W		
BSP	mm	Qn l/min	bar	AC bar	DC bar	°C	°C										
1/8"-1/4"	4	600	2	10	10	-25	80	NBR	341N01 ₂₃	8993	488980	-	-	2	2.5	1.1	7301
	4	600	2	10	10	-25	80	NBR	341N11 ₂₃	8993	488980	-	-	2	2.5	1.1	7300
	4	600	2	10	10	-25	80	NBR	341N21 ₃	2995	481865	-	-	8	9	2.1	7311
	4	600	2	10	10	-25	80	NBR	341N21 ₃	4270	481000	-	-	8	8	2.1	7311
	4	600	2	-	10	-25	55	NBR	341N2190 ₃	2995	483580.01	0-20	Ex ia IIC T6	-	0.5 to 3	7.0/8.0	7874
	4	600	2	-	10	-25	55	NBR	341N2190 ₃	-	495910	0-20	Ex ia IIC T4 to T6	-	0.3 to 3	7.0/8.0	7874

Notes:

- 1. DC voltage only. Minimum drop off voltage is 15% of nominal voltage (former DIN 19251)
- 2. With captured exhaust
- 3. With manual override

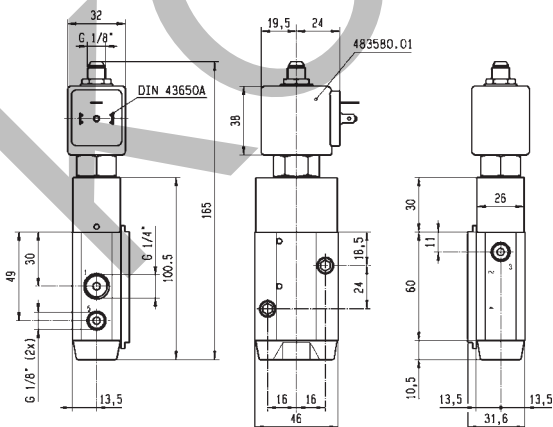

Drawing 7874



For this page	Port size	Orifice (mm)	Qn (l/min)	MOPD (bar)	Fluid Temp (°C)
From	1/8"-1/4"	4	600	10	-25
To	1/8"-1/4"	4	600	10	80

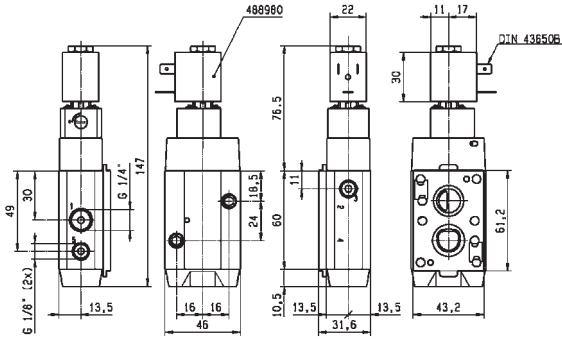

Drawing 7301

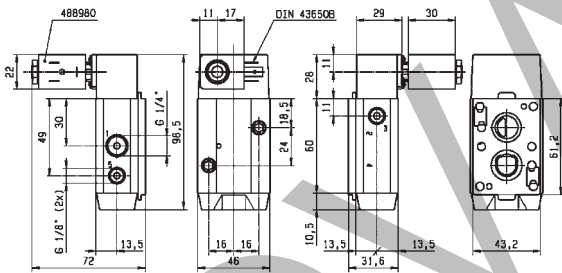

Drawing 7300

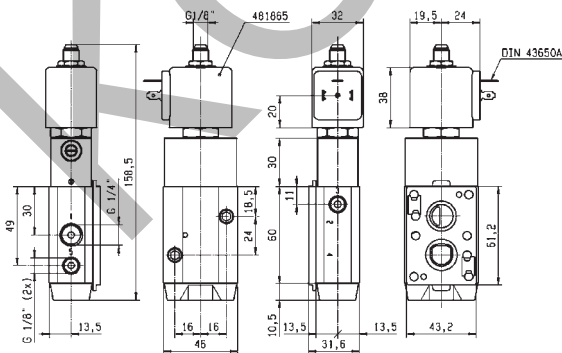

Drawing 7311

3/2-5/2

3 & 5 WAY PNEUMATIC VALVES FOR ACTUATOR CONTROL (NAMUR) PILOT OPERATED

ANODIZED ALUMINIUM

NAMUR

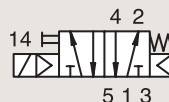

SOLENOID OPERATED - SPRING RETURN

Port size	Orifice Ø	Flow factor	Operating Pressure Differential		Fluid Temp.		Seat Seal	Valve Ref.	Housing Ref.	Coil Ref.	ATEX Zone	Protection Mode	Power		Coil Group	Dwg. No.	
			Min	Max (MOPD)	Min	Max							AC W	DC W			
BSP	mm	Qn l/min	bar	DC bar	°C	°C											
1/8"-1/4"	4	600	2	10	10	-25	80	NBR	341N31 ₃	2995	481865	-	-	8	9	2.1	7295
	4	600	2	10	10	-25	80	NBR	341N31 ₃	2995	495870	2-22	Ex nAC IIC T3/T4	8	9	2.1	7295
	4	600	2	10	10	-25	65	NBR	341N31 ₃	-	495905	1-21	Ex d mb IIC T4	8	8	2.1	7295
	4	600	2	10	10	-25	80	NBR	341N3102	2995	481865	-	-	8	9	2.1	7295
	4	600	2	10	10	-40	65	NBR	341N3108 ₃	2995	481865	-	-	8	9	2.1	7295
	4	600	2	10	10	-40	65	NBR	341N3108 ₃	4270	481000	-	-	8	8	2.1	7295
	4	600	2	10	10	-40	65	NBR	341N3128	2995	481865	-	-	8	9	2.1	7295
	4	600	2	10	10	-40	65	NBR	341N3128	4270	481865	-	-	8	9	2.1	7295
	4	600	2	-	10	-25	80	NBR	341N3130 ₁₃	2995	481865	-	-	-	9	2.1	7295
	4	600	2	-	10	-25	40	NBR	341N3130 ₁₃	-	492190	1-21	Ex e mb IIC T3/T4	-	9	2.1	7295
	4	600	2	-	10	-25	80	NBR	341N3130 ₁₃	-	495905	1-21	Ex d mb IIC T4	-	8	2.1	7295
	4	600	2	-	10	-10	55	NBR	341N3190	2995	483580.01	0-20	Ex ia IIC T6	-	0.5 to 3	7.0	7349
	4	600	2	-	10	-10	75	NBR	341N3190	-	488660.01	0-20	Ex ia IIC T6	-	0.3 to 3	7.0	7349
	4	600	2	-	10	-10	75	NBR	341N3190	-	495910	0-20	Ex ia IIC T4 to T6	-	0.3 to 3	7.0	7349
	4	600	2	-	10	-25	65	NBR	341N3196	2995	482740	-	-	-	1.6	6.0/8.0	8017
	4	600	2	10	10	-25	65	NBR	341N3196	-	495900	1-21	Ex d mb IIC T4 to T6	2.5	2	6.0/8.0	8017
	4	600	2	-	10	-25	65	NBR	341N3196	-	495910	0-20	Ex ia IIC T4 to T6	-	0.3 to 3	6.0/8.0	8017
	4	600	2	-	10	-25	55	NBR	341N3196 ₃₄	2995	483580.01	0-20	Ex ia IIC T6	-	0.5 to 3	6.0/7.0/8.0	8017
	4	600	2	-	10	-25	65	NBR	341N3196	2995	496125	2-22	Ex nAC IIC T5/T6	-	1.6	6.0/8.0	8017
	4	600	2	-	10	-25	65	NBR	341N3197 ₃	2995	482740	-	-	-	1.6	6.0/8.0	8017
4	600	2	10	10	-25	65	NBR	341N3197 ₃	-	495900	1-21	Ex d mb IIC T4 to T6	2.5	2	6.0/8.0	8017	
4	600	2	-	10	-25	65	NBR	341N3197 ₃	-	495910	0-20	Ex ia IIC T4 to T6	-	0.3 to 3	6.0/8.0	8017	
4	600	2	-	10	-25	65	NBR	341N3197 ₃	2995	496125	2-22	Ex nAC IIC T5/T6	-	1.6	6.0/8.0	8017	
4	600	2	-	10	-25	55	NBR	341N3197 ₃₄	2995	483580.01	0-20	Ex ia IIC T6	-	0.5 to 3	6.0/7.0/8.0	8017	

Notes:

1. DC voltage only. Minimum drop off voltage is 15% of nominal voltage (former DIN 19251)
2. With captured exhaust
3. With manual override
4. A minimum current of 65 mA is required with this coil configuration



For this page	Port size	Orifice (mm)	Qn (l/min)	MOPD (bar)	Fluid Temp (°C)
From	1/8"-1/4"	4	600	10	-40
To	1/8"-1/4"	4	600	10	80

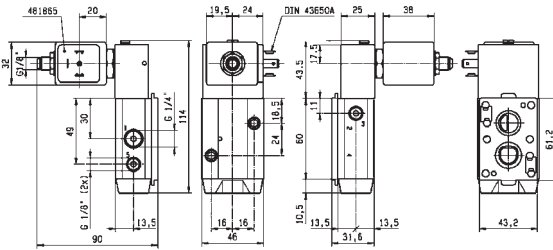

Drawing 7295

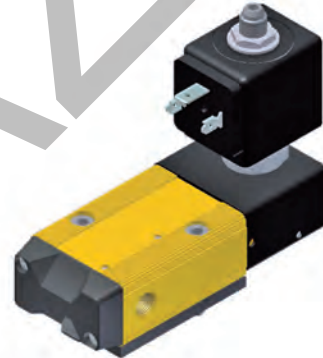
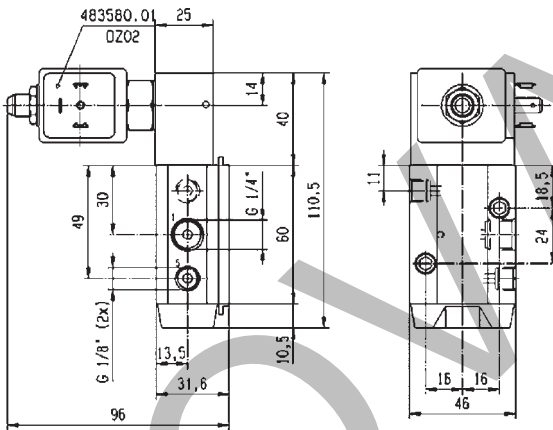

Drawing 7349

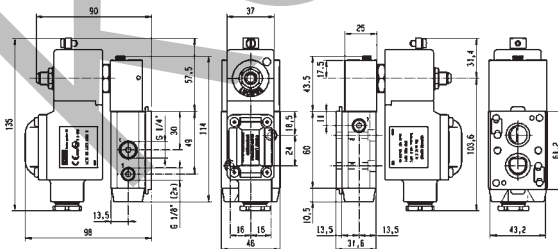

Drawing 8017

3/2-5/2

3 & 5 WAY PNEUMATIC VALVES FOR ACTUATOR CONTROL (NAMUR) PILOT OPERATED

ANODIZED ALUMINIUM

NAMUR

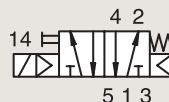

SOLENOID OPERATED - SPRING RETURN

Port size	Orifice Ø	Flow factor	Operating Pressure Differential			Fluid Temp.		Seat Seal	Valve Ref.	Housing Ref.	Coil Ref.	ATEX Zone	Protection Mode	Power		Coil Group	Dwg. No.
			Min	Max (MOPD)	DC	Min	Max							AC W	DC W		
BSP	1	Qn l/min	bar	AC bar	DC bar	°C	°C										
1/4"	8	1400	2	-	10	-25	55	NBR	341N3290	2995	483580.01	0-20	Ex ia IIC T6	-	0.5 to 3	7.0	7350
	8	1400	2	-	10	-25	75	NBR	341N3290	-	488660.01	0-20	Ex ia IIC T6	-	0.3 to 3	7.0	7350
	8	1400	2	-	10	-25	75	NBR	341N3290	-	495910	0-20	Ex ia IIC T4 to T6	-	0.3 to 3	7.0	7350
	8	1400	2	-	10	-25	65	NBR	341N3296	2995	482740	-	-	-	1.6	6.0/8.0	8029
	8	1400	2	10	10	-25	65	NBR	341N3296	-	495900	1-21	Ex d mb IIC T4 to T6	2.5	2	6.0/8.0	8029
	8	1400	2	-	10	-25	65	NBR	341N3296	-	495910	0-20	Ex ia IIC T4 to T6	-	0.3 to 3	6.0/8.0	8029
	8	1400	2	-	10	-20	80	NBR	341N3296	2995	496125	2-22	Ex nAC IIC T5/T6	-	1.6	6.0/8.0	8029
	8	1400	2	-	10	-20	55	NBR	341N3296 ₂	2995	483580.01	0-20	Ex ia IIC T6	-	0.5 to 3	6.0/7.0/8.0	8029
	8	1400	2	-	10	-25	65	NBR	341N3297 ₁	2995	482740	-	-	-	1.6	6.0/8.0	8029
	8	1400	2	10	10	-25	65	NBR	341N3297 ₁	-	495900	1-21	Ex d mb IIC T4 to T6	2.5	2	6.0/8.0	8029
	8	1400	2	-	10	-25	65	NBR	341N3297 ₁	-	495910	0-20	Ex ia IIC T4 to T6	-	0.3 to 3	6.0/8.0	8029
	8	1400	2	-	10	-20	80	NBR	341N3297 ₁	2995	496125	2-22	Ex nAC IIC T5/T6	-	1.6	6.0/8.0	8029
	8	1400	2	-	10	-20	55	NBR	341N3297 ₁₂	2995	483580.01	0-20	Ex ia IIC T6	-	0.5 to 3	6.0/7.0/8.0	8029
	7	1250	2.5	10	10	-10	50	NBR	341N05 ₁	-	496131	-	-	3	3	1.2	8162
	7	1250	2.5	10	10	-10	50	NBR	341N05 ₁	-	496482	-	-	3	3	1.2	8162
7	1250	2.5	10	10	-10	50	NBR	341N05 ₁	-	496637	22	Ex tD A22 IP65 - T95°C	3	3	1.2	8162	

Notes:

1. With manual override
2. A minimum current of 65 mA is required with this coil configuration

3/2-5/2

3 & 5 WAY PNEUMATIC VALVES FOR ACTUATOR CONTROL (NAMUR) PILOT OPERATED

ANODIZED ALUMINIUM NAMUR

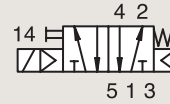

SOLENOID OPERATED - SPRING RETURN

Port size	Orifice Ø	Flow factor	Operating Pressure Differential			Fluid Temp.		Seat Seal	Valve Ref.	Housing Ref.	Coil Ref.	ATEX Zone	Protection Mode	Power		Coil Group	Dwg. No.
			Min	Max (MOPD)	DC	Min	Max							AC W	DC W		
BSP	mm	Qn l/min	bar	AC bar	DC bar	°C	°C										
1/4"	7	1200	2.5	10	10	-10	50	NBR	341N0502	-	496131	-	-	3	3	1.2	8253
	7	1200	2.5	10	10	-10	50	NBR	341N0502	-	496482	-	-	3	3	1.2	8253
	7	1200	2.5	10	10	-10	50	NBR	341N35 ₃	2995	481865	-	-	8	9	2.1	8213
	7	1200	2.5	10	10	-10	50	NBR	341N35 ₃	2995	495870	2-22	Ex nAC IIC T3/T4	8	9	2.1	8213
	7	1200	2.5	10	10	-10	50	NBR	341N35 ₃	-	495905	1-21	Ex d mb IIC T4	8	8	2.1	8213
	7	1200	2.5	10	10	-10	50	NBR	341N3502	2995	481865	-	-	8	9	2.1	8254
	7	1200	2.5	10	10	-10	50	NBR	341N3502	4270	481000	-	-	8	8	2.1	8254
	8	1400	2	10	10	-25	80	NBR	341N02 ₂₃	8993	488980	-	-	2	2.5	1.1	7313

Notes:

1. DC voltage only. Minimum drop off voltage is 15% of nominal voltage (former DIN 19251)
2. With captured exhaust
3. With manual override

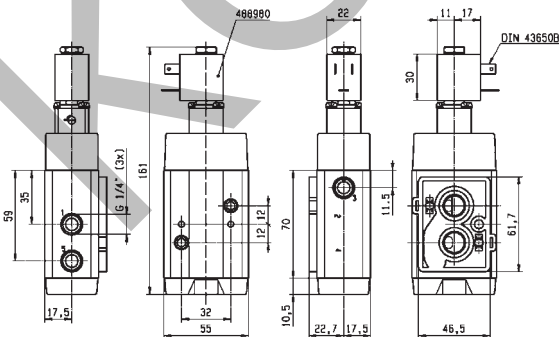

Drawing 7313

3 & 5 WAY PNEUMATIC DISTRIBUTORS



For this page	Port size	Orifice (mm)	Qn (l/min)	MOPD (bar)	Fluid Temp (°C)
From	1/4"	7	1200	10	-25
To	1/4"	8	1400	10	80

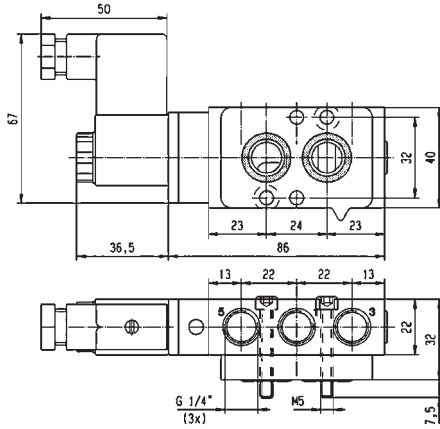

Drawing 8253

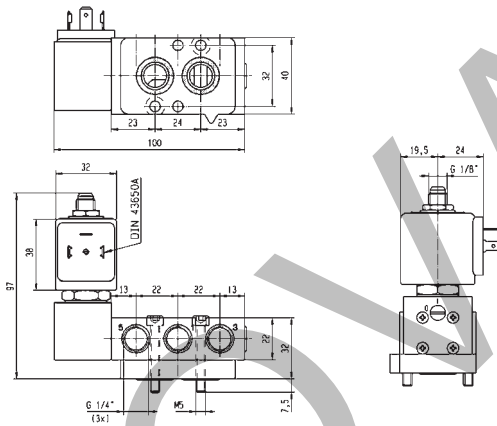

Drawing 8213

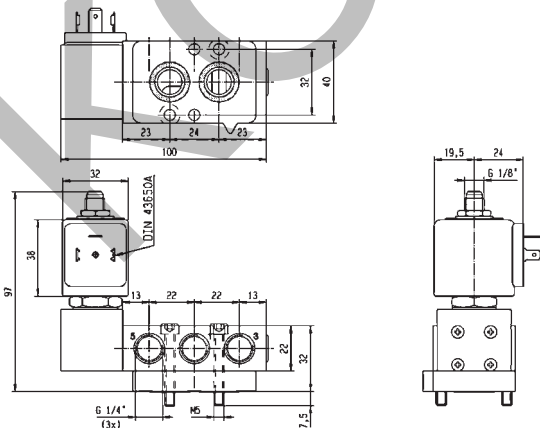

Drawing 8254

3/2-5/2

3 & 5 WAY PNEUMATIC VALVES FOR ACTUATOR CONTROL (NAMUR) PILOT OPERATED

ANODIZED ALUMINIUM

NAMUR

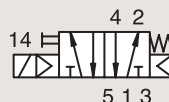

SOLENOID OPERATED - SPRING RETURN

Port size	Orifice Ø	Flow factor	Operating Pressure Differential			Fluid Temp.		Seat Seal	Valve Ref.	Housing Ref.	Coil Ref.	ATEX Zone	Protection Mode	Power		Coil Group	Dwg. No.
			Min	Max (MOPD)		Min	Max							AC W	DC W		
BSP	1	Qn l/min	bar	AC bar	DC bar	°C	°C										
1/4"	8	1400	2	10	10	-25	80	NBR	341N12 ₂₃	8993	488980	-	-	2	2.5	1.1	7312
	8	1400	2	10	10	-25	80	NBR	341N22 ₃	2995	481865	-	-	8	9	2.1	7318
	8	1400	2	10	10	-25	80	NBR	341N22 ₃	4270	481000	-	-	8	8	2.1	7318
	8	1400	2	10	10	-25	80	NBR	341N32 ₃	2995	481865	-	-	8	9	2.1	7317
	8	1400	2	10	10	-25	80	NBR	341N32 ₃	2995	495870	2-22	Ex nAC IIC T3/T4	8	9	2.1	7317
	8	1400	2	10	10	-25	80	NBR	341N32 ₃	-	495905	1-21	Ex d mb IIC T4	8	8	2.1	7317
	8	1400	2	10	10	-25	80	NBR	341N3202	2995	481865	-	-	8	9	2.1	7317
	8	1400	2	10	10	-25	80	NBR	341N3202	2995	495870	2-22	Ex nAC IIC T3/T4	8	9	2.1	7317
8	1400	2	10	10	-25	80	NBR	341N3202	-	495905	1-21	Ex d mb IIC T4	8	8	2.1	7317	

Notes:

1. DC voltage only. Minimum drop off voltage is 15% of nominal voltage (former DIN 19251)
2. With captured exhaust
3. With manual override



For this page	Port size	Orifice (mm)	Qn (l/min)	MOPD (bar)	Fluid Temp (°C)
From	1/4"	8	1400	10	-25
To	1/4"	8	1400	10	80

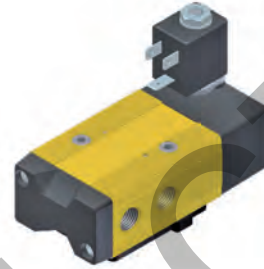
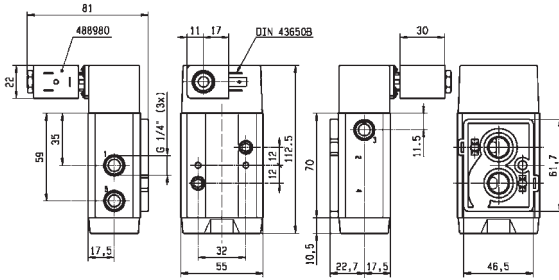

Drawing 7312

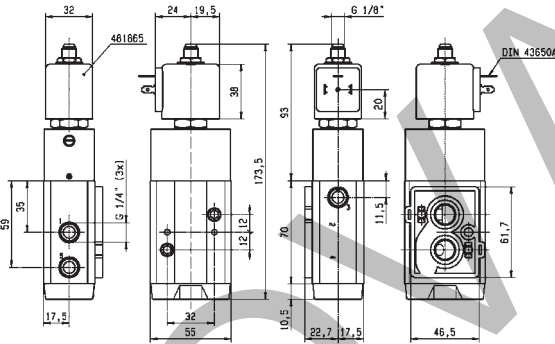

Drawing 7318

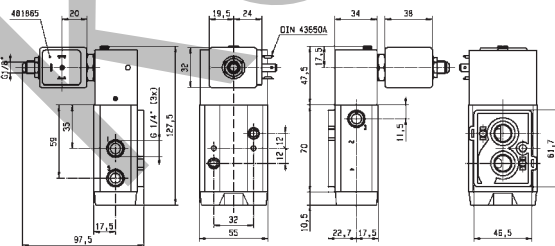

Drawing 7317

5/2

3 & 5 WAY PNEUMATIC VALVES FOR ACTUATOR CONTROL (NAMUR) PILOT OPERATED

ANODIZED ALUMINIUM NAMUR

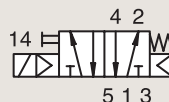

SOLENOID OPERATED - SPRING RETURN

Port size	Orifice Ø	Flow factor	Operating Pressure Differential			Fluid Temp.		Seat Seal	Valve Ref.	Housing Ref.	Coil Ref.	ATEX Zone	Protection Mode	Power		Coil Group	Dwg. No.
			Min	Max (MOPD)	DC bar	Min	Max							AC W	DC W		
BSP	1	Qn l/min	bar	AC bar	DC bar	°C	°C										
1/4"	7	1250	2.5	10	10	-20	50	NBR	341N03 ₃	-	496131	-	-	3	3	1.2	8063
	7	1250	2.5	10	10	-20	50	NBR	341N03 ₃	-	496482	-	-	3	3	1.2	8063
	7	1250	2.5	10	10	-20	50	NBR	341N03 ₃	-	496637	22	Ex tD A22 IP65 - T95°C	3	3	1.2	8063
1/2"	12	3000	2	10	10	-10	50	NBR	341N04 ₃	-	496131	-	-	3	3	1.2	8065
	12	3000	2	10	10	-10	50	NBR	341N04 ₃	-	496482	-	-	3	3	1.2	8065
	12	3000	2	10	10	-10	50	NBR	341N04 ₃	-	496637	22	Ex tD A22 IP65 - T95°C	3	3	1.2	8065
	12	3000	2.5	10	10	-20	50	NBR	341N34 ₃	2995	481865	-	-	8	9	2.1	8211
	12	3000	2.5	10	10	-20	50	NBR	341N34 ₃	2995	495870	2-22	Ex nAC IIC T3/T4	8	9	2.1	8211
	12	3000	2.5	10	10	-20	50	NBR	341N34 ₃	-	495905	1-21	Ex d mb IIC T4	8	8	2.1	8211
	12	3000	2.5	10	10	-20	50	NBR	341N34 ₃	-	495905	1-21	Ex d mb IIC T4	8	8	2.1	8211

Notes:

1. DC voltage only. Minimum drop off voltage is 15% of nominal voltage (former DIN 19251)
2. With captured exhaust
3. With manual override



For this page	Port size	Orifice (mm)	Qn (l/min)	MOPD (bar)	Fluid Temp (°C)
From	1/4"	7	1250	10	-10
To	1/2"	12	3000	10	50

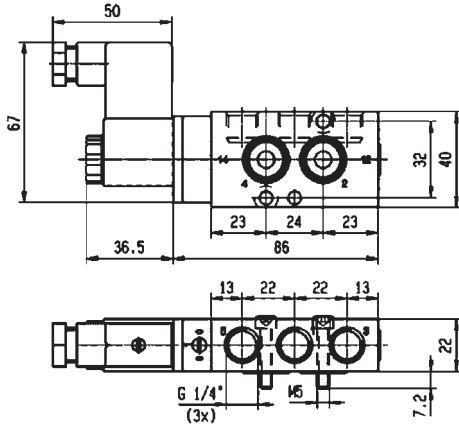

Drawing 8063

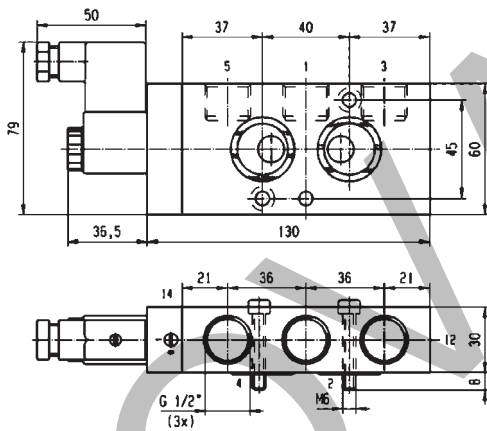

Drawing 8065

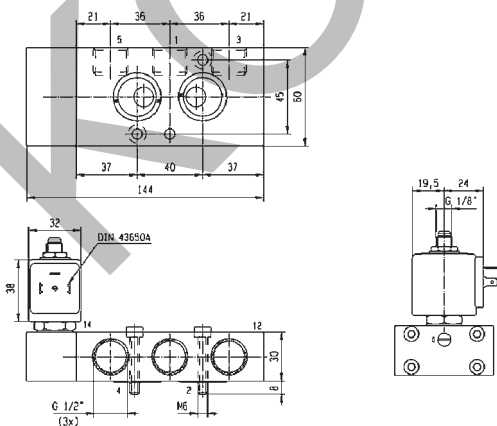

Drawing 8211

5/2

3 & 5 WAY PNEUMATIC VALVES FOR ACTUATOR CONTROL (NAMUR) PILOT OPERATED

ANODIZED ALUMINIUM

NAMUR

DUAL SOLENOIDS

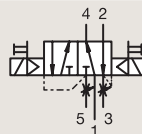

Port size	Orifice Ø	Flow factor	Operating Pressure Differential			Fluid Temp.		Seat Seal	Valve Ref.	Housing Ref.	Coil Ref.	ATEX Zone	Protection Mode	Power		Coil Group	Dwg. No.
			Min	Max (MOPD)	DC	Min	Max							AC W	DC W		
BSP	mm	Qn l/min	bar	AC bar	DC bar	°C	°C										
1/8"- 1/4"	4	400	2	10	10	-25	50	NBR	347N11 ₁₂	-	482606	1-21	Ex mb IIC T4/T5	2	2.5	1.1	7305
	4	400	2	10	10	-25	80	NBR	347N11 ₁₂	8993	488980	-	-	2	2.5	1.1	7305
	4	400	2	10	10	-25	80	NBR	347N31 ₂	2995	481865	-	-	8	9	2.1	7297
	4	400	2	10	10	-25	80	NBR	347N31 ₂	2995	495870	2-22	Ex nAC IIC T3/T4	8	9	2.1	7297
	4	400	2	10	10	-25	80	NBR	347N31 ₂	-	495905	1-21	Ex d mb IIC T4	8	8	2.1	7297
	4	400	2	-	10	-25	55	NBR	347N3190	2995	483580.01	0-20	Ex ia IIC T6	-	0.5 to 3	7.0	8141
	4	400	2	-	10	-25	65	NBR	347N3197 ₂	2995	482740	-	-	-	1.6	3.0/6.0/8.0	7297
	4	400	2	10	10	-25	65	NBR	347N3197 ₂	-	495900	1-21	Ex d mb IIC T4 to T6	2.5	2	3.0/6.0/8.0	7297
	4	400	2	-	10	-25	65	NBR	347N3197 ₂	-	495910	0-20	Ex ia IIC T4 to T6	-	0.3 to 3	3.0/6.0/8.0	7297
	4	400	2	-	10	-25	65	NBR	347N3197 ₂	2995	496125	2-22	Ex nAC IIC T5/T6	-	1.6	3.0/6.0/8.0	7297
	4	400	2	-	10	-25	55	NBR	347N3197 ₂₃	2995	483580.01	0-20	Ex ia IIC T6	-	0.5 to 3	6.0/7.0/8.0	7297

Notes:

1. With captured exhaust
2. With manual override
3. A minimum current of 65 mA is required with this coil configuration



For this page	Port size	Orifice (mm)	Qn (l/min)	MOPD (bar)	Fluid Temp (°C)
From	1/8"-1/4"	4	400	10	-25
To	1/8"-1/4"	4	400	10	80

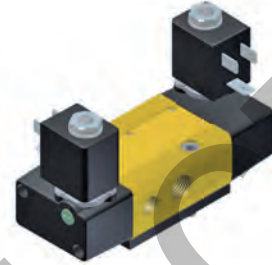
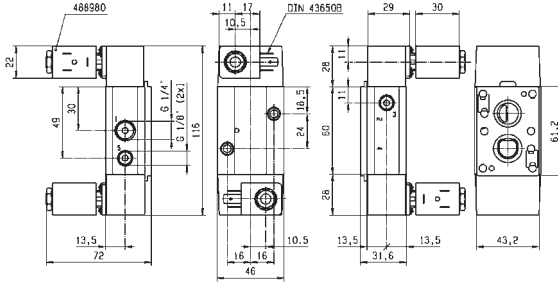

Drawing 7305

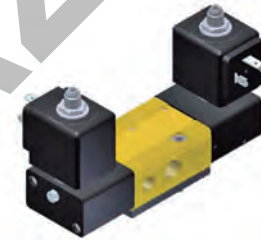
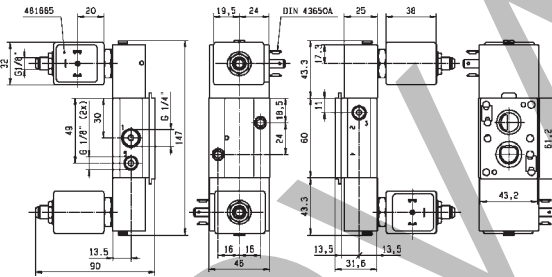

Drawing 7297

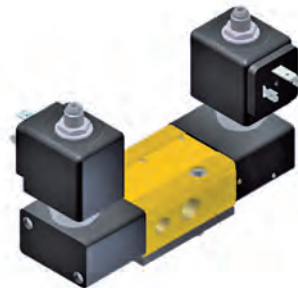
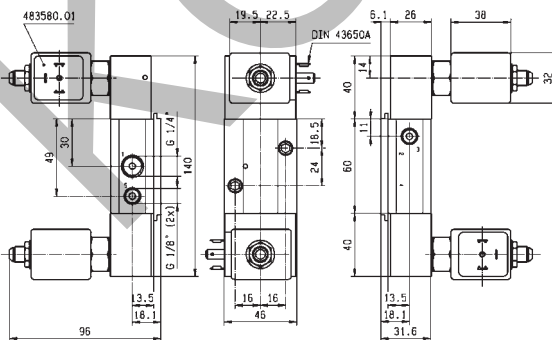

Drawing 8141

5/2

3 & 5 WAY PNEUMATIC VALVES FOR ACTUATOR CONTROL (NAMUR) PILOT OPERATED

ANODIZED ALUMINIUM

NAMUR

DUAL SOLENOIDS



Port size	Orifice Ø	Flow factor	Operating Pressure Differential		Fluid Temp.		Seat Seal	Valve Ref.	Housing Ref.	Coil Ref.	ATEX Zone	Protection Mode	Power		Coil Group	Dwg. No.	
			Min	Max (MOPD) DC bar	Min	Max							AC W	DC W			
1/4"	7	1250	1.5	10	10	-10	50	NBR	347N03 ₂	-	496131	-	-	3	3	1.2	8057
	7	1250	1.5	10	10	-10	50	NBR	347N03 ₂	-	496482	-	-	3	3	1.2	8057
	7	1250	1.5	10	10	-10	50	NBR	347N03 ₂	-	496637	22	Ex tD A22 IP65 - T95°C	3	3	1.2	8057
	7	1250	2.5	10	10	-10	120	NBR	347N33 ₂	2995	481865	-	-	8	9	2.1	8209
	7	1250	2.5	10	10	-10	120	NBR	347N33 ₂	2995	495870	2-22	Ex nAC IIC T3/T4	8	9	2.1	8209
	7	1250	2.5	10	10	-10	120	NBR	347N33 ₂	-	495905	1-21	Ex d mb IIC T4	8	8	2.1	8209
	8	1400	2	10	10	-10	65	NBR	347N12 ₁₂	-	482606	1-21	Ex mb IIC T4/T5	2	2.5	1.1	7315
	8	1400	2	10	10	-25	80	NBR	347N12 ₁₂	8993	488980	-	-	2	2.5	1.1	7315
	8	1400	2	10	10	-25	80	NBR	347N32 ₂	2995	481865	-	-	8	9	2.1	7320
	8	1400	2	10	10	-25	80	NBR	347N32 ₂	2995	495870	2-22	Ex nAC IIC T3/T4	8	9	2.1	7320
	8	1400	2	10	10	-25	80	NBR	347N32 ₂	-	495905	1-21	Ex d mb IIC T4	8	8	2.1	7320

Notes:

- 1. With captured exhaust
- 2. With manual override
- 3. A minimum current of 65 mA is required with this coil configuration

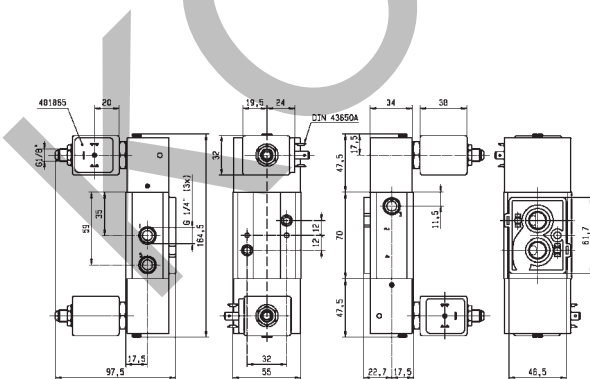

Drawing 7320

5/2

3 & 5 WAY PNEUMATIC VALVES FOR ACTUATOR CONTROL (NAMUR) PILOT OPERATED

ANODIZED ALUMINIUM

NAMUR

DUAL SOLENOIDS

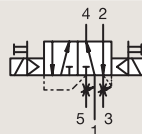

Port size	Orifice Ø 1	Flow factor Qn l/min	Operating Pressure Differential		Fluid Temp.		Seat Seal	Valve Ref.	Housing Ref.	Coil Ref.	ATEX Zone	Protection Mode	Power		Coil Group	Dwg. No.	
			Min	Max (MOPD) DC bar	Min	Max							AC W	DC W			
1/2"	12	3000	1.5	10	10	-10	50	NBR	347N04 ₂	-	496131	-	-	3	3	1.2	8154
	12	3000	1.5	10	10	-10	50	NBR	347N04 ₂	-	496482	-	-	3	3	1.2	8154
	12	3000	1.5	10	10	-10	50	NBR	347N04 ₂	-	496637	22	Ex tD A22 IP65 - T95°C	3	3	1.2	8154
	12	3000	2.5	10	10	-10	120	NBR	347N34 ₂	2995	481865	-	-	8	9	2.1	8212
	12	3000	2.5	10	10	-10	120	NBR	347N34 ₂	2995	495870	2-22	Ex nAC IIC T3/T4	8	9	2.1	8212
	12	3000	2.5	10	10	-10	120	NBR	347N34 ₂	-	495905	1-21	Ex d mb IIC T4	8	8	2.1	8212

Notes:

1. With captured exhaust
2. With manual override
3. A minimum current of 65 mA is required with this coil configuration

5/3

3 & 5 WAY PNEUMATIC VALVES FOR ACTUATOR CONTROL (NAMUR) PILOT OPERATED

ANODIZED ALUMINIUM NAMUR

W1 CLOSED CENTER POSITION

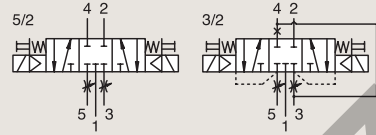

Port size	Orifice Ø	Flow factor	Operating Pressure Differential			Fluid Temp.		Seat Seal	Valve Ref.	Housing Ref.	Coil Ref.	ATEX Zone	Protection Mode	Power		Coil Group	Dwg. No.
			Min	Max (MOPD)	Min	Max	AC W							DC W			
BSP	mm	Qn l/min	bar	AC bar	DC bar	°C	°C										
1/8"-1/4"	4	400	2	10	10	-25	80	NBR	342N11 ₁₂	-	482606	1-21	Ex mb IIC T4/T5	2	2.5	1.1	7305
	4	400	2	10	10	-25	80	NBR	342N11 ₁₂	8993	488980	-	-	2	2.5	1.1	7305
	4	400	2	-	10	-10	65	NBR	342N3197 ₂	-	495910	0-20	Ex ia IIC T4 to T6	-	0.3 to 3	6.0/8.0	7297
	4	400	2	-	10	-10	55	NBR	342N3197 ₂₃	2995	483580.01	0-20	Ex ia IIC T6	-	0.5 to 3	6.0/7.0/8.0	7297
1/4"	7	1250	3	10	10	-20	50	NBR	342N03 ₂	-	496131	-	-	3	3	1.2	8057
	7	1250	3	10	10	-20	50	NBR	342N03 ₂	-	496482	-	-	3	3	1.2	8057
	7	1250	3	10	10	-10	50	NBR	342N03 ₂	-	496637	22	Ex tD A22 IP65 - T95°C	3	3	1.2	8057
	7	1250	2.5	10	10	-20	50	NBR	342N33 ₂	2995	481865	-	-	8	9	2.1	8209
	7	1250	2.5	10	10	-20	50	NBR	342N33 ₂	2995	495870	2-22	Ex nAC IIC T3/T4	8	9	2.1	8209
	7	1250	2.5	10	10	-20	50	NBR	342N33 ₂	-	495905	1-21	Ex d mb IIC T4	8	8	2.1	8209
	7	1250	2.5	10	10	-20	50	NBR	342N33 ₂	-	495905	1-21	Ex d mb IIC T4	8	8	2.1	8209

Notes:

1. With captured exhaust
2. With manual override
3. A minimum current of 65 mA is required with this coil configuration

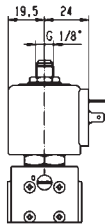
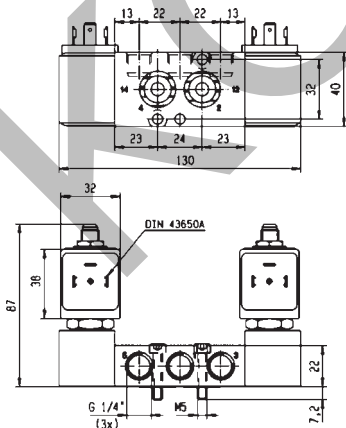

Drawing 8209

5/3

3 & 5 WAY PNEUMATIC VALVES FOR ACTUATOR CONTROL (NAMUR) PILOT OPERATED

ANODIZED ALUMINIUM

NAMUR

W3 EXHAUSTED IN CENTER POSITION

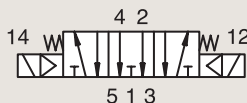

Port size	Orifice Ø	Flow factor	Operating Pressure Differential			Fluid Temp.		Seat Seal	Valve Ref.	Housing Ref.	Coil Ref.	ATEX Zone	Protection Mode	Power		Coil Group	Dwg. No.
			Min	Max (MOPD)	DC bar	Min	Max							AC W	DC W		
BSP	1	Qn l/min	bar	AC bar	DC bar	°C	°C										
1/4"	7	1250	3	10	10	-20	50	NBR	343N03	-	496131	-	-	3	3	1.2	8057
	7	1250	3	10	10	-20	50	NBR	343N03	-	496482	-	-	3	3	1.2	8057
	7	1250	3	10	10	-10	50	NBR	343N03	-	496637	22	Ex tD A22 IP65 - T95°C	3	3	1.2	8057

Notes:

1. With manual override



For this page	Port size	Orifice (mm)	Qn (l/min)	MOPD (bar)	Fluid Temp (°C)
From	1/4"	7	1250	10	-10
To	1/4"	7	1250	10	50

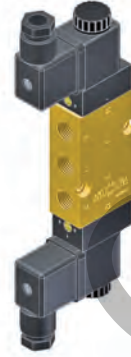
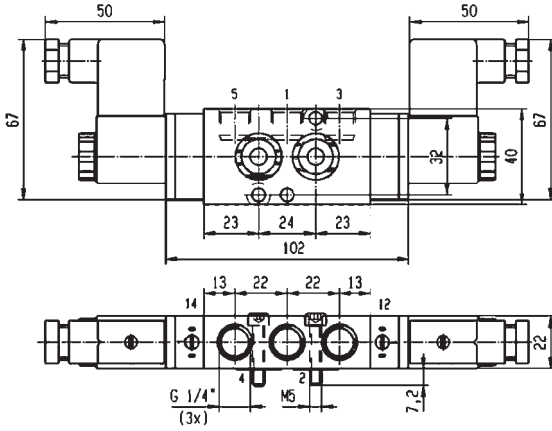

Drawing 8057

KOOLVARI.COM

3/2-5/2

3 & 5 WAY PNEUMATIC VALVES FOR ACTUATOR CONTROL (NAMUR) PILOT OPERATED

ANODIZED ALUMINIUM

NAMUR

CONTROL BY ELECTRIC IMPULSE

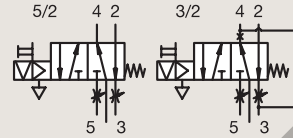

Port size	Orifice Ø	Flow factor	Operating Pressure Differential			Fluid Temp.		Seat Seal	Valve Ref.	Housing Ref.	Coil Ref.	ATEX Zone	Protection Mode	Power		Coil Group	Dwg. No.
			Min	Max (MOPD)	Min	Max	AC W							DC W			
BSP	mm	Qn l/min	bar	AC bar	DC bar	°C	°C										
1/8"-1/4"	4	600	2	-	10	-25	80	FKM/NBR	345N31 ₁₂	4269	485400	-	-	-	13	4.0	7295

Notes:

- 1.Pilot seat in FKM
- 2.With manual override

ANODIZED ALUMINIUM

NAMUR

SOLENOID OPERATED - SPRING RETURN

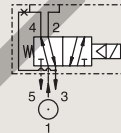

Port size	Orifice Ø	Flow factor	Operating Pressure Differential			Fluid Temp.		Seat Seal	Valve Ref.	Housing Ref.	Coil Ref.	ATEX Zone	Protection Mode	Power		Coil Group	Dwg. No.
			Min	Max (MOPD)	Min	Max	AC W							DC W			
BSP	mm	Qn l/min	bar	AC bar	DC bar	°C	°C										
1/8"-1/4"	4	355	1	10	10	-10	75	NBR	341L9504 ₁₂	-	482605	1-21	Ex mb IIC T4	4	5	1.1	7009
	4	355	1	10	10	-10	75	NBR	341L9504 ₁₂	-	482606	1-21	Ex mb IIC T4/T5	2	2.5	1.1	7009
	4	355	1	10	10	-10	75	NBR	341L9504 ₁₂	8993	488980	-	-	2	2.5	1.1	7009
	4	355	1	10	10	-10	75	NBR	341L9504 ₁₂	8993	495865	2-22	Ex nAC IIC T5	2	2.5	1.1	7009
	4	355	1	10	10	-10	75	NBR	341L9534 ₁₂	2995	481865	-	-	8	9	2.1/7.0	3990
	4	355	1	10	10	-10	75	NBR	341L9534 ₁₂	2995	495870	2-22	Ex nAC IIC T3/T4	8	9	2.1/7.0	3990
	4	355	1	10	10	-10	75	NBR	341L9534 ₁₂	-	495905	1-21	Ex d mb IIC T4	8	8	2.1/7.0	3990

Notes:

- 1.Pilot seat in FKM
- 2.With manual override



For this page	Port size	Orifice (mm)	Qn (l/min)	MOPD (bar)	Fluid Temp (°C)
From	1/8"-1/4"	4	355	10	-25
To	1/8"-1/4"	4	600	10	80

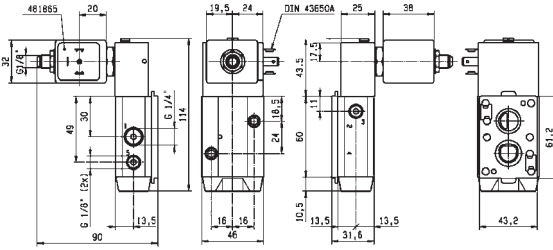

Drawing 7295

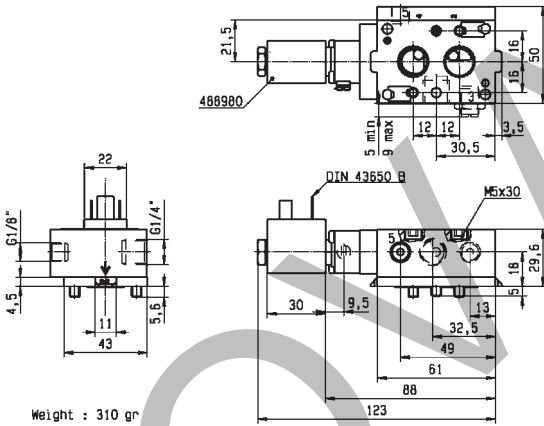

Drawing 7009

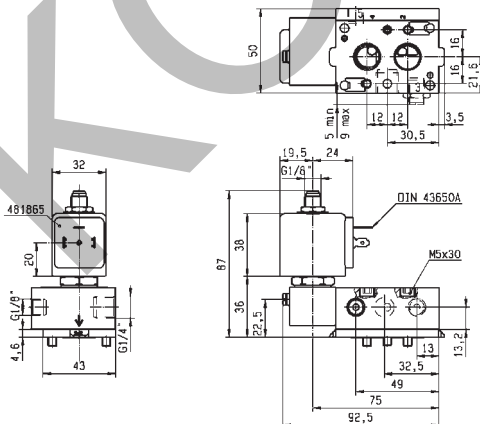

Drawing 3990

3/2-5/2

3 & 5 WAY PNEUMATIC VALVES FOR ACTUATOR CONTROL (NAMUR) PILOT OPERATED

ANODIZED ALUMINIUM

NAMUR

SOLENOID OPERATED - SPRING RETURN

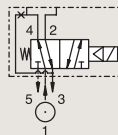

Port size	Orifice Ø	Flow factor	Operating Pressure Differential			Fluid Temp.		Seat Seal	Valve Ref.	Housing Ref.	Coil Ref.	ATEX Zone	Protection Mode	Power		Coil Group	Dwg. No.
			Min	Max (MOPD)	AC bar	DC bar	Min							Max	AC W		
1/8"- 1/4"	4	355	2	-	10	-10	55	NBR	341L9594 ₁	2995	483580.01	0-20	Ex ia IIC T6	-	0.5 to 3	7.0	3992
	4	355	1	-	10	-10	75	NBR	341L9594 ₁	-	495910	0-20	Ex ia IIC T4 to T6	-	0.3 to 3	7.0	3992
	4	355	2	-	10	-10	75	NBR/PUR	341L9597 ₂	2995	482740	-	-	-	1.6	6.0/8.0	8025
	4	355	2	10	10	-10	75	NBR/PUR	341L9597 ₂	-	495900	1-21	Ex d mb IIC T4 to T6	2.5	2	6.0/8.0	8025
	4	355	2	-	10	-10	75	NBR/PUR	341L9597 ₂	-	495910	0-20	Ex ia IIC T4 to T6	-	0.3 to 3	6.0/8.0	8025
	4	355	2	-	10	-10	75	NBR/PUR	341L9597 ₂	2995	496125	2-22	Ex nAC IIC T5/T6	-	1.6	6.0/8.0	8025
	4	355	2	-	10	-25	55	NBR/PUR	341L9598	2995	483580.01	0-20	Ex ia IIC T6	-	0.5 to 3	7.0	3992

Notes:

1. Pilot seat in FKM
2. With manual override



For this page	Port size	Orifice (mm)	Qn (l/min)	MOPD (bar)	Fluid Temp (°C)
From	1/8"-1/4"	4	355	10	-25
To	1/8"-1/4"	4	355	10	75

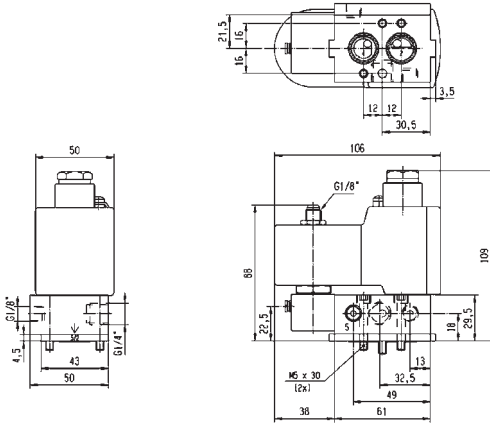

Drawing 3992

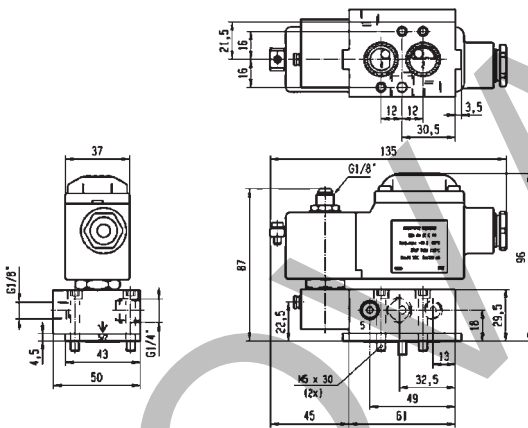

Drawing 8025

3/2

3 & 5 WAY PNEUMATIC VALVES FOR ACTUATOR CONTROL (NAMUR) EXTERNALLY OPERATED

ANODIZED ALUMINIUM

NAMUR

AIR OPERATED - SPRING RETURN

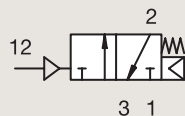

Port size	Orifice Ø 1	Flow factor Qn l/min	Operating Pressure Differential			Fluid Temp.		Seat Seal	Valve Ref.	Housing Ref.	Coil Ref.	ATEX Zone	Protection Mode	Power		Coil Group	Dwg. No.
			Min	Max (MOPD)	DC bar	Min	Max							AC W	DC W		
1/4"	7	1250	2.5	10	10	-10	50	NBR	531N03	-	-	-	-	-	-	-	8058
1/2"	12	3000	2.5	10	10	-10	50	NBR	531N04	-	-	-	-	-	-	-	8061

KONVANT



For this page	Port size	Orifice (mm)	Qn (l/min)	MOPD (bar)	Fluid Temp (°C)
From	1/4"	7	1250	10	-10
To	1/2"	12	3000	10	50

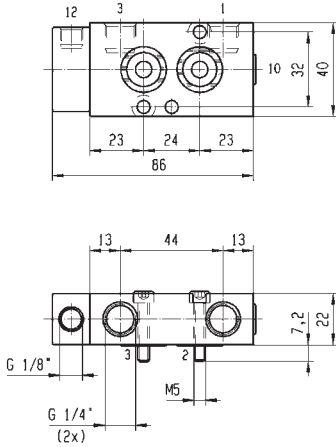

Drawing 8058

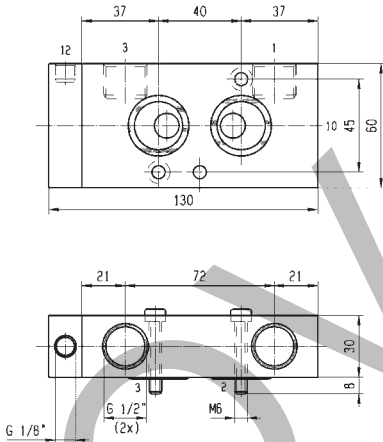

Drawing 8061

3/2-5/2

3 & 5 WAY PNEUMATIC VALVES FOR ACTUATOR CONTROL (NAMUR) EXTERNALLY OPERATED

ANODIZED ALUMINIUM

NAMUR

AIR OPERATED - SPRING RETURN

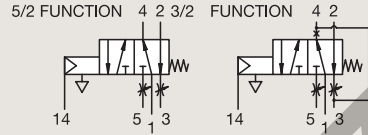

Port size	Orifice Ø	Flow factor	Operating Pressure Differential			Fluid Temp.		Seat Seal	Valve Ref.	Housing Ref.	Coil Ref.	ATEX Zone	Protection Mode	Power		Coil Group	Dwg. No.
			Min	Max (MOPD)	DC bar	Min	Max							AC W	DC W		
BSP	1	Qn l/min	bar	AC bar	DC bar	°C	°C										
1/8"-1/4"	4	600	2	10	10	-40	50	NBR	541N0108	-	-	-	-	-	-	-	7309

KONVAZ



For this page	Port size	Orifice (mm)	Qn (l/min)	MOPD (bar)	Fluid Temp (°C)
From	1/8"-1/4"	4	600	10	-40
To	1/8"-1/4"	4	600	10	80

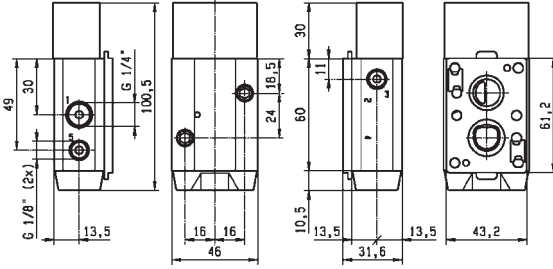

Drawing 7309

KOVAR

5/2

3 & 5 WAY PNEUMATIC VALVES FOR ACTUATOR CONTROL (NAMUR) EXTERNALLY OPERATED

ANODIZED ALUMINIUM

NAMUR

5/2 FUNCTION

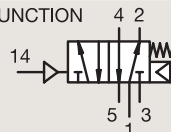

AIR OPERATED - SPRING RETURN

Port size	Orifice Ø	Flow factor	Operating Pressure Differential			Fluid Temp.		Seat Seal	Valve Ref.	Housing Ref.	Coil Ref.	ATEX Zone	Protection Mode	Power		Coil Group	Dwg. No.
			Min	Max (MOPD)	DC bar	Min	Max							AC W	DC W		
BSP	1	Qn l/min	bar	AC bar	DC bar	°C	°C										
1/4"	7	1250	2.5	10	10	-10	50	NBR	541N03	-	-	-	-	-	-	-	8064
1/2"	12	3000	2.5	10	10	-10	50	NBR	541N04	-	-	-	-	-	-	-	8066

ANODIZED ALUMINIUM

NAMUR

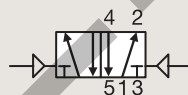

AIR OPERATED AND RETURN

Port size	Orifice Ø	Flow factor	Operating Pressure Differential			Fluid Temp.		Seat Seal	Valve Ref.	Housing Ref.	Coil Ref.	ATEX Zone	Protection Mode	Power		Coil Group	Dwg. No.
			Min	Max (MOPD)	DC bar	Min	Max							AC W	DC W		
BSP	1	Qn l/min	bar	AC bar	DC bar	°C	°C										
1/4"	7	1250	2.5	10	10	-10	50	NBR	547N03	-	-	-	-	-	-	-	8059



For this page	Port size	Orifice (mm)	Qn (l/min)	MOPD (bar)	Fluid Temp (°C)
From	1/4"	7	1250	10	-10
To	1/2"	12	3000	10	50

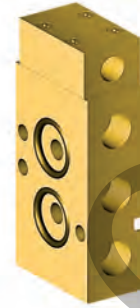
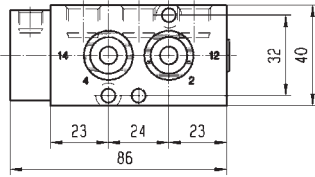

Drawing 8064

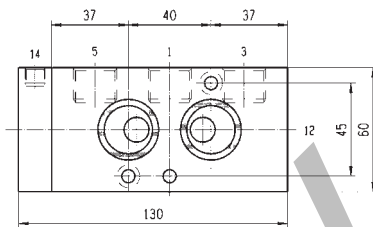
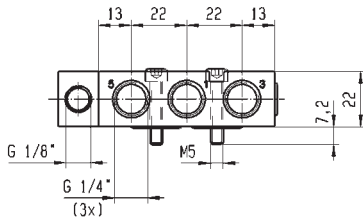

Drawing 8066

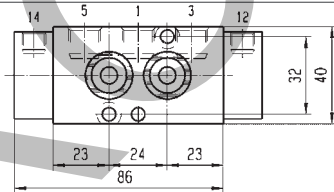
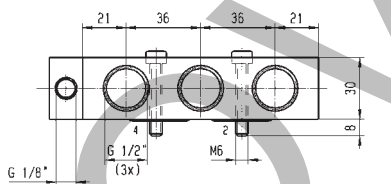

Drawing 8059

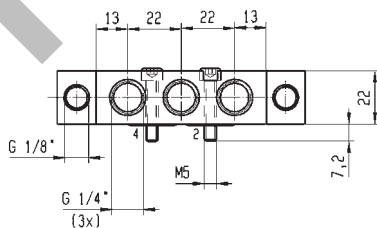

5/3

3 & 5 WAY PNEUMATIC VALVES FOR ACTUATOR CONTROL (NAMUR) EXTERNALLY OPERATED

ANODIZED ALUMINIUM

NAMUR

W1 CLOSED CENTER POSITION

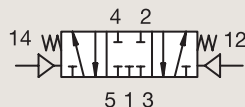

Port size	Orifice Ø	Flow factor	Operating Pressure Differential			Fluid Temp.		Seat Seal	Valve Ref.	Housing Ref.	Coil Ref.	ATEX Zone	Protection Mode	Power		Coil Group	Dwg. No.
			Min	Max (MOPD)	DC bar	Min	Max							AC W	DC W		
BSP	mm	Qn l/min	bar	AC bar	DC bar	°C	°C										
1/4"	7	1250	2.5	10	10	-10	50	NBR	542N03	-	-	-	-	-	-	-	8059

KONVANT



For this page	Port size	Orifice (mm)	Qn (l/min)	MOPD (bar)	Fluid Temp (°C)
From	1/4"	7	1250	10	-10
To	1/4"	7	1250	10	50

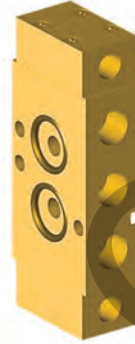
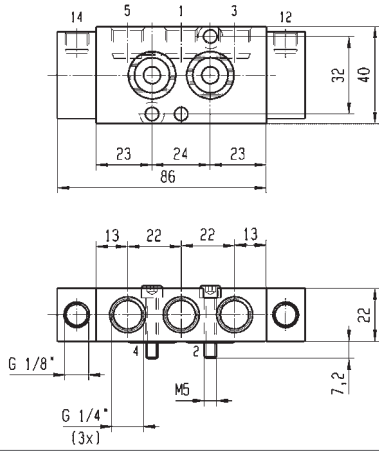

Drawing 8059

KOOLVARI.COM

3 & 5 WAY PNEUMATIC DISTRIBUTORS FOR ACTUATION CONTROL



316L STAINLESS STEEL 3 & 5 WAY VALVES FOR ACTUATOR CONTROL (PIPE MOUNTING AND NAMUR)



3/2
5/2

Actuation	Body	Function	Port Size	Orifice (mm)	Qn (l/min)	MOPD (bar)	Max Fluid Temp. (°C)	Page Parker Valves
Direct Operated	316L Stainless St./Pipe mounting	Universal	1/4"	2 to 6	680	12	75	350
			3/8"	6	680	10	75	358
	316L Stainless St./Sub-base mounting	Normally Closed	5 mm	2.5	220	12	14	360
		Universal	1/4"	6	680	10	65	360
Pilot Operated	316L Stainless St./NAMUR	Normally Closed	3/8"	6	680	10	75	362
	316L Stainless St./Pipe mounting	Normally Closed	3/8"	8	1400	10	80	364
		316L Stainless St./Pipe mounting/Spool	Normally Closed	3/8"	8	1400	10	80
	316L Stainless St./NAMUR/Spool	Dual Solenoids	3/8"	8	1400	10	80	368
		Normally Closed	3/8"-1/4"	8	1400	10	80	370
		Solenoid operated - spring return	3/8"-1/4"	8	1400	10	80	372
		Dual Solenoids	3/8"-1/4"	8	1400	10	80	374
Manual Reset	316L Stainless St./Pipe mounting	Universal	1/4"	6	680	10	65	376
			3/8"	6	680	10	65	382

3/2

3 WAY VALVES DIRECT OPERATED

V SERIES - STAINLESS STEEL VALVES FOR PIPE MOUNTING

316L STAINLESS ST.

PIPE MOUNTING

UNIVERSAL

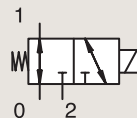

Port size	Orifice Ø	Flow factor			Operating Pressure Differential			Fluid Temp.		Seat Seal	Valve Ref.	Housing Ref.	Coil Ref.	ATEX Zone	Protection Mode	Power		Coil Group	Dwg. No.
		Kv	KV	Qn	Min	Max(MOPD)	Min	Max	AC W							DC W			
		l/min	m ³ /h	l/min	bar	AC bar	DC bar	°C									°C		
1/4" NPT	2	2.5	0.15	140	0	-	12	-25	65	FKM	U133V5595	-	496565	0-20	Ex ia IIC T4 to T6	-	0.3	9.0/10.1	8024
	2	2.5	0.15	140	0	12	12	-25	65	FKM	U133V5595	-	492310	1-21	Ex mb II T4 to T5	6	6	9.0/10.1	6713
	2	2.5	0.15	140	0	12	12	-25	65	FKM	U133V5595	-	496800	1-21	Ex db mb IIC T4	8	8	9.0/10.1	8024
	2	2.5	0.15	140	0	12	12	-25	65	FKM	U133V5595	-	496560	1-21	Ex db mb IIC T4	8	8	9.0/10.1	8024
	2	2.5	0.15	140	0	12	12	-25	50	FKM	U133V5595	-	496895	-	-	8	8	9.0/10.1	8024
	2	2.5	0.15	140	0	-	12	-25	65	FKM	U133V7595	-	496565	0-20	Ex ia IIC T4 to T6	-	0.3	9.0/10.1/10.3	8166
	2	2.5	0.15	140	0	12	12	-25	65	FKM	U133V7595	-	496800	1-21	Ex db mb IIC T4	8	8	9.0/10.1/10.3	8166
	2	2.5	0.15	140	0	12	12	-25	65	FKM	U133V7595	-	497105	1-21	Ex db IIC T4 to T6	8	8	9.0/10.1/10.3	8299
	2	2.5	0.15	140	0	12	12	-25	50	FKM	U133V7595	-	496895	-	-	8	8	9.0/10.1/10.3	8166
	2.5	3.5	0.21	220	0	-	8.5	-25	65	FKM	U133V5695	-	496565	0-20	Ex ia IIC T4 to T6	-	0.3	9.0/10.1	8024
	2.5	3.5	0.21	220	0	8.5	8.5	-25	75	FKM	U133V5695	-	492310	1-21	Ex mb II T4 to T5	6	6	9.0/10.1	6713
	2.5	3.5	0.21	220	0	8.5	8.5	-25	65	FKM	U133V5695	-	496800	1-21	Ex db mb IIC T4	8	8	9.0/10.1	8024
	2.5	3.5	0.21	220	0	8.5	8.5	-25	65	FKM	U133V5695	-	496560	1-21	Ex db mb IIC T4	8	8	9.0/10.1	8024
	2.5	3.5	0.21	220	0	8.5	8.5	-25	50	FKM	U133V5695	-	496895	-	-	8	8	9.0/10.1	8024
	2.5	3.5	0.21	220	0	-	8.5	-25	65	FKM	U133V7695	-	496565	0-20	Ex ia IIC T4 to T6	-	0.3	9.0/10.1/10.3	8166
	2.5	3.5	0.21	220	0	8.5	8.5	-25	65	FKM	U133V7695	-	496800	1-21	Ex db mb IIC T4	8	8	9.0/10.1/10.3	8166
	2.5	3.5	0.21	220	0	8.5	8.5	-25	65	FKM	U133V7695	-	497105	1-21	Ex db IIC T4 to T6	8	8	9.0/10.1/10.3	8299
	2.5	3.5	0.21	220	0	8.5	8.5	-25	50	FKM	U133V7695	-	496895	-	-	8	8	9.0/10.1/10.3	8166

Notes:

1. Valve delivered with an individual material traceability certificate (2.2 following EN10204)

IECEx
certified



UK
CA



For this page	Port size	Orifice (mm)	Qn (l/min)	MOPD (bar)	Fluid Temp (°C)
From	1/4"	2	140	8.5	-25
To	1/4"	2.5	220	12	75

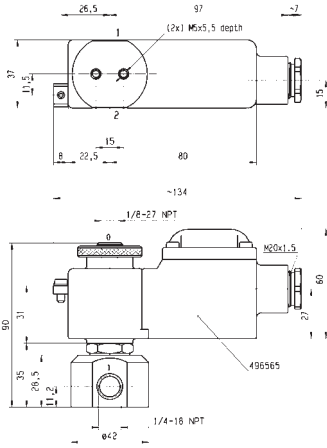

Drawing 8024

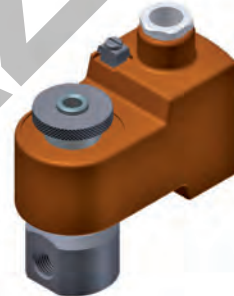
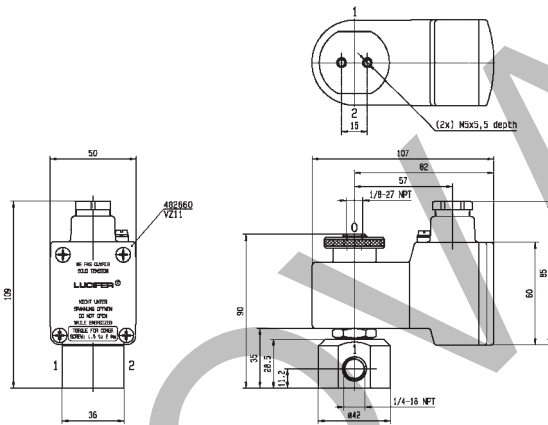

Drawing 6713

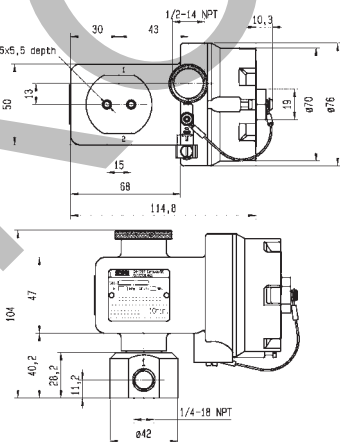

Drawing 8299

3/2

316L STAINLESS STEEL 3 & 5 WAY VALVES FOR ACTUATOR CONTROL (PIPE MOUNTING AND NAMUR) DIRECT OPERATED

316L STAINLESS ST.
PIPE MOUNTING

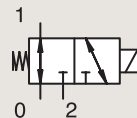

UNIVERSAL

Port size	Orifice Ø 1	Flow factor Qn l/min	Operating Pressure Differential			Fluid Temp.		Seat Seal	Valve Ref.	Housing Ref.	Coil Ref.	ATEX Zone	Protection Mode	Power		Coil Group	Dwg. No.
			Min	Max (MOPD)	DC	Min	Max							AC W	DC W		
1/4" NPTF	6	680	0	12	12	-25	65	NBR	U133X5156 ₂₄	-	492965.01	0-20	Ex ia IIC T6	-	0.3 to 3	9.0/10.1/10.2	7770
	6	680	0	12	12	-25	65	NBR	U133X5156 ₂₄	-	496700	1-21	Ex d mb IIC T4 to T6	6	6	9.0/10.1/10.2	7770
	6	680	0	12	12	-25	65	NBR	U133X5196 ₂	-	492210	1-21	Ex e mb II T3 to T6	-	1.8	9.0/10.1/10.2	6904
	6	680	0	12	12	-25	65	NBR	U133X5196 ₂	-	492965.01	0-20	Ex ia IIC T6	-	0.3 to 3	9.0/10.1/10.2	6904
	6	680	0	12	12	-25	65	NBR	U133X5196 ₂	-	496700	1-21	Ex d mb IIC T4 to T6	6	6	9.0/10.1/10.2	6904

Notes:

- 1.DC voltage only (or coil with rectifier). Minimum drop off voltage is 15% of nominal voltage (former DIN 19251)
- 2.Valve delivered with an individual material traceability certificate (2.2 following EN10204)
- 3.Valve only compatible with hydraulic oil and air/neutral gases
- 4.With manual override

3/2

316L STAINLESS STEEL 3 & 5 WAY VALVES FOR ACTUATOR CONTROL (PIPE MOUNTING AND NAMUR) DIRECT OPERATED

316L STAINLESS ST. PIPE MOUNTING

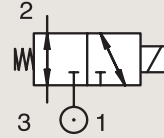

UNIVERSAL

Port size	Orifice Ø	Flow factor	Operating Pressure Differential			Fluid Temp.		Seat Seal	Valve Ref.	Housing Ref.	Coil Ref.	ATEX Zone	Protection Mode	Power		Coil Group	Dwg. No.
			Min	Max(MOPD)	DC bar	Min	Max							AC W	DC W		
1/4" NPTF	6	680	0	12	12	-40	65	VMQ	U133X7759 ₁₋₂	-	496895	-	-	8	8	9.0/10.1/10.2/10.3	8544
	6	680	0	-	12	-40	65	VMQ	U133X7759 ₁₋₂	-	496565	0-20	Ex ia IIC T4 to T6	-	0.3	9.0/10.1/10.2/10.3	8539
	6	680	0	12	12	-40	65	VMQ	U133X7759 ₁₋₂	-	497105	1-21	Ex db IIC T4 to T6	8	8	9.0/10.1/10.2/10.3	8537
	6	680	0	12	12	-40	65	VMQ	U133X7759 ₁₋₂	-	496700	1-21	Ex db mb IIC T4 to T6	6	6	9.0/10.1/10.2/10.3	8545
	6	680	0	12	12	-40	65	VMQ	U133X7759 ₁₋₂	-	492310	1-21	Ex mb II T4 to T5	9	8	9.0/10.1/10.2/10.3	8546
	6	680	0	-	12	-40	65	VMQ	U133X7759 ₁₋₂	-	492210	1-21	Ex eb mb IIC T5 to T6	-	1.8	9.0/10.1/10.2/10.3	8546
	6	680	0	12	12	-40	65	VMQ	U133X7709 ₁	-	496895	-	-	8	8	9.0/10.1/10.2/10.3	8551
	6	680	0	-	12	-40	65	VMQ	U133X7709 ₁	-	496565	0-20	Ex ia IIC T4 to T6	-	0.3	9.0/10.1/10.2/10.3	8550
	6	680	0	12	12	-40	65	VMQ	U133X7709 ₁	-	497105	1-21	Ex db IIC T4 to T6	8	8	9.0/10.1/10.2/10.3	8538
	6	680	0	12	12	-40	65	VMQ	U133X7709 ₁	-	496700	1-21	Ex db mb IIC T4 to T6	6	6	9.0/10.1/10.2/10.3	8549
	6	680	0	12	12	-40	65	VMQ	U133X7709 ₁	-	492310	1-21	Ex mb II T4 to T5	9	8	9.0/10.1/10.2/10.3	8548
	6	680	0	-	12	-40	65	VMQ	U133X7709 ₁	-	492210	1-21	Ex eb mb IIC T5 to T6	-	1.8	9.0/10.1/10.2/10.3	8548

Notes:

1. Valve delivered with an individual material traceability certificate (2.2 following EN10204)
2. With manual override

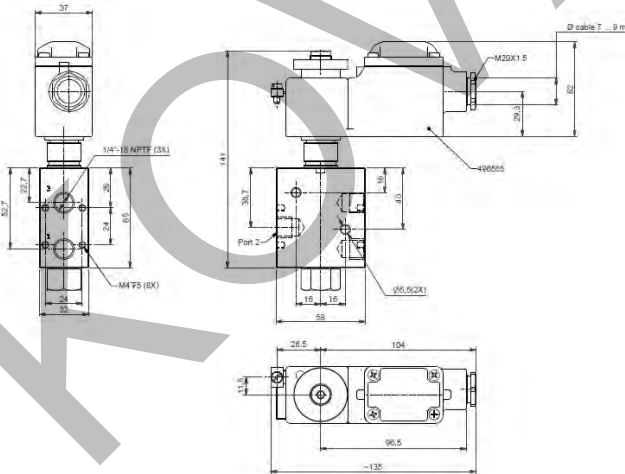

Drawing 8539

IECEx
certified



For this page	Port size	Orifice (mm)	Qn (l/min)	MOPD (bar)	Fluid Temp (°C)
From	1/4"	6	680	12	-25
To	1/4"	6	680	12	65

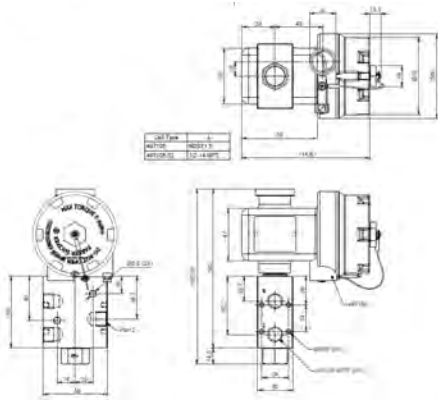

Drawing 8537

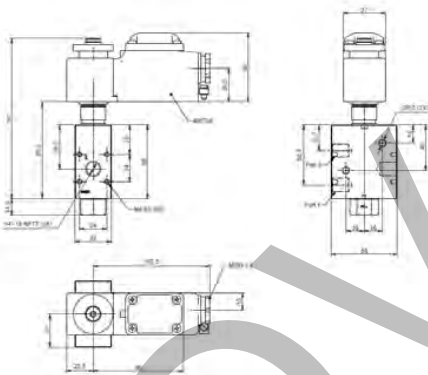

Drawing 8545

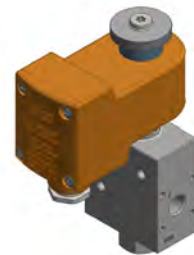
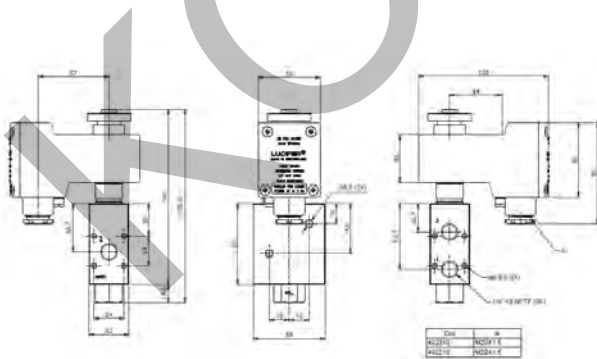

Drawing 8546

3/2

316L STAINLESS STEEL 3 & 5 WAY VALVES FOR ACTUATOR CONTROL (PIPE MOUNTING AND NAMUR)

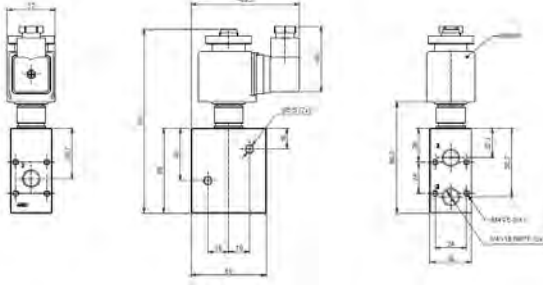

Drawing 8551

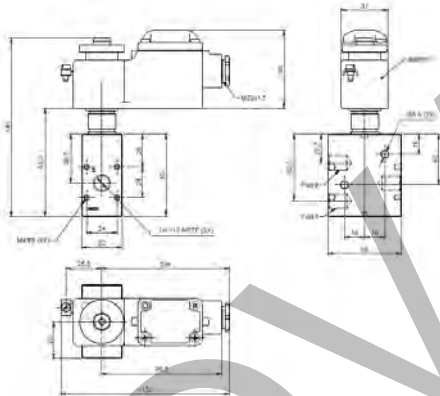

Drawing 8550

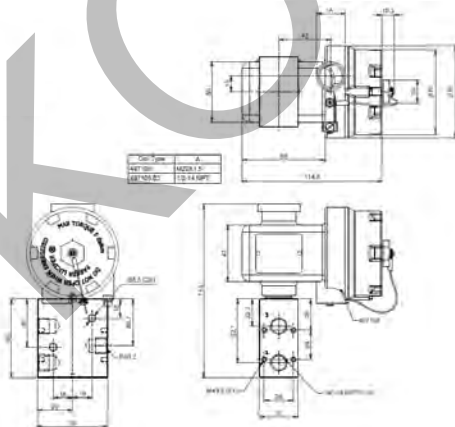

Drawing 8538

3/2

316L STAINLESS STEEL 3 & 5 WAY VALVES FOR ACTUATOR CONTROL (PIPE MOUNTING AND NAMUR) DIRECT OPERATED

316L STAINLESS ST. PIPE MOUNTING

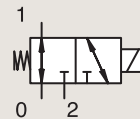

UNIVERSAL

Port size	Orifice Ø 1	Flow factor Qn l/min	Operating Pressure Differential		Fluid Temp.		Seat Seal	Valve Ref.	Housing Ref.	Coil Ref.	ATEX Zone	Protection Mode	Power		Coil Group	Dwg. No.	
			Min	Max (MOPD)	Min	Max							AC W	DC W			
			bar	AC bar DC bar	°C	°C											
3/8" NPTF	6	680	0	12	12	-25	75	NBR	U133X5296	-	492310	1-21	Ex e mb II T3 to T6	6	6	9.0/10.1/10.2	7669
	6	680	0	12	12	-25	65	NBR	U133X5296	-	492965.01	0-20	Ex ia IIC T6	-	0.3 to 3	9.0/10.1/10.2	7669
	6	680	0	12	12	-25	65	NBR	U133X5296	-	496700	1-21	Ex d mb IIC T4 to T6	6	6	9.0/10.1/10.2	7669

Notes:

1. Valve delivered with an individual material traceability certificate (2.2 following EN10204)

IECEx
certified



UK
CA



For this page	Port size	Orifice (mm)	Qn (l/min)	MOPD (bar)	Fluid Temp (°C)
From	3/8"	6	680	10	-25
To	3/8"	6	680	10	75

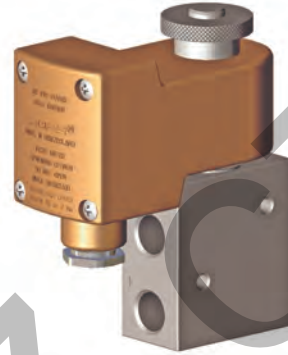
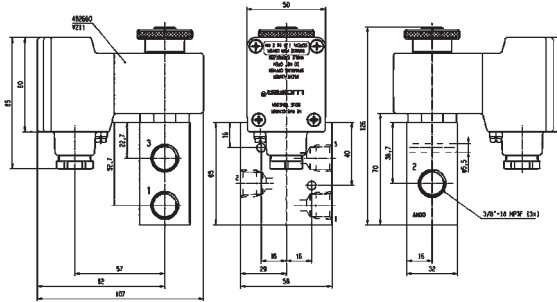

Drawing 7669

KOVAR

3/2

316L STAINLESS STEEL 3 & 5 WAY VALVES FOR ACTUATOR CONTROL (PIPE MOUNTING AND NAMUR) DIRECT OPERATED

316L STAINLESS ST.

SUB-BASE MOUNTING

NORMALLY CLOSED

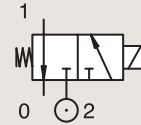

Port size	Orifice Ø mm	Flow factor			Operating Pressure Differential		Fluid Temp.		Seat Seal	Valve Ref.	Housing Ref.	Coil Ref.	ATEX Zone	Protection Mode	Power		Coil Group	Dwg. No.	
		Kv l/min	KV m³/h	Qn l/min	Min bar	Max (MOPD) DC bar	Min °C	Max °C							AC W	DC W			
SB	2.5	3.5	0.21	220	0	-	12	-25	75	FKM	U131F5295	-	496565	0-20	Ex ia IIC T4 to T6	-	0.3	9.0/10.1/10.2	8174
	2.5	3.5	0.21	220	0	12	12	-25	65	FKM	U131F5295	-	496800	1-21	Ex db mb IIC T4	8	8	9.0/10.1/10.2	8174
	2.5	3.5	0.21	220	0	12	12	-25	65	FKM	U131F5295	-	496560	1-21	Ex db mb IIC T4	8	8	9.0/10.1/10.2	8174
	2.5	3.5	0.21	220	0	-	12	-25	75	FKM	U131F5295	-	492210	1-21	Ex eb mb IIC T5 to T6	-	1 to 1.8	9.0/10.1/10.2	8343
	2.5	3.5	0.21	220	0	12	12	-25	75	FKM	U131F5295	-	492310	1-21	Ex mb II T4 to T5	6	6	9.0/10.1/10.2	8343
	2.5	3.5	0.21	220	0	12	12	-25	50	FKM	U131F5295	-	496895	-	-	8	8	9.0/10.1/10.2	8174
	2.5	3.5	0.21	220	0	-	12	-25	50	FKM	U131F7695	-	496565	0-20	Ex ia IIC T4 to T6	-	0.3	9.0/10.1/10.2/10.3	8174
	2.5	3.5	0.21	220	0	12	12	-25	75	FKM	U131F7695	-	497105	1-21	Ex db IIC T4 to T6	8	8	9.0/10.1/10.2/10.3	8302
	2.5	3.5	0.21	220	0	12	12	-25	65	FKM	U131F7695	-	496800	1-21	Ex db mb IIC T4	8	8	9.0/10.1/10.2/10.3	8174
	2.5	3.5	0.21	220	0	12	12	-25	50	FKM	U131F7695	-	496895	-	-	8	8	9.0/10.1/10.2/10.3	8174

Notes:

1. Valve only compatible with air and neutral gases

316L STAINLESS ST.

SUB-BASE MOUNTING

UNIVERSAL

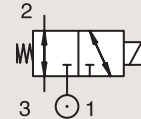

Port size	Orifice Ø mm	Flow factor			Operating Pressure Differential		Fluid Temp.		Seat Seal	Valve Ref.	Housing Ref.	Coil Ref.	ATEX Zone	Protection Mode	Power		Coil Group	Dwg. No.
		1 Qn l/min	Min bar	Max (MOPD) AC bar	DC bar	Min °C	Max °C	AC W							DC W			
1/4" NPTF	6	680	0	12	12	-25	65	FKM	U133X5195	-	492310	1-21	Ex e mb II T3 to T6	6	6	9.0/10.1/10.2	3572	
	6	680	0	12	12	-25	65	FKM	U133X5195	-	496700	1-21	Ex d mb IIC T4 to T6	6	6	9.0/10.1/10.2	3572	

Notes:

1. Valve delivered with an individual material traceability certificate (2.2 following EN10204)

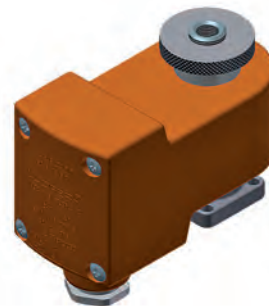
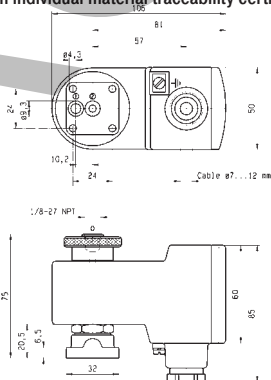

Drawing 8343

3/2

316L STAINLESS STEEL 3 & 5 WAY VALVES FOR ACTUATOR CONTROL (PIPE MOUNTING AND NAMUR) DIRECT OPERATED

316L STAINLESS ST. SUB-BASE MOUNTING

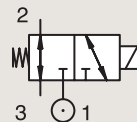

UNIVERSAL

Port size	Orifice Ø 1	Flow factor Qn l/min	Operating Pressure Differential			Fluid Temp.		Seat Seal	Valve Ref.	Housing Ref.	Coil Ref.	ATEX Zone	Protection Mode	Power		Coil Group	Dwg. No.
			Min	Max (MOPD)		Min	Max							AC W	DC W		
			bar	AC bar	DC bar	°C	°C										
1/4" NPTF	6	680	0	12	12	-25	65	FKM	U133X7195	-	492210	1-21	Ex e mb II T3 to T6	-	1.8	9.0/10.1/10.2	8172
	6	680	0	12	12	-25	65	FKM	U133X7195	-	492965.01	0-20	Ex ia IIC T6	-	0.3 to 3	9.0/10.1/10.2	8172
	6	680	0	12	12	-25	65	FKM	U133X7195	-	496700	1-21	Ex d mb IIC T4 to T6	6	6	9.0/10.1/10.2	8172

316L STAINLESS ST. NAMUR

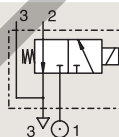

NORMALLY CLOSED

Port size	Orifice Ø 1	Flow factor Qn l/min	Operating Pressure Differential			Fluid Temp.		Seat Seal	Valve Ref.	Housing Ref.	Coil Ref.	ATEX Zone	Protection Mode	Power		Coil Group	Dwg. No.
			Min	Max (MOPD)		Min	Max							AC W	DC W		
			bar	AC bar	DC bar	°C	°C										
3/8" NPT	6	680	0	12	12	-25	65	NBR	U131X1201 ₁	-	492310	1-21	Ex e mb II T3 to T6	6	6	9.0/10.1/10.2	7668
	6	680	0	12	12	-25	75	NBR	U131X1201 ₁	-	492965.01	0-20	Ex ia IIC T6	-	0.3 to 3	9.0/10.1/10.2	7668
	6	680	0	12	12	-25	65	NBR	U131X1201 ₁	-	496700	1-21	Ex d mb IIC T4 to T6	6	6	9.0/10.1/10.2	7668

Notes:

1. Valve delivered with an individual material traceability certificate (2.2 following EN10204)

5/2

316L STAINLESS STEEL 3 & 5 WAY VALVES FOR ACTUATOR CONTROL (PIPE MOUNTING AND NAMUR) PILOT OPERATED



Process

316L STAINLESS ST. PIPE MOUNTING

NORMALLY CLOSED

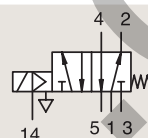

Port size	Orifice Ø 1 mm	Flow factor Qn l/min	Operating Pressure Differential		Fluid Temp.		Seat Seal	Valve Ref.	Housing Ref.	Coil Ref.	ATEX Zone	Protection Mode	Power		Coil Group	Dwg. No.
			Min bar	Max (MOPD) AC bar DC bar	Min °C	Max °C							AC W	DC W		
3/8" NPT	8	1400	2	10 10	-25	80	NBR	U441P3250 ₁₂	4270	481000	-	-	8	8	2.1	7565
	8	1400	2	10 10	-25	80	NBR	U441P3250 ₁₂	2995	481865	-	-	8	9	2.1	7565

Notes:

1. Pilot seat in FKM
2. Valve with external pilot pressure minimum 4 bar

316L STAINLESS ST. PIPE MOUNTING

NORMALLY CLOSED

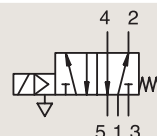

Port size	Orifice Ø 1 mm	Flow factor Qn l/min	Operating Pressure Differential		Fluid Temp.		Seat Seal	Valve Ref.	Housing Ref.	Coil Ref.	ATEX Zone	Protection Mode	Power		Coil Group	Dwg. No.
			Min bar	Max (MOPD) AC bar DC bar	Min °C	Max °C							AC W	DC W		
3/8"	8	1400	2	10 10	-25	80	NBR	U341P0250 ₁₂₃	8993	481045	-	-	2	2.5	1.1	7578
1/4" NPT	8	1400	2	10 10	-25	80	NBR	U341P0250 ₁₂₃	-	482606	1-21	Ex mb IIC T4/T5	2	2.5	1.1	7578
	8	1400	2	10 10	-25	80	NBR	U341P3250 ₁	4270	481000	-	-	8	8	2.1	7558
1/4" NPT	8	1400	2	10 10	-25	80	NBR	U341P3250 ₁	2995	481865	-	-	8	9	2.1	7558
	8	1400	2	10 10	-25	80	NBR	U341P3250 ₁	2995	492453	-	-	8	9	2.1	7558

Notes:

1. Pilot seat in FKM
2. With captured exhaust
3. With manual override



For this page	Port size	Orifice (mm)	Qn (l/min)	MOPD (bar)	Fluid Temp (°C)
From	3/8"	8	1400	10	-25
To	3/8"	8	1400	10	80

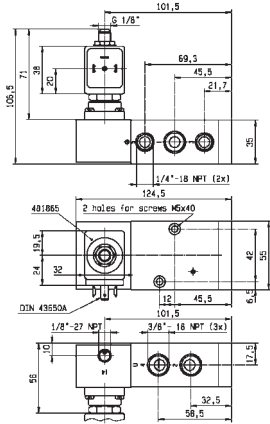

Drawing 7565

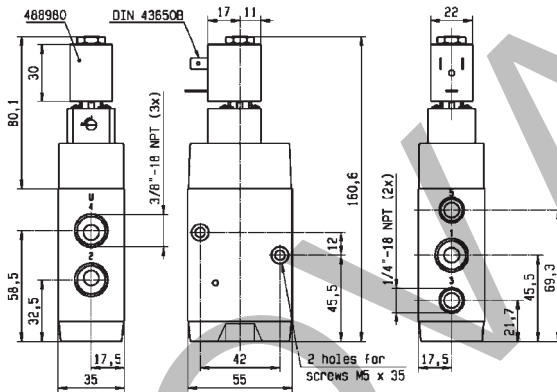

Drawing 7578

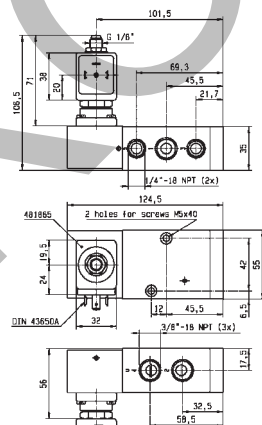

Drawing 7558

5/2

316L STAINLESS STEEL 3 & 5 WAY VALVES FOR ACTUATOR CONTROL (PIPE MOUNTING AND NAMUR) PILOT OPERATED

316L STAINLESS ST.
PIPE MOUNTING

NORMALLY CLOSED

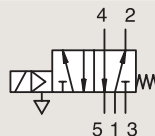

Port size	Orifice Ø 1	Flow factor Qn l/min	Operating Pressure Differential		Fluid Temp.		Seat Seal	Valve Ref.	Housing Ref.	Coil Ref.	ATEX Zone	Protection Mode	Power		Coil Group	Dwg. No.
			Min	Max (MOPD) AC bar DC bar	Min	Max							AC W	DC W		
3/8" NPT	8	1400	2	- 10	-25	55	NBR	U341P3292 ₁	2995	483580.01	0-20	Ex ia IIC T6	-	0.5 to 3	7.0	7560
	8	1400	2	10 10	-25	75	NBR	U341P3295 ₁	-	492310	1-21	Ex e mb II T3 to T6	6	6	9.0/10.1	7561
	8	1400	2	- 10	-25	75	NBR	U341P3295 ₁	-	492965.01	0-20	Ex ia IIC T6	-	0.3 to 3	9.0/10.1	7561

KONVARI

IECEX
certified



For this page	Port size	Orifice (mm)	Qn (l/min)	MOPD (bar)	Fluid Temp (°C)
From	3/8"	8	1400	10	-25
To	3/8"	8	1400	10	75

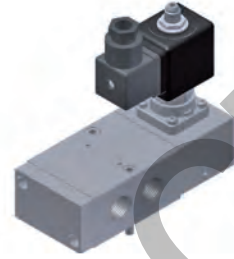
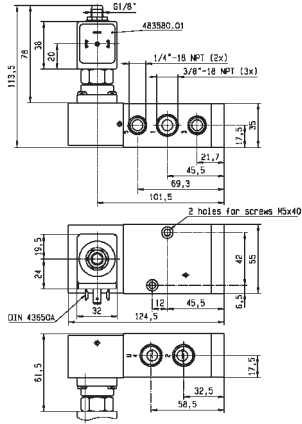

Drawing 7560

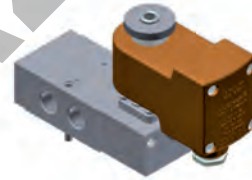
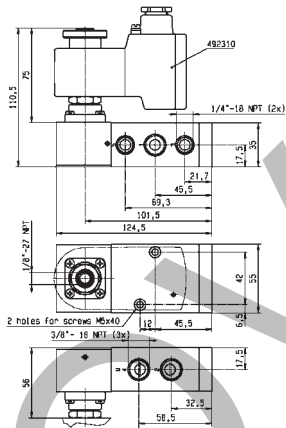

Drawing 7561

5/2

316L STAINLESS STEEL 3 & 5 WAY VALVES FOR ACTUATOR CONTROL (PIPE MOUNTING AND NAMUR) PILOT OPERATED

316L STAINLESS ST.
PIPE MOUNTING

DUAL SOLENOIDS

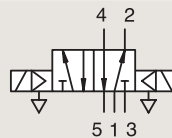

Port size	Orifice Ø 1 mm	Flow factor Qn l/min	Operating Pressure Differential			Fluid Temp.		Seat Seal	Valve Ref.	Housing Ref.	Coil Ref.	ATEX Zone	Protection Mode	Power		Coil Group	Dwg. No.
			Min	Max (MOPD) AC bar DC bar	Min	Max	°C							°C	AC W		
3/8" NPT	8	1400	2	10	10	-25	80	NBR	U347P3250	4270	481000	-	-	8	8	2.1	7563
	8	1400	2	10	10	-25	80	NBR	U347P3250	-	483371	1-21	Ex e mb IIC T4	8	8	2.1	7563
	8	1400	2	10	10	-25	75	NBR	U347P3295	-	492310	1-21	Ex e mb II T3 to T6	6	6	10.1	7564
	8	1400	2	10	10	-25	75	NBR	U347P3295	-	496800	1-21	Ex d mb IIC T4	8	8	10.1	7564

Notes:

1. Pilot seat in FKM

IECEx
certified



For this page	Port size	Orifice (mm)	Qn (l/min)	MOPD (bar)	Fluid Temp (°C)
From	3/8"	8	1400	10	-25
To	3/8"	8	1400	10	80

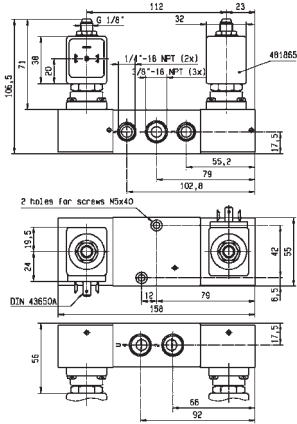

Drawing 7563

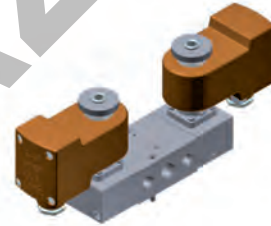
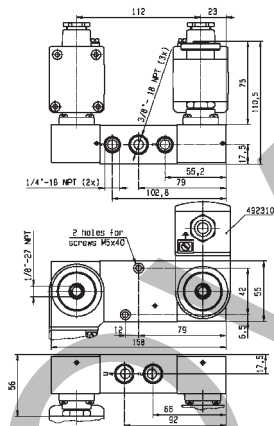

Drawing 7564

3/2-5/2

**316L STAINLESS STEEL 3 & 5 WAY VALVES
FOR ACTUATOR CONTROL (PIPE MOUNTING AND NAMUR)
PILOT OPERATED**

**316L STAINLESS ST.
NAMUR**

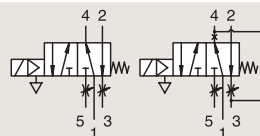

NORMALLY CLOSED

Port size	Orifice Ø 1 mm	Flow factor Qn l/min	Operating Pressure Differential			Fluid Temp.		Seat Seal	Valve Ref.	Housing Ref.	Coil Ref.	ATEX Zone	Protection Mode	Power		Coil Group	Dwg. No.
			Min bar	Max (MOPD) AC bar	DC bar	Min °C	Max °C							AC W	DC W		
3/8"- 1/4" NPT	8	1400	2	10	10	-25	80	NBR	U341N3250	2995	481865	-	-	8	9	2.1	7554
	8	1400	2	10	10	-25	80	NBR	U341N3250	-	492190	1-21	Ex e mb IIC T3/T4	11	9	2.1	7554
	8	1400	2	-	10	-25	55	NBR	U341N3292	2995	483580.01	0-20	Ex ia IIC T6	-	0.5	7.0	7556
	8	1400	2	10	10	-25	75	NBR	U341N3295	-	492310	1-21	Ex e mb II T3 to T6	6	6	10.1	7696
	8	1400	2	10	10	-25	75	NBR	U341N3295	-	496800	1-21	Ex d mb IIC T4	8	8	10.1	7696

Notes:

1. Pilot seat in FKM
2. With captured exhaust
3. With manual override

3 & 5 WAY PNEUMATIC DISTRIBUTORS



For this page	Port size	Orifice (mm)	Qn (l/min)	MOPD (bar)	Fluid Temp (°C)
From	3/8"-1/4"	8	1400	10	-25
To	3/8"-1/4"	8	1400	10	80

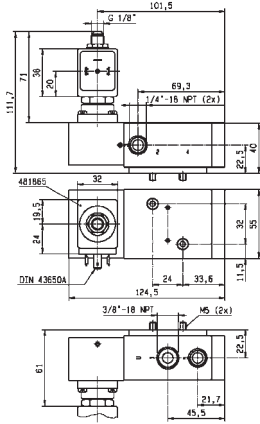

Drawing 7554

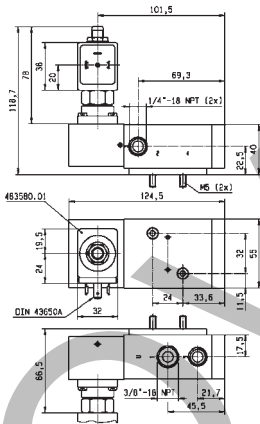

Drawing 7556

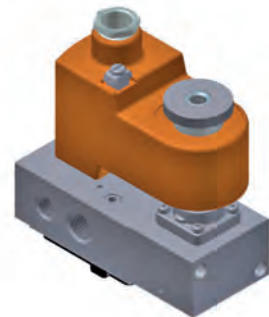
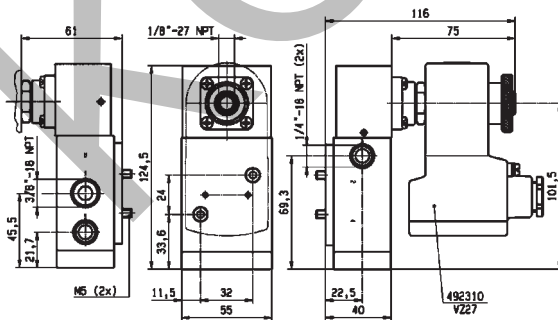

Drawing 7696

3/2-5/2

316L STAINLESS STEEL 3 & 5 WAY VALVES FOR ACTUATOR CONTROL (PIPE MOUNTING AND NAMUR) PILOT OPERATED

316L STAINLESS ST.

NAMUR

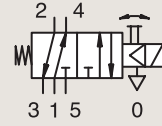

SOLENOID OPERATED - SPRING RETURN

Port size	Orifice Ø 1 mm	Flow factor Qn l/min	Operating Pressure Differential			Fluid Temp.		Seat Seal	Valve Ref.	Housing Ref.	Coil Ref.	ATEX Zone	Protection Mode	Power		Coil Group	Dwg. No.
			Min	Max (MOPD) AC bar	DC bar	Min °C	Max °C							AC W	DC W		
3/8"- 1/4" NPT	8	1400	2	10	10	-25	80	NBR	U341N0250 ₁₂₃	-	482606	1-21	Ex mb IIC T4/T5	2	2.5	1.1	7577
	8	1400	2	10	10	-25	80	NBR	U341N0250 ₁₂₃	8993	488980	-	-	2	2.5	1.1	7577

Notes:

- 1. Pilot seat in FKM
- 2. With captured exhaust
- 3. With manual override

KONVARI



For this page	Port size	Orifice (mm)	Qn (l/min)	MOPD (bar)	Fluid Temp (°C)
From	3/8"-1/4"	8	1400	10	-25
To	3/8"-1/4"	8	1400	10	80

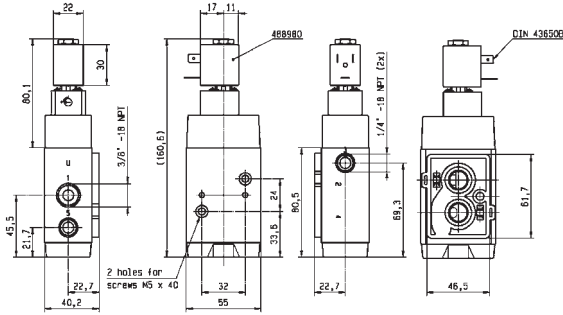

Drawing 7577

KOLVAR.COM

5/2

316L STAINLESS STEEL 3 & 5 WAY VALVES FOR ACTUATOR CONTROL (PIPE MOUNTING AND NAMUR) PILOT OPERATED

316L STAINLESS ST.
NAMUR

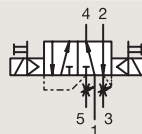

DUAL SOLENOIDS

Port size	Orifice Ø 1 mm	Flow factor Qn l/min	Operating Pressure Differential			Fluid Temp.		Seat Seal	Valve Ref.	Housing Ref.	Coil Ref.	ATEX Zone	Protection Mode	Power		Coil Group	Dwg. No.
			Min bar	Max (MOPD) AC bar	DC bar	Min °C	Max °C							AC W	DC W		
3/8"- 1/4" NPT	8	1400	2	10	10	-25	80	NBR	U347N3250	4270	481000	-	-	8	8	2.1	7557
	8	1400	2	10	10	-25	80	NBR	U347N3250	2995	481865	-	-	8	9	2.1	7557

Notes:

1. Pilot seat in FKM



For this page	Port size	Orifice (mm)	Qn (l/min)	MOPD (bar)	Fluid Temp (°C)
From	3/8"-1/4"	8	1400	10	-25
To	3/8"-1/4"	8	1400	10	80

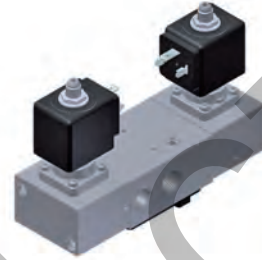
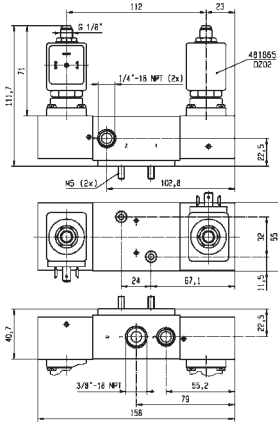

Drawing 7557

KOVAR

3/2

316L STAINLESS STEEL 3 & 5 WAY VALVES FOR ACTUATOR CONTROL (PIPE MOUNTING AND NAMUR) MANUAL RESET



Process

316L STAINLESS ST. PIPE MOUNTING

UNIVERSAL

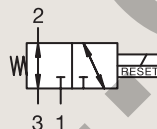

Port size	Orifice Ø	Flow factor	Operating Pressure Differential			Fluid Temp.		Seat Seal	Valve Ref.	Housing Ref.	Coil Ref.	ATEX Zone	Protection Mode	Power		Coil Group	Dwg. No.
			Min	Max (MOPD)	DC	Min	Max							AC W	DC W		
1/4" NPTF	6	680	0	-	10	-25	65	NBR	U033X5156 ₁	-	482870.01	0-20	Ex ia IIC T6	-	0.3 to 3	10.1/10.2/12.0	7771
	6	680	0	10	10	-25	65	NBR	U033X5156 ₁	-	492310	1-21	Ex e mb II T3 to T6	6	6	10.1/10.2/12.0	7771
	6	680	0	-	10	-25	65	NBR	U033X5156 ₁	-	492335	0-20	NEMA 4-4X	-	0.3 to 3	10.1/10.2/12.0	7771
	6	680	0	10	10	-25	65	NBR	U033X5156 ₁	-	496700	1-21	Ex d mb IIC T4 to T6	6	6	10.1/10.2/12.0	7771

Notes:

1. Valve delivered with an individual material traceability certificate (2.2 following EN10204)



For this page	Port size	Orifice (mm)	Qn (l/min)	MOPD (bar)	Fluid Temp (°C)
From	1/4"	6	680	10	-25
To	1/4"	6	680	10	65

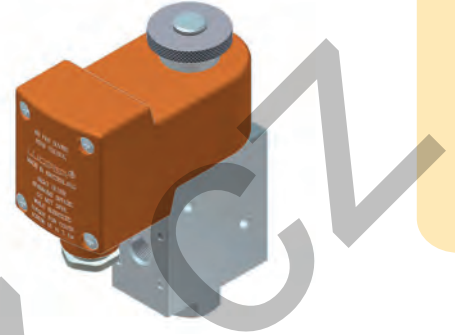
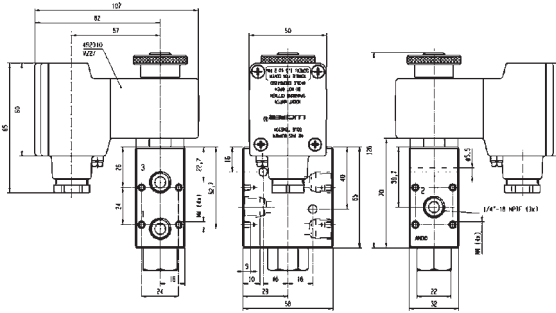

Drawing 7771

KONVARI

3/2

316L STAINLESS STEEL 3 & 5 WAY VALVES FOR ACTUATOR CONTROL (PIPE MOUNTING AND NAMUR) MANUAL RESET

316L STAINLESS ST.
PIPE MOUNTING

UNIVERSAL - MANUAL RESET

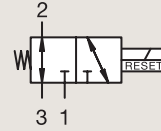

Port size	Orifice Ø 1	Flow factor Qn l/min	Operating Pressure Differential		Fluid Temp.		Seat Seal	Valve Ref.	Housing Ref.	Coil Ref.	ATEX Zone	Protection Mode	Power		Coil Group	Dwg. No.	
			Min	Max (MOPD)	Min	Max							AC	DC			
			bar	DC bar	°C	°C							W	W			
1/4" NPTF	6	680	0	12	12	-40	65	VMQ	U033X7759,	-	496895	-	-	8	8	-	8544
	6	680	0	12	12	-40	65	VMQ	U033X7759,	-	497105	1-21	Ex db IIC T4 to T6	8	8	-	8537
	6	680	0	12	12	-40	65	VMQ	U033X7759,	-	496700	1-21	Ex db mb IIC T4 to T6	6	6	-	8545
	6	680	0	12	12	-40	65	VMQ	U033X7759,	-	492310	1-21	Ex mb II T4 to T5	9	8	-	8546

Notes:

1. Valve delivered with an individual material traceability certificate (2.2 following EN10204)

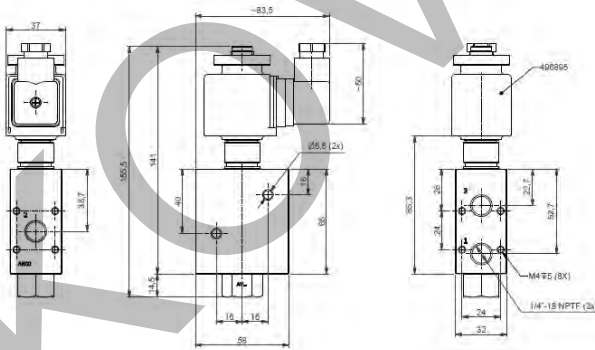

Drawing 8544



For this page	Port size	Orifice (mm)	Qn (l/min)	MOPD (bar)	Fluid Temp (°C)
From	1/4"	6	680	10	-40
To	1/4"	6	680	10	65

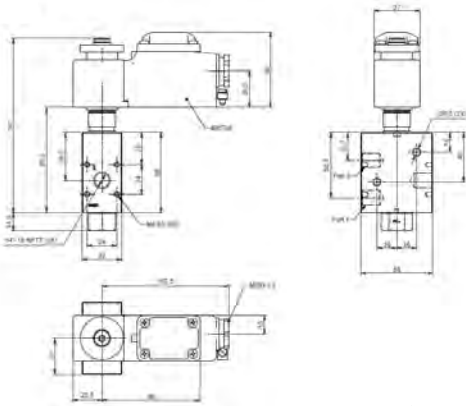

Drawing 8545

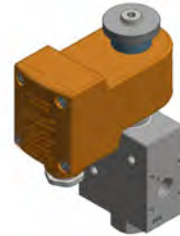
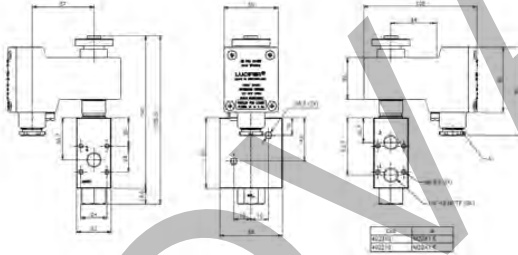

Drawing 8546

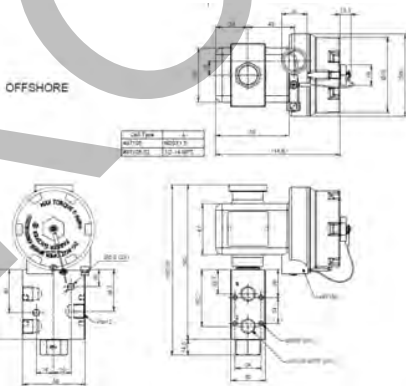

Drawing 8537

3/2

316L STAINLESS STEEL 3 & 5 WAY VALVES FOR ACTUATOR CONTROL (PIPE MOUNTING AND NAMUR) MANUAL RESET

316L STAINLESS ST.
PIPE MOUNTING

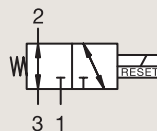

UNIVERSAL

Port size	Orifice Ø 1	Flow factor Qn l/min mm	Operating Pressure Differential			Fluid Temp.		Seat Seal	Valve Ref.	Housing Ref.	Coil Ref.	ATEX Zone	Protection Mode	Power		Coil Group	Dwg. No.
			Min	Max (MOPD)		Min	Max							AC W	DC W		
				bar	AC bar												
1/4" NPTF	6	560	0	12	12	-25	65	FKM	U033X5195 ₁	-	492310	1-21	Ex e mb II T3 to T6	6	6	10.1/10.2/12.0	3594
	6	560	0	12	12	-25	65	FKM	U033X5195 ₁	-	496700	1-21	Ex d mb IIC T4 to T6	6	6	10.1/10.2/12.0	3594

Notes:

1. Valve delivered with an individual material traceability certificate (2.2 following EN10204)



For this page	Port size	Orifice (mm)	Qn (l/min)	MOPD (bar)	Fluid Temp (°C)
From	1/4"	6	560	10	-25
To	1/4"	6	680	10	65

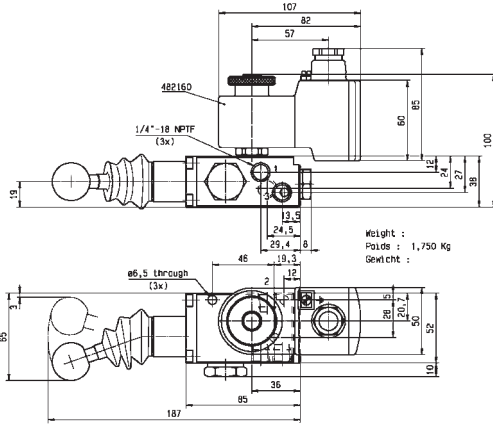

Drawing 3594

KONVAKI

3/2

316L STAINLESS STEEL 3 & 5 WAY VALVES FOR ACTUATOR CONTROL (PIPE MOUNTING AND NAMUR) MANUAL RESET

316L STAINLESS ST.
PIPE MOUNTING

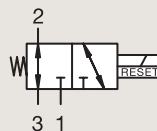

UNIVERSAL

Port size	Orifice Ø 1	Flow factor Qn l/min mm	Operating Pressure Differential			Fluid Temp.		Seat Seal	Valve Ref.	Housing Ref.	Coil Ref.	ATEX Zone	Protection Mode	Power		Coil Group	Dwg. No.
			Min	Max (MOPD)		Min	Max							AC W	DC W		
				bar	AC bar												
3/8" NPTF	6	680	0	-	10	-25	65	NBR	U033X5256	-	482870.01	0-20	Ex ia IIC T6	-	0.3 to 3	10.1/10.2/12.0	7671
	6	680	0	10	10	-25	65	NBR	U033X5256	-	492310	1-21	Ex e mb II T3 to T6	6	6	10.1/10.2/12.0	7671
	6	680	0	10	10	-25	65	NBR	U033X5256	-	496700	1-21	Ex d mb IIC T4 to T6	6	6	10.1/10.2/12.0	7671

Notes:

1. Valve delivered with an individual material traceability certificate (2.2 following EN10204)

IECEX
certified



UK
CA



For this page	Port size	Orifice (mm)	Qn (l/min)	MOPD (bar)	Fluid Temp (°C)
From	3/8"	6	680	10	-25
To	3/8"	6	680	10	65

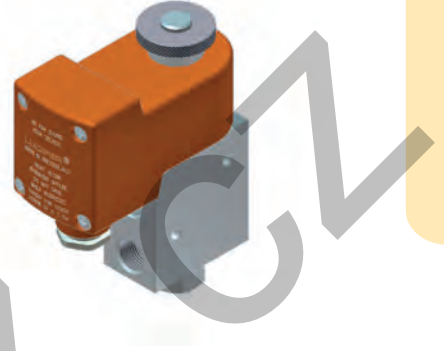
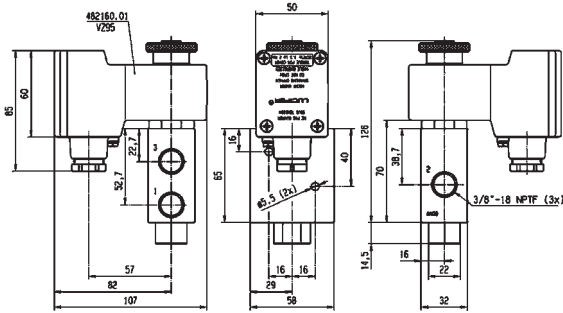

Drawing 7671

KOVLAR.COM

ELECTROPNEUMATIC PRESSURE REGULATORS



aerospace
 climate control
 electromechanical
 filtration
 fluid & gas handling
 hydraulics
 pneumatics
 process control
 sealing & shielding



Basic	1/4" 1/2"
Comfort	1/4" 1/2"
Comfort	1/2" HP 1" 2"
Comfort ATEX	1/2" 1" 2"



ELECTROPNEUMATIC PRESSURE REGULATORS

EPP4 Programmable Pressure Regulator

EPP4 is an electro pneumatic pressure regulator with integrated electronic system.

A pulsed width modulated solenoid valve controls the output pressure proportionally to an analog input signal.

Very high accuracy is guaranteed thanks to a high precision closed loop signal provided by a built in pressure sensor.

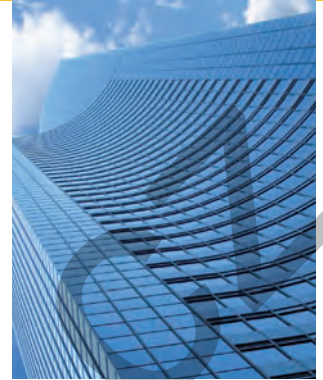

Market

Robotics
Paper industry
Machine tools
Mobile
Buildings
Textile
Instrumentation
Semi conductor



Description of Applications

Welding
Speed and brake control
Sanding
Cutting
Humidification
Tension regulation
Painting
Presses
Polishing
Adaptative suspension control



Value Propositions for the EPP4 Range of Proportional Pressure Regulators

- All parameters fully adjustable through the PC software Calys
- Easy to use software
- Long life expectancy
- Compact and light
- Limited inventory
- Low power
- Flexible remote display positioning
- Proven expertise of Parker, a pioneer in pressure regulation technology

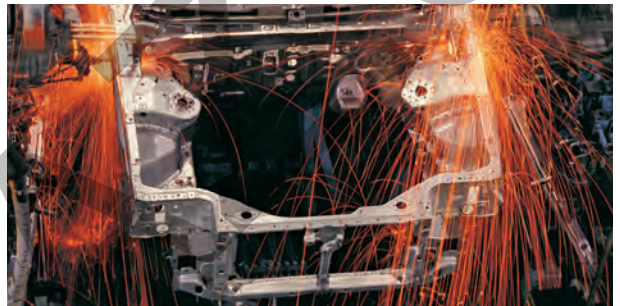

calys Software for EPP Comfort

Calys is a unique software in house developed to configurate all the parameters of the EPP4 Comfort range. Calys is an option of the EPP4. To use CALYS, you need to order cable reference 496449 wich permits the communication between the EPP4 and a PC.

Calys offers many capabilities:

- It enables distributors to reduce inventory by keeping a generic EPP4 in stock and adjust it to the needs of each customer application. They can switch for example from 0-10 V to 4-20 mA, or from 0-7 bar pressure range to 0-5 bar.
- Engineers designing a pneumatic system are able to monitor precisely all the important values (electrical or pneumatical) directly on their laptop.
- After sales technicians are able to receive via email all the parameters measured by the EPP4 installed on a machine wherever its location allowing remote ma intenance operation.
- PID regulation parameters can be adjusted with Calys to match required regulator response (like slow or reactive).

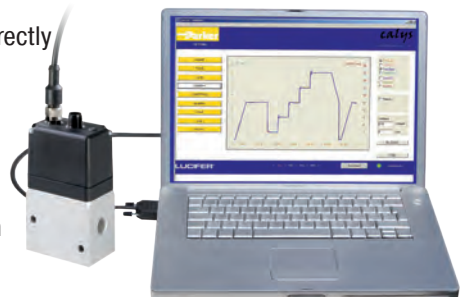

To download free Calys software click on www.parker.com

ELECTROPNEUMATIC PRESSURE REGULATORS

KOVLANZ.CZ

TABLE OF CONTENT

Introduction EPPpage 384

EPP4 Basic Rangepage 386

EPP4 Comfort Rangepage 390

EPP4 Comfort HP Rangepage 394

EPP4 Comfort Range ATEXpage 400

Accessoriespage 406



INTRODUCTION

Description Operation

The EPP4 Series is a family of electrically remote-controlled pneumatic pressure regulators with closed loop integrated electronic control.

It allows regulating the outlet pressure proportionally to an electrical control signal.

The EPP4 regulator comprises a traditional servo-operated pneumatic pressure regulator, where the pilot chamber is fed by one or the other of two pulse width modulated 2-way solenoid valves.

The pressure sensor measures the outlet pressure of the regulator and provides a feedback signal to the controller.

Any difference between the control signal and the feedback signal is converted to a digital signal to energise the coil of one or the other 2-way valves to correct the position of the regulator.

The control signal can be a voltage (0-10 V) or a current (4-20 mA). The inlet of the "Filling Valve" is connected directly to the main inlet P of the regulator;

when energised this valve will fill the servo-chamber for increasing the pressure at the outlet A of the regulator.

When the other "exhaust valve" is energised (reduction of pressure at the outlet A of the regulator), the pressure of the servo-chamber will be exhausted through a discharge orifice located between the cover and the body and directly fed to the atmosphere without silencer.

The exhaust of the main regulated pressure will be made through the quick exhaust R.

The use of a conventional silencer is recommended. Both solenoid valves assure the Filling or Emptying of the servo-chamber in order to increase or decrease the pressure at the outlet of the regulator.

In rest position of the valves all ports are blocked.

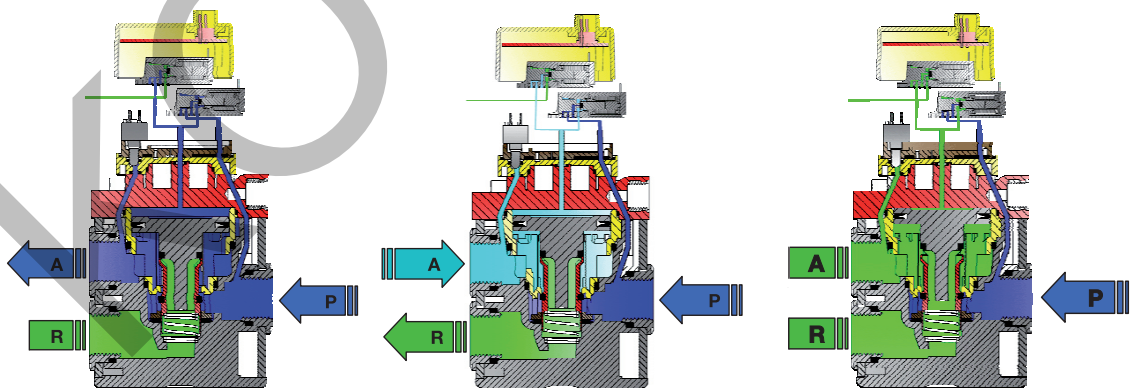

Filling position

Stand by position

Emptying position

Block Diagram

The controller receives both the control signal (set pressure) and the feedback signal from the sensor (outlet pressure).

Any difference between the two amplifier inputs results in a corresponding output which drives the appropriate 2-way pulse width modulated solenoid valve so that the pilot piston moves to correct the pressure.

The same feedback signal from the sensor is used for the output feedback in voltage and current.

The digital signal (alarm) is activated when the conditions (out of pressure or time tolerance) are met.

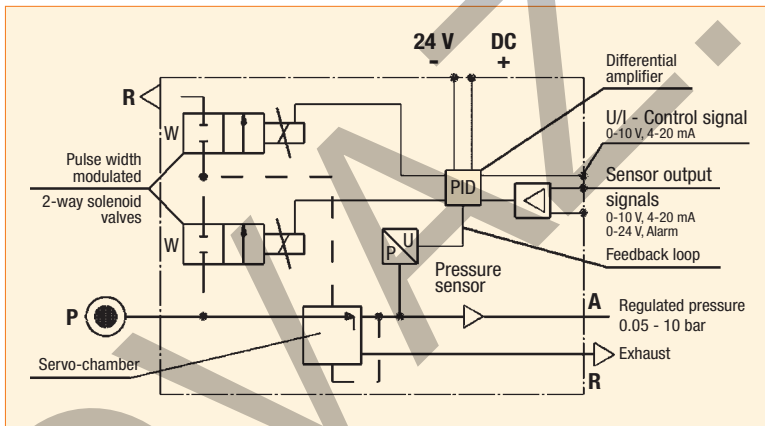

EPP4 possible executions : Basic and Comfort

EPP4 Basic and Comfort ranges share the same reliable mechanical parts. Proportional regulation is also identical for the two different executions, giving the same characteristics for hysteresis or precision for instance.

Comfort range regulators have a second M12 connector, that can be used to connect a remote display showing the current regulated pressure, or a PC to easily set the regulation's parameters. These are the key feature options for a comfortable use.

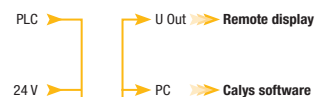

The B connector offers connection to the remote display or the PC.

EPP4 BASIC 1/4" & 1/2"

Basic	1/4" 1/2"
Comfort	1/4" 1/2"
Comfort	1/2" HP 1" 2"
Comfort ATEX	1/2" 1" 2"

TECHNICAL DATA

	Basic 1/4"	Basic 1/2"
Fluids:	Lubricated or non lubricated air and neutral gases Recommended filtration: 50 µm	
Temperature range:	Ambient: 0°C to +50°C Fluid: 0°C to +50°C	
Inlet pressure range: The inlet pressure must always be at least 1 bar above the regulated pressure.	1 to 12 bar	1 to 12 bar
Outlet pressure range:	0.05 to 10 bar	
Hysteresis:	± 50 mbar (factory set up)	
Air consumption at constant control signal:	0	
Supply voltage:	24 V DC ± 15% (Max. ripple 1 V)	
Power consumption:	Max. 2.8 W with 24 V DC and constant changes of the control signal < 1.5 W without change of control signal	
Control signal:	Analog 0 - 10 V Analog 4 - 20 mA	
Max. flow: Indicative response time: With a volume of 330 cm ³ at the outlet of the regulator	70 m ³ /h	150 m ³ /h
Filling 2 to 4 bar:	50 msec	60 msec
Filling 2 to 8 bar:	100 msec	120 msec
Emptying 4 to 2 bar:	70 msec	90 msec
Emptying 8 to 2 bar:	130 msec	190 msec
Safety position:	In case of control signal failure or if it is less than 50mV, the regulated pressure drops automatically to 0 bar (atmospheric pressure). In case of voltage supply failure, the regulated pressure will be kept constant.	
Electrical connection:	M12 - 4 pin; 4 x 0.34 mm ²	
Life expectancy:	> 50 Million changes of control signal steps	
Mounting position:	Indifferent (recommended position: upright; electronic part on top)	
Resistance to vibrations:	30 g in all directions	
Degree of protection:	IP 65	
Assembly:	Silicone free	
Electromagnetic compatibility: In accordance with:	EN 61000-6-1: 2001 EN 61000-6-2: 2001 EN 61000-6-3: 2001 EN 61000-6-4: 2001	
Installation and setting instructions:	See our "Notice 408038, 408014" and appendix supplied with the product.	

Note: Parker reserves the right to change specifications without notification.

EPP4 BASIC 1/4" & 1/2"

FLOW CURVES

Flow Curve Basic 1/4"

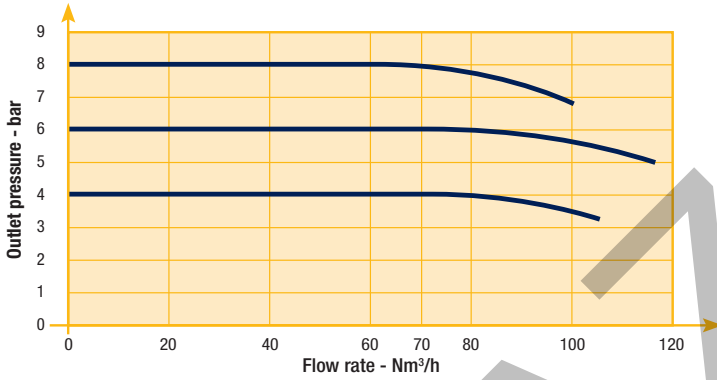

Flow Curve Basic 1/2"

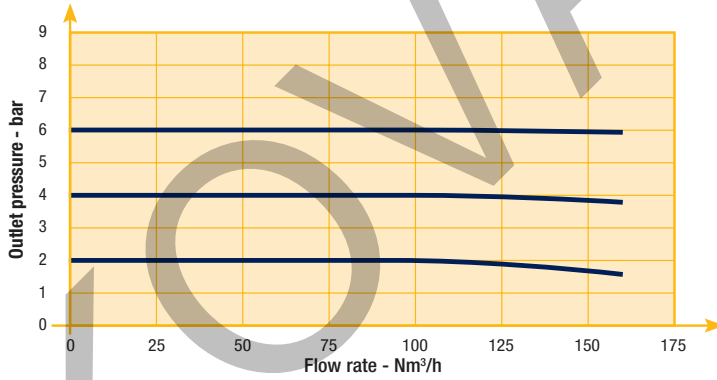

EPP4 BASIC 1/4" & 1/2"

REFERENCES

Codes	Pipe	Pressure Range (bar)	Control Signal (see options)	Drawing Number
P4BG2001A001	G 1/4"	0 - 4 bar	4 - 20 mA	1
P4BG2001A002	G 1/4"	0 - 10 bar	0 - 10 V	1
P4BG2001A003	G 1/4"	0 - 10 bar	4 - 20 mA	1
P4BG2001A004	G 1/4"	0 - 6 bar	0 - 10 V	1
P4BG2001A005	G 1/4"	0 - 6 bar	4 - 20 mA	1
P4BG2001A006	G 1/4"	0 - 5 bar	0 - 10 V	1
P4BG2001A007	G 1/4"	0 - 5 bar	4 - 20 mA	1
P4BG2001A008	G 1/4"	0 - 7 bar	0 - 10 V	1
P4BG2001A009	G 1/4"	0 - 7 bar	4 - 20 mA	1
P4BG2003A002 *	G 1/4"	0 - 10 bar	0 - 10 V	1
P4BG2003A003 *	G 1/4"	0 - 10 bar	4 - 20 mA	1
P4BG4001A002	G 1/2"	0 - 10 bar	0 - 10 V	2
P4BG4001A003	G 1/2"	0 - 10 bar	4 - 20 mA	2
P4BG4001A004	G 1/2"	0 - 6 bar	0 - 10 V	2
P4BG4001A005	G 1/2"	0 - 6 bar	4 - 20 mA	2
P4BG4001A006	G 1/2"	0 - 5 bar	0 - 10 V	2
P4BG4001A007	G 1/2"	0 - 5 bar	4 - 20 mA	2
P4BG4001A008	G 1/2"	0 - 7 bar	0 - 10 V	2
P4BG4001A009	G 1/2"	0 - 7 bar	4 - 20 mA	2
P4BG4004A010 ***	G 1/2"	0 - 4 bar	0 - 10 V	2
P4BG4051A002 **	G 1/2"	0 - 10 bar	4 - 20 mA	2
P4BN2001A002	NPT 1/4"	0 - 10 bar	0 - 10 V	2
P4BN2001A003	NPT 1/4"	0 - 10 bar	4 - 20 mA	2
P4BN4001A002	NPT 1/2"	0 - 10 bar	0 - 10 V	2
P4BN4001A003	NPT 1/2"	0 - 10 bar	4 - 20 mA	2

* Integrated pilot exhaust

** O2

*** External pressure supply



EPP4 BASIC 1/4" & 1/2"

DIMENSIONS DRAWINGS EPP4 BASIC 1/4"

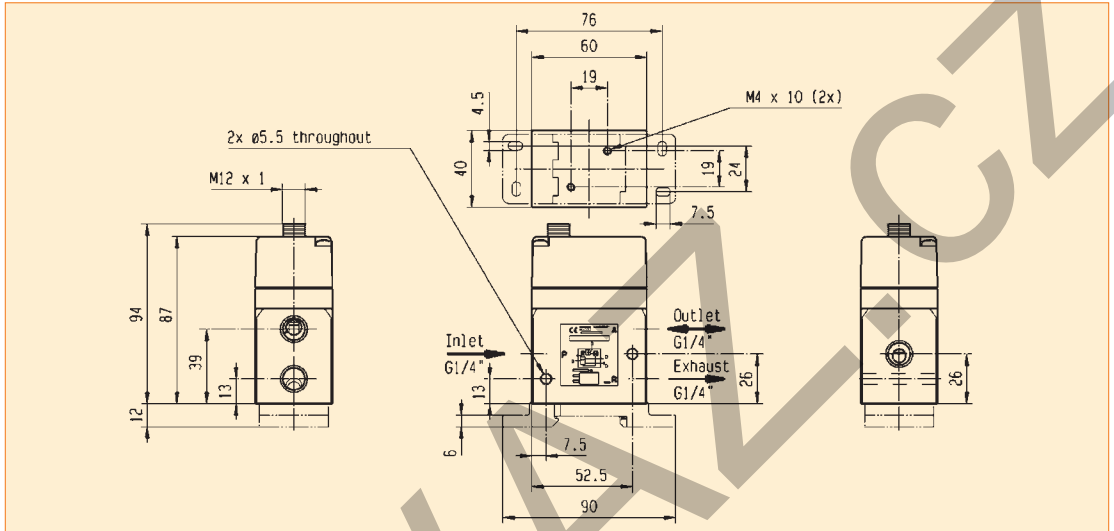

Drawing 1

DIMENSIONS DRAWINGS EPP4 BASIC 1/2"

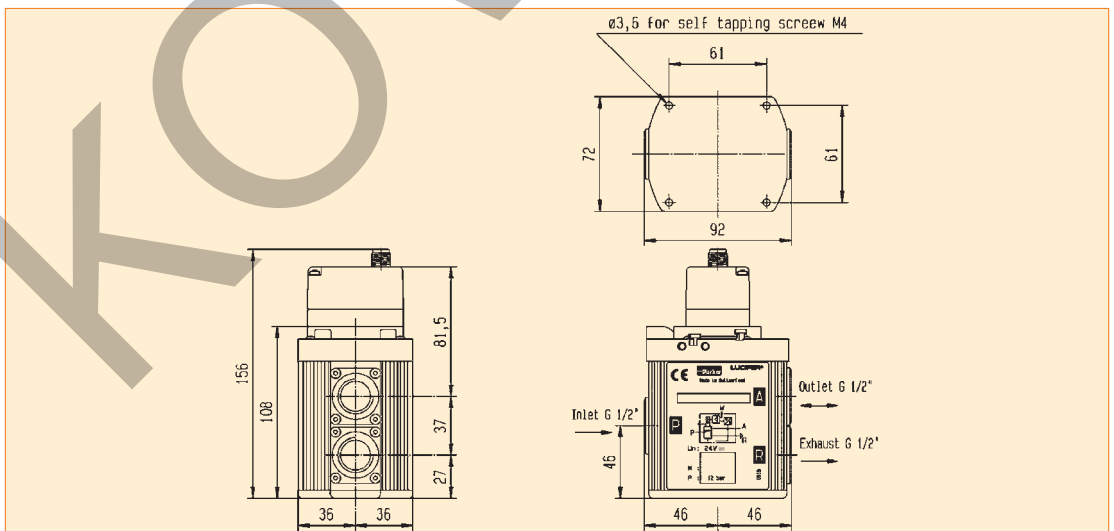

Drawing 2

EPP4 COMFORT 1/4" & 1/2"

Basic	1/4" 1/2"
Comfort	1/4" 1/2"
Comfort	1/2" HP 1" 2"
Comfort ATEX	1/2" 1" 2"

TECHNICAL DATA

	Comfort 1/4"	Comfort 1/2"
Fluids:	Lubricated or non lubricated air and neutral gases - Recommended filtration: 50 µm	
Temperature range:	Ambient: 0°C to +50 °C Fluid: 0°C to +50 °C	
Inlet pressure range: The inlet pressure must always be at least 1 bar above the regulated pressure.	1 to 12 bar	1 to 12 bar
Outlet pressure range:	0.05 bis 10 bar	
Hysteresis:	± 50 mbar (factory set up)	
Air consumption at constant control signal:	0	
Supply voltage:	24 V DC ± 15 % (Max. ripple 1 V)	
Power consumption:	Max. 2.8 W with 24 V DC and constant changes of the control signal < 1.5 W without change of control signal	
Control signal:	Analog 0 - 10 V Analog 4 - 20 mA	
Outlet sensor signal:	Analog 0 - 10 V Standard for 0 - 10 bar; Adjustable Analog 4 - 20 mA Standard for 0 - 10 bar; Adjustable	Digital 0/24 V for alarm features: Adjustable pressure error (+/-) Adjustable delay ON Adjustable delay OFF Adjustable logic (+/-)
Max. flow:	70 m³/h	150 m³/h
Indicative response time:	With a volume of 330 cm³ at the outlet of the regulator	
Filling 2 to 4 bar :	50 msec	60 msec
Filling 2 to 8 bar:	100 msec	120 msec
Emptying 4 to 2 bar:	70 msec	90 msec
Emptying 8 to 2 bar:	130 msec	190 msec
Safety position:	In case of control signal failure or if it is less than 50 mV, the regulated pressure drops automatically to 0 bar (atmospheric pressure). In case of voltage supply failure, the regulated pressure will be kept constant.	
Electrical connection:	M12 - 8 pin; male connector power supply/control signal M12 - 5 pin; male connector communication	
Life expectancy:	> 50 Million changes of control signal steps	
Mounting position:	Indifferent (recommended position: upright; electronic part on top)	
Resistance to vibrations:	30 g in all directions	
Degree of protection:	IP 65	
Assembly:	Silicone free	
Electromagnetic compatibility: In accordance with:	EN 61000-6-1: 2001 EN 61000-6-2: 2001 EN 61000-6-3: 2001 + A11 2004 edition (01/07/07) EN 61000-6-4: 2001	
Installation and setting instructions:	See our "Notice 408128, 408134" and appendix supplied with the product.	

Note: Parker reserves the right to change specifications without notification.

EPP4 COMFORT 1/4" & 1/2"

Flow Curves

Flow Curve 1/4"

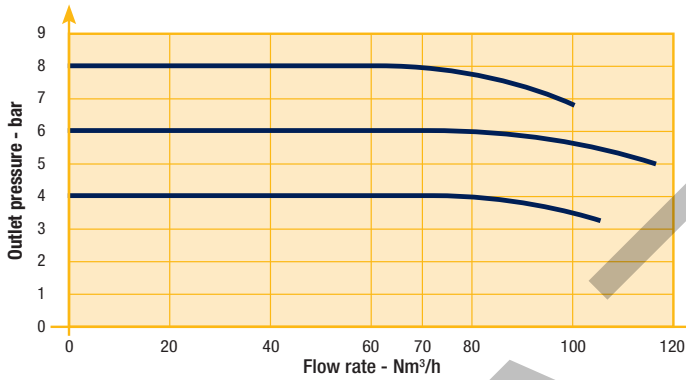

Flow Curve 1/2"

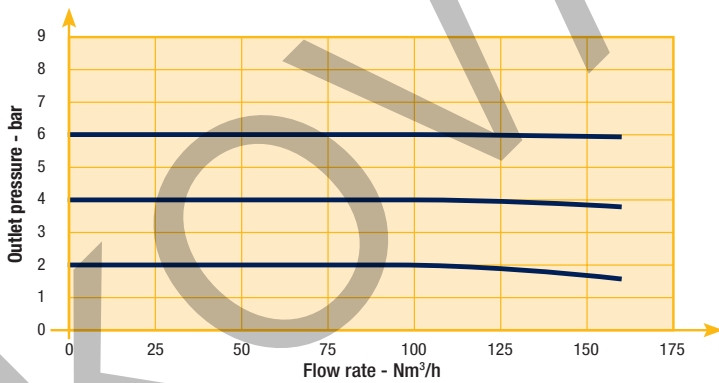

EPP4 COMFORT 1/4" & 1/2"

REFERENCES

Codes	Pipe	Pressure Range (bar)		Control Signal (see options)	Display	Drawing Number
P4CG2001C001	G 1/4	0	10	0-10 V	-	3
P4CG2001C002	G 1/4	0	10	4-20 mA	-	3
P4CG2001C005	G 1/4	0	7	0-10 V	-	3
P4CG2001C006	G 1/4	0	7	4-20 mA	-	3
P4CG2002C001	G 1/4	0	10	0-10 V	included	3
P4CG2002C002	G 1/4	0	10	4-20 mA	included	3
P4CG2003C001 *	G 1/4	0	10	0-10 V	-	3
P4CG2003C002 *	G 1/4	0	10	4-20 mA	-	3
P4CG2002C007	G 1/4	0	7	0-10 V	-	3
P4CG2002C008	G 1/4	0	7	4-20 mA	-	3
P4CN2001C001	1/4 NPT	0	10	0-10 V	-	3
P4CN2001C002	1/4 NPT	0	10	4-20 mA	-	3
P4CN2002C001	1/4 NPT	0	10	0-10 V	included	3
P4CN2002C002	1/4 NPT	0	10	4-20 mA	included	3
P4CG4001C001	G 1/2	0	10	0-10 V	-	4
P4CG4001C002	G 1/2	0	10	4-20 mA	-	4
P4CG4001C005	G 1/2	0	7	0-10 V	-	4
P4CG4001C006	G 1/2	0	7	4-20 mA	-	4
P4CG4002C001	G 1/2	0	10	0-10 V	included	4
P4CG4002C002	G 1/2	0	10	4-20 mA	included	4
P4CG4002C005	G 1/2	0	7	0-10 V	-	4
P4CG4002C006	G 1/2	0	7	4-20 mA	-	4
P4CG4051C001 **	G 1/2	0	10	0-10 V	-	4
P4CG4051C002 **	G 1/2	0	10	4-20 mA	-	4
P4CN4001C001	1/2 NPT	0	10	0-10 V	-	4
P4CN4001C002	1/2 NPT	0	10	4-20 mA	-	4
P4CN4002C001	1/2 NPT	0	10	0-10 V	included	4
P4CN4002C002	1/2 NPT	0	10	4-20 mA	included	4

* Integrated pilot exhaust

** O2



EPP4 COMFORT 1/4" & 1/2"

DIMENSIONS DRAWINGS EPP4 COMFORT RANGE 1/4"

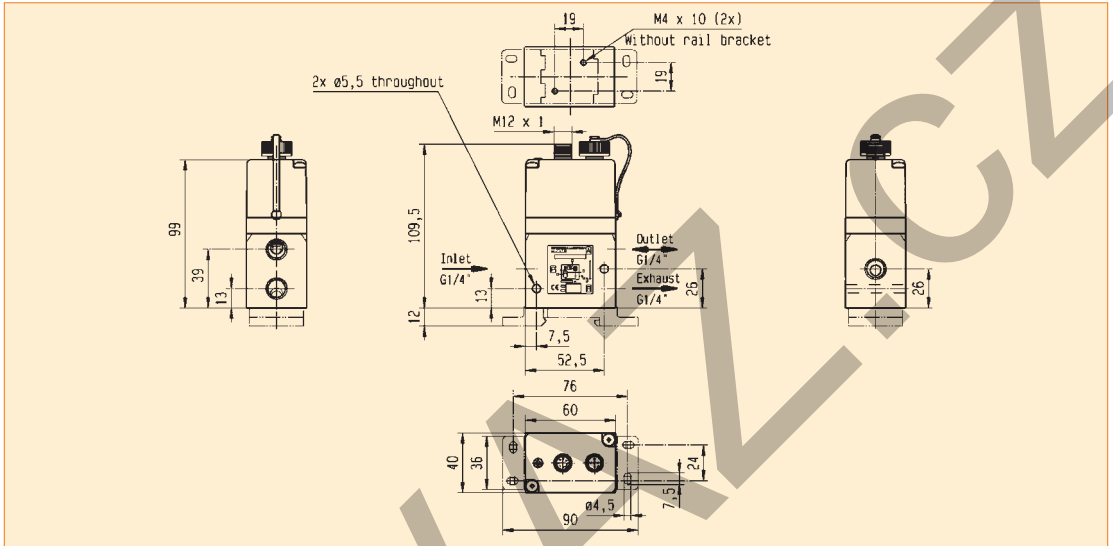

Drawing 3

DIMENSIONS DRAWINGS EPP4 COMFORT RANGE 1/2"

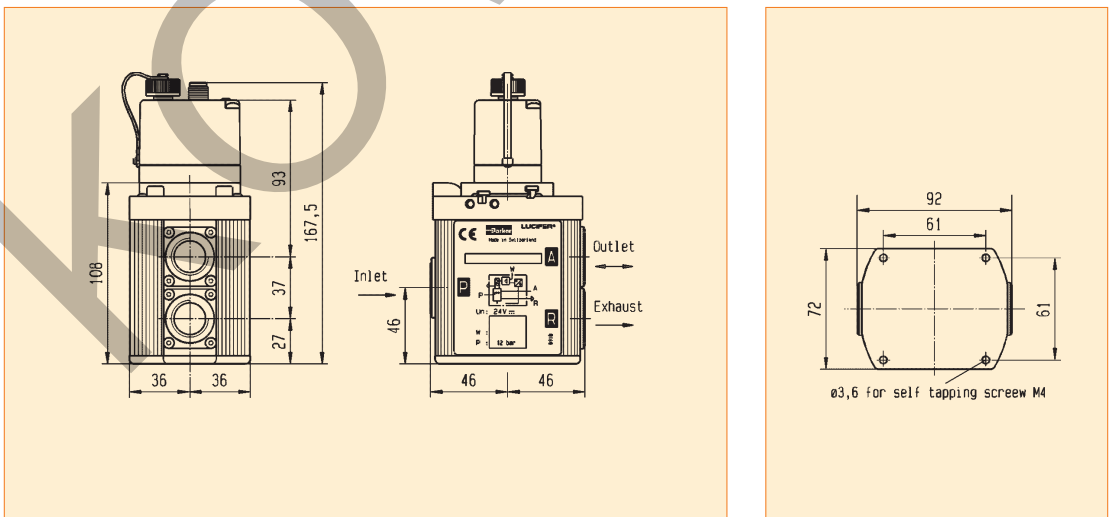

Drawing 4

EPP4 COMFORT 1/2"HP, 1" & 2"

Basic	1/4" 1/2"
Comfort	1/4" 1/2"
Comfort	1/2" HP 1" 2"
Comfort ATEX	1/2" 1" 2"

TECHNICAL DATA

	Comfort 1/2" HP	Comfort 1"	Comfort 2"
Fluids:	Lubricated or non lubricated air and neutral gases - Recommended filtration: 50 µm		
Temperature range:	Ambient: 0°C to +50°C Fluid: 0°C to +50°C		
Inlet pressure range: The inlet pressure must always be at least 1 bar above the regulated pressure.	1 to 21 bar	1 to 21 bar	1 to 12 bar
Outlet pressure range:	0.05 to 20 bar	0.05 to 20 bar	0.05 to 10 bar
Hysteresis:	≤ 100 mbar if P inlet ≤ 10 bar ≤ 200 mbar if P inlet > 10 bar		
Air consumption at constant control signal:	0		
Supply voltage:	24V DC ± 15%		
Power consumption:	Max. 6 W with 24 V DC and constant changes of the control signal < 2 W without change of control signal		
Control signal:	Analog 0 - 10 V Analog 4 - 20 mA		
Outlet sensor signal:	Analog 0 - 10 V Standard for 0 - 10 bar; Adjustable	Digital 0/24 V for alarm features: Adjustable pressure error (+/-) Adjustable delay ON Adjustable delay OFF Adjustable logic (+/-)	
	Analog 4 - 20 mA Standard for 0 - 10 bar; Adjustable		
Max. flow:	150 m³/h	1 000 m³/h	2 700 m³/h
Indicative response time:	With a volume of 330 cm³ at the outlet of the regulator		
Filling 2 to 8 bar:	120 msec	250 msec	250 msec
Emptying 8 to 2 bar:	190 msec	400 msec	400 msec
Safety position:	In case of control signal failure or if it is less than 50 mV, the regulated pressure drops automatically to 0 bar atmospheric pressure (for pressure ranges from 0-10 bar, 100 mV for pressure range over 10 bar). In case of voltage supply failure, the regulated pressure will be kept constant.		
Electrical connection:	M12 - 8 pin; male connector power supply/control signal M12 - 5 pin; male connector communication		
Life expectancy:	> 20 Million changes of control signal steps		
Mounting position:	Indifferent (recommended position: upright; electronic part on top)		
Resistance to vibrations:	30 g in all directions		
Degree of protection:	IP 65		
Assembly:	Silicone free		
Electromagnetic compatibility: In accordance with:	EN 61000-6-1: 2001 EN 61000-6-2: 2001 EN 61000-6-3: 2001 + A11 2004 edition (01/07/07) EN 61000-6-4: 2001		
Installation and setting instructions:	See our "408 193" and appendix supplied with the product.		

Note: Parker reserves the right to change specifications without notification.

EPP4 COMFORT 1/2"HP, 1" & 2"

FLOW CURVES

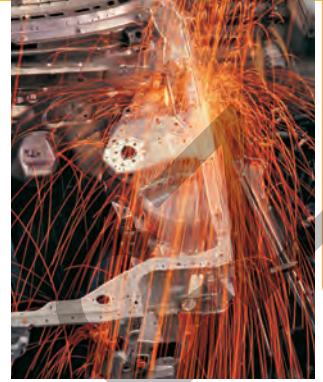

Flow Curve 1/2"HP

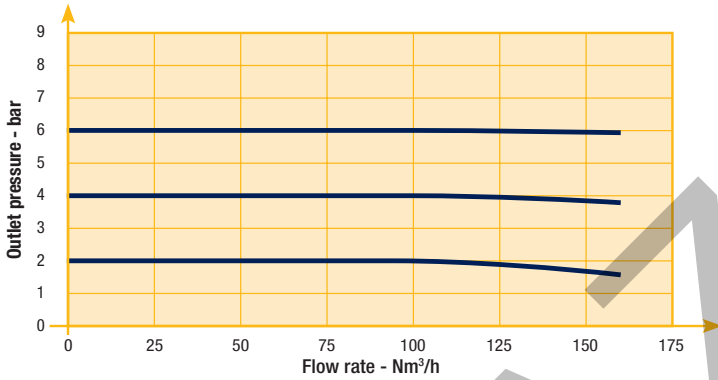

Flow Curve 1"

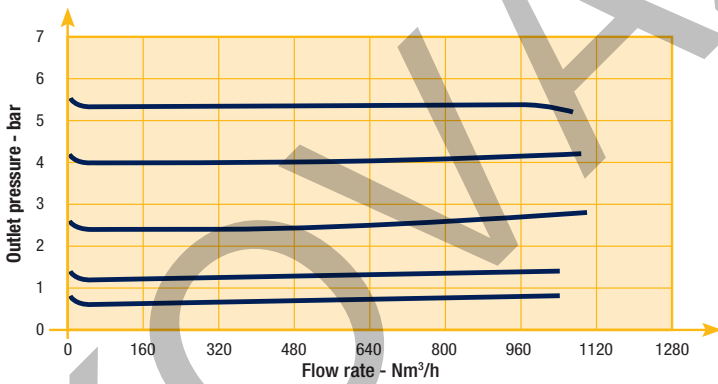

Flow Curve 2"

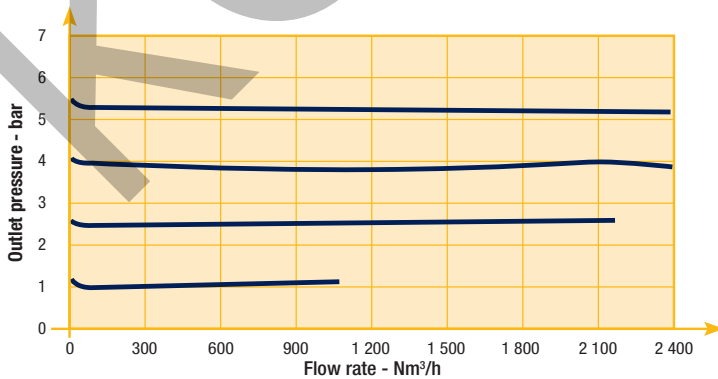

EPP4 COMFORT 1/2"HP

REFERENCES

Codes	Pipe	Max inlet pressure (bar)	Pressure range (bar)		Control signal (see options)	Dimensional Drawing
P4CG4101D001	G1/2	15	0	12	0-10 V	5
P4CG4201D005	G1/2	21	0	16	0-10 V	6
P4CG4201D003	G1/2	21	0	20	0-10 V	6
P4CG4201D004	G1/2	21	0	20	4-20 mA	6

Other specific settings or specialties are available, please contact us.



EPP4 COMFORT 1/2"HP

DIMENSIONS DRAWINGS

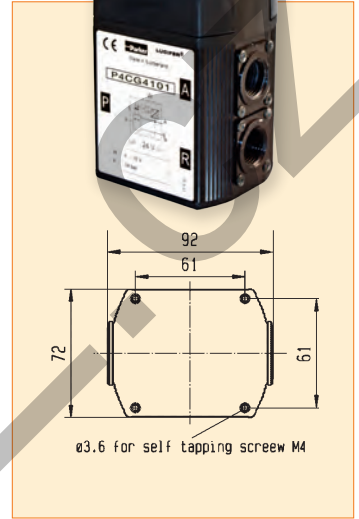
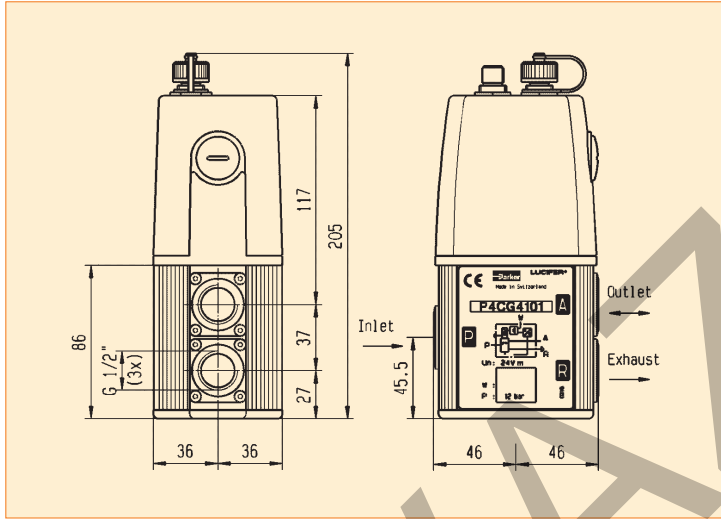

Drawing 5

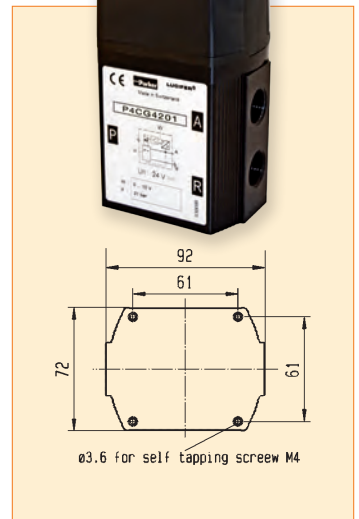
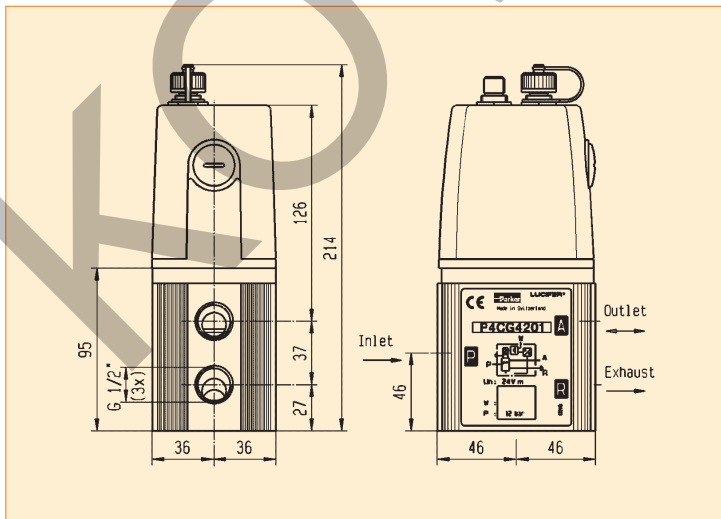

Drawing 6

EPP4 COMFORT 1" & 2"

REFERENCES

Codes	Pipe	Max inlet pressure (bar)	Pressure range (bar)		Control signal (see options)	Dimensional Drawing
P4CG6101C009	G1	12	0	3.5	4-20 mA	7
P4CG6101C011	G1	12	0	5.0	0-10 V	7
P4CG6101C010	G1	12	0	6.0	4-20 mA	7
P4CG6101C001	G1	12	0	10	0-10 V	7
P4CG6101C002	G1	12	0	10	4-20 mA	7
P4CG6201D001	G1	21	0	12	0-10 V	7
P4CG6201D003	G1	21	0	20	0-10 V	7
P4CG9101C012	G2	12	0	4.0	4-20 mA	8
P4CG9101C010	G2	12	0	6.0	4-20 mA	8
P4CG9101C001	G2	12	0	10	0-10 V	8
P4CG9101C002	G2	12	0	10	4-20 mA	8

Other specific settings or specialties are available, please contact us.

EPP4 COMFORT 1" & 2"

DIMENSIONS DRAWINGS EPP4 COMFORT RANGE 1"

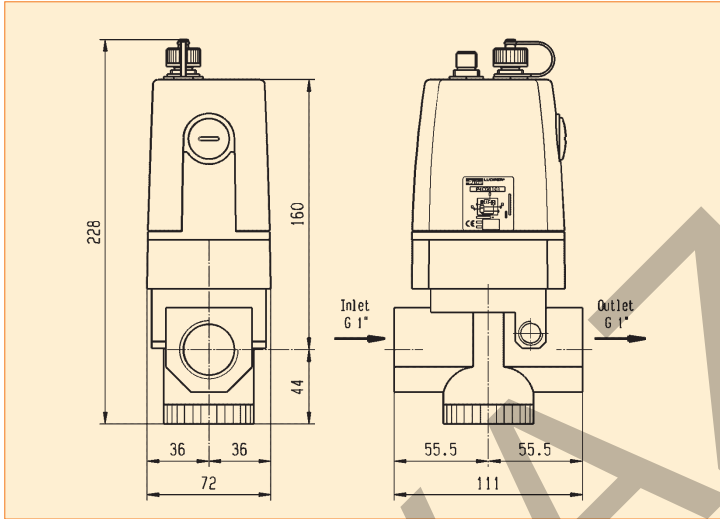

Drawing 7

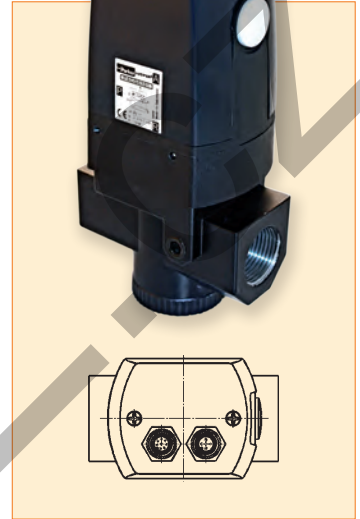

DIMENSIONS DRAWINGS EPP4 COMFORT RANGE 2"

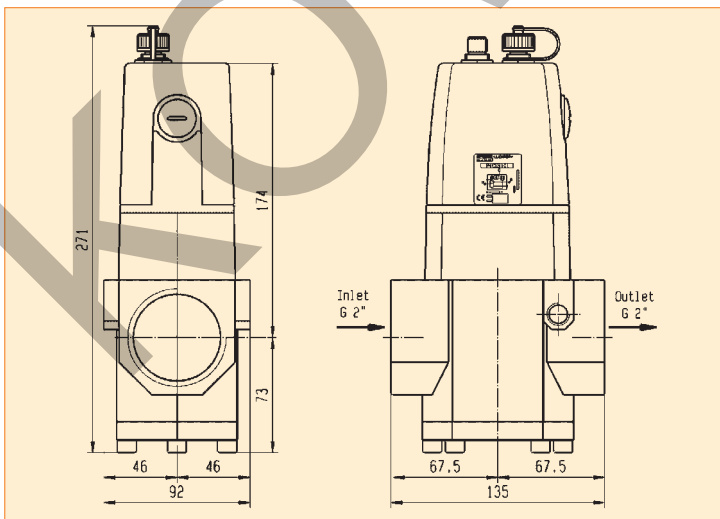

Drawing 8

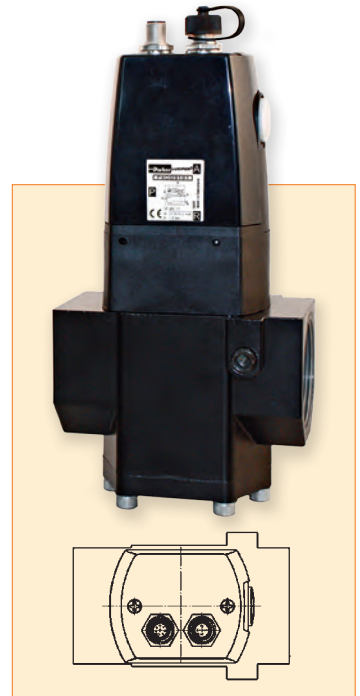

EPP4 COMFORT 1/2", 1" & 2" ATEX



Basic	1/4" 1/2"
Comfort	1/4" 1/2"
Comfort	1/2" HP 1" 2"
Comfort ATEX	1/2" 1" 2"

TECHNICAL DATA

	Comfort 1/2" ATEX	Comfort 1" ATEX	Comfort 2" ATEX
Fluids:	Lubricated or non lubricated air and neutral gases - Recommended filtration: 50 µm		
Temperature range:	Ambient: 0°C to +50°C Fluid: 0°C to +50°C		
Inlet pressure range: The inlet pressure must always be at least 1 bar above the regulated pressure.	Inlet pressure range: 1 to 12 bar		
Outlet pressure range:	Outlet pressure range: 0.05 to 10 bar		
Hysteresis:	≤ 100 mbar		
Air consumption at constant control signal:	0		
ATEX certification:	Ex II 3 G/D Ex nA IIC T4 Gc Ex tc IIIB T130°C Dc		
Supply voltage:	24V DC ± 15 %		
Power consumption:	Max. 6 W with 24 V DC and constant changes of the control signal < 2 W without change of control signal		
Control signal:	Analog 0 - 10 V Analog 4 - 20 mA		
Outlet sensor signal:	Analog 0 - 10 V Standard for 0 - 10 bar; Adjustable	Digital 0/24 V for alarm features: Adjustable pressure error (+/-) Adjustable delay ON Adjustable delay OFF Adjustable logic (+/-)	
	Analog 4 - 20 mA Standard for 0 - 10 bar; Adjustable		
Max. flow:	150 m³/h	1 000 m³/h	2 700 m³/h
Indicative response time:	With a volume of 330 cm³ at the outlet of the regulator		
Filling 2 to 8 bar:	120 msec	250 msec	250 msec
Emptying 8 to 2 bar:	190 msec	400 msec	400 msec
Safety position:	In case of control signal failure or if it is less than 50 mV, the regulated pressure drops automatically to 0 bar atmospheric pressure (for pressure ranges from 0-10 bar, 100 mV for pressure range over 10 bar). In case of voltage supply failure, the regulated pressure will be kept constant.		
Electrical connection:	M12 - 8 pin; male connector power supply/control signal M12 - 5 pin; male connector communication		
Life expectancy:	> 20 Million changes of control signal steps		
Mounting position:	Indifferent (recommended position: upright; electronic part on top)		
Resistance to vibrations:	30 g in all directions		
Degree of protection:	IP 54		
Assembly:	Silicone free		
Electromagnetic compatibility: In accordance with:	EN 61000-6-1: 2001 EN 61000-6-2: 2001 EN 61000-6-3: 2001 + A11 2004 edition (01/07/07) EN 61000-6-4: 2001		
Installation and setting instructions:	See our "408 283" and appendix supplied with the product.		

Note: Parker reserves the right to change specifications without notification.



EPP4 COMFORT 1/2", 1" & 2" ATEX

FLOW CURVES



Flow Curve 1/2"

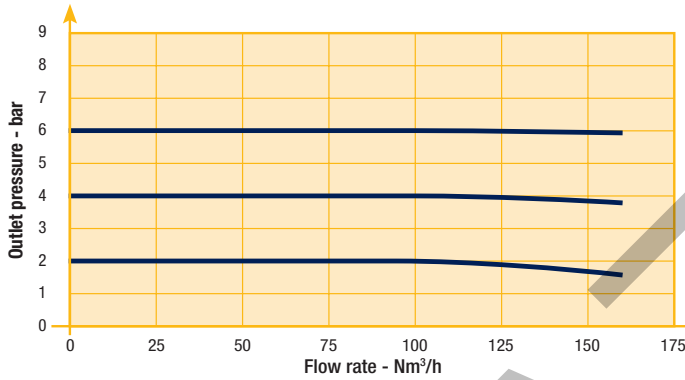

Flow Curve 1"

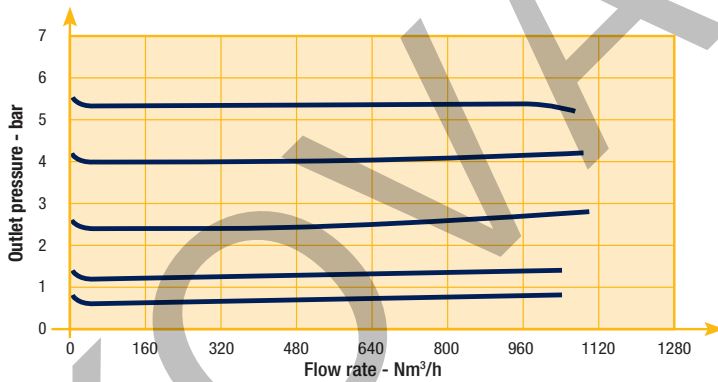

Flow Curve 2"

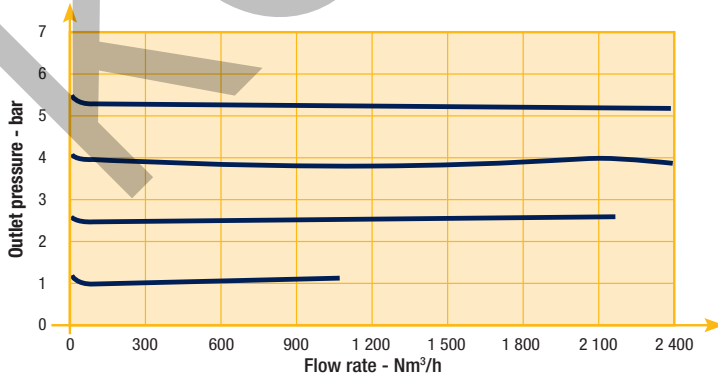

EPP4 COMFORT 1/2" ATEX



REFERENCES

Codes	Pipe	Max inlet pressure (bar)	Pressure range (bar)	Control signal (see options)	Dimensional Drawing
P4CG4461C001	G1/2	12	0 10	0-10 V	9
P4CG4461C002	G1/2	12	0 10	4-20 mA	9
P4CG4465C001 **	G1/2	12	0 10	0-10 V	9
P4CG4465C002 **	G1/2	12	0 10	4-20 mA	9

** 02

Other specific settings or specialties are available, please contact us.

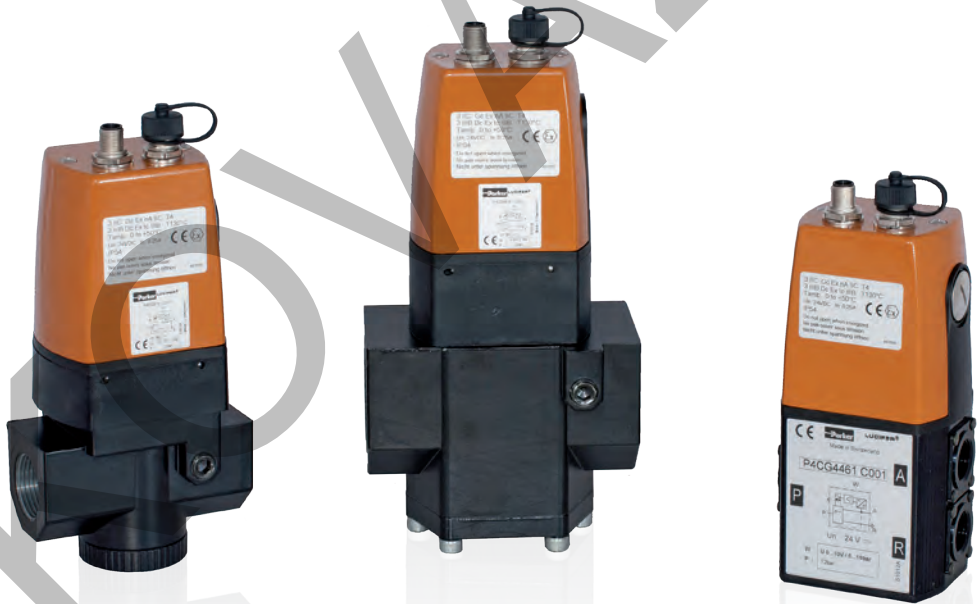

EPP4 COMFORT 1/2" ATEX



DIMENSIONS DRAWINGS

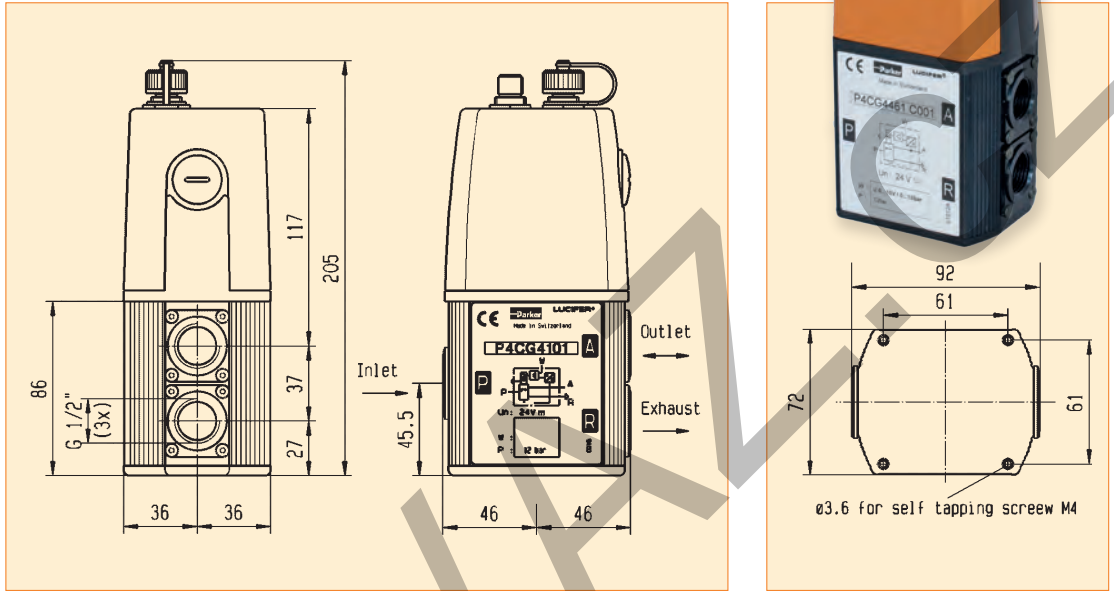

Drawing 9



EPP4 COMFORT 1" & 2" ATEX

REFERENCES

Codes	Pipe	Max inlet pressure (bar)	Pressure range (bar)		Control signal (see options)	Dimensional Drawing
P4CG6161C001	G1	12	0	10	0-10 V	11
P4CG6161C002	G1	12	0	10	4-20 mA	11
P4CG9161C001	G2	12	0	10	0-10 V	12
P4CG9161C002	G2	12	0	10	4-20 mA	12

Other specific settings or specialties are available, please contact us.

EPP4 COMFORT 1" & 2" ATEX



DIMENSIONS DRAWINGS EPP4 COMFORT RANGE 1"

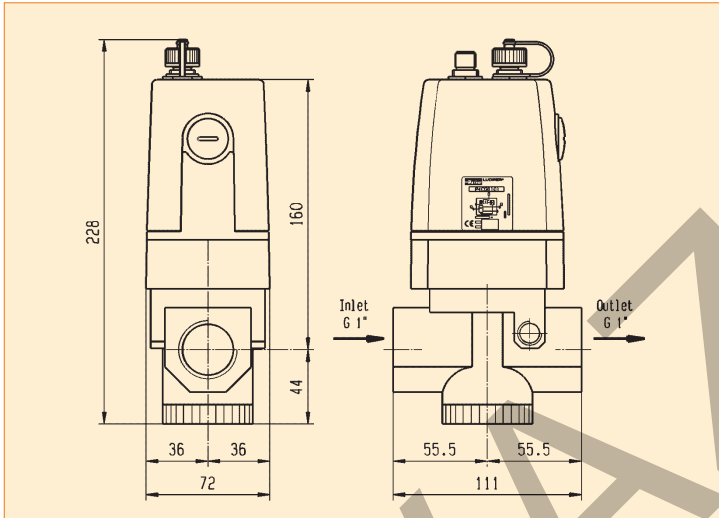

Drawing 11

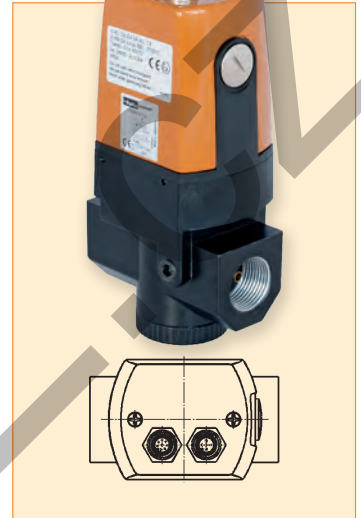

DIMENSIONS DRAWINGS EPP4 COMFORT RANGE 2"

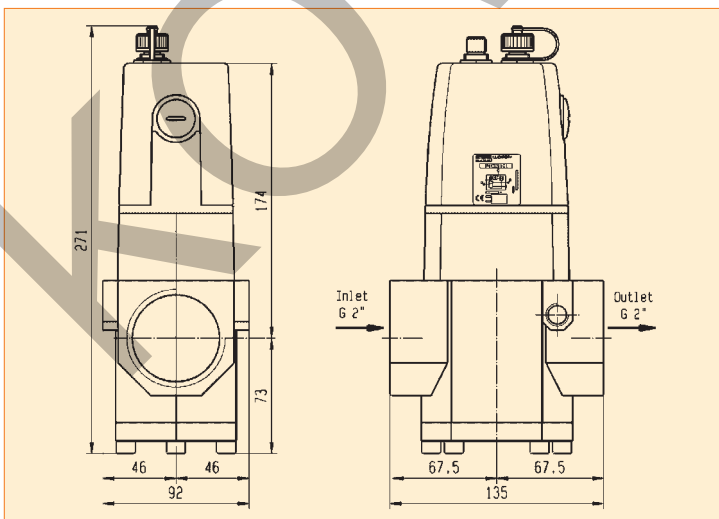

Drawing 12

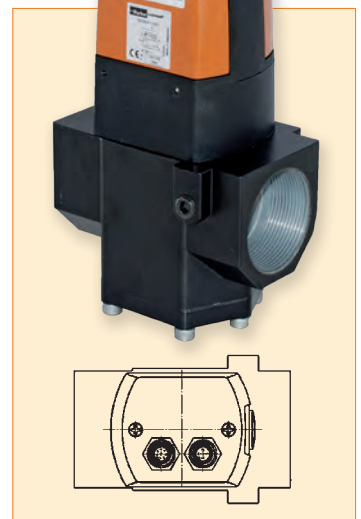

EPP4 ACCESSORIES

MOUNTING BRACKETS FOR EPP4 1/4" BASIC / COMFORT



This mounting bracket is delivered as a standard with all EPP4 1/4".

EPP4 ACCESSORIES

MOUNTING BRACKETS FOR EPP4 1/2" BASIC / COMFORT

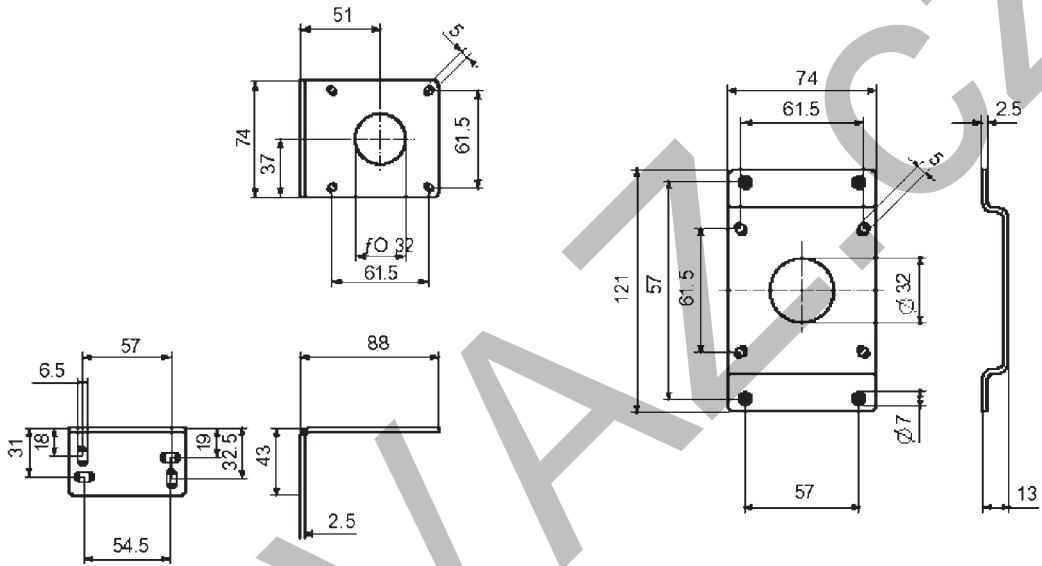

Order reference 491367



Order reference 491366

EPP4 ACCESSORIES

POWER SUPPLY/CONTROL SIGNAL CABLE FOR BASIC AND COMFORT VERSIONS.

Cable for Comfort EPP4

- 2 m cable with moulded straight M12-8 pole

Order Reference 496796

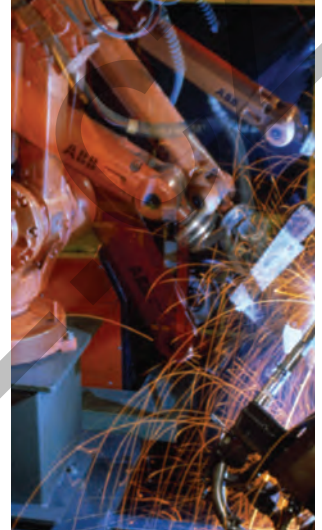

KOVLAVZ

EPP4 COMFORT ACCESSORIES

calys SOFTWARE

Calys is a unique software in house developed to configure all the parameters of the EPP4 Comfort range. Calys is an option of the EPP4. A specific cable is needed for the communication between the EPP4 and a PC.



Calys offers many capabilities:

- Live monitoring (control signal, regulated pressure, supply voltage,...)
- Recording of the main parameters (control signal, regulated pressure, supply voltage,...) in an Excel file
- Free calibration for the inputs and outputs
- Adjustable alarm (positive-negative, pressure limits, delays)
- Configuration files easy to duplicate
- Complete and interactive help file

Data in 4 different pressure units

Menus in 4 languages (English, German, French and Italian)

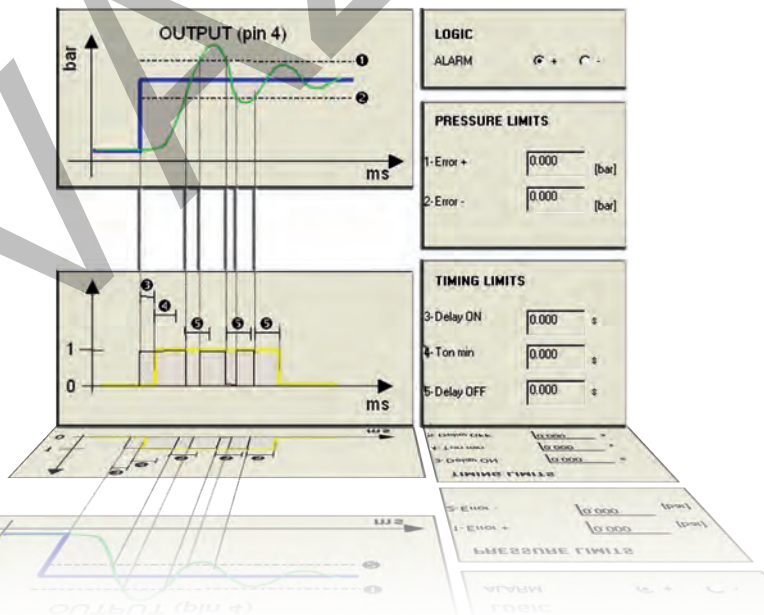

Specific communication cable PC-EPP4 with RS232 and USB connection

Order Reference 496449

This option is for safe area only.

KOVANZ.CZ

A COMPLETE RANGE OF COILS, HOUSINGS AND ELECTRICAL PARTS FOR SOLENOID VALVES



DEFINITIONS

HOUSINGS OR COIL ASSEMBLY KITS, COILS AND ELECTRICAL PARTS



Housing:

We define a **housing** as the combination of the fixing elements including the nameplate **1**, the cover **2** or the subplate **6** and the envelope itself **4** or **5** which protects the coil and its electrical components. The housings may be made of metal or plastic material.

Coil assembly kit:

The coil assembly kit **7** or **9** is the set comprising a plate, washer and nut. Sometimes coil assembly kits consist only of a nut or a special fixing device.

Coil:

This consists of the winding and its plastic moulding. There are three different types of coils distinguished by their shape and dimensions: 40 mm **3**, 32 mm **8** and 22 mm **10**.

Electric part:

The electric part is the set comprising the housing, the assembly kit and the coil.

Attention:

Any coil or electrical part must be energised only when properly mounted on a valve.

If not, a risk of damaging the product and its surroundings (overheating, explosion, fire, etc.) can take place.

TABLE OF CONTENT

INTRODUCTION

Index for Explosion Proof Electrical Parts.....	414
List of Coil Groups	415

COILS

Coils for DIN plug connection.....	418
Coils with flying leads.....	432
Coils with screw terminal	424
Coils with ISO-DIN connector	441

EXPLOSION PROOF ELECTRICAL PARTS

Level of protection "nAc nCc"	445
Level of protection "db"	452
Level of protection "mb"	453
Level of protection "db mb"	457
Level of protection "eb"	462
Level of protection "eb mb"	463
Level of protection "ia"	466

HOUSINGS	474
----------------	-----

COIL ACCESSORIES	478
------------------------	-----

EXPLOSIVE ENVIRONMENTS	480
------------------------------	-----

COIL APPENDICES

Guidance chart for IS-Barriers	490
--------------------------------------	-----

INDEX FOR EXPLOSION PROOF ELECTRICAL PARTS

Coil Reference	Coil Group	Designation	Power DC Pn (W)	Power AC Pn (W)	Ambient Temperature	UL	Degree of Protection	ATEX or NEMA 4X Protection (Gas)	Page
496637	1.2	Explosion proof electrical part "nAc nCc", 22 mm, double frequency	3.0	3.0	-40°C to +50°C	-	IP65	II 3 D Ex tc IIIC T 95°C	445
495880	2.0/2.2	Explosion proof electrical part "nAc nCc", 32 mm	14.0	14.0	-40°C to +50°C	-	IP65	II 3 G Ex nAc nCc IIC T3	449
496155	2.0/2.2	Explosion proof increased safety electrical part "nAc nCc", 50 mm	14.0	14.0	-40°C to +65°C	-	IP67	II 3 G Ex nAc nCc IIC T3	451
495915	4.0	Explosion proof increased safety electrical part "nAc nCc", 50 mm	13.0	11.0	-40°C to +65°C	-	IP67	II 3 G Ex nAc nCc IIC T3	450
495870	2.0/2.1	Explosion proof electrical part "nAc nCc", 32 mm	9.0	8.0	-40°C to +50°C	-	IP65	II 3 G Ex nAc nCc IIC T3/T4	446
495875	3.0	Explosion proof electrical part "nAc nCc", 32 mm	7.0	6.0	-40°C to +50°C	-	IP65	II 3 G Ex nAc nCc IIC T3/T4	448
496110	2.0/2.1	Explosion proof electrical part "nAc nCc", 32 mm	-	9.0	-40°C to +50°C	-	IP65	II 3 G Ex nAc nCc IIC T3/T4	446
495865	1.1	Explosion proof electrical part "nAc nCc", low power, 22 mm	2.5	2.0	-40°C to +50°C	-	IP65	II 3 G Ex nAc nCc IIC T5	444
496125	6.0	Explosion proof electrical part "nAc nCc", low power, 32 mm	1.6	-	-40°C to +50°C	-	IP65	II 3 G Ex nAc nCc IIC T5/T6	447
482605	1.1	Explosion proof encapsulated electrical part "mb", 32 mm	5.0	4.0	-40°C to +65°C	-	IP65	II 2 G Ex mb IIC T4/T5	453
482606	1.1	Explosion proof encapsulated electrical part "mb", low power, 32 mm	2.5	2.0	-40°C to +65°C	-	IP65	II 2 G Ex mb IIC T4/T5	453
492070	2.0/2.1	Explosion proof encapsulated electrical part "mb", with water proof metal housing, 50 mm	8.0	9.0	-40°C to +65°C	-	IP67	II 2 G Ex mb IIC T4/T5	454
HZ10	2.0/2.1	Explosion proof encapsulated electrical part "mb", double frequency	8.0	8.0	-40°C to +85°C	-	IP65	II 2 G - Ex mb IIC T3/T4/T5	455
HZ11	2.0/2.2	Explosion proof encapsulated electrical part "mb", double frequency	14.0	14	-40°C to +85°C	-	IP65	II 2 G - Ex mb IIC T3/T4/T5	456
497105	10.3	Flame proof electrical part "db", 50 mm	8.0	8.0	-50°C to +80°C	-	IP66	II 2 G Ex db IIC T4/T5/T6	452
493640	2.0/2.1	Flame proof encapsulated electrical part "db mb", double frequency	8.0	8.0	-40°C to +75°C	-	IP65	II 2 G Ex db mb IIC T4/T5	461
495905	2.0/2.1	Flame proof encapsulated electrical part "db mb", 37 mm	8.0	8.0	-40°C to +65°C	-	IP67	II 2 G Ex db mb IIC T4	458
496560	10.1	Flame proof encapsulated electrical part "db mb", 37 mm	8.0	8.0	-40°C to +65°C	-	IP67	II 2 G Ex db mb IIC T4	459
496800	10.1	Flame proof encapsulated electrical part "db mb", 37 mm	8.0	8.0	-40°C to +65°C	-	IP67	II 2 G Ex db mb IIC T4	460
495900	6.0	Flame proof encapsulated electrical part "db mb", low power, 37 mm	2.0	2.5	-40°C to +65°C	-	IP67	II 2 G Ex db mb IIC T4/T5/T6	457
496555	10.2	Flame proof encapsulated electrical part "db mb", 37 mm	6.0	6.0	-40°C to +65°C	-	IP67	II 2 G Ex db mb IIC T4/T5/T6	459
496700	10.2	Flame proof encapsulated electrical part "db mb", 37 mm	6.0	6.0	-40°C to +65°C	-	IP67	II 2 G Ex db mb IIC T4/T5/T6	460
494040	2.0/2.1	Explosion proof increased safety electrical part "eb", 50 mm	8.0	8.0	-40°C to +90°C	-	IP67	II 2 G Ex eb IIC T3/T4	462
483371	2.0/2.1	Explosion proof increased safety electrical part "eb", 50 mm	8.0	8.0	-40°C to +65°C	-	IP67	II 2 G Ex eb IIC T4	462
492190	2.0/2.1	Explosion proof increased safety and encapsulated elect. part "eb", 50 mm	9.0	11.0	-40°C to +75°C	-	IP66	II 2 G Ex eb mb IIC T3/T4	465
492310	10.1	Explosion proof increased safety and encapsulated electrical part "eb", 50 mm	6.0	6.0	-40°C to +75°C	-	IP66	II 2 G Ex eb mb IIC T4/T5	463
492210	9.0	Explosion proof increased safety and encapsulated electrical part "eb", "Booster", 50 mm	1.0 to 1.8	-	-40°C to +75°C	-	IP66	II 2 G Ex eb mb IIC T5/T6	464
495910	8.0	Explosion proof intrinsically safe electrical part "ia", "booster", 37 mm	0.3 to 1.2	-	-40°C to +80°C	-	IP67	II 1 G Ex ia IIC T4/T5/T6	467
496565	9.0	Explosion proof intrinsically safe electrical part "ia", "Booster", 37 mm	0.77 to 2.58	-	-40°C to +80°C	-	IP67	II 1 G Ex ia IIC T4/T5/T6	468
483580.01	7.0	Explosion proof intrinsically safe electrical part "ia", 32 mm	3.0	-	-40°C to +55°C	-	IP65	II 1 G Ex ia IIC T6	466
488560.01	7.0	Explosion proof intrinsically safe electrical part "ia", 50 mm	0.3 to 3.0	-	-40°C to +65°C	-	IP66	II 1 G Ex ia IIC T6	470
492965.01	9.0	Explosion proof intrinsically safe electrical part "ia", "Booster", 50 mm	0.3 to 2.3	-	-40°C to +65°C	-	IP66	II 1 G Ex ia IIC T6	469
482870.01	12.0	Explosion proof intrinsically safe electrical part "ia", 50 mm	3.0	-	-40°C to +65°C	-	IP66	II 1 G Ex ia IIC T6	471
490885	7.0	Explosion proof intrinsically safe electrical part, "NEMA", 50 mm	3.0	-	-40°C to +60°C	-	NEMA 4 - 4X	Cl. I, Div.I, Gr. A, B, C, D	470

LIST OF COIL GROUPS

Parker coils and electrical parts are classified by groups determining their compatibility with Parker solenoid valves.

Group	For application with
1.1	Standard valves or on 2000 Series with standard pilot
1.2	Standard valves or on 2000 Series for high flow
1.3	Standard valves or on 2000 Series of W coil
2.0	Standard valves or on 7000 Series with standard pilot
2.1	Standard valves or on 7000 Series, for coils 8 - 9 W
2.2	Standard valves or on 7000 Series, for coils 14 W
3.0	Standard valves or on 7000 Series with reduced power
4.0	Standard valves or on 7000 Series, for bistable (Impulse) coils or electrical parts
6.0	Special valves "97" or on 7000 Series, for Intrinsically safe coils or electrical parts
7.0	Special valves "90", for coils and intrinsically safe electrical parts
8.0	Special valves "97" or on 7000 Series, for Intrinsically safe coils or electrical parts with booster
9.0	Special valves "xx" or on 9000 Series, for Intrinsically safe coils or electrical parts with booster
10.1	Standard valves or on 9000 Series with standard pilot
10.2	Standard valves or on 9000 Series "db mb"
10.3	Special valves or on 8000 Series "d"
12.0	Standard valves or on 9000 Series with manual reset
13.0	Special valves or on 7000 Series for Transportation
14.1	Special valves or on 7000 Series for Oil Burners
14.2	Special valves or on 7000 Series for Oil Burners
14.3	Special valves or on 7000 Series for Oil Burners

KOVANZ.CZ

TABLE OF CONTENT

INTRODUCTION

Index for Explosion Proof Electrical Parts	414
List of Coil Groups	415

COILS

Coils for DIN plug connection.....	418
Coils with flying leads.....	432
Coils with screw terminal	434
Coils with ISO-DIN connector	441

EXPLOSION PROOF ELECTRICAL PARTS

Level of protection "nAc nCc"	445
Level of protection "db"	452
Level of protection "mb"	453
Level of protection "db mb"	457
Level of protection "eb"	462
Level of protection "eb mb"	463
Level of protection "ia"	466

HOUSINGS	474
----------------	-----

COIL ACCESSORIES	478
------------------------	-----

EXPLOSIVE ENVIRONMENTS	480
------------------------------	-----

COIL APPENDICES

Guidance chart for IS-Barriers	490
--------------------------------------	-----

2.0/2.1 COILS FOR DIN PLUG CONNECTION



COILS 32 mm

These coils can be mounted with every Parker solenoid valves corresponding to the specified Coil Group.
See column "Coil Group" within valve pages.

This is an encapsulated assembly comprising a coil, integral magnetic iron path and snap-on plug connection.

The synthetic material encapsulation provides an effective compact housing, offering full protection against dust, oil, water, etc.

Ease of mounting in confined space - offers shock and corrosion protection - simplifies conversion of existing equipment to other requirements, etc.

Coils conform to the IEC/CENELEC safety standards and complies with European low-voltage directive.



Specification		Standard			Double frequency		
Ref. (without DIN plug)		481865			483510		
Ref. (with DIN plug)							
Coil Group		2.0 / 2.1					
Degree of protection		IP65 according to IEC / EN 60529 standards (with DIN plug).					
Class of insulation		F 155°C					
Electrical connection		The coil is connected with a 2 P + E plug according to EN 175301-803 type A					
Ambient temperature		-40°C to +50°C The application is limited also by the temperature range of the valve.					
Elect. Power	DC	Pn (hot)	9 W				
		P (cold) 20°C	12 W				
	AC	Pn (holding)	8 W		9 W		
		Attraction cold	26 VA (9 W)		32 VA (10 W)		
Weight		130 g (without plug)					
Voltages "Un"		VAC/Hz	Code	VDC	Code	VAC/Hz	Code
-10% to +10% of the Un		24/50	A2	24	C2	24/50, 24/60	PO
		48/50	A4	48	C4	48/50, 48/60	S4
		110/50	A5	110	C5	110-115/50, 120/60	S5
		220-230/50	3D			220-240/50, 240/60	S6

To Order a Coil choose Coil Ref + Voltage Code, example: 481865 for 24 VDC = 481865C2

More voltage possibilities can be found in the table of voltage codes at the end of the coil section.

These coils must be used with suitable housings, see example below:

Please use the coil assembly kit Ref. 2995.

It is composed of a nameplate giving details of the valve type, a round washer and a nut to ensure the fixing between 32 mm coil and the valve.

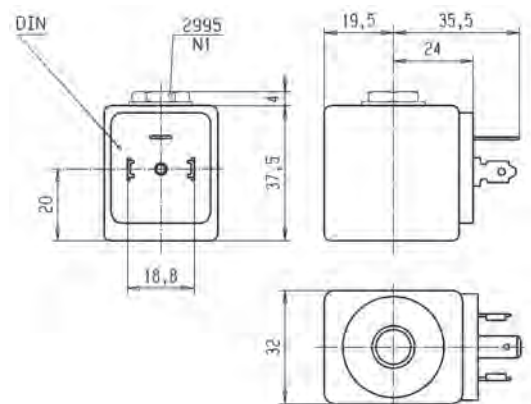
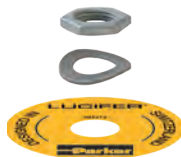

COIL GROUP
2.0/2.1
2.2

**COILS FOR
DIN PLUG CONNECTION**

HIGH TEMPERATURE COILS 32 mm

These coils can be mounted with every Parker solenoid valves corresponding to the specified Coil Group.
See column "Coil Group" within valve pages.

This is an encapsulated assembly comprising a coil, integral magnetic iron path and snap-on plug connection.

The synthetic material encapsulation provides an effective compact housing, offering full protection against dust, oil, water, etc.

Ease of mounting in confined space - offers shock and corrosion protection - simplifies conversion of existing equipment to other requirements, etc.

Coils conform to the IEC/CENELEC safety standards and complies with European low-voltage directive.



Specification		High temperature			High temp. + high power				
Ref. (without DIN plug) Ref. (with DIN plug)		492453			492425				
Coil Group		2.0 / 2.1			2.0 / 2.2				
Degree of protection		IP65 according to IEC / EN 60529 standards (with DIN plug).							
Class of insulation		H 180°C							
Electrical connection		The coil is connected with a 2 P + E plug according to EN 175301-803 type A							
Ambient temperature		-40°C to +50°C The application is limited also by the temperature range of the valve.							
Elect. Power	DC	Pn (hot)		9 W	14 W				
		P (cold) 20°C		12 W	21 W				
	AC	Pn (holding)		8 W	14 W				
		Attraction cold		26 VA (9 W)	55 VA (18 W)				
Weight		130 g (without plug)							
Voltages "Un"		VAC/Hz	Code	VDC	Code	VAC/Hz	Code	VDC	Code
-10% to +10% of the Un		24/50	A2	24	C2	24/50	A2	24	C2
		110/50	A5			110/50	A5		
		220/50-230/50	3D	110	C5	230/50	F4		

To Order a Coil choose Coil Ref + Voltage Code, example: 492453 for 24 VDC= 492453C2

More voltage possibilities can be found in the table of voltage codes at the end of the coil section.

These coils must be used with suitable housings, see example below:

Please use the coil assembly kit Ref. 2995.

It is composed of a nameplate giving details of the valve type, a round washer and a nut to ensure the fixing between 32 mm coil and the valve.

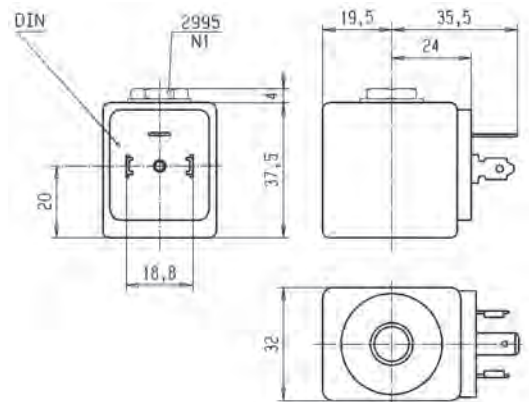

REDUCED POWER COIL 32 mm

These coils can be mounted with every Parker solenoid valves corresponding to the specified Coil Group.
See column "Coil Group" within valve pages.

This is an encapsulated assembly comprising a coil, integral magnetic iron path and snap-on plug connection.

The synthetic material encapsulation provides an effective compact housing, offering full protection against dust, oil, water, etc.

Ease of mounting in confined space - offers shock and corrosion protection - simplifies conversion of existing equipment to other requirements, etc.

Coils conform to the IEC/CENELEC safety standards and complies with European low-voltage directive.



Specification		Reduced power			
Ref. (without DIN plug) Ref. (with DIN plug)		482730			
Coil Group		3.0			
Degree of protection		IP65 according to IEC / EN 60529 standards (with DIN plug).			
Class of insulation		F 155°C			
Electrical connection		The coil is connected with a 2 P + E plug according to EN 175301-803 type A			
Ambient temperature		-40°C to +50°C The application is limited also by the temperature range of the valve.			
Elect. Power	DC	Pn (hot)	7 W		
		P (cold) 20°C	9 W		
	AC	Pn (holding)	6 W		
		Attraction cold	20 VA (7 W)		
Weight		130 g (without plug)			
Voltages "Un"		VAC/Hz	Code	VDC	Code
-10% to +10% of the Un		220-230/50	3D	24	C2

To Order a Coil choose Coil Ref + Voltage Code, example: 482730 for 24 VDC = 482730C2

More voltage possibilities can be found in the table of voltage codes at the end of the coil section.

These coils must be used with suitable housings, see example below:

Please use the coil assembly kit Ref. 2995.

It is composed of a nameplate giving details of the valve type, a round washer and a nut to ensure the fixing between 32 mm coil and the valve.

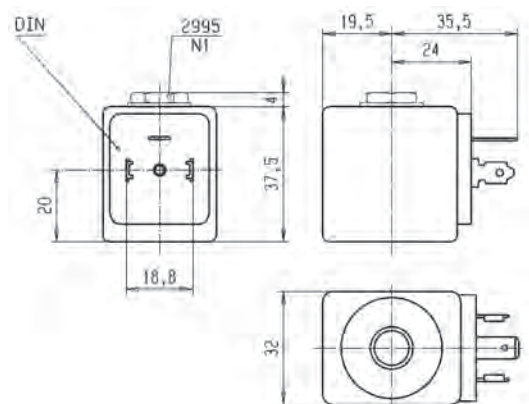
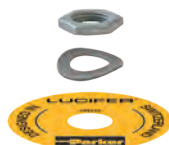

LOW POWER COIL 32 mm

These coils can be mounted with every Parker solenoid valves corresponding to the specified Coil Group.
See column "Coil Group" within valve pages.

This is an encapsulated assembly comprising a coil, integral magnetic iron path and snap-on plug connection.

The synthetic material encapsulation provides an effective compact housing, offering full protection against dust, oil, water, etc.

Ease of mounting in confined space - offers shock and corrosion protection - simplifies conversion of existing equipment to other requirements, etc.

Coils conform to the IEC/CENELEC safety standards and complies with European low-voltage directive.



Specification		Miniwatt	
Reference (without DIN plug)		482740	
Reference (with DIN plug)			
Coil Group		6.0	
Degree of protection		IP65 according to IEC / EN 60529 standards (with DIN plug).	
Class of insulation		F 155°C	
Electrical connection		The coil is connected with a 2 P + E plug according to EN 175301-803 type A	
Ambient temperature		-40°C to +50°C The application is limited also by the temperature range of the valve.	
Elect. Power	DC	Pn (hot)	1.6 W
		P (cold) 20°C	2.1 W
	AC	Pn (holding)	-
		Attraction cold	-
Weight		130 g (without plug)	
Voltages "Un"		VDC	Code
-10% to +10% of the Un		24	C2

To Order a Coil choose Coil Ref + Voltage Code, example: 482740 for 24 VDC = 482740C2

More voltage possibilities can be found in the table of voltage codes at the end of the coil section.

These coils must be used with suitable housings, see example below:

Please use the coil assembly kit Ref. 2995.

It is composed of a nameplate giving details of the valve type, a round washer and a nut to ensure the fixing between 32 mm coil and the valve.

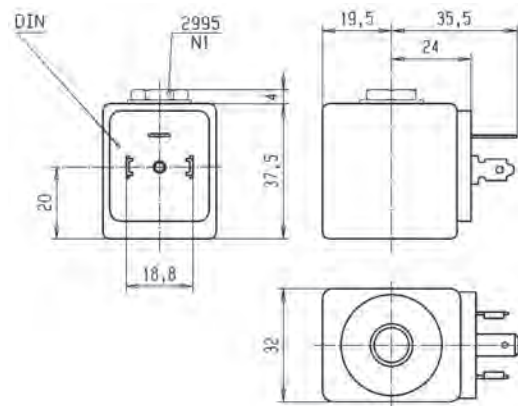
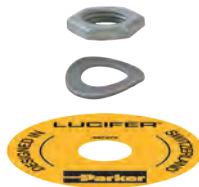



UL COIL 32 mm

This coil can be mounted with every Parker solenoid valves corresponding to the specified Coil Group.

See column "Coil Group" within valve pages.

This is an encapsulated assembly comprising a coil, integral magnetic iron path and snap-on plug connection.

The synthetic material encapsulation provides an effective compact housing, offering full protection against dust, oil, water, etc.

Ease of mounting in confined space - offers shock and corrosion protection - simplifies conversion of existing equipment to other requirements, etc.

Coils conform to the IEC/CENELEC safety standards and complies with European low-voltage directive.

DIN plug connector to be ordered separately (see coil accessories section)



Specification		UL-recognized coil - UL File E200N - designation AMIF			
Reference (without DIN plug)		491514			
Coil Group		2.0 / 2.1			
Degree of protection		IP65 according to IEC / EN 60529 standards (with DIN plug).			
Class of insulation		F 155°C			
Electrical connection		The coil is connected with a 2 P + E plug according to EN 175301-803 type A			
Ambient temperature		-40°C to 50°C The application is limited also by the temperature range of the valve.			
Elect. Power	DC	Pn (hot)	-	12 W	
		P (cold) 20°C	-	16 W	
	AC	Pn (holding)	11 W	-	
		Attraction cold	40 VA (13 W)	-	
Weight		130 g (without plug)			
Voltages "Un"		VAC/Hz	Code	VDC	Code
- 15% to +10% of the Un		110/50-120/60 220/50-240/60	P3 Q3	24	C2

To Order a Coil choose Coil Ref + Voltage Code, example: 491514 for 24 VDC = 491514C2

More voltage possibilities can be found in the table of voltage codes at the end of the coil section.

These coils must be used with suitable housings, see example below:

Please use the coil assembly kit Ref. 2995 with non UL valve and Ref. 2995.03 with UL valve.

It is composed of a nameplate giving details of the valve type, a round washer and a nut to ensure the fixing between 32 mm coil and the valve.

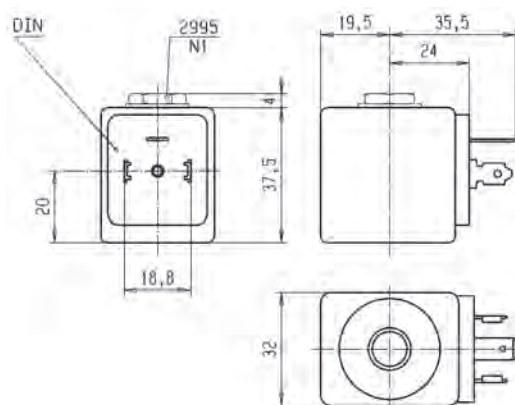
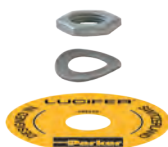

14.2

COILS FOR DIN PLUG CONNECTION



UL COIL 32 mm

These coils can be mounted with every Parker solenoid valves corresponding to the specified Coil Group. See column "Coil Group" within valve pages.

This is an encapsulated assembly comprising a coil, integral magnetic iron path and snap-on plug connection.

The synthetic material encapsulation provides an effective compact housing, offering full protection against dust, oil, water, etc.

Ease of mounting in confined space - offers shock and corrosion protection - simplifies conversion of existing equipment to other requirements, etc.

Coils conform to the IEC/CENELEC safety standards and complies with European low-voltage directive.



Specification		Coil for oil burner - UL recognized	
Reference (without DIN plug)		483764	
Coil group		14.2	
Degree of protection		IP65 according to IEC / EN 60529 standards (with DIN plug).	
Class of insulation		F 155°C	
Electrical connection		With DIN 43650 A Plug	
Ambient temperature		-40°C to 50°C The application is limited also by the temperature range of the valve.	
Elect. Power	DC	Pn (hot)	-
		P (cold) 20°C	-
	AC	Pn (holding)	9 W
		Attraction cold	-
Weight		138 g	
Voltages "Un"		VAC/Hz	Code
- 15% to +10% of the Un		240/50-60	Q1
		110/50-115/60	Q9
		230/50-240/60	T1

To Order a Coil choose Coil Ref + Voltage Code, example: 483764 for 240/50-60 = 483764Q1
More voltage possibilities can be found in the table of voltage codes at the end of the coil section.

These coils must be used with suitable housings, see example below:

Please use the coil assembly kit Ref. 2995.

It is composed of a nameplate giving details of the valve type, a round washer and a nut to ensure the fixing between 32 mm coil and the valve.

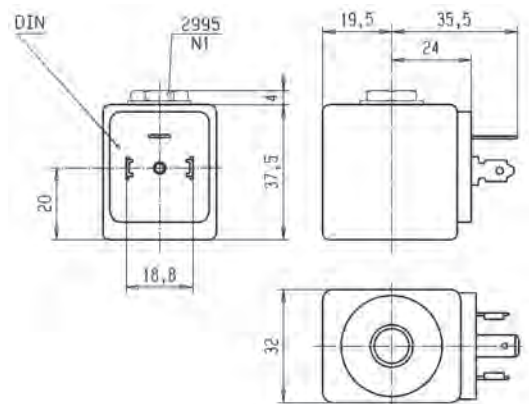

2.2

COILS FOR
DIN PLUG CONNECTION



COIL 32 mm FOR JET VALVES

This coil can be mounted with every Parker solenoid valves corresponding to the specified Coil Group.

See column "Coil Group" within valve pages.

This is an encapsulated assembly comprising a coil, integral magnetic iron path and snap-on plug connection.

The synthetic material encapsulation provides an effective compact housing, offering full protection against dust, oil, water, etc.

Ease of mounting in confined space - offers shock and corrosion protection - simplifies conversion of existing equipment to other requirements, etc.

Coils conform to the IEC/CENELEC safety standards and complies with European low-voltage directive.

DIN plug connector to be ordered separately (see coil accessories section)



Specification		32 mm coil 14 W	
Reference		483816	
Coil Group		2.2	
Degree of protection		IP65 according to IEC / EN 60529 standards (with DIN plug).	
Class of insulation		F 155°C	
Electrical connection		The coil is connected with a 2 P + E plug according to EN 175301-803 type A	
Ambient temperature		-40°C to +50°C The application is limited also by the temperature range of the valve.	
Elect. Power	DC	Pn (hot)	14 W
		P (cold) 20°C	-
	AC	Pn (holding)	14 W
		Attraction cold	-
Weight		160 g	
Voltages "Un"		VDC	Code
-10% to +10% of the Un		24 V	C2

To Order a Coil choose Coil Ref + Voltage Code, example: 483816 for 24 VDC = 483816C2

More voltage possibilities can be found in the table of voltage codes at the end of the coil section.

These coils must be used with suitable housings, see example below:

Please use the coil assembly kit Ref. 2995.

It is composed of a nameplate giving details of the valve type, a round washer and a nut to ensure the fixing between 32 mm coil and the valve.

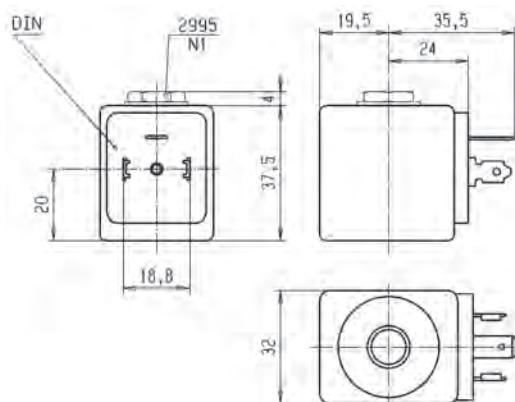
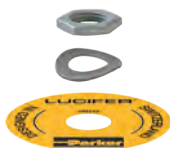

COIL GROUP

1.1

COILS FOR DIN PLUG CONNECTION



COILS 22 mm

This coil can be mounted with every Parker solenoid valves corresponding to the specified Coil Group.

See column "Coil Group" within valve pages.

This is an encapsulated assembly comprising a coil, integral magnetic iron path and snap-on plug connection.

The synthetic material encapsulation provides an effective compact housing, offering full protection against dust, oil, water, etc.

Ease of mounting in confined space - offers shock and corrosion protection - simplifies conversion of existing equipment to other requirements, etc.

Coils conform to the IEC/CENELEC safety standards and complies with European low-voltage directive.

DIN plug connector to be ordered separately (see coil accessories section)



Specification		Low power			High power				
Ref. (without DIN plug)		488980			481180				
Ref. (with DIN plug)									
Coil Group		1.1							
Degree of protection		IP65 according to IEC / EN 60529 standards (with DIN plug).							
Class of insulation		F 155°C							
Electrical connection		The coil is connected with a 2 P + E plug according to EN 175301-803 type B.							
Ambient temperature		-40°C to +50°C The application is limited also by the temperature range of the valve.							
Elect. Power	DC	Pn (hot)	2.5 W			5 W			
		P (cold) 20°C	3 W			6.5 W			
	AC	Pn (holding)	2 W			4 W			
		Attraction cold	5.7 VA (2.5 W)			8.9 VA (5 W)			
Weight		100 g with DIN Plug							
Voltages "Un"		VAC/Hz	Code	VDC	Code	VAC/Hz	Code	VDC	Code
-10% to +10% of the Un		24/50	A2	24	C2	24/50	A2	24	C2
		48/50	A4	48	C4	110/50-115/50	0A		
		110/50-115/50	0A	110	C5	220/50-230/50	3D		
		220/50-230/50	3D						

To Order a Coil choose Coil Ref + Voltage Code, example: 488980 for 24 VDC = 488980C2

More voltage possibilities can be found in the table of voltage codes at the end of the coil section.

These coils must be used with suitable housings, see example below:

Please use the coil assembly kit Ref. 8993.

It is composed of a nameplate with the details of the valve type, a washer and a nut to secure the 22 mm coil to the valve.

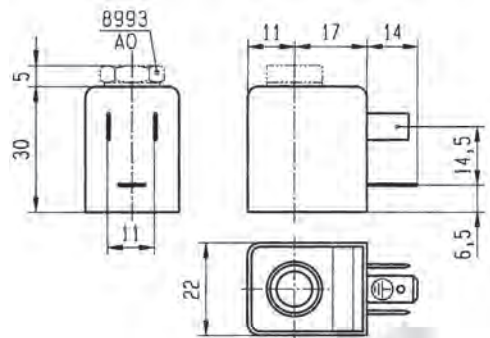
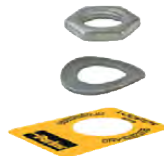

COIL 22 mm

These coils can be mounted with every Parker solenoid valves corresponding to the specified Coil Group.
See column "Coil Group" within valve pages.

This coil is designed for valves equipped with a miniature tube assembly (2000 series valves). This is an encapsulated assembly comprising a coil, integral magnetic iron path and snap-on plug connection.

The synthetic material encapsulation provides an effective compact housing, offering full protection against dust, oil, water, etc.

Ease of mounting in confined space - offers shock and corrosion protection - simplifies conversion of existing equipment to other requirements, etc.

Coil conforms to the IEC/CENELEC safety standards and complies with European low-voltage directive.

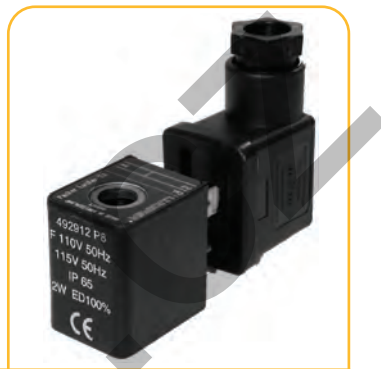

Specification		Standard (only if used with 321K, 121M, 131M valves)			
Reference (without DIN plug)		492912			
Reference (with DIN plug)		492912			
Coil Group		1.1			
Degree of protection		IP65 according to IEC / EN 60529 standards (with DIN plug).			
Class of insulation		A 105°C for UL/CSA			
Electrical connection		The coil is connected with a 2 P + E plug according to EN 175301-803 type B.			
Ambient temperature		-40°C to +50°C The application is limited also by the temperature range of the valve.			
Elect. Power	DC	Pn (hot)	4 W		
		P (cold) 20°C	4.5 W		
	AC	Pn (holding)	3 W		
		Attraction cold	7.5 VA (4 W)		
Weight		100 g with DIN Plug			
Voltages "Un"		VAC/Hz	Code	VDC	Code
- 15% to +10% of the Un		115/50-120/60	P8	24	C2

To Order a Coil choose Coil Ref + Voltage Code, example: 492912 for 24 VDC = 492912C2

More voltage possibilities can be found in the table of voltage codes at the end of the coil section.

These coils must be used with suitable housings, see example below:

Please use the coil assembly kit Ref. 8993.

It is composed of a nameplate giving details of the valve type, a round washer and a nut to ensure the fixing between 22 mm coil and the valve.

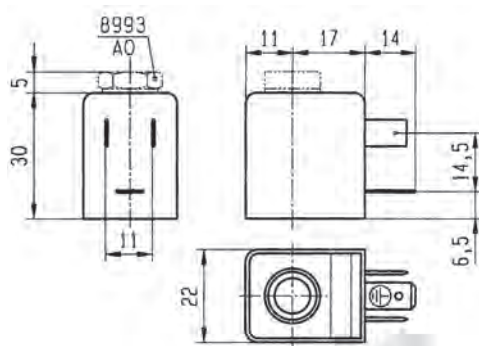



DOUBLE FREQUENCY COIL 22 mm

This coil can be mounted with every Parker solenoid valves corresponding to the specified Coil Group.
See column "Coil Group" within valve pages.

This coil is designed for valves equipped with a miniature tube assembly (2000 series valves). This is an encapsulated assembly comprising a coil, integral magnetic iron path and snap-on plug connection.

The synthetic material encapsulation provides an effective compact housing, offering full protection against dust, oil, water, etc.

Ease of mounting in confined space - offers shock and corrosion protection - simplifies conversion of existing equipment to other requirements, etc.

Coil conforms to the IEC/CENELEC safety standards and complies with European low-voltage directive.

DIN plug connector to be ordered separately (see coil accessories section).



Specification		Double frequency	
Reference (without DIN plug)		483590	
Coil group		1.1	
Degree of protection		IP65 according to IEC / EN 60529 standards (with DIN plug).	
Class of insulation		F 155°C	
Electrical connection		The coil is connected with a 2 P + E plug according to EN 175301-803 type B.	
Ambient temperature		-40°C to +50°C The application is limited also by the temperature range of the valve.	
Elect. Power	DC	Pn (hot)	-
		P (cold) 20°C	-
AC		Pn (holding)	3 W
		Attraction cold	7.5 VA (4 W)
Weight		100 g with DIN Plug	
Voltages "Un"		VAC/Hz	Code
-10% to +10% of the Un		24/50-60	P0
		110-115/50, 120/60	S5
		220-240/50, 240/60	S6

To Order a Coil choose Coil Ref + Voltage Code, example: 483590 for 24/50,24/60 = 483590P0

More voltage possibilities can be found in the table of voltage codes at the end of the coil section.

These coils must be used with suitable housings, see example below:

Please use the coil assembly kit Ref. 8993.

It is composed of a nameplate giving details of the valve type, a round washer and a nut to ensure the fixing between 22 mm coil and the valve.

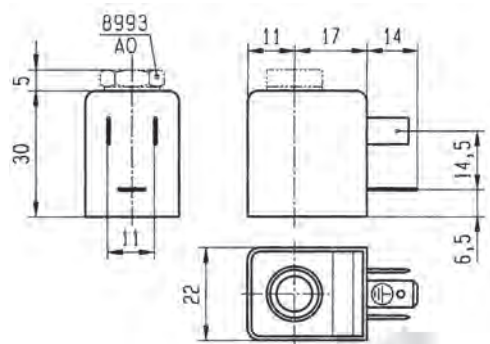

DOUBLE FREQUENCY COIL 22 mm

This coil can be mounted with every Parker solenoid valves corresponding to the specified Coil Group.
See column "Coil Group" within valve pages.

This coil is designed for valves equipped with a miniature tube assembly (2000 series valves). This is an encapsulated assembly comprising a coil, integral magnetic iron path and snap-on plug connection.

The synthetic material encapsulation provides an effective compact housing, offering full protection against dust, oil, water, etc.

Ease of mounting in confined space - offers shock and corrosion protection - simplifies conversion of existing equipment to other requirements, etc.

Coil conforms to the IEC/CENELEC safety standards and complies with European low-voltage directive.

DIN plug connector to be ordered separately (see coil accessories section).



Specification		Double frequency	
Reference (without DIN Plug)		488143	
Coil group		1.1	
Degree of protection		IP65 according to IEC / EN 60529 standards (with DIN plug).	
Class of insulation		F 155°C	
Electrical connection		The coil is connected with a 2 P + E plug according to EN 175301-803 type B.	
Ambient temperature		-40°C to +50°C The application is limited also by the temperature range of the valve.	
Elect. Power	DC	Pn (hot)	-
		P (cold) 20°C	-
	AC	Pn (holding)	2.5 W
		Attraction cold	-
Weight		60 g	
Voltages "Un"		VAC/Hz	Code
-10% to +10% of the Un		200/50-60	P6

To Order a Coil choose Coil Ref + Voltage Code, example: 488143 for 200/50-60 = 488143P6

More voltage possibilities can be found in the table of voltage codes at the end of the coil section.

These coils must be used with suitable housings, see example below:

Please use the coil assembly kit Ref. 8993.

It is composed of a nameplate giving details of the valve type, a round washer and a nut to ensure the fixing between 22 mm coil and the valve.

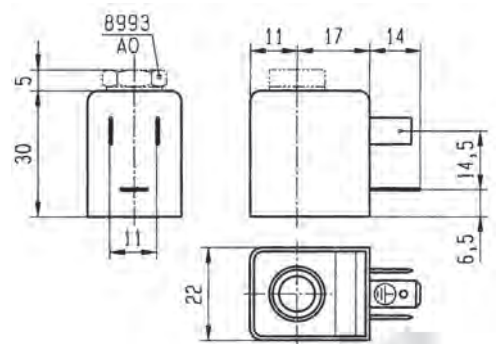

DOUBLE FREQUENCY COIL 22 mm

This coil can be mounted with every Parker solenoid valves corresponding to the specified Coil Group.

See column "Coil Group" within valve pages.

This coil is designed for valves equipped with a miniature tube assembly (2000 series valves). This is an encapsulated assembly comprising a coil, integral magnetic iron path and snap-on plug connection.

The synthetic material encapsulation provides an effective compact housing, offering full protection against dust, oil, water, etc.

Ease of mounting in confined space - offers shock and corrosion protection - simplifies conversion of existing equipment to other requirements, etc.

Coil conforms to the IEC/CENELEC safety standards and complies with European low-voltage directive.

DIN plug connector to be ordered separately (see coil accessories section).



Specification		Double frequency			
Reference (without DIN Plug)		496131			
Coil group		1.2			
Degree of protection		IP65 according to IEC / EN 60529 standards (with DIN plug).			
Class of insulation		F 155°C			
Electrical connection		The coil is connected with a 2 P + E plug according to EN 175301-803 type B.			
Ambient temperature		-40°C to +50°C The application is limited also by the temperature range of the valve.			
Elect. Power	DC	Pn (hot)	3 W		
		P (cold) 20°C	-		
	AC	Pn (holding)	3 W		
		Attraction cold	-		
Weight		60 g			
Voltages "Un"		VAC/Hz	Code	VDC	Code
-10% to +10% of the Un		24/50-60	P0	24 V	C2
		110/50-60	P2	48 V	C4
		230/50-60	P9	110 V	C5
		48/50-60	S4		

To Order a Coil choose Coil Ref + Voltage Code, example: 496131 for 24 VDC = 496131C2

More voltage possibilities can be found in the table of voltage codes at the end of the coil section.

"The housing kit is already included in the valve reference, it is not needed to order it separately."

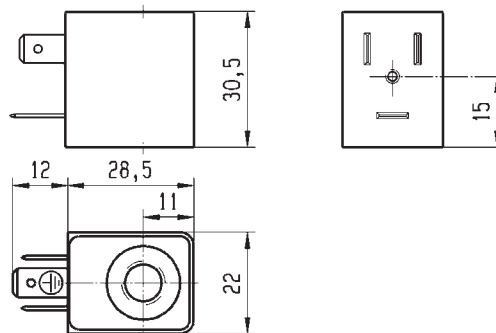

DOUBLE FREQUENCY COIL 22 mm

This coil can be mounted with every Parker solenoid valves corresponding to the specified Coil Group.
See column "Coil Group" within valve pages.

This coil is designed for valves equipped with a miniature tube assembly (2000 series valves). This is an encapsulated assembly comprising a coil, integral magnetic iron path and snap-on plug connection.

The synthetic material encapsulation provides an effective compact housing, offering full protection against dust, oil, water, etc.

Ease of mounting in confined space - offers shock and corrosion protection - simplifies conversion of existing equipment to other requirements, etc.

Coil conforms to the IEC/CENELEC safety standards and complies with European low-voltage directive.

DIN plug connector included.



Specification		Double frequency			
Reference		496482			
Coil group		1.2			
Degree of protection		IP65 according to IEC / EN 60529 standards (with DIN plug).			
Class of insulation		F 155°C			
Electrical connection		The coil is connected with a 2 P + E plug according to EN 175301-803 type B.			
Ambient temperature		-40°C to +50°C The application is limited also by the temperature range of the valve.			
Elect. Power	DC	Pn (hot)	3 W		
		P (cold) 20°C	-		
	AC	Pn (holding)	3 W		
		Attraction cold	-		
Weight		75 g			
Voltages "Un"		VAC/Hz	Code	VDC	Code
-10% to +10% of the Un		24/50-60	P0	24 V	C2
		110/50-60	P2	48 V	C4
		230/50-60	P9	110 V	C5
		48/50-60	S4		

To Order a Coil choose Coil Ref + Voltage Code, example: 496482 for 24 VDC = 496482C2

More voltage possibilities can be found in the table of voltage codes at the end of the coil section.

"The housing kit is already included in the valve reference, it is not needed to order it separately."

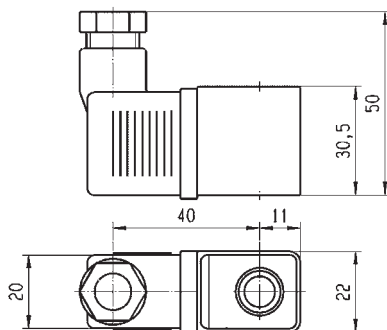

10.1

COILS FOR
DIN PLUG CONNECTION



COIL FOR OIL AND GAS 37 mm

This coil can be mounted with every Parker solenoid valves corresponding to the specified Coil Group.

See column "Coil Group" within valve pages.

This is an encapsulated assembly comprising a coil, integral magnetic iron path and snap-on plug connection.

The synthetic material encapsulation provides an effective compact housing, offering full protection against dust, oil, water, etc.

Ease of mounting in confined space - offers shock and corrosion protection - simplifies conversion of existing equipment to other requirements, etc.

Coils conform to the IEC/CENELEC safety standards and complies with European low-voltage directive. DIN plug connector included (The AC electrical connection is delivered with a rectifier bridge).



Specification		Coil for Oil and Gas			
Reference (with DIN plug)		496895			
Coil group		10.1			
Degree of protection		IP65 according to IEC / EN 60529 standards			
Class of insulation		H 180°C			
Electrical connection		With DIN plug 492459 (AC) or 486586 (DC)			
Ambient temperature		-40°C to +50°C The application is limited also by the temperature range of the valve.			
Elect. Power	DC	Pn (hot)	8 W		
		P (cold) 20°C	-		
	AC	Pn (holding)	8 W		
		Attraction cold	-		
Weight		273 g			
Voltages "Un" -10% to +10% of the Un		VAC/Hz	Code	VDC	Code
		230/50-60	P9	24	C2
		110/50-60	P2		

To Order a Coil choose Coil Ref + Voltage Code, example: 496895 for 24 VDC = 496895C2

More voltage possibilities can be found in the table of voltage codes at the end of the coil section.

The fixing nut (housing kit) is already included in the coil kit.

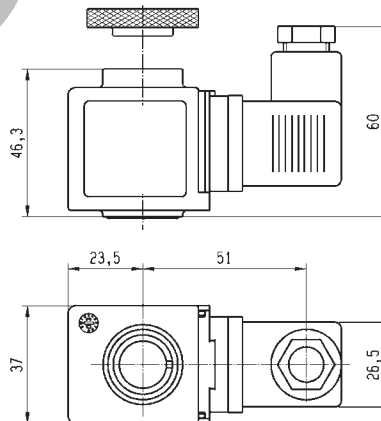

COIL 32 mm IP67

This coil can be mounted with every Parker solenoid valves corresponding to the specified Coil Group. See column "Coil Group" within valve pages.

This is an encapsulated assembly comprising a coil, integral magnetic iron path and snap-on plug connection.

The synthetic material encapsulation provides an effective compact housing, offering full protection against dust, oil, water, etc.

Ease of mounting in confined space - offers shock and corrosion protection - simplifies conversion of existing equipment to other requirements, etc.

Coils conform to the IEC/CENELEC safety standards and complies with European low-voltage directive.



Specification		Coil with two 500 mm flying leads			
Reference		496081			
Coil Group		2.0 / 2.1			
Degree of protection		IP67 according to IEC / EN 60529 standards			
Class of insulation		F 155°C			
Ambient temperature		-40 °C to +50°C The application is limited also by the temperature range of the valve.			
Elect. Power	DC	Pn (hot)	9 W		
		P (cold) 20°C	-		
	AC	Pn (holding)	9 W		
		Attraction cold	32 VA		
Weight		180 g			
Voltages "Un"		VAC/Hz	Code	VDC	Code
-10% to +10% of Un for AC		24/50 - 24/60	P0	24	C2
- 5 % to + 10 % for Un DC		110-115/50 - 120/60	S5	12	C1
		220-240/50 - 240/60	S6		

To Order a Coil: Coil Ref + Voltage Code, example: 496081 for 24 VDC = 496081C2

More voltage possibilities can be found in the table of voltage codes at the end of the coil section.



To assemble this coil on our solenoid valves, please order housing Ref: 2995

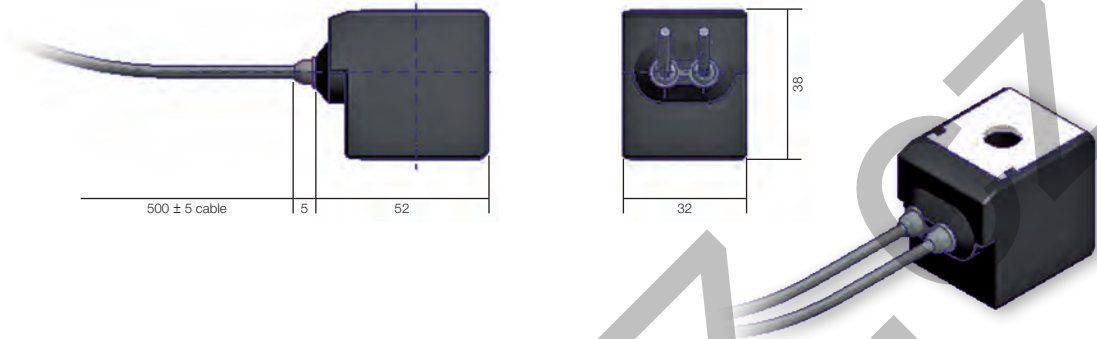

KOLVANZ

STANDARD COILS 40 mm

These coils can be mounted with every Parker Solenoid Valves corresponding to the specified Coil Group.

See column "Coil Group" within valve pages.

They can be mounted with all metal housings.

The coil winding is completely encapsulated in synthetic material.

Easy mounting in confined spaces. Electrical connection with screw terminals for wire up to 1.5 mm².

Coils conform to the IEC/CENELEC safety standards and complies with European low-voltage directive.



Specification		Standard			Double Frequency		
Reference		481000			483520		
Coil Group		2.0 / 2.1					
Class of insulation		F 155°C					
Ambient temperature		-40°C to +50°C					
The application is limited also by the temperature range of the valve.							
Elect. Power	DC	Pn (hot)	8W			-	
		P (cold) 20°C	9W			-	
	AC	Pn (holding)	8W			9W	
		Attraction cold	32 VA (9 W)			36 VA (10 W)	
Weight		130 g			130 g		
Voltages "Un"		VAC/Hz	Code	VDC	Code	VAC/Hz	Code
-10% to +10% of the Un		24/50	A2	24	C2	24/50-60	P0
(-15% to +5% for double-frequency coil with voltage code S6 if 240 V/50/Hz is used).		48/50	A4	48	C4	220-240/50-240/60	S6
		110/50-115/50	0A	110	C5		
		220/50-230/50	3D				

To Order a Coil choose Coil Ref + Voltage Code, example: 4828 for 24 VDC = 481000C2

More voltage possibilities can be found in the table of voltage codes at the end of the coil section.

These coils must be used with suitable housings, see examples below:

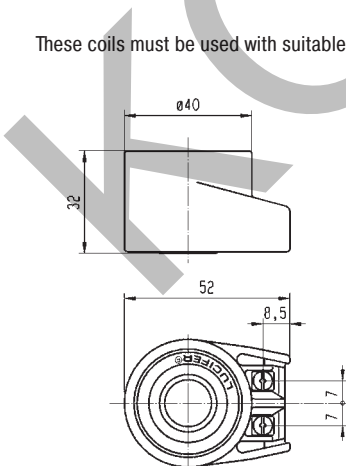

Ref. 4270 - Protection IP 44 according to IEC / EN 60529 standard (with cable gland)



Ref. 4538 - Protection IP 67 according to IEC / EN 60529 standard

HIGH POWER COILS 40 mm

This coil can be mounted with every Parker Solenoid Valves corresponding to the specified Coil Group.

See column "Coil Group" within valve pages.

They can be mounted with all metal housings.

The coil winding is completely encapsulated in synthetic material.

Easy mounting in confined spaces. Electrical connection with screw terminals for wire up to 1.5 mm².

Coils conform to the IEC/CENELEC safety standards and complies with European low-voltage directive.



Specification		High Power	
Reference		481044	
Coil Group		2.0 / 2.2	
Class of insulation		F 155°C	
Ambient temperature		-40°C to +50°C The application is limited also by the temperature range of the valve.	
Elect. Power	DC	Pn (hot)	-
		P (cold) 20°C	-
	AC	Pn (holding)	14 W
		Attraction cold	56 VA (20 W)
Weight		130 g	
Voltages "Un"		VAC/Hz	Code
-10% to +10% of the Un		24/50	A2
		220/50	A7
		230/50	F4

To Order a Coil choose Coil Ref + Voltage Code, example: 481044 for 24VAC/50Hz = 481044A2

More voltage possibilities can be found in the table of voltage codes at the end of the coil section.

These coils must be used with suitable housings, see examples below:

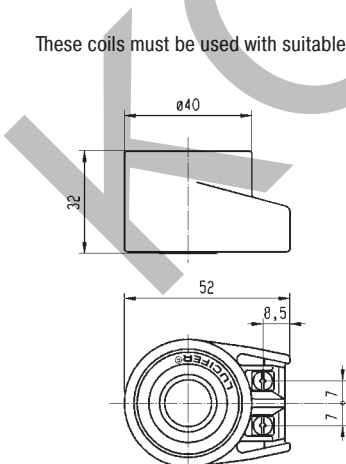

Ref. 4270 - Protection IP 44 according to IEC / EN 60529 standard (with cable gland)



Ref. 4538 - Protection IP 67 according to IEC / EN 60529 standard

HIGH TEMPERATURE COILS 40 mm

These coils can be mounted with every Parker Solenoid Valves corresponding to the specified Coil Group.

See column "Coil Group" within valve pages.

They can be mounted with all metal housings.

The coil winding is completely encapsulated in synthetic material.

Easy mounting in confined spaces. Electrical connection with screw terminals for wire up to 1.5 mm².

Coils conform to the IEC/CENELEC safety standards and complies with European low-voltage directive.



Specification		High Temperature & High Power			
Reference		486265			
Coil Group		2.0 / 2.2			
Class of insulation		H 180°C			
Ambient temperature		-40°C to +50°C The application is limited also by the temperature range of the valve.			
Elect. Power	DC	Pn (hot)	14 W		
		P (cold) 20°C	21 W		
	AC	Pn (holding)	14 W		
		Attraction cold	56 VA (20 W)		
Weight		140 g			
Voltages "Un"		VAC/Hz	Code	VDC	Code
-10% to +10% of the Un		24/50	A2	12	C1
		110/50	A5	24	C2
		220/50	A7	48	C4
		230/50	F4		

To Order a Coil choose Coil Ref + Voltage Code, example: 486265 for 24VAC/50Hz = 486265

More voltage possibilities can be found in the table of voltage codes at the end of the coil section.

These coils must be used with suitable housings, see examples below:

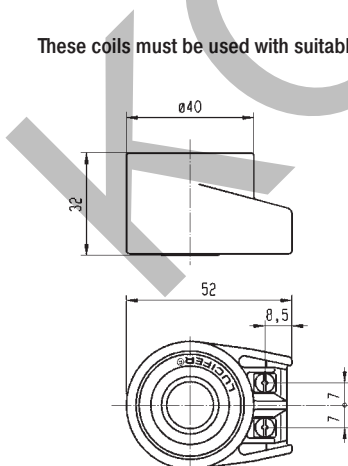

Ref. 4270 - Protection IP 44 according to IEC / EN 60529 standard (with cable gland)



Ref. 4538 - Protection IP 67 according to IEC / EN 60529 standard

HIGH TEMPERATURE & HIGH POWER COILS 40 mm OIL BURNER

This coils can be mounted with every Parker Solenoid Valves corresponding to the specified Coil Group.

See column "Coil Group" within valve pages.

It can be mounted with all metal housings.

The coil winding is completely encapsulated in synthetic material.

Easy mounting in confined spaces. Electrical connection with screw terminals for wire up to 1.5 mm².

Coil conform to the IEC/CENELEC safety standards and complies with European low-voltage directive.

This coil is used only in safety application according to DIN/EN/ISO 23551-1:2009-10 (Oil burners)



Specification		High Temperature & High Power	
Reference		483824	
Coil Group		14.1	
Class of insulation		H 180°C	
Ambient temperature		-40°C to +50°C The application is limited also by the temperature range of the valve.	
Elect. Power	DC	Pn (hot)	19 W
		P (cold) 20°C	19 W
	AC	Pn (holding)	19 W
		Attraction cold	56 VA (20 W)
Weight		130 g	
Voltages "Un"		VAC/Hz	Code
-10% to +10% of the Un		120/50	A6
		240/50	A8
		110/60	B5
		220/60	B7
		58/50-60/60	T6
		55/60	4J

To Order a Coil choose Coil Ref + Voltage Code, example: 483824 for 120/50 = 483824A6

More voltage possibilities can be found in the table of voltage codes at the end of the coil section.

These coils must be used with suitable housings, Ref: 8760.24 and Ref: 8520.23

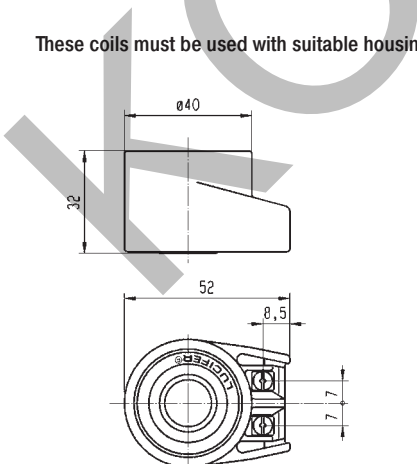

Ref. 8760.24



Ref. 8520.23

HIGH TEMPERATURE & HIGH POWER COILS 40 mm OIL BURNER

This coils can be mounted with every Parker Solenoid Valves corresponding to the specified Coil Group.

See column "Coil Group" within valve pages.

It can be mounted with all metal housings.

The coil winding is completely encapsulated in synthetic material.

Easy mounting in confined spaces. Electrical connection with screw terminals for wire up to 1.5 mm².

Coil conform to the IEC/CENELEC safety standards and complies with European low-voltage directive.

This coil is used only in safety application according to DIN/EN/ISO 23551-1:2009-10 (Oil burners)



Specification		High Temperature & High Power	
Reference		483541	
Coil Group		14.3	
Class of insulation		H 180°C	
Ambient temperature		-40°C to +50°C The application is limited also by the temperature range of the valve.	
Elect. Power	DC	Pn (hot)	20 W
		P (cold) 20°C	20 W
	AC	Pn (holding)	20 W
		Attraction cold	56 VA (20 W)
Weight		130 g	
Voltages "Un"		VAC/Hz	Code
-10% to +10% of the Un		120/50	A6
		240/50	A8
		110/60	B5
		220/60	B7
		58/50-60/60	T6
		55/60	4J

To Order a Coil choose Coil Ref + Voltage Code, example: 483541 for 120/50 = 483541A6

More voltage possibilities can be found in the table of voltage codes at the end of the coil section.

These coils must be used with suitable housings, Ref: 8760.24 and Ref: 8520.23

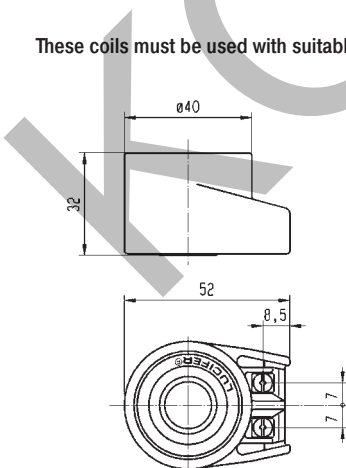

Ref. 8760.24



Ref. 8520.23

COIL DOUBLE FREQUENCY 40 mm H CLASS

This coil can be mounted with every Parker Solenoid Valves corresponding to the specified Coil Group.

See column "Coil Group" within valve pages.

They can be mounted with all metal housings.

The coil winding is completely encapsulated in synthetic material.

Easy mounting in confined spaces. Electrical connection with screw terminals for wire up to 1.5 mm².

Coils conform to the IEC/CENELEC safety standards and complies with European low-voltage directive.



Specification		Double Frequency 100 V - 200 V	
Reference		488553	
Coil Group		2.0/2.1	
Class of insulation		H 180°C	
Ambient temperature		-40°C to +50°C The application is limited also by the temperature range of the valve.	
Elect. Power	DC	Pn (hot)	-
		P (cold) 20°C	-
	AC	Pn (holding)	9 W
		Attraction cold	-
Weight		130 g	
Voltages "Un"		VAC/Hz	Code
-10% to +10% of the Un		100/50-60	P1
		200/50-60	P6

To Order a Coil choose Coil Ref + Voltage Code, example: 488553 for 110/50-60 = 488553P1

More voltage possibilities can be found in the table of voltage codes at the end of the coil section.

These coils must be used with suitable housings, see examples below:

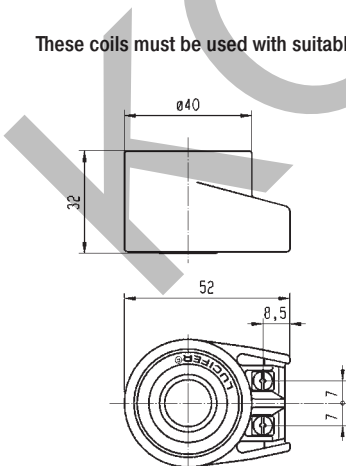

Ref. 4270 - Protection IP 44



Ref. 8520 - Protection IP 54

BISTABLE COILS 40 mm FOR IMPULSE APPLICATIONS

These coils can be mounted with every Parker solenoid valves corresponding to the specified Coil Group.

See column "Coil Group" within valve pages.

These coils are specially designed for Lucifer® bistable (or impulse or magnetic latch) solenoid valves for Heating Applications.

They can be mounted only with the Lucifer® metallic housing 4269 or 4538.

The coil winding is completely encapsulated in synthetic material.

Easy mounting in confined spaces. Electrical connection with screw terminals for wire up to 1.5 mm².

Coils conform to the IEC/CENELEC safety standards and complies with European low-voltage directive.



Specification		Bistable (Impulse)			
Reference		484990		485400	
Coil Group		4.0			
Class of insulation		F 155°C			
Ambient temperature		-40°C to +50°C			
		The application is limited also by the temperature range of the valve.			
Length of impulses		Switch on (terminals A-B): minimum 50 ms Switch off (terminals A-C): minimum 35 ms			
Electr. Power consumption	DC				
	Attraction (hot)	-		13 W	
	Attraction (cold)	-		19 W	
	Release (hot)	-		8 W	
	Release (cold)	-		10 W	
	AC				
	Attraction (hot)	11 W		-	
	Attraction (cold)	17 W		-	
Release (hot)	4 W		-		
Release (cold)	7 W		-		
Weight		150 g			
Voltages "Un"		VAC/Hz	Code	VDC	Code
-10% to +10% of the Un		24/50-24/60	P0	24	C2
		110-115/50-115/60	1P	48	C4
		220-230/50-60	3P	110	C5

To Order a Coil choose Coil Ref + Voltage Code, example: 485400 for 24 VDC = 485400C2

More voltage possibilities can be found in the table of voltage codes at the end of the coil section.

These coils must be used with suitable housings, see examples below:

DIAGRAM

Alternating Current

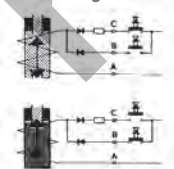

Direct Current

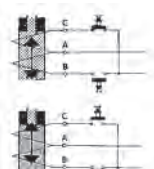

Only an electrical impulse given to terminals A-C reverses the magnetic field. This magnetic field demagnetises the reversible magnet enough to allow the return spring to bring the plunger back to its initial position and close the valve.

Ref. 4269 - Protection IP 44

Ref. 4538 - Protection IP 67



COILS 12 V - 24 V FOR TRANSPORTATION APPLICATIONS 32 mm

These coils can be mounted with every Parker solenoid valves corresponding to the specified Coil Group. See column "Coil Group" within valve pages.

These coils are specially designed for Lucifer® solenoid valves for Transportation Applications.

They can be mounted with the standard Lucifer® housing 2161 or customized housing.

The coil winding is completely encapsulated in epoxy. Easy mounting and dismantling in confined spaces. Bayonet twist and lock coupling for tight, vibration resistant connection.

Coils conform to the IEC/CENELEC safety standards and complies with European low-voltage directive.



Specification		Transportation			
Reference		496193 with diode		495294 without diode	
Coil Group		13.0			
Degree of protection		IP69K for DIN 400050 part 9			
Ambiant temperature		- 40°C to +120°C The application is limited also by the temperature range of the valve and duty cycle of the valve.			
Insulation Class		F 155°C			
Electrical connection		ISO 15170-A1-2.3-Sn/K2		DIN 72585-A3-2.1	
Elect. Power	DC	Pn (hot)		9 w	
		P (cold) 20°C		-	
	AC	Pn (holding)		-	
		Attraction cold		-	
Weight		147 g			
Voltages "Un"	VDC	Code	VDC	Code	
- 30% to + 30% of the Un	12	C1	12	C1	
	24	C2	24	C2	

To Order a Coil choose Coil Ref + Voltage Code, example: 496193 for 24 VDC = 496193C2

These coils must be used with suitable housings Ref.2168 for 12Vdc and 2169 for 24 VDC.

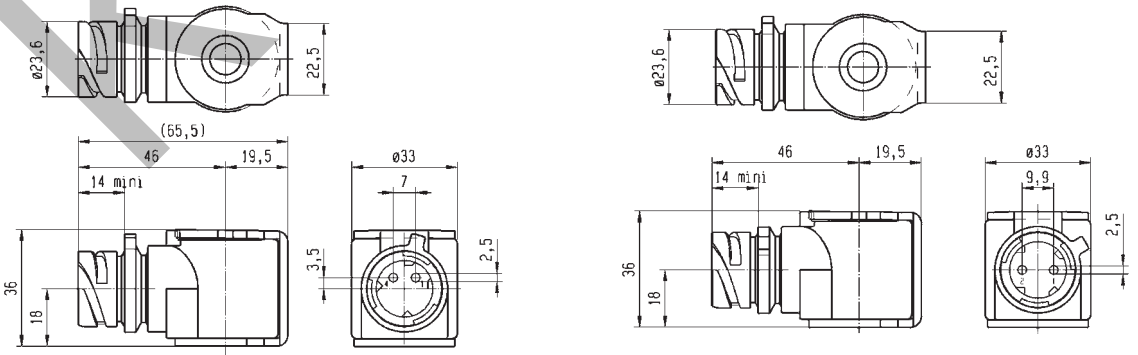

KOVANZ.CZ

TABLE OF CONTENT

INTRODUCTION

Index for Explosion Proof Electrical Parts	414
List of Coil Groups	411

COILS

Coils for DIN plug connection	418
Coils with flying leads	432
Coils with screw terminal	434
Coils with ISO-DIN connector	441

EXPLOSION PROOF ELECTRICAL PARTS

Level of protection "nAc nCc"	445
Level of protection "db"	452
Level of protection "mb"	453
Level of protection "db mb"	457
Level of protection "eb"	462
Level of protection "eb mb"	463
Level of protection "ia"	466

HOUSINGS	474
----------------	-----

COIL ACCESSORIES	478
------------------------	-----

EXPLOSIVE ENVIRONMENTS	480
------------------------------	-----

COIL APPENDICES

Guidance chart for IS-Barriers	490
--------------------------------------	-----



ZONE 2/22

ELECTRICAL PART LOW POWER 22 mm

This coil can be mounted with every Parker ATEX solenoid valves corresponding to the specified Coil Group.

See column "Coil Group" within valve pages.

Application:

Control of solenoid valves in dangerous areas where explosion-proof protection Ex nAc nCc IIC T5 is required.

Benefits:

The synthetic material encapsulation of the coil provides an effective compact housing, offering full protection against dust, oil, water, etc. Small size for ease of mounting in confined spaces.



Reference		495865			
Certificate		LCIE 05 ATEX 6003 X			
Coil Group		1.1			
Type of protection	Gas	II 3 G Ex nAc nCc IIC T5			
	Dust	II 3 D - Ex tc IIIC - T 95°C			
Degree of protection		IP65 (with plug) according to IEC/EN 60529 Standards			
Ambiant temperature		-40°C to +50°C The application is limited also by the temperature range of the valve.			
Insulation Class		F 155°C			
Electrical connection		These coils with connection 2P + G - when mounted together with the supplied Pg 9 plug (delivered with the coil),			
Elect. Power	DC	Pn (hot)	2.5 W		
		P (cold) 20°C	3 W		
	AC	Pn (holding)	2 W		
		Attraction cold	5.7 VA (2.5 W)		
Weight		120 g			
Voltages "Un"		VAC/Hz	Code	VDC	Code
-10% to +10% of the Un		24/50	A2	24	C2
		110/50-115/50	0A		
		220/50-230/50	3D		

To Order a Coil choose Coil Ref + Voltage Code, example: 495865 for 24 VDC = 495865C2

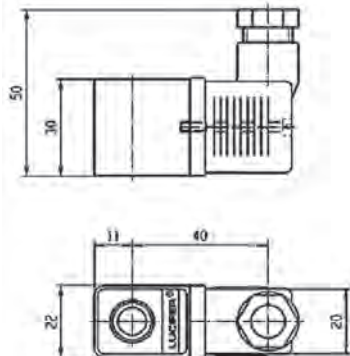



ELECTRICAL PART DOUBLE FREQUENCY 22 mm

This coil can be mounted with every Parker ATEX solenoid valves corresponding to the specified Coil Group.

See column "Coil Group" within valve pages.

Application:

Control of solenoid valves in dangerous areas where explosion-proof protection Ex nAc nCc IIC T5 is required.

Benefits:

The synthetic material encapsulation of the coil provides an effective compact housing, offering full protection against dust, oil, water, etc. Small size for ease of mounting in confined spaces.



ZONE 2/22

Specification		Double Frequency			
Reference		496637			
Certificate		ATEX			
Coil group		1.2			
Type of protection	Gas	Ex nAc nCc IIC T5			
	Dust	II 3 D - Ex tc IIIC - T 95°C			
Degree of protection		IP65 (with plug) according to IEC/EN 60529 Standards			
Ambiant temperature		-40°C to +50°C The application is limited also by the temperature range of the valve.			
Insulation Class		F 155°C			
Elect. Power	DC	Pn (hot)	3 W		
		P (cold) 20°C	-		
	AC	Pn (holding)	3 W		
		Attraction cold	5.7 VA (2.5 W)		
Weight		75 g			
Voltages "Un"		VAC/Hz	Code	VDC	Code
-10% to +10% of the Un		24/50-60	P0	24 V	C2
		110/50-60	P2	48 V	C4
		230/50-60	P9	110 V	C5
		48/50-60	S4		

To Order a Coil choose Coil Ref + Voltage Code, example: 496637 for 24 VDC = 496637C2

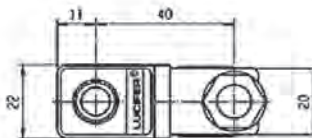
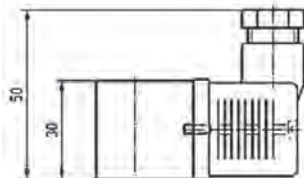



ZONE 2/22

ELECTRICAL PART 32 mm

These coils can be mounted with every Parker ATEX solenoid valves corresponding to the specified Coil Group.
See column "Coil Group" within valve pages.

Application: Control of solenoid valves in dangerous areas where explosion-proof protection Ex nAc nCc IIC T3/T4 is required.

Ease of mounting in confined space - offers shock and corrosion protection- simplifies conversion of existing equipment to other requirements, etc.

Benefits:

The synthetic material encapsulation of the coil provides an effective compact housing, offering full protection against dust, oil, water, etc.

Small size for ease of mounting in confined spaces.



Reference		495870			496110		
Certificate		LCIE 05 ATEX 6003 X					
Coil Group		2.0 / 2.1					
Type of protection	Gas	II 3 G Ex nAc nCc IIC T3/T4			II 3 G Ex nAc nCc IIC T3/T4		
	Dust	II 3 D - Ex tc IIIC - T195°C / T130°C			II 3 D - Ex tc IIIC - T195°C / T130°C		
Degree of protection		IP65 (with plug) according to IEC/EN 60529 Standards					
Insulation Class		F (155°C)					
Duty cycle		100%					
Ambient temperature		-40°C to +65°C / 50°C The application is limited also by the temperature range of the valve.					
Elect. Power	DC	Pn (hot)	9 W			-	
		P (cold) 20°C	12 W			-	
	AC	Pn (holding)	8 W			9 W	
		Attraction cold	26 VA (9 W)			32 VA (10 W)	
Weight		150 g					
Voltages "Un" -10% to +10% of the Un	VAC/Hz	Code	VDC	Code	VAC/Hz	Code	
	24/50	A2	24	C2	24/50-60	P0	
	48/50	A4	48	C4			
	110/50	A5	110	C5	110/50-60	S5	
	220-230/50	3D			220/50-60	S6	

To Order a Coil choose Coil Ref + Voltage Code, example: 495870 for 24 VDC = 495870C2

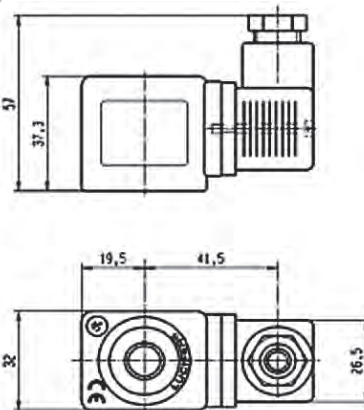



ELECTRICAL PART LOW POWER 32 mm

This coil can be mounted with every Parker ATEX solenoid valves corresponding to the specified Coil Group.
See column "Coil Group" within valve pages.

Application: Control of solenoid valves in dangerous areas where explosion-proof protection Ex nAc nCc IIC T5/T6 is required.

Ease of mounting in confined space - offers shock and corrosion protection- simplifies conversion of existing equipment to other requirements, etc.

Benefits:

The synthetic material encapsulation of the coil provides an effective compact housing, offering full protection against dust, oil, water, etc.

Small size for ease of mounting in confined spaces.



ZONE 2/22

Reference	496125		
Certificate	LCIE 05 ATEX 6003 X		
Coil group	6.0		
Type of protection	Gas	II 3 G Ex nAc nCc IIC T5/T6	
	Dust	II 3 D Ex tc IIC T95°C/80°C	
Degree of protection	IP65 (with plug) according to IEC/EN 60529 Standards		
Insulation Class	F (155°C)		
Duty cycle	100%		
Ambient temperature	-40°C to +65°C / 50°C The application is limited also by the temperature range of the valve.		
Elect. Power	DC	Pn (hot)	1.6 W
		P (cold) 20°C	2.1 W
	AC	Pn (holding)	-
		Attraction cold	-
Weight	150 g		
Voltages "Un"	VDC	Code	
-10% to +10% of the Un	24	C2	

To Order a Coil choose Coil Ref + Voltage Code, example: 496125 for 24 VDC = 496125C2

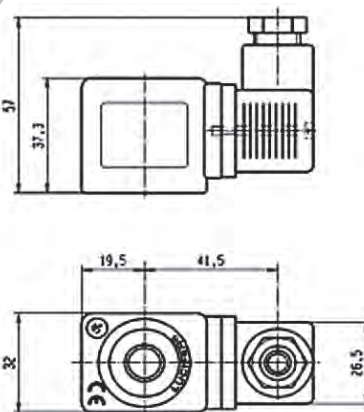

ZONE 2/22

ELECTRICAL PART 32 mm

These coils can be mounted with every Parker ATEX solenoid valves corresponding to the specified Coil Group.
See column "Coil Group" within valve pages.

Application: Control of solenoid valves in dangerous areas where explosion-proof protection Ex nAc nCc IIC T3/T4 is required.

Ease of mounting in confined space - offers shock and corrosion protection- simplifies conversion of existing equipment to other requirements, etc.

Benefits:

The synthetic material encapsulation of the coil provides an effective compact housing, offering full protection against dust, oil, water, etc.
Small size for ease of mounting in confined spaces.



Specification		32 mm Coil "nAc nCc"			
Reference		495875			
Certificate		LCIE 05 ATEX 6003 X			
Coil Group		3.0			
Type of protection	Gas	II 3 G Ex nAc nCc IIC T3/T4			
	Dust	II 3 D - Ex tc IIIC - T195°C / T130°C			
Degree of protection		IP65 (with plug) according to IEC/EN 60529 Standards			
Insulation Class		F 155°C			
Duty cycle		100%			
Ambiant temperature		-40°C to +65°C / 50°C The application is limited also by the temperature range of the valve.			
Elect. Power	DC	Pn (hot)	7 W		
		P (cold) 20°C	-		
	AC	Pn (holding)	6 W		
		Attraction cold	-		
Weight		180 g			
Voltages "Un"		VAC/Hz	Code	VDC	Code
-10% to +10% of the Un		220-230/50	3D	24	C2

To Order a Coil choose Coil Ref + Voltage Code, example: 495875 for 24 VDC = 495875C2

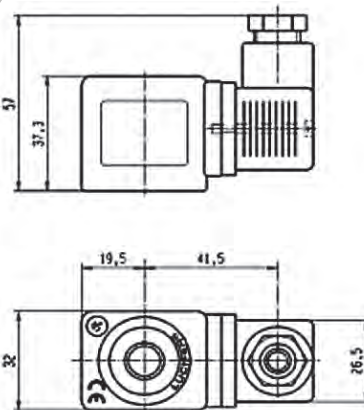

COIL GROUP

2.0/2.2

**NON ENCAPSULATED
ELECTRICAL PARTS
"nAc nCc"**



ELECTRICAL PART 32 mm

This coil can be mounted with every Parker ATEX solenoid valves corresponding to the specified Coil Group.
See column "Coil Group" within valve pages.

Application: Control of solenoid valves in dangerous areas where explosion-proof protection Ex nAc nCc IIC T3 is required.

Ease of mounting in confined space - offers shock and corrosion protection - simplifies conversion of existing equipment to other requirements, etc.

Benefits:

The synthetic material encapsulation of the coil provides an effective compact housing, offering full protection against dust, oil, water, etc.

Small size for ease of mounting in confined spaces.



ZONE 2/22

Specification		32 mm Coil "nAc nCc"			
Reference		495880			
Certificate		LCIE 05 ATEX 6003X			
Coil Group		2.0 / 2.2			
Type of protection	Gas	II 3 G Ex nAc nCc IIC T3			
	Dust	II 3 D - Ex tc IIIC - T195°C			
Degree of protection		IP65 (with plug) according to IEC/EN 60529 Standards			
Insulation Class		H 180°C			
Duty cycle		100%			
Ambiant temperature		-40°C to +65°C The application is limited also by the temperature range of the valve.			
Elect. Power	DC	Pn (hot)	14 W		
		P (cold) 20°C	-		
	AC	Pn (holding)	14 W		
		Attraction cold	-		
Weight		180 g			
Voltages "Un"		VAC/Hz	Code	VDC	Code
-10% to +10% of the Un		24/50	A2	24	C2
		110/50	A5		
		230/50	F4		

To Order a Coil choose Coil Ref + Voltage Code, example: 495880 for 24 VDC = 495880C2

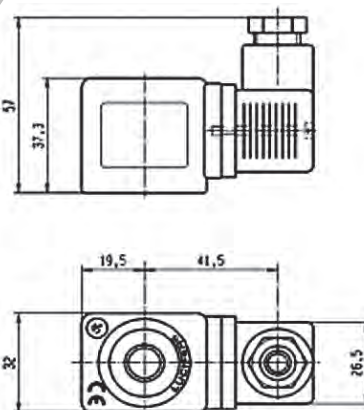



ZONE 2/22

495915 - ELECTRICAL PARTS 50 mm

This coil can be mounted with every Parker ATEX solenoid valves corresponding to the specified Coil Group.
See column "Coil Group" within valve pages.

Application: Control of solenoid valves in dangerous areas where explosion-proof protection - Ex nAc nCc IIC T3 is required.

Benefits: Rotatable housing 360°, epoxy varnished steel with internal and external screw terminals for earth connection.

Small size for ease of mounting in confined space. Simplifies conversion of existing equipment to hazardous area requirements.



Reference		495915		
Certificate		LCIE 05 ATEX 6010 X		
Coil group		4.0		
Type of protection	Gas	II 3 G Ex nAc nCc IIC T3		
	Dust	II 3 D - Ex tc III C - T 195°C		
Degree of protection		IP67 according to IEC/EN 60529 Standards		
Ambient temperature		-40°C to +65°C The application is limited also by the temperature range of the valve.		
Insulation Class		F 155°C		
Electrical connection		By special cable gland M20 x 1.5 on screw terminals for wires up to 1.5 mm². Cable with outside diameter 6.5 mm to 13.5 mm can be simply sealed using the rubber gland with resilient sealing rings supplied		
Consumption Electrique	AC	Attraction (hot)	11 W	-
		Attraction (cold) 20°C	17 W	-
		Release (hot)	4 W	-
		Release (cold) 20°C	7 W	-
	DC	Attraction (hot)	-	13 W
		Attraction (cold) 20°C	-	19 W
		Release (hot)	-	8 W
		Release (cold) 20°C	-	10 W
Weight		320 g		
Duty cycle		Continuous duty solenoid (ED 100%)		
Voltages "Un"		VAC/Hz	Code	VDC
-10% to +10% of the Un		110-115/50-60 220-230/50-60 48/50-60 24/50-60	1P 3P S4 P0	24 48 C2 C4

To Order a Coil choose Coil Ref + Voltage Code,
example: 495915 for 24 VDC = 495915C2

Schema

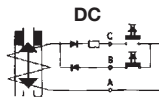
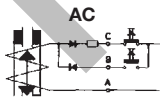

As soon as an electrical impulse is given to the terminals A-B, the electromagnet force attracts the plunger and simultaneously magnetizes a reversible permanent magnet ring. This magnet retains the plunger in place. It stays in position even without current. Only an electrical impulse given to terminals A-C reserves the magnetic field. This magnetic field demagnetizes the reversible magnet enough to allow the return spring to bring the plunger back to its initial position and close the valve.

Switch: Switch on (terminals A-B): Minimum 50 ms (maximum 1 s)
AC: Switch off (terminals A-C): Minimum 35 ms (maximum 1 s)

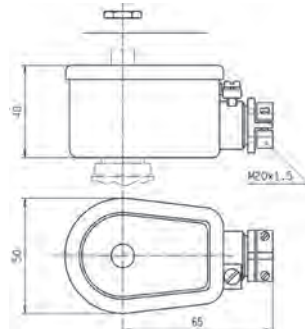

COIL GROUP

2.0/2.2

**INCREASED SAFETY
ELECTRICAL PARTS
"nAc nCc"**



3.5.1 ELECTRICAL PARTS 496155

These coils can be mounted with every Parker solenoid valves corresponding to the specified Coil Group.

See column "Coil Compatibility Group" within valve pages.

Application: Control of solenoid valves in dangerous areas where explosion-proof protection Ex nAc nCc IIC T3 is required.

Benefits: Rotatable housing 360°, epoxy varnished steel with internal and external screw terminals for earth connection.

Small size for ease of mounting in confined space. Simplifies conversion of existing equipment to hazardous area requirements.



ZONE 2/22

Reference		496155			
Certificate		LCIE 05 ATEX 6010 X			
Coil Group		2.0/2.2			
Type of protection	Gas	II 3 G Ex nAc nCc IIC T3			
	Dust	II 3 G D - Ex tc IIC - T 195 °C			
Degree of protection		IP67 according to IEC/EN 60529 Standards			
Ambiant temperature		-40°C to +65°C The application is limited also by the temperature range of the valve.			
Insulation Class		H 180°C			
Electrical connection		By special cable gland or M20x1.5 on screw terminals for wires up to 1.5 mm ² . Cables with outside diameter 6.5 mm to 13.5 mm can be simply sealed using the rubber gland with resilient sealing rings supplied.			
Elect. Power	DC	Pn (hot)	14 W		
		P (cold) 20°C	21 W		
	AC	Pn (holding)	14 W		
		Attraction cold	56 VA (20 W)		
Weight		320 g			
Voltages "Un"		VAC/Hz	Code	VDC	Code
-10% to +10% of the Un		24/50	A2	24	C2
		230/50	F4		

To Order a Coil choose Coil Ref + Voltage Code, example: 496155 for 24VAC/50Hz = 496155A2

Fuses:

Both electrical parts have to be connected in series with a safety fuse according to IEC 60127-3.

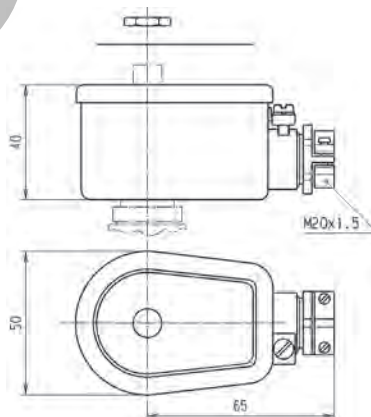

497105 & 497105.02 - ELECTRICAL PARTS

These coils can be mounted with every Parker ATEX solenoid valves corresponding to the specified Coil Group.

See column "Coil Group" within valve pages.

Application: Control of solenoid valves in dangerous areas where explosion-proof protection Ex db IIC T4 / T5 / T6 is required.

Benefits: Rotatable 360°, stainless steel with internal and external screw terminals for earth connection.

Small size for ease of mounting in confined space. Simplifies conversion of existing equipment to hazardous area requirements.



Reference	497105 (M20x1.5) 497105.02 (NPT 1/2")			
Certificate	INERIS 12ATEX0041X - IECEx INE 12.0034X			
Coil Group	10.3			
Type of protection	Gas	II 2 G - Ex db IIC T4 / T5 / T6		
	Dust	II 2 D - Ex tb IIIC - 130°C / 95°C / 80°C		
Degree of protection	IP66 (with relevant cable gland) according to IEC/EN 60529 Standards			
Ambient temperature	-50°C to +80°C / +60°C / +40°C The operating temperature of the valve/coil can be limited by that of the valve			
Insulation Class	H 180°C			
Electrical connection	Electric connection is done in the connection chamber on an easily accessible connector terminals. The cable entry to the connection chamber is made through a 1/2" NPT or M20x1.5 thread in which an approved Exdb IIC cable gland must be installed.			
Electrical consumption	DC	Pn (hot)	8 W	
		P (cold) 20°C	9 W	
	AC	Pn (holding)	8 W	
		Attraction cold	9 W	
Voltage Tolerance	+/- 10% of nominal voltage			
Emerging Cuty	ED 100%			
Voltages	VAC/Hz	Code	VDC	Code
	24/50-60	P0	12	C1
	110-115 / 50-60	1P	24	C2
	220-230 / 50-60	3P	48	C4
			110	C5

To Order a Coil choose Coil Ref + Voltage Code, example: 497105 for 24 VDC = 497105C2

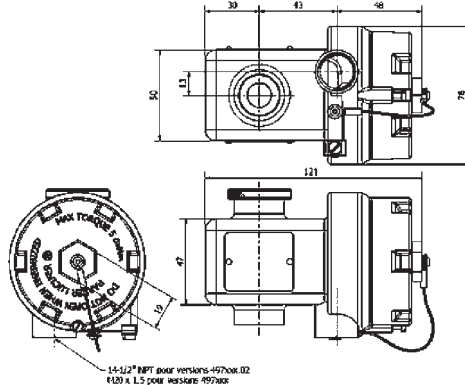

COIL GROUP

1.1

**ENCAPSULATED
ELECTRICAL PARTS
"mb"**



ZONE 1/21

ELECTRICAL PART LOW POWER 22 mm

These coils can be mounted with every Parker ATEX solenoid valves corresponding to the specified Coil Group.
See column "Coil Group" within valve pages.

Application:

Control of solenoid valves in dangerous areas where explosion-proof protection Ex mb IIC T4 / T5 is required.

Benefits:

Coil and magnetic circuit encapsulated in synthetic material - offering shock and corrosion protection. AC coils with integrated thermal fuse. Small size for ease of mounting in confined spaces.



Reference	482605		482606 or 482606.160*			
Certificate	LCIE 02 ATEX 6014 X - IECEX LCI 07.0026 X					
Coil Group	1.1					
Type of protection	Gas	II 2 G - Ex mb IIC T4 / T5				
	Dust	II 2 D - Ex tb IIIC - T130°C / 95°C				
Degree of protection	IP65 (with plug) according to IEC/EN 60529 Standards					
Ambiant temperature	-40°C to +65°C / +40°C			-40°C to +65°C / +35°C		
	The application is limited also by the temperature range of the valve.					
Insulation Class	F 155°C					
Electrical connection	Cable connection (3 x 0.75 mm ²) encapsulated with coil, cable material according to application					
Elect. Power	DC	Pn (hot)	5 W	2.5 W		
		P (cold) 20°C	6.5 W	3 W		
	AC	Pn (holding)	4 W	2 W		
		Attraction cold	8.9 VA (5 W)	5.7 VA (2.5 W)		
Weight	150 g					
Voltagess "Un"	VDC	Code	VAC/Hz	Code	VDC	Code
-10% to +10% of the Un	12	C1	24/50	A2	24	C2
	24	C2	48/50	A4	48	C4
			110/50-115/50	0A	110	C5
			220/50-230/50	3D		

To Order a Coil choose Coil Ref + Voltage Code, example: 482605 for 24 VDC = 482605C2

* 482606.160 - 6 m cable length - available only in C2 and 3D

* 482606 - 1.5 m cable length

Fuses:

Both electrical parts 482605 & 482606 have to be connected in series with a safety fuse according to CEI 60127-3. Indicating example below:

482605:

DC: 12 V, 1000 mA - 24 V, 500 mA

482606:

DC: 12 V, 400 mA - 24 V, 200 mA - 48 V, 100 mA - 110 V, 50 mA
AC 50 Hz: 24 V, 250 mA - 48 V, 125 mA - 110/115 V, 63 mA - 220/230 V, 32 mA
AC 60 Hz: 24 V, 315 mA - 110/115 V, 63 mA - 220/230 V, 32 mA

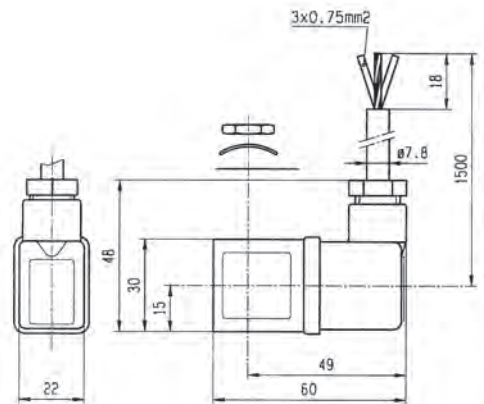

COIL GROUP

2.0/2.1

**ENCAPSULATED
ELECTRICAL PARTS
"mb"**



ZONE 1/21

WITH WATER PROOF METAL HOUSING 50 mm

These coils can be mounted with every Parker ATEX solenoid valves corresponding to the specified Coil Group.

See column "Coil Group" within valve pages.

Application: Control of solenoid valves in dangerous areas where explosion-proof protection Ex mb IIC T4/ T5 is required.

Benefits: Epoxy-vernished steel housing - solenoid coil, rectifier (silicium diodes), fuse and varistor protection element are completely encapsulated in the coil housing by means of epoxy resin.

Small size for ease of mounting in confined space. Simplifies conversion of existing equipment to hazardous area requirements.



Reference	492070 (with 3 m cable length) 492070.60 (with 6 m cable length)			
Certificate	LCIE 02 ATEX 6017 X - IECEx LCI 09.0024 X			
Coil Group	2.0 / 2.1			
Type of protection	Gas	II 2 G - Ex mb IIC T4/ T5		
	Dust	II 2 D - Ex tb IIIC - T130 / 95°C		
Degree of protection	IP67 according to IEC/EN 60529 standards			
Ambient temperature	-40°C to +65°C / 40°C The application is limited also by the temperature range of the valve.			
Insulation Class	H 180°C			
Electrical connection	Cable connection (3 x 1.5 mm ²) with cable gland M20 x 1.5, external earth screw connection.			
Elect. Power	DC	Pn (hot)	8 W	
		P (cold) 20°C	10 W	
	AC	Pn (holding)	9 W	
		Attraction cold	11 W	
Weight	500 g			
Voltages "Un"	VAC/Hz	Code	VDC	Code
-10% to +10% of the Un	24/50-60	P0	24	C2
	110/50-60	P2	48	C4
	220/50-60	R5	110	C5
	230/50-60	P9		
	240/50-60	Q1		

To Order a Coil choose Coil Ref + Voltage Code, example: 492070 for 24 VDC = 492070C2

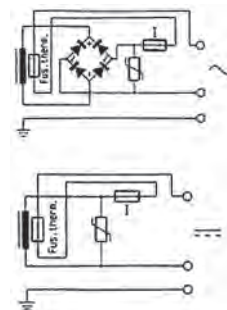
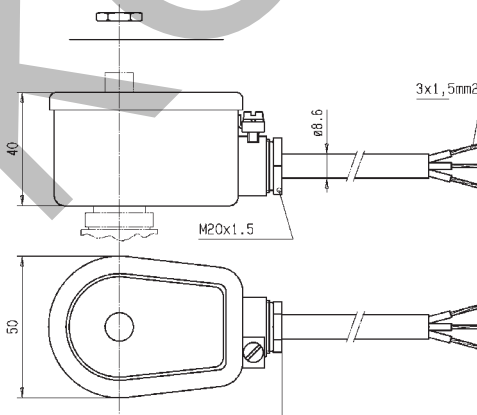

COIL GROUP

2.0/2.1

**ENCAPSULATED
ELECTRICAL PARTS
"mb"**



ZONE 1/21

HZ10 COIL DOUBLE FREQUENCY

This coil can be mounted with every Parker ATEX solenoid valves corresponding to the specified Coil Group.
See column "Coil Group" within valve pages.

Application: Control of solenoid valves in dangerous areas where explosion-proof protection Ex mb IIC T3/T4/T5 is required.

The coil is delivered with a 3m cable.



Specification		Double Frequency			
Reference		HZ10			
Certificate		LCIE 02 ATEX 6020 X - IECEx LCI 08.0027 X			
Coil Group		2.0 / 2.1			
Type of protection	Gas	II 2 G - Ex mb IIC T3/T4/T5			
	Dust	II 2 D - Ex tb IIIC T195°C / 130°C / 95°C			
Degree of protection		IP65 (with plug) according to IEC/EN 60529 Standards			
Ambient temperature		-40°C to +80°C / 65°C / 40°C The application is limited also by the temperature range of the valve.			
Insulation Class		H 180°C			
Duty cycle		100% continuous			
Electrical connection		Cable connection (3 x 1.5 mm ²) with cable gland M20 x 1.5, external earth screw connection.			
Elect. Power	DC	Pn (hot)	8 W		
		P (cold) 20°C	-		
	AC	Pn (holding)	8 W		
		Attraction cold	-		
Weight		299 g			
Voltages "Un"		VAC/Hz	Code	VDC	Code
-10% to +10% of the Un		24/60	B2	12	C1
		110/50-120/60	P3	24	C2
		220/50-240/60	Q3	120	C6

To Order a Coil choose Coil Ref + Voltage Code, example: HZ10 for 24 VDC = HZ10C2

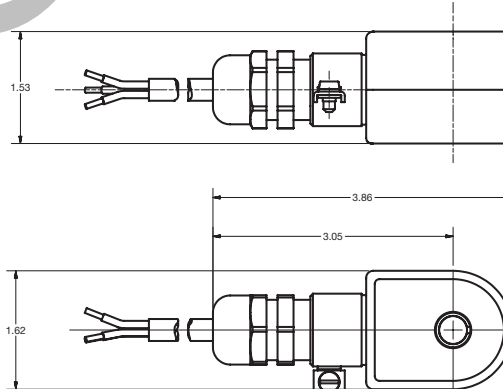

Dimensions in Inches.

HZ11 COIL DOUBLE FREQUENCY

This coil can be mounted with every Parker ATEX solenoid valves corresponding to the specified Coil Group.

See column "Coil Group" within valve pages.

Application: Control of solenoid valves in dangerous areas where explosion-proof protection Ex mb IIC T3/T4/T5 is required.

The coil is delivered with a 3m cable.



Specification		Double Frequency			
Reference		HZ11			
Certificate		LCIE 02 ATEX 6020 X - IECEx LCI 08.0027 X			
Coil Group		2.0 / 2.2			
Type of protection	Gas	II 2 G - Ex mb IIC T3/T4/T5			
	Dust	II 2 D - Ex tb IIIC T195°C / 130°C / 95°C			
Degree of protection		IP65 (with plug) according to IEC/EN 60529 Standards			
Ambient temperature		-40°C to + 65°C / 40°C The application is limited also by the temperature range of the valve..			
Insulation Class		H 180 °C			
Duty cycle		100% continuous			
Elect. Power	DC	Pn (hot)	14 W		
		P (cold) 20°C	-		
	AC	Pn (holding)	14 W		
		Attraction cold	-		
Weight		299 g			
Voltages "Un"		VAC/Hz	Code	VDC	Code
-10% to +10% of the Un		24/60	B2	12	C1
		110/50-120/60	P3	24	C2
		220/50-240/60	Q3	120	C6

To Order a Coil: Coil Ref + Voltage Code, example: HZ11 for 24 VDC = HZ11C2

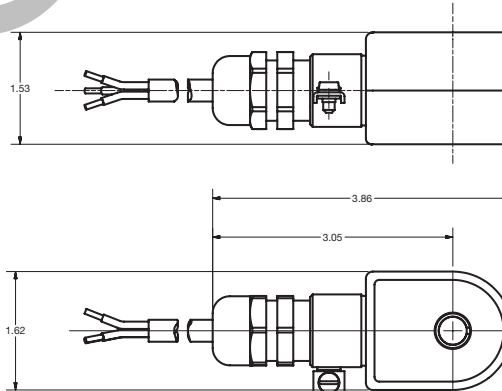

Dimensions in Inches.

COIL GROUPS

6.0

**FLAME PROOF ENCAPSULATED
ELECTRICAL PARTS
"db mb"**



495900 - LOW POWER ELECTRICAL PARTS 37 mm

This coil can be mounted with every Parker ATEX solenoid valves corresponding to the specified Coil Group.

See column "Coil Group" within valve pages.

Application: Control of solenoid valves in dangerous areas where explosion-proof protection Ex db mb IIC T4 to T6 is required.

Benefits: Rotatable 360° fibreglass-reinforced plastic housing (class H). Solenoid coil, rectifier (silicium diodes), fuses and varistor protection are completely encapsulated into the coil housing by epoxy resin for shock and corrosion protection.

The plastic housing is delivered with M20 x 1.5 cable gland certified for use "db" protection. Small size for ease of mounting in confined space.



ZONE 1/21

Reference		495900 (VAC)		495900 (VDC)	
Certificate		LCIE 03 ATEX 6451 X - IECEx LCI 06.0004 X			
Coil Group		6.0			
Type of protection	Gas	II 2 G - Ex db mb IIC T4 / T5 / T6		II 2 G - Ex db mb IIC T4 / T5 / T6	
	Dust	II 2 D Ex tb IIIC - 130°C / 95°C / 80°C		II 2 D Ex tb IIIC - T130°C / 95°C / 80°C	
Degree of protection		IP67 according to IEC/EN 60529 Standards			
Ambient temperature		-40°C to +80°C / 55°C / 40°C		-40°C to +80°C / 65°C / 55°C	
		The application is limited also by the temperature range of the valve.			
Class of insulation		H 180°C			
Electrical connection		Electric connection is done in the connection box on an easily accessible connector terminals. The introduction of the cable (Ø min 5 mm, Ømax. 11 mm, section max. 2.5 mm ²) in the connection box passes by the built in M20 x 1.5 cable gland			
Elect. Power	DC	Pn (hot)	-	2 W	
		P (cold) 20°C	-	2.5 W	
	AC	Pn (holding)	2.5 W	-	
		Attraction cold	3 W	-	
Voltages "Un"		VAC/Hz	Code	VDC	Code
-10% to +10% of Un for AC		24/50	A2	24	C2
- 10 % to + 10 % for Un DC.		48/50	A4	48	C4
		115/50	E5	110	C5
		230/50	F4		

To Order a Coil: Coil Ref + Voltage Code, example: 495900 for 24 VDC = 495900C2

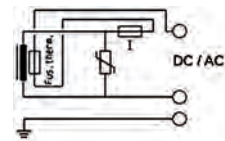
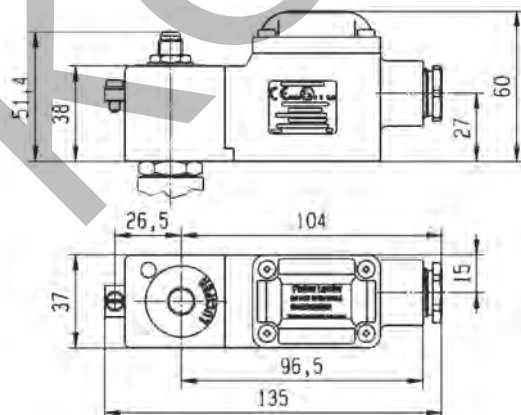



ZONE 1/21

495905 - ELECTRICAL PARTS 37 mm

These coils can be mounted with every Parker ATEX solenoid valves corresponding to the specified Coil Group.

See column "Coil Group" within valve pages.

Application: Control of solenoid valves in dangerous areas where explosion-proof protection Ex db mb IIC T4 is required.

Benefits: Rotatable 360° fibreglass-reinforced plastic housing (class H). Solenoid coil, rectifier (silicium diodes), fuses and varistor protection are completely encapsulated into the coil housing by epoxy resin for shock and corrosion protection.

The plastic housing is delivered with M20 x 1.5 cable gland certified for use "db" protection. Small size for ease of mounting in confined space.



Reference	495905		495905.05*		
Certificate	LCIE 03 ATEX 6451 X - IECEx LCI 06.0004 X				
Coil Group	2.0 / 2.1				
Type of protection	Gas	II 2 G - Ex db mb IIC T4			
	Dust	II 2 D - Ex tb IIIC - 130°C			
Degree of protection	IP67 according to IEC/EN 60529 Standards				
Ambient temperature	-40°C to +80°C				
Class of insulation	The application is limited also by the temperature range of the valve. H 180°C				
Electrical connection	Electric connection is done in the connection box on an easily accessible connector terminals. The introduction of the cable (Ø min 5 mm, Ømax. 11 mm, section max. 2.5 mm²) in the connection box passes by the built in M20 x 1.5 cable gland.				
Elect. Power	DC	Pn (hot)	8 W		
		P (cold) 20°C	9 W		
	AC	Pn (holding)	8 W		
		Attraction cold	9 W		
Voltages "Un"		VAC/Hz	Code	VDC	Code
-10% to +10% of Un for AC		24/50	A2	24	C2
-10% to +10% of Un DC		48/50	A4	48	C4
		115/50	E5	110	C5
		230/50	F4		

To Order a Coil choose Coil Ref + Voltage Code, example: 495905 for 24 VDC = 495905C2

* 495905.05 available only in C4

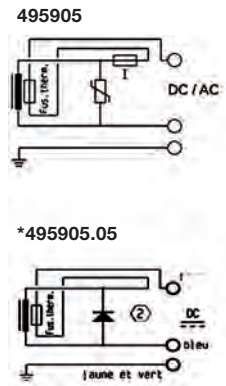
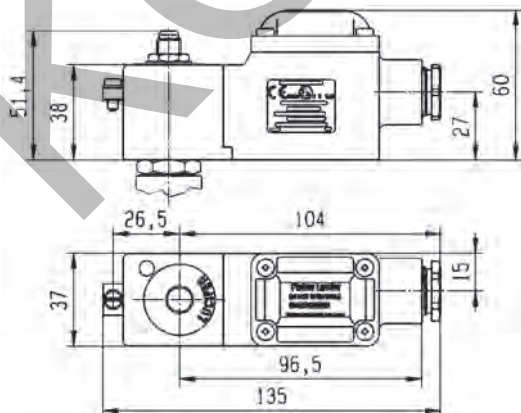

COIL GROUP

10.2/10.1

**FLAME PROOF ENCAPSULATED
ELECTRICAL PARTS
"db mb"**



496555 & 496560 - ELECTRICAL PARTS 37 mm

These coils can be mounted with every Parker ATEX solenoid valves corresponding to the specified Coil Group.

See column "Coil Group" within valve pages.

Application: Control of solenoid valves in dangerous areas where explosion-proof protection Ex db mb IIC T4 to T6 is required.

Benefits: Rotatable 360° fibreglass-reinforced plastic housing (class H). Solenoid coil, rectifier (silicium diodes), fuses and varistor protection are completely encapsulated into the coil housing by epoxy resin for shock and corrosion protection.

The plastic housing is delivered with M20 x 1.5 cable gland certified for use "db" protection. Small size for ease of mounting in confined space.



ZONE 1/2/1

Reference		496555				496560			
Certificate		LCIE 07 ATEX 6075 X - IECEx LCI 07.0014X							
Coil Group		10.2				10.1			
Type of protection	Gas	II 2 G - Ex db mb IIC T4 / T5 / T6				II 2 G - Ex db mb IIC T4			
	Dust	II 2 D - Ex tb IIIC - T130°C / 95°C / 80°C				II 2 D - Ex tb IIIC - T130°C			
Degree of protection		IP 67 according to IEC/EN 60529 Standards							
Ambiant temperature		-40°C to +65 / 50 / 35°C The application is limited also by the temperature range of the valve.				-40°C to +65°C			
Class of insulation		H 180°C							
Electrical connection		Electric connection is done in the connection box on an easily accessible connector terminals. The introduction of the cable (Ø min 5 mm, Ømax. 11 mm, section max. 2.5 mm ²) in the connection box passes by the built in M20 x 1.5 cable gland.							
Elect. Power	DC	Pn (hot)	-	6 W	-	-	8 W	-	-
		P (cold) 20°C	-	7.5 W	-	-	10.5 W	-	-
	AC	Pn (holding)	6 W	-	-	8 W	-	-	-
		Attraction cold	7.5 W	-	-	10.5 W	-	-	-
Voltages "Un"		VAC/Hz	Code	VDC	Code	VAC/Hz	Code	VDC	Code
-10% to +10% of the Un		230/50-60	P9	24	C2	230/50-60	P9	24	C2
		110/50-60	P2	48	C4	110/50-60	P2	48	C4
		24/50-60	P0	110	C5	24/50-60	P0	110	C5
		48/50-60	S4	-	-	48/50-60	S4	-	-

To Order a Coil choose Coil Ref + Voltage Code, example: 496555 for 24 VDC = 496555C2

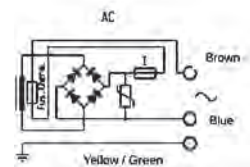
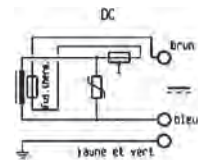
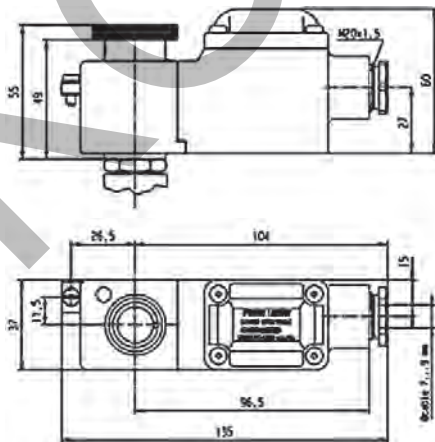

**FLAME PROOF ENCAPSULATED
ELECTRICAL PARTS
"db mb"**



ZONE 1/2/1

496700 & 496800 - ELECTRICAL PARTS 37 mm

These coils can be mounted with every Parker ATEX solenoid valves corresponding to the specified Coil Group.

See column "Coil Group" within valve pages.

Application: Control of solenoid valves in dangerous areas where explosion-proof protection Ex db mb IIC T4 to T6 is required.

Benefits: Rotatable 360° fibreglass-reinforced plastic housing (class H). Solenoid coil, rectifier (silicium diodes), fuses and varistor protection are completely encapsulated into the coil housing by epoxy resin for shock and corrosion protection.

The plastic housing is delivered with 1/2" NPT or M20 x 1.5 threaded hole for wide range of cable glands. Small size for ease of mounting in confined space.



Reference		496700 or 496700.02 (NPT)			496800 or 496800.02 (NPT)				
Certificate		LCIE 10 ATEX 3059 X - IECEX LCI 10.0023X							
Coil Group		10.2			10.1				
Type of protection	Gas	II 2 G - Ex db mb IIC T4 / T5 / T6			II 2 G - Ex db mb IIC T4				
	Dust	II 2 D - Ex tb IIIC - T130 / 95 / 80°C			II 2 D - Ex tb IIIC - T130°C				
Degree of protection		IP67 according to IEC/EN 60529 Standards							
Ambient temperature		-40°C to +35°C / +50°C / +65°C			-40°C to +65°C				
Class of insulation		H 180°C							
Electrical connection		Electric connection is done in the connection box passes through a 1/2 NPT or M20x1.5 thread in which a certified Ex dBIIC cable gland must be installed							
Elect. Power	DC	Pn (hot)	-	6 W	-	-	8 W		
		P (cold) 20°C	-	7.5 W	-	-	10.5 W		
	AC	Pn (holding)	6 W	-	-	8 W	-		
		Attraction cold	7.5 W	-	-	10.5 W	-		
Voltages "Un"		VAC/Hz	Code	VDC	Code	VAC/Hz	Code	VDC	Code
-10% to +10% of the Un		230/50-60	P9	24	C2	230/50-60	P9	24	C2
		110/50-60	P2	48	C4	110/50-60	P2	48	C4
		24/50-60	P0	110	C5	24/50-60	P0	110	C5
		48/50-60	S4			48/50-60	S4		

To Order a Coil choose Coil Ref + Voltage Code, example: 496700 for 24 VDC = 496700C2

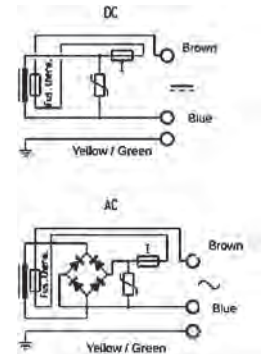
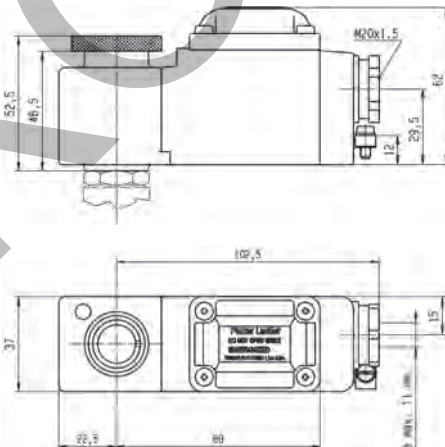

COIL GROUP

2.0/2.1

**FLAME PROOF ENCAPSULATED
ELECTRICAL PART
"db mb"**



493640 OR HZ09 - ELECTRICAL PARTS

This coil can be mounted with every Parker ATEX solenoid valves corresponding to the specified Coil Group.

See column "Coil Group" within valve pages.

Application: Control of solenoid valves in dangerous areas where explosion-proof protection Ex db mb IIC T4/T5 is required.

Benefits: Metal armature encapsulated in synthetic material provides high shock and corrosion protection.

Small size for ease of mounting in confined space.



ZONE 1/21

Reference	493640 493640.60*			
Certificate	LCIE 02 ATEX 6009 X			
Coil Group	2.0 / 2.1			
Type of protection	Gas	II 2 G Ex db mb IIC T4/T5		
	Dust	II 2 D - Ex tb III C - T130°C / T95°C		
Degree of protection	IP65 according to IEC/EN 60529 Standards			
Ambiant temperature	-40°C +75°C / +40°C The application is limited also by the temperature range of the valve.			
Class of insulation	F (155 °)			
Electrical connection	Special "Ex db" cable gland, galvanized steel, with EPDM sealing. (EPR) cable, outside diameter 7.3 ± 0.5 mm and 3000 mm long.			
Elect. Power	DC	Pn (hot)	8 W	
		P (cold) 20°C	9 W	
	AC	Pn (holding)	8 W	
		Attraction cold	32 VA (9 W)	
Weight	500 g			
Voltages "Un"	VAC/Hz	Code	VDC	Code
- 15% to +10% of the Un	110/50	A5	24	C2
	110-120/50-60	P3	48	C4
	220-240/50-60	Q3	120	C6

To Order a Coil choose Coil Ref + Voltage Code, example: 493640 for 24 VDC = 493640C2

* 493640.60 - 6 m cable length - Available only in C2

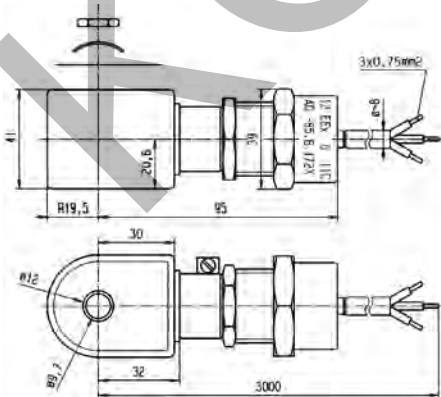

Fuses

This electrical part is equipped with a standard thermal cut-off fuse on all models and voltages

This electrical part must be connected in series with a safety fuse according to IEC 60127-3.

DC: 24V, 400 mA

AC: 110/50-120/60, 200 mA
220/50-240/60, 100 mA
230/50, 95 mA



ZONE 1/21

483371 & 494040 - ELECTRICAL PARTS 50 MM

This coil can be mounted with every Parker ATEX solenoid valves corresponding to the specified Coil Group.

See column "Coil Group" within valve pages.

Application: Control of solenoid valves in dangerous areas where explosion-proof protection Ex eb IIC T3 or T4 is required.

Benefits: Rotatable housing 360°, epoxy varnished steel with internal and external screw terminals for earth connection.

Small size for ease of mounting in confined space. Simplifies conversion of existing equipment to hazardous area requirements.



Reference		483371			494040				
Certificate		LCIE 02 ATEX 6011 X			LCIE 02 ATEX 6013 X				
Coil Group					2.0 / 2.1				
Type of protection	Gas	II 2 G - Ex eb IIC T4			II 2 G - Ex eb IIC T3 / T4				
	Dust	II 2 D - Ex tb IIIC - T130°C			II 2 D - Ex tb IIIC - T195°C / T130 °C				
Degree of protection		IP67 according to IEC/EN 60529 Standards							
Ambient temperature		-40°C to +65°C			-40°C to +90°C / to +65°C				
		The application is limited also by the temperature range of the valve.							
Class of insulation		F 155°C			H (180°)				
Electrical connection		By special cable gland or M20 x 1.5 "Ex eb" on screw terminals for wires up to 1.5 mm². Cables with outside diameter 6.5 mm to 13.5 mm can be simply sealed using the rubber gland with resilient sealing rings supplied.							
Elect. Power	DC	Pn (hot)	8 W			8 W			
		P (cold) 20°C	9 W			9 W			
	AC	Pn (holding)	8 W			8 W			
		Attraction cold	32 VA (9 W)			32 VA (9 W)			
Weight		320 g							
Voltages "Un"		VAC/Hz	Code	VDC	Code	VAC/Hz	Code	VDC	Code
-10% to +10% of the Un		24/50	A2	24	C2	220-230/50	3D	24	C2
		48/50	A4	48	C4				
		110-115/50	OA	110	C5				
		220-230/50	3D						

To Order a Coil choose Coil Ref + Voltage Code, example: 483371 for 24 VDC = 483371C2

Fuses:

Both electrical parts have to be connected in series with a safety fuse according to IEC 60127-3.

483371:

DC: 24 V, 400 mA - 48V, 250 mA - 110 V, 100 mA
AC 50HZ: 24 V, 630 mA - 48V, 315 mA - 110 V, 160 mA - 220/230 V, 80 mA

494040:

DC: 12 V, 400 mA - 24V, 200 mA - 48 V, 100 mA - 110V, 50 mA
AC 50HZ: 24 V, 250 mA - 48V, 125 mA - 110/115 V, 63 mA - 220/230 V, 32 mA

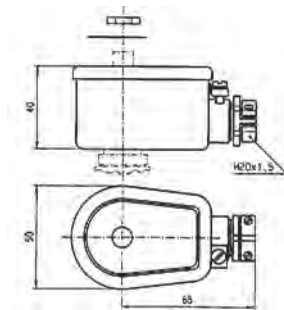

**INCREASED SAFETY
AND ENCAPSULATED
ELECTRICAL PARTS "eb mb"**



492310 - ELECTRICAL PARTS 50 mm

This coil can be mounted with every Parker ATEX solenoid valves corresponding to the specified Coil Group.

See column "Coil Group" within valve pages.

Application: Control of solenoid valves in dangerous areas where explosion-proof protection Ex eb mb II T4 to T5 is required.

Benefits: Rotatable 360° fibreglass-reinforced plastic housing. Solenoid coil, rectifier (silicium diodes), fuses and varistor protection are completely encapsulated into the coil housing by epoxy resin for shock and corrosion protection.

Small size for ease of mounting in confined space.



ZONE 1/21

Reference	492310			
Certificate	LCIE 02 ATEX 6023 X - IECEx LCI 06.0011 X			
Coil group	10.1			
Type of protection	Gas	II 2 G - Ex eb mb II T4 / T5		
	Dust	II 2 D - Ex tb IIIC - T130°C / T95°C		
Degree of protection	IP66 according to IEC/EN 60529 Standards			
Ambient temperature	-40°C to +75°C / to +40°C The operating temperature of the valve/coil can be limited by that of the valve			
Class of insulation	H 180°C			
Electrical connection	Connection box with terminals and cable entry via gland M20 x 1.5 - Possibility for additional earth via external screw.			
Elect. Power	DC	Pn (hot)	6 W	
		P (cold) 20°C	7.5 W	
	AC	Pn (holding)	6 W	
		Attraction cold	7.5 W	
Weight	500 g			
Voltages "Un"	VAC/Hz	Code	VDC	Code
-10% to +10% of the Un	24/50-60	P0	24	C2
	48/50-60	S4	48	C4
	230/50-60	P9	110	C5

To Order a Coil choose Coil Ref + Voltage Code, example: 492310 for 24 VDC = 492310C2

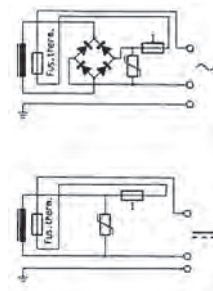
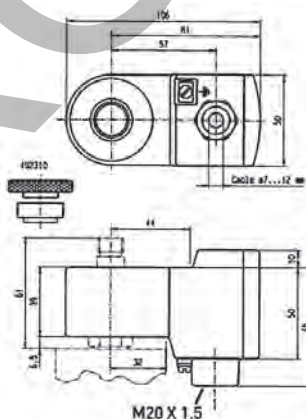

492210 - ELECTRICAL PARTS "BOOSTER" 50 mm

These coils can be mounted with every Parker ATEX solenoid valves corresponding to the specified Coil Group.

See column "Coil Group" within valve pages.

Application: Control of solenoid valves in dangerous areas where explosion-proof protection - Ex eb mb IIC T5/T6 is required.

Benefits: Rotatable 360° fibreglass-reinforced plastic housing. Solenoid coil, fuses and varistor protection are completely encapsulated into the coil housing by epoxy resin for shock and corrosion protection. Small size for ease of mounting in confined space. Simplifies conversion of existing equipment to hazardous area requirements.

Available only in 24 VDC (suffix code : C2)

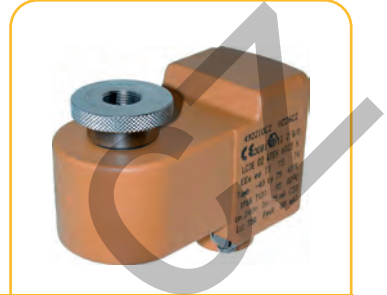

Reference	492210	
Certificate	LCIE 02 ATEX 6023 X - IECEx LCI 06.0011 X	
Coil group	9.0	
Type of protection	Gas	II 2 G - Ex eb mb IIC T5 / T6
	Dust	II 2 D - Ex tb IIIC - T95°C / T80°C
Degree of protection	IP66 according to IEC/EN 60529 Standards	
Ambient temperature	-40°C to +75°C / +40°C The operating temperature of the valve/coil can be limited by that of the valve	
Insulation Class	H 180°C	
Electrical connection	Connection box with terminals and cable entry via gland M20 x 1.5 Possibility for additional earth via external screw	
Power consumption DC	1 to 1.8 W according to length of cable	
Attraction current	I min = 60 mA (I nominal = 75 mA)	
Voltage DC	U nominal = 24 VDC (C2), Umin = 21.6 VDC	
Resistance	23 Ω + (R = 270 Ω)	
Inductance	0 mH	
Capacitance	0 μF	
Response time	2 - 4 s	
Weight	500 g	

To Order a Coil choose Coil Ref + Voltage Code, example: 492210 for 24 VDC = 492210C2

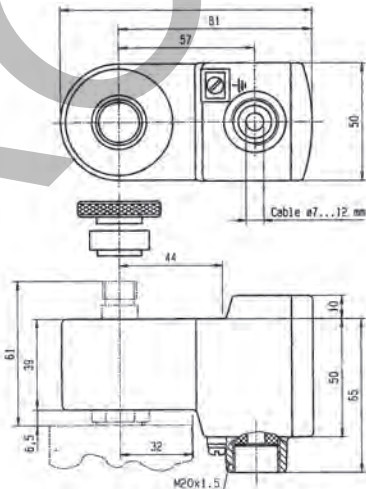

Indications:

Booster for Offshore valves

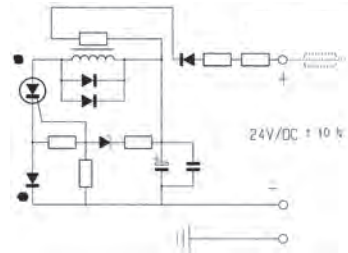

These electrical parts need an external fuse of I = 100 mA

COIL GROUP

2.0/2.1

**INCREASED SAFETY
AND ENCAPSULATED
ELECTRICAL PARTS "eb mb"**



492190 - ELECTRICAL PARTS 50 mm

This coil can be mounted with every Parker ATEX solenoid valves corresponding to the specified Coil Group.

See column "Coil Group" within valve pages.

Application: Control of solenoid valves in dangerous areas where explosion-proof protection Ex eb mb IIC T3 to T4 is required.

Benefits: Rotatable 360°, fiberglass -reinforced plastic housing. Solenoid coil, rectifier (silicium diodes), fuses and varistor protection are completely encapsulated into the coil housing by epoxy resin for shock and corrosion protection.

Small size for ease of mounting in confined space.



ZONE 1/21

Reference	492190			
Certificate	LCIE 02 ATEX 6023 X - IECEx LCI 06.0011 X			
Coil Group	2.0 / 2.1			
Type of protection	Gas	II 2 G - Ex eb mb IIC T3 / T4		
	Dust	II 2 D - Ex tb IIIC - 195°C / 130°C		
Degree of protection	IP66 according to IEC/EN 60529 Standards			
Ambient temperature	-40°C to +75°C / +40°C The operating temperature of the valve/coil can be limited by that of the valve			
Insulation Class	H 180°C			
Electrical connection	Connection box with terminals and cable entry via gland M20 x 1.5 Possibility for additional earth via external screw			
Electrical consumption	DC	Pn (hot)	9 W	
		P (cold) 20°C	11 W	
	AC	Pn (holding)	11 W	
		Attraction cold	13 W	
Weight	320 g			
Voltages "Un" -10% to +10% of the Un	VAC/Hz	Code	VDC	Code
	24/50-60	P0	24	C2
	110/50-60	P2	48	C4
	230/50-60	P9	110	C5

To Order a Coil choose Coil Ref + Voltage Code, example: 492190 for 24 VDC = 492190C2

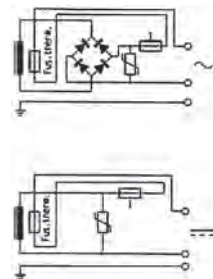
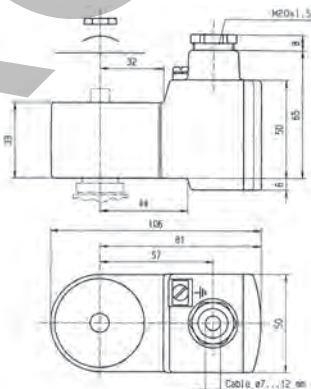

483580 - 483960 ELECTRICAL PARTS 32 mm "IS"

These coils can be mounted with every Parker ATEX solenoid valves corresponding to the specified Coil Group.

See column "Coil Group" within valve pages.

Application: Control of solenoid valves in dangerous areas where explosion-proof protection Ex ia IIC T6 is required.

Benefits: Fully encapsulated assembly comprising a coil, metal armature, three diodes circuit and DIN plug connection.

The encapsulation provides an effective compact housing offering full protection against dust, oil, water, etc.

Small size for ease of mounting in confined space. Available only in 28 VDC (suffix code : N7)



Reference (without plug) (with plug)	483580.01 483960.01
Certificate	LCIE 02 ATEX 6065 X - IECEx LCI 07.0025 X
Coil Group	7.0
Type of protection	Gas II 1 G - Ex ia IIC - T6 Dust II 1 D - Ex ta IIIC - T80°C
Degree of protection	IP65 with plug according to IEC/EN 60529 Standards
Ambiant temperature	- 40°C à + 55°C The operating temperature of the valve/coil can be limited by that of the valve.
Electrical connection	The coil is connected with a 2P + E plug according to EN 175301-803 type A Contact 1 is marked as the positive pole .
Maximum supply voltage	28 VDC (N7) - 110 mA The minimum operating voltage at maximum 60°C is 14 VDC.
Power	DC Minimum 500 mW
	Maximum 3 W
	Depending on applied voltage, IS barrier type and resistance of connected cable
Coil resistance at 20°C	340 Ω
Impedance	340 Ω
Apparent inductance	0 mH
Apparent capacitance	0 μF
Weight	160 g (with plug)

To Order a Coil choose Coil Ref + Voltage Code, example: 483580 for 28 VDC = 483580N7

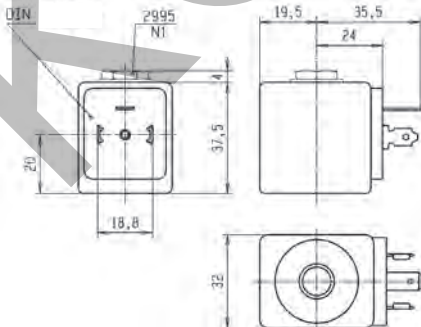

Important

The intrinsically safe supply circuit should have enough capacity in all environmental conditions to assure a minimum operating current of 35 mA through the coil.

For Valves with operator «96» and «97», a minimum current of 65 mA is required.

The minimal holding current is 20 mA.

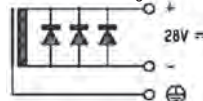

For the barrier compatibility see the corresponding table in in appendix section.

These coil must be used with suitable housing : Ref. 2995

COIL GROUP

8.0

**INTRINSICALLY SAFE
ELECTRICAL PARTS
"ia"**



**495910 - MINIWATT - 0.3 W
ELECTRICAL PARTS "IS" "BOOSTER" 37 mm**

These coils can be mounted with every Parker ATEX solenoid valves corresponding to the specified Coil Group.

See column "Coil Group" within valve pages.

Application: Control of solenoid valves in dangerous areas where explosion-proof protection Ex ia IIC T4 to T6 is required.

Benefits: Rotatable 360° fibreglass-reinforced plastic housing (class H). Solenoid coil, rectifier (silicium diodes), fuses and varistor protection are completely encapsulated into the coil housing by epoxy resin for shock and corrosion protection.

Small size for ease of mounting in confined space. Available only in 28 VDC (code: N7).



ZONE 0/20

Reference	495910	
Certificate	LCIE 03 ATEX 6464 X - IECEx LCI 07.0006 X	
Coil Group	8.0	
Type of protection	Gas	II 1 G - Ex ia IIC - T4 / T5 / T6
	Dust	II 1 D - Ex ta IIIC T80 / 95 / 130°C
Degree of protection	IP67 according to IEC/EN 60529 Standards	
Ambiant temperature	- 40°C to +80°C / 75°C / 65°C The application is limited also by the temperature range of the valve..	
Class of insulation	H 180°C	
Electrical connection	Electric connection is done in the connection box on an easily accessible connector terminals. The introduction of the cable (Ø min 7 mm, Ømax. 11 mm, section max. 2.5 mm²) in the connection box passes by the built in M20 x 1.5 cable gland	
Maximum supply voltage	28 VDC (N7) - 110 mA	
Power	DC Minimum	0.3 W (with 13 VDC)
	Maximum	1.2 W (with 24 VDC)
	Depending on applied voltage, IS barrier type and resistance of connected cable	
Line check	4 mA or 5 VDC max	
Coil resistance at 20°C	Charge ~ 550 Ω - Holding ~ 500 Ω	
Impedance	0 mH	
Apparent inductance	0 µF	
Apparent capacitance		
Response time	2 - 3 s	
Weight	500 g	

To Order a Coil choose Coil Ref + Voltage Code, example: 495910 for 28 VDC = 495910N7

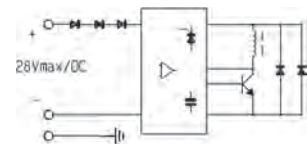
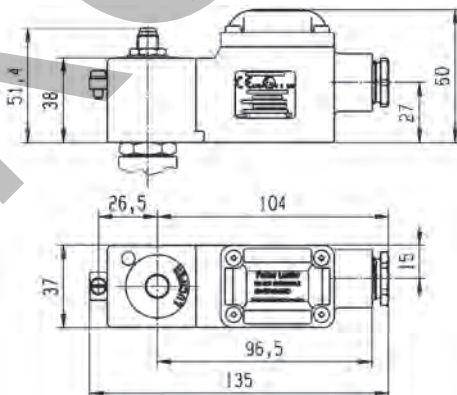

**496565 ELECTRICAL PARTS "BOOSTER"
"IS" 37 mm**

This coil can be mounted with every Parker ATEX solenoid valves corresponding to the specified Coil Group.

See column "Coil Group" within valve pages.

Application: Control of solenoid valves in dangerous areas where explosion-proof protection Ex ia IIC T4 to T6 is required.

Benefits: Rotatable 360° fibreglass-reinforced plastic housing (class H). Solenoid coil, rectifier (silicium diodes), fuses and varistor protection are completely encapsulated into the coil housing by epoxy resin for shock and corrosion protection.

The plastic housing is delivered with M20 x 1.5 cable gland. Small size for ease of mounting in confined space. Available only in 28 VDC (code: N7).



Reference	496565	
Certificate	LCIE 08 ATEX 6071 X - IECEx LCI 08.0030 X	
Coil group	9.0	
Type of protection	Gas	II 1 G - Ex ia IIC - T4 / T5 / T6
	Dust	II 1 D - Ex ta IIC - T80 / T95 / T130°C
Degree of protection	IP67 according to IEC/EN 60529 Standards	
Ambiant temperature	- 40°C to +80 / 75 / 65°C The application might also be limited by the temperature range of the valve.	
Electrical connection	Cable connection through a plastic cable gland M20 x 1.5 allowing use of cable diameter from 7 to 12 mm. Additional earth connection possible with external screw terminal.	
Class of insulation	H 180°C	
Minimum Courant of function	20 mA	
Minimum voltage of function at 60°C	28 VDC (N7)	
Safety parameters	28 V / 110 mA / 0.77 W	28 V / 280 mA / 1.96 W
Maximum acceptable values: Ui (V) / Ii (mA) / Pi (W)	27 V / 120 mA / 0.81 W	27 V / 320 mA / 2.16 W
	26 V / 135 mA / 0.88 W	26 V / 350 mA / 2.27 W
	25 V / 150 mA / 0.94 W	25 V / 390 mA / 2.43 W
	24 V / 170 mA / 1.02 W	24 V / 430 mA / 2.58 W
Line check	4 mA or 5 VDC max	
Apparent Impedance Typ.	Attraction ~ 600 Ω - Holding ~ 570 Ω	
Apparent Inductance	0 mH	
Apparent Capacitance	0 μF	
Response Time Typ.	2 - 4 s	
Weight	500 g	

To Order a Coil choose Coil.Ref + Voltage Code,
example: 496565 for 28 VDC = 496565N7

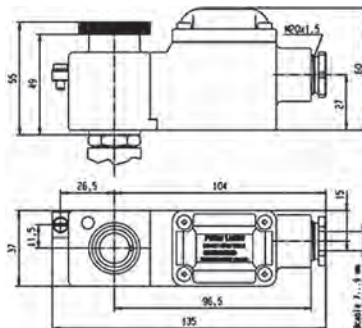

ZONE 0/20

COIL GROUP

9.0

**INTRINSICALLY SAFE
ELECTRICAL PARTS
"ia"**



**492965 ELECTRICAL PART
"BOOSTER" "IS" 50 mm**

This coil can be mounted with every Parker ATEX solenoid valves corresponding to the specified Coil Group.

See column "Coil Group" within valve pages.

Application: Control of solenoid valves in dangerous areas where explosion-proof protection Ex ia IIC - T6 is required.

Benefits: Rotatable 360° fibreglass-reinforced plastic housing. Solenoid coil, fuses and varistor protection are completely encapsulated into the coil housing by epoxy resin for shock and corrosion protection. Small size for ease of mounting in confined space. Simplifies conversion of existing equipment to hazardous area requirements.

Small size for ease of mounting in confined space. Available only in 28 VDC.

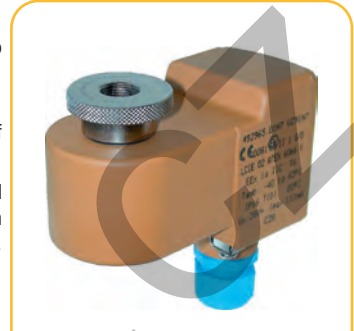

ZONE 0/20

Reference	492965.01 - (Stainless steel fixation) 492965.02 - (Plastic fixation)	
Certificate	LCIE 02 ATEX 6066 X - IECEx LCI 07.0007 X	
Coil Group	9.0	
Type of protection	Gas	II 1 G - Ex ia IIC - T6
	Dust	II 1 D - Ex ta IIIC - T80°C
Degree of protection	IP66 according to IEC/EN 60529 Standards	
Ambiant temperature	- 40°C to +65°C The application is limited also by the temperature range of the valve.	
Electrical connection	Cable connection through a plastic or stainless steel cable gland M20 x 1.5 allowing use of cable diameter from 10 to 12 mm. Additional earth connection possible with external screw terminal.	
Class of insulation	H 180°C	
Maximum supply voltage	28 VDC (N7) - 110 mA	
Power	DC Minimum	0.3 W (with 13 VDC)
	Maximum	2.3 W (with 24 VDC)
	Depending on applied voltage, IS barrier type and resistance of connected cable	
Line check	4 mA or 5 VDC max	
Coil resistance at 20°C	85 Ω	
Impedance	275 Ω (with 13 VDC) - 260 Ω (with 24 VDC)	
Apparent inductance	0 mH	
Apparent capacitance	0 μF	
Response time	2 - 4 s	
Weight	500 g	

To Order a Coil choose Coil Ref + Voltage Code, example: 492965.01 for 28 VDC = 492965.01N7

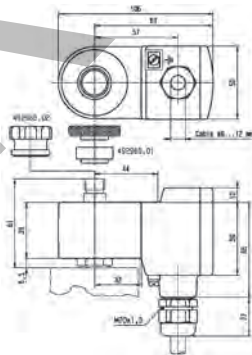

Important

The intrinsically safe supply circuit should have enough capacity in all environmental conditions to assure a minimum operating current of 29 mA through the coil.

The minimal holding current is 20 mA.

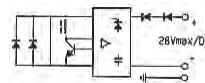

For the barrier compatibility see the corresponding table in appendix section.



ZONE 0/20

**488650.01 & 490885 "NEMA"
ELECTRICAL PARTS "IS" 50 mm**

This coil can be mounted with every Parker ATEX solenoid valves corresponding to the specified Coil Group.

See column "Coil Group" within valve pages.

Application: Control of solenoid valves in dangerous areas where explosion-proof protection Ex ia IIC - T6 is required.

Benefits: Rotatable 360° housing, polyamid with fibreglass housing and cover. Coil, electronic circuits and other elements required for intrinsic safety are completely encapsulated in the housing with epoxy material for shock and corrosion protection. Small size for ease of mounting in confined space.

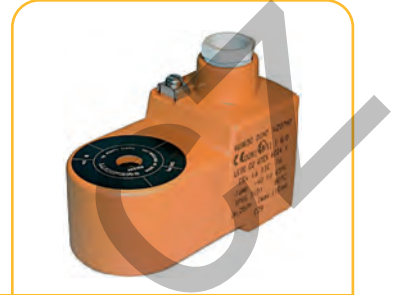

Reference	488650.01		490885	
Certificate	LCIE 02 ATEX 6024 X		LCIE / FM / CSA	
Coil Group			7.0	
Type of protection	Gas	II 1 G - Ex ia IIC - T6	Cl. I, Div.I, Gr. A, B, C, D, Cl. II, Div.I, Gr. E, F, G	
	Dust	II 1 D - Ex ta IIIC - T80°C		
Degree of protection	IP66 according to IEC/EN 60529 Standards		NEMA 4 - 4X	
Ambiant temperature	- 40°C to +65°C The operating temperature of the valve/coil can be limited by that of the valve.		60°C	
Electrical connection	Cable entry through a cable gland M20 x1.5. Screw terminals for leads 3 x 1.5 mm² max. Additional earth connection possible with external screw terminal			
Class of insulation	H 180°C			
Maximum supply voltage	28 VDC (N7) - 110 mA The minimum operating voltage at maximum 60°C is 11.5 VDC.		30 VDC(L8) - 100 mA	
Power	DC	Minimum	300 mW	
		Maximum	3 W	
Dependent on the applied voltage, type of barrier IS and the resistance of the connected cable				
Coil resistance at 20°C	295 Ω			
Impedance	345 Ω			
Apparent inductance	0 mH			
Apparent capacitance	0 µF			
Weight	500 g			

To Order a Coil choose Coil Ref + Voltage Code, example: 490885 for 30VDC = 490885L8

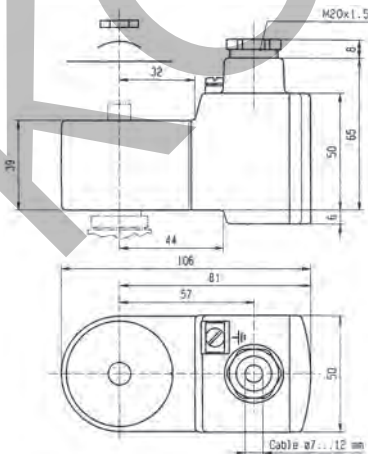

Important

The intrinsically safe supply circuit should have enough capacity in all environmental conditions to assure a minimum operating current of 29 mA through the coil.

The minimal holding current is 20 mA.

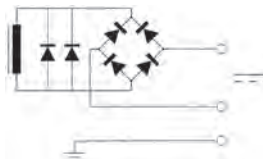

For the barrier compatibility see the corresponding table in appendix section.



482870.01 ELECTRICAL PARTS "IS" 50 mm

These coils can be mounted with every Parker ATEX solenoid valves corresponding to the specified Coil Group.

See column "Coil Group" within valve pages.

Application: Control of solenoid valves in dangerous areas where an explosion-proof protection Ex ia IIC - T6 is required.

Benefits: Rotatable 360° housing, polyamid with fibreglass housing and cover. Coil, electronic circuits and other elements required for intrinsic safety are completely encapsulated in the housing with epoxy material for shock and corrosion protection.

Small size for ease of mounting in confined space.



ZONE 0/20

Reference	482870.01	
Certificate	LCIE 02 ATEX 6024 X	
Coil Group	12.0	
Type of protection	Gas	II 1 G - Ex ia IIC - T6
	Dust	II 1 D - Ex ta IIIC - T80°C
Degree of protection	IP66 according to IEC/EN 60529 Standards	
Ambiant temperature	- 40°C to +65°C The application is limited also by the temperature range of the valve.	
Class of insulation	H 180°C	
Electrical connection	Cable connection through a stainless steel cable gland M20 x 1.5 allowing use of cable diameter from 10 to 12 mm. Additional earth connection possible with external screw terminal.	
Maximum supply voltage	28 VDC (N7) - 110 mA	
Power	DC	300 mW
	Minimum Maximum	3 W
	Depending on applied voltage, IS barrier type and resistance of connected cable	
Coil resistance at 20°C	295 Ω	
Impedance	345 Ω	
Apparent inductance	0 mH	
Apparent capacitance	0 μF	
Weight	500 g	

To Order a Coil choose Coil Ref + Voltage Code, example: 482870.01 for 30VDC =482870L8

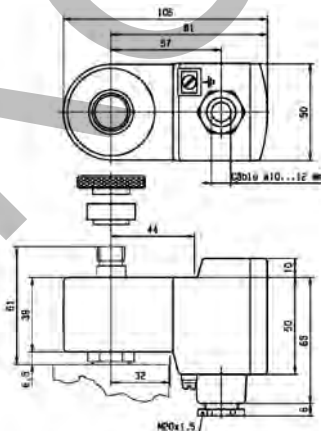

Important

The intrinsic safety supply circuit must have sufficient capacitance in all ambient conditions to guarantee a minimum operating current in excess of 29 mA across the coil.

The minimum current for holding in the energised position is 20 mA

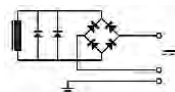

For the barrier compatibility see the corresponding table in appendix section.

KOVANZ.CZ

TABLE OF CONTENT

INTRODUCTION

Index for Explosion Proof Electrical Parts	414
List of Coil Groups	415

COILS

Coils for DIN plug connection	418
Coils with flying leads	432
Coils with screw terminal	434
Coils with ISO-DIN connector	441

EXPLOSION PROOF ELECTRICAL PARTS

Level of protection "nAc nCc"	445
Level of protection "db"	452
Level of protection "mb"	453
Level of protection "db mb"	457
Level of protection "eb"	462
Level of protection "eb mb"	463
Level of protection "ia"	466

HOUSINGS	474
-----------------------	-----

COIL ACCESSORIES	478
-------------------------------	-----

EXPLOSIVE ENVIRONMENTS	480
-------------------------------------	-----

COIL APPENDICES

Guidance chart for IS-Barriers	490
--------------------------------------	-----

COIL STANDARD HOUSING
WITH SCREW TERMINALS

Standard housing:

Reference:	4270
Material:	Epoxy varnished steel with cathaphoresis traitement
Degree of protection:	IP according to IEC/EN 60529 IP 10 with armoured conduit IP 44 with cable gland
Electrical connection:	Can be made with armoured conduit or cable gland M12x1.5. Parts No. 495740 (cable gland M12x1.5) and 484093 to be ordered separately. Grounding connection by screw M3 on the inside of housing base plate.
Weight:	120 g



Benefits:

This metal housing offers the ideal protection against shocks and corrosion - rotatable 360° - easy mounting in confined spaces - single-nut mounting - light weight - simplifies conversion of existing equipment to other requirements.

Application:

The majority of our valves can be fitted with this standard housing, and can be mounted with several compatible coils group.

Compatible coils:

- **481000 - Standard Coil**
8 W Class F (155°C)
- **483520 - Double-Frequency Coil**
9 W Class F (155°C)
- **481044 - Standard High-Power Coil**
14 W Class F (155°C)
- **485100 - Standard High-Temperature Coil**
8 W Class H (180°C)
- **486265 - High-Temperature and High-Power Coil**
14 W Class H (180°C)

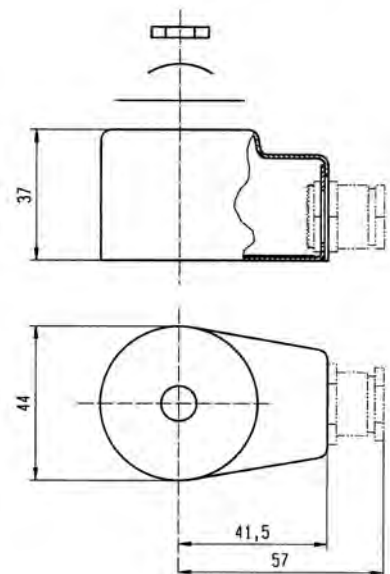

HOUSING

4269**HOUSING FOR BISTABLE
(IMPULSE) COILS****Housing for bistable coil:**

Reference:	4269
Material:	Epoxy vernished steel
Degree of protection:	IP according to IEC/EN 60529 IP 10 with armoured conduit IP 44 with cable gland
Electrical connection:	Can be made with armoured conduit or cable gland M12x1.5. Parts No. 484092 and 484093 to be ordered separately. Grounding connection by screw M3 on the inside of housing base plate.
Weight:	120 g

**Benefits:**

This metal housing offers the ideal protection against shocks and corrosion - rotatable 360° - easy mounting in confined spaces - single-nut mounting - light weight - simplifies conversion of existing equipment to other requirements.

Application:

This housing is specially designed for group 4.0 coils and can be mounted only with valves controlled by electrical impulses.

Compatible coils:

- **484990** - Impulse coil for AC
11 W Class F (155°C)
- **485400** - Impulse coil for DC
13 W Class F (155°C)

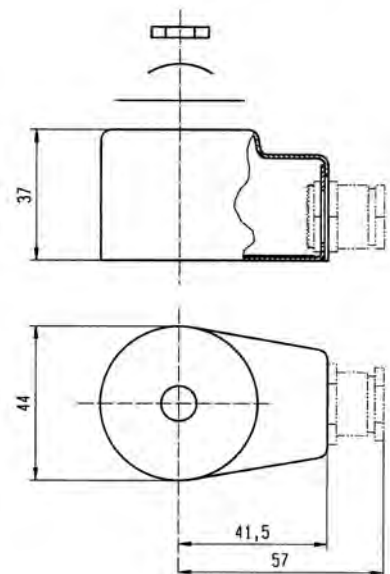

WATERPROOF AND DUSTPROOF HOUSING

Waterproof housing:

Reference:	4538
Material:	Epoxy varnished steel
Degree of protection:	IP according to IEC/EN 60529 IP 67 with cable gland
Electrical connection:	Cable connection by cable gland M20x1.5 according to DIN 46320. Cable with outer diameter 6.5 - 13.5 mm can be simply sealed using a rubber gland with resilient sealing rings. The enclosure is internally and externally fitted with grounding and earthing screw terminals.
Weight:	180 g



Benefits:

This enclosure is dust- and waterproof. It corresponds to the degree of "International Protection" IP 67 according to IEC / EN 60529. Corrosion resistant, the metal housing offers good protection for the coil against shocks and other outside influences - rotatable 360° - easy mounting in confined spaces - easy access to the screw terminals - single-nut mounting - light weight - simple conversion of existing electrical equipment to other requirements without interruption of fluid passage in the valve.

Application:

This housing can be equipped with several coils of our range, like the standard, double-frequency and magnetic latch coils.

Compatible coils:

- **481000 - Standard Coil**
8 W Class F (155°C)
- **483520 - Double-Frequency Coil**
9 W Class F (155°C)
- **484990 - Impulse Coil for AC**
11 W Class F (155°C)
- **485400 - Impulse Coil for DC**
13 W Class H (180°C)

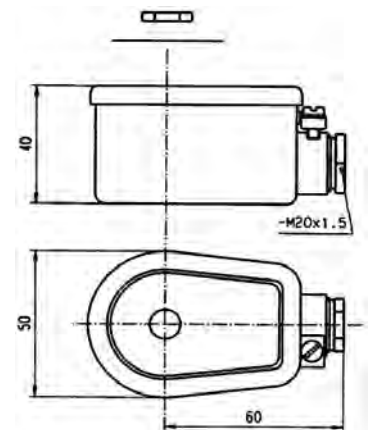

HOUSING

8520**WATERPROOF HOUSING
FOR HIGH-TEMPERATURE COILS****Waterproof housing:**

Reference:	8520
Material:	Epoxy varnished steel
Degree of protection:	IP according to IEC/EN 60529 IP 67 with cable gland
Electrical connection:	Cable connection by cable gland M20x1.5 according to European standards. Cable with outer diameter 6.5 - 13.5 mm can be simply sealed using a rubber gland with resilient sealing rings. The enclosure is internally and externally fitted with grounding and earthing screw terminals.
Weight:	180 g

**Benefits:**

This enclosure is dust- and waterproof. It corresponds to the degree of "International Protection" IP 67 according to IEC / EN 60529. Corrosion resistant, the metal housing offers good protection for the coil against shocks and other outside influences - rotatable 360° - easy mounting in confined spaces - easy access to the screw terminals - single-nut mounting - light weight - simple conversion of existing electrical equipment to other requirements without interruption of fluid passage in the valve.

Application:

The majority of our valves can be fitted with this housing and can be mounted with several compatible coils for high temperature (14 W, 8 W Class F or H).

Compatible coils:

- **481044 - Standard High-Power Coil**
14 W Class F (155°C)
- **486265 - High-Temperature and High-Power Coil**
14 W Class H (180°C)
- **485100 - Standard High-Temperature Coil**
8 W Class H (180°C)

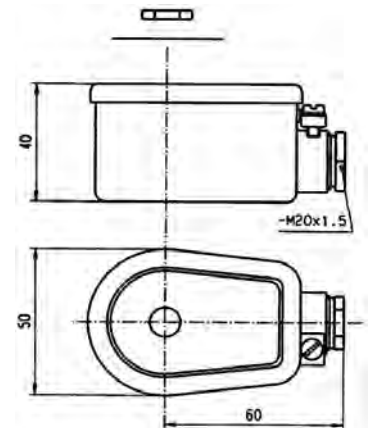

**22 mm
32 mm**

COIL ASSEMBLY KITS

COIL ASSEMBLY KIT FOR 22 mm COIL

The coil assembly kit corresponds to the "housing" of Parker valve numbering system (Valve - housing - coil/voltage).

It is composed of a nameplate with the details of the valve type, a washer and a nut to secure the 22 mm coil to the valve.

Caution: This coil assembly kits for 22 mm coils are not adapted for our "Namur High Flow Range".

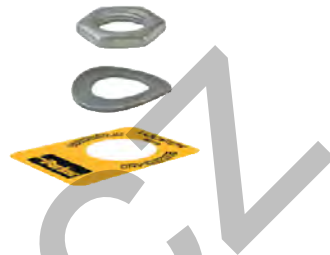

Reference	Specification	Application
8993	Standard - aluminium nameplate - passivated washer and nut - pressure indication in [bar]	Standard valves

COIL ASSEMBLY KIT FOR 32 mm COIL

The coil assembly kit corresponds to the "housing" of Parker valve numbering system (Valve - housing - coil/voltage).

It is composed of a nameplate giving details of the valve type, a round washer and a nut to ensure the fixing between 32 mm coil and the valve.



Reference	Specification	Application
2995	Standard - Aluminium nameplate - Passivated iron washer and nut - Pressure indication in [bar]	Standards valves

ACCESSORIES

DIN PLUG CONNECTOR ACCORDING TO EN 175301-803 - B

Part Number 48104340 (kit)

Electrical connection suitable for all 22 mm coils
(e.g. 488980, 481180)



DIN PLUG CONNECTOR ACCORDING TO EN 175301-803 - A

Part Number 48658640 (kit) or
Part Number 49264540 (kit) for high temperature Parker version

Electrical connection suitable for all 32 mm coils
(e.g. 481865, 492425)



PLASTIC NUT WITH METAL INSERT

For Oil & Gaz electrical parts
(e.g. 492965.01)



CABLE GLAND

No. 492398 - Pg 13.5 -Ex eb II
No. 493841 - M20x1.5 - Ex ia IIC

Electrical connection and mooring cable with 6 to 12 mm diameter, for electrical parts approved "eb mb" or "ia"
(e.g. 492190, 492965....)



CABLE GLAND

No. 493426 - 1/2"-14 NPT

Electrical connection and mooring cable with 6 to 12 mm diameter, for flameproof approved electrical parts
(e.g. 493640)





EXPLOSIVE ENVIRONMENTS

INTRODUCTION

The current European Directive concerning equipment to be installed in potentially explosive atmospheres is **2014/34/EU**. It came into force on April 19th, **2016**. With respect to the previous version, it implies the switching from EC to EU Declarations of Conformity and Type Examination Certificates; moreover, it better defines the manufacturer's, importer's and distributor's responsibilities.

Electrical and mechanical equipment for use in potentially explosive atmospheres is certified by a notified body in accordance to the relevant European technical standards concerning each protection mode (m , d , e , i , n , t , h), EN 60079-0 etc. After certification project completion, and EU Type Examination Certificate is released, entitling it to carry the distinctive marking.

EUROPEAN MEMBER COUNTRIES





DEFINITIONS

EXPLOSIVE ENVIRONMENTS

Mixture with air, under atmospheric conditions, of flammable substances in the form of gases, vapours, mists or dusts in which, after combustion has occurred, combustion spreads to the entire unburned mixture.

HAZARDOUS AREAS

A hazardous area is an area in which an explosive gas environment is present, or may be expected to be present, in quantities such as to require special precautions for construction, installation and use of electrical apparatus.

INGREDIENTS FOR AN EXPLOSION

- When combustible materials are mixed with air, an explosive mixture is produced. Danger of explosion therefore exists wherever these hazardous materials are handled: such a condition is to be found on the biggest chemical plant as well as at the smallest filling station.
- Nowadays with the use of electronic and electrical instrumentation in process control, the risk of combustion by electrical energy has increased sharply.
- To protect personnel and expensive equipment special precautions should be taken to prevent combustion of those dangerous substances. Conditions likely to ignite explosive mixtures are as follows:

Three conditions are enough to create an explosion.

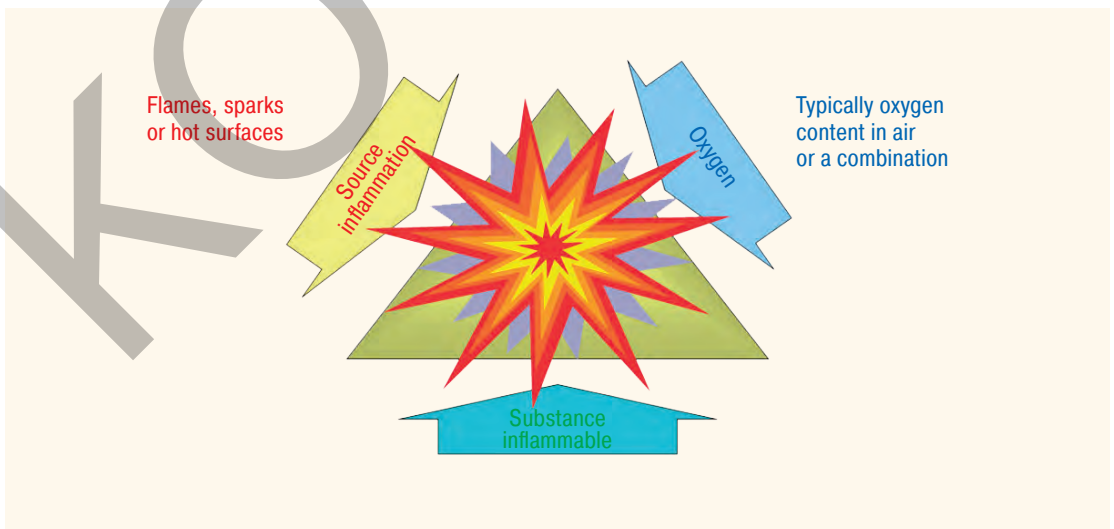



EXPLOSIVE ENVIRONMENTS

DEFINITIONS

ZONES

The hazardous areas are classified in zones based on the frequency of the occurrence and the duration of an explosive gas environment as follows:

Zone 0 (20)	Zone 1 (21)	Zone 2 (22)
An area in which an explosive gas (dust) atmosphere is present CONTINUOUSLY or is present for LONG PERIODS (~1000 h/y).	An area in which an explosive gas (dust) atmosphere is present LIKELY TO OCCUR in normal operation (~10 to 999 h/y).	An area in which an explosive gas (dust) atmosphere is not LIKELY TO OCCUR and if it does occur it will exist for short period only (~1 to 10 h/y).
Mode of protection: ia - ta ...	Mode of protection: db - mb - eb - tb...	Mode of protection: ec - tc...

HAZARDOUS LOCATION CLASSIFICATION

Explosive Environment	Continuous Presence	Intermittent Presence (normal operation conditions)	Occasional Presence (abnormal operation)
IEC	Zone 0 (gas) Zone 20 (dust)	Zone 1 (gas) Zone 21 (dust)	Zone 2 (gas) Zone 22 (dust)
Europe	Zone 0 (gas) Zone 20 (dust)	Zone 1 (gas) Zone 21 (dust)	Zone 2 (gas) Zone 22 (dust)
Canada (CEC) ¹ USA (NEC) ²	Cl. I Div. 1 (gas) Cl. II Div. 1 (dust) Cl. III Div. 1 (fibres)	Cl. I Div. 1 (gas) Cl. II Div. 1 (dust) Cl. III Div. 1 (fibres)	Cl. I Div. 2 (gas) Cl. II Div. 2 (dust) Cl. III Div. 2 (fibres)

¹ (CEC): Code Canadien d'Electricité / ² (NEC): National Electrical Code

Example:

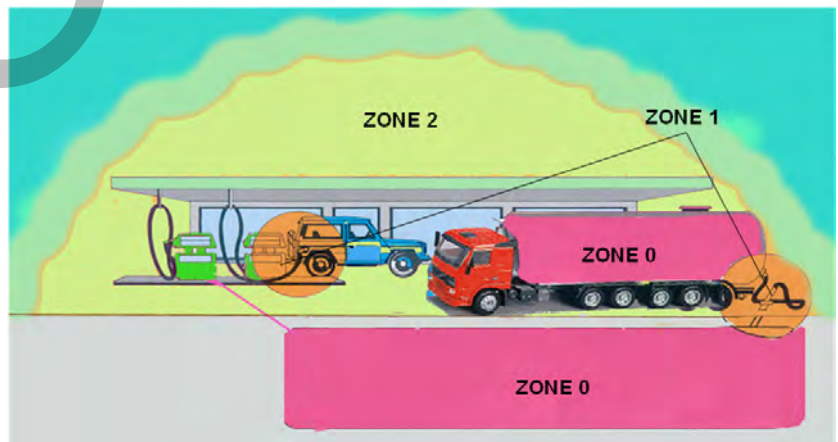



DEFINITIONS

HAZARDOUS LOCATION CLASSIFICATION

Category	Fault protection	Atmosphere	Zone	Example of protections
----------	------------------	------------	------	------------------------

EC Type examination by Notified Body annex III

1 Very high level	2 types of protection or 2 independant faults	G (Gas)	0	"ia", "ta"...
		D (Dust)	20	

EC Type examination by Notified Body annex III

2 High level	One type of protection Habitual frequent malfunction	G (Gas)	1	One type of protection "db", "mb", "tb"...
		D (Dust)	21	

Internal production inspection EC declaration of conformity

3 Normal	Required level of protection	G (Gas)	2	"ec", "tc"...
		D (Dust)	22	

Hazardous Location Classification

Group	Gas Reference
I	Methane
IIA	Propane
IIB	Ethylene
IIC	Hydrogen / Acetylene

Hazardous Location Classification

Group	Dust Reference
-	-
IIA	Fibres
IIB	Non-conductive dust
IIC	Conductive dust

Surface Temperature Classes

Class	Temperature	Max. Temperature
T1	450°C	
T2	300°C	
T3	200°C	
T4	135°C	
T5	100°C	
T6	85°C	



Gas & Ignition Temperature		
560°C	Hydrogen	T1
537°C	Methane	T1
425°C	Ethylene	T2
305°C	Acetylene	T2
210°C	Kerozene	T3
160°C	Ethylether	T4
95°C	Carbon disulphide	T6



EXPLOSIVE ENVIRONMENTS

PROTECTION MODES IN PARKER FCSE PRODUCTS

Concept	Code		Zones	
	Gas	Dust	Gas	Dust
Flameproof enclosure	db	tb	1/2	21/22
Encapsulation	mb	tb	0/1/2	20/21/22
Increased Safety	eb	tb	1/2	21/22
Intrinsic Safety	ia	ta	0/1/2	20/21/22
Concept Cat.3 apparatus	nc	tc	2	22
Mechanical Part	h	h	0/1/2	20/21/22

In red, protection modes used by Parker FCSE.



STANDARDS AND PROTECTION MODES

ELECTRICAL EQUIPMENT FOR EXPLOSIVE GAS ATMOSPHERE EQUIPMENT GROUP II

EPL	Standards EN / IEC	Protection	Title
Ga	60079-0	-	General requirements
	60079-11	ia	Intrinsic safety
	-	-	-
Gb	60079-1	db	Flameproof enclosures
	60079-7	eb	Increased safety
	60079-18	mb	Encapsulation
Gc	60079-7	ec	Increased safety
	60079-15	nc	Non sparking (C) or protected sparking (A)
	-	-	-

EPL = Equipment Protection Level

In red, protection modes used by Parker FCSE.



EXPLOSIVE ENVIRONMENTS

STANDARDS AND PROTECTION MODES



ELECTRICAL EQUIPMENT FOR EXPLOSIVE DUST ATMOSPHERE - EQUIPMENT GROUP III

EPL	Standards EN / IEC	Protection	Title
	60079-0	-	General requirements
Da	60079-31	ta	Protection by enclosure
	60079-11	ia	Intrinsic safety
	-	-	-
Db	60079-31	tb	Protection by enclosure
	60079-18	mb	Protection by encapsulation
	-	-	-
Dc	60079-31	tc	Protection by enclosure
	-	-	-
	-	-	-

EPL = Equipment Protection Level

In red, protection modes used by Parker FCSE.

NON ELECTRICAL EQUIPMENT FOR USE IN POTENTIALLY EXPLOSIVE ATMOSPHERE

Standards	Protection	Title
ISO / EN ISO 80079-36	h	Basic method and requirement
ISO / EN ISO 80079-37	c, b, k	Constructional safety, control of ignition sources, liquid immersion

ZONES AND EQUIPEMENT PROTECTION LEVEL (EPL)

Gas			Dust		
Zone	EPL		Zone	EPL	
0	Ga		20	Da	
1	Ga and Gb		21	Da and Db	
2	Ga, Gb and Gc		22	Da, Db and Dc	

CATEGORIES AND EQUIPEMENT PROTECTION LEVEL (EPL)

Categories	Gas	Dust	Safety
1	Ga	Da	Very high
2	Gb	Db	High
3	Gc	Dc	Normal



EXAMPLES OF MARKING

ELECTRICAL APPARATUS FOR EXPLOSIVE GAS ATMOSPHERES EQUIPMENT GROUP II

Protection Mode

Ex db IIC T5 Gb

Equipment Groups (Gas)	Temperature Class	Ignition Temperature of Gas or Vapour	Maximum admissible surface temperature for permanently hot surfaces	Zone	Equipment Protection Level (EPL)
IIA Aceton, ethane, benzene, petrol, butane, propane, methane	T1	> 450°C	440°C	0	Ga
	T2	> 300°C	290°C	1	Gb and Ga
IIB Ethylene, town gas	T3	> 200°C	195°C	2	Gc, Gb and Ga
IIC Hydrogen, acetylene	T4	> 135°C	130°C		
	T5	> 100°C	95°C		
	T6	> 85°C	80°C		

ELECTRICAL EQUIPMENT FOR USE IN AREAS WITH COMBUSTIBLE DUST - EQUIPMENT GROUP III

Protection Mode

Surface Temperature Max.

Ex tb IIIC T95°C Db

Equipment Groups (Dust)	
IIA	Fibres
IIB	Non-conductive dust
IIC	Conductive dust

Zone	Equipment Protection Level (EPL)
20	Da
21	Db and Da
22	Dc, Db and Da



EXPLOSIVE ENVIRONMENTS

WHAT ABOUT THE DIRECTIVE ?

(2014/34/EU - 19.04.16)

ATEX 100 A DIRECTIVE - NEW APPROACH

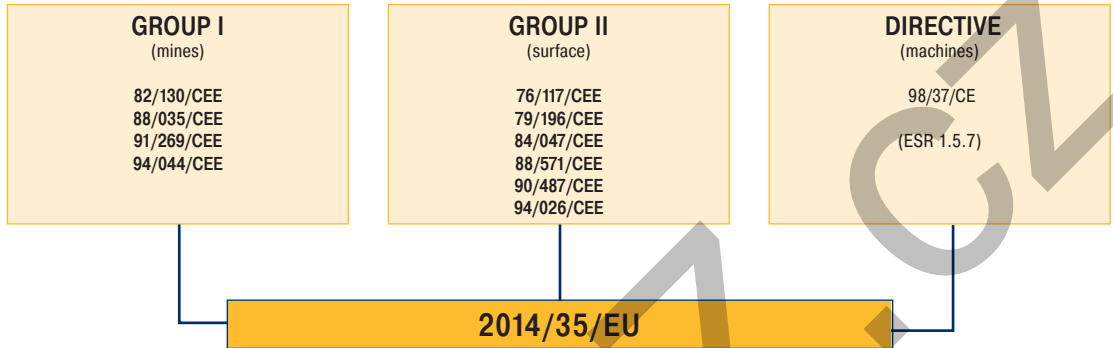

THE FRAMEWORK OF THE DIRECTIVE

The main principles of the new directive can be summarized as follows:

- It applies to **electric** and **non-electric** equipment.
- It defines **essential health and safety requirements**.
- It takes into consideration **all potential hazards** equipment may cause, in particular at design and production level.
- **The one directive** applies to both **mines** susceptible to fire damp and **surface industries**.
- It stresses the importance of equipment being **used in accordance with its intended purpose**.
- It recognises The European Standards Committee **CEN** and the European Committee for Electrotechnical Standardisation **CENELEC** as competent bodies to fix the required harmonised standards.
- It provides for the **contribution of labour and management**.
- It defines **procedures for assessing conformity** to essential requirements, on the basis of modules which qualify equipment to carry the **CE** mark of conformity.

APPLICATIONS

The directive applies to the industrial field and concerns the following equipment:

- **Equipment** (machines, apparatus, etc.)
- **Protective systems** (discharge devices, explosion suppression devices, etc.)
- **Components** (parts with no autonomous function, terminals, etc.)
- **Safety devices, controlling devices and regulating devices** intended for use outside potentially explosive environments but required for safety with respect to explosions (relays, barriers, pressure switches, thermostats, etc.)



WHAT ABOUT THE DIRECTIVE ? (2014/34/EU - 19.04.16)

EXCLUDED FROM THE SCOPE OF THE NEW DIRECTIVE

The following equipment falls outside the scope of the new directive:

- Medical devices intended for use in a medical environment.
- Equipment and protective systems relating only to the risk of explosion of unstable chemical substances (explosives, etc.)
- Equipment intended for use in domestic and non-commercial environments.
- Personal protective equipment covered by directive 89/686/EC.
- Seagoing vessels and mobile offshore units.
- Means of transport, except for vehicles intended for use in a potentially explosive environment.

POTENTIAL IGNITION SOURCES AND OTHER HAZARDS TO BE CONTROLLED

The following all represent potential hazards:

- Various sources of ignition, such as sparks, flames, electric arcs, high surface temperature, acoustic energy, optical radiation or electromagnetic waves.
- Static electricity.
- Pressure compensation operations.
- Disturbance from external sources, such as changing environmental conditions, extraneous voltage, humidity, vibration or contamination.

Provision is also made for specific requirements governing devices used to provide additional equipment safety.

These requirements necessitate detailed analysis to assess the operational reliability of such devices and their interaction with other components connected with the equipment.



GUIDANCE CHART FOR IS-BARRIERS

Manufacturer	Reference	Ex	IS Standard Electrical Parts						IS Booster Electrical Parts				
			Ex ia IIC T6 488650.01/02	Ex ia IIC T6 490885	Ex ia IIC T6 483580.01/03 483960.01/03	Ex ia 490880 (493997)	Ex ia IIB T6 482160,01	Ex ia IIC T6 482870,01	Ex ia	Ex ia IIC T6 492965.01/02	Ex ia IIC T6 496565	Ex ia IIC T6 495910	
			LCIE/AUS	LCIE/FM/CSA (490895)	LCIE/AUS	LCIE/FM/CSA	LCIE	LCIE	LCIE/FM/CSA	LCIE	LCIE	LCIE	
A puissance 3	NAEV 22-140	ia	●	-	●	-	●	●	-	●	●	●	
	NAEV 26-100	ia	●	-	●	-	●	●	-	●	●	●	
ABB	V171132-54	ib	●	-	●	-	●	●	-	●	●	●	
	V171132-55	ib	●	-	-	-	●	ib	-	●	●	●	
	V171132-61	ia	●	-	-	-	●	●	-	●	●	●	
	DO 890	ib	●	-	●	-	●	●	-	●	●	●	
	S900-DO4-EX	ib	●	-	●	-	●	●	-	●	●	●	
BRADLEY	FEX-EX 24V	ia	●	●	●	●	●	●	-	●	●	●	
COOPER	LB 2101	ia	●	●	●	●	●	●	●	●	●	●	
	LB 2105	ia	●	●	●	●	●	●	●	●	●	●	
	LB 2112	ia	●	●	●	●	●	●	●	●	●	●	
ELCON	1881 / 1882	ia	●	●	●	●	●	●	●	●	●	●	
	471 / 472	ia	●	●	●	●	●	●	●	●	●	●	
	2871/2872	ia	●	●	●	●	●	●	●	●	●	●	
	2874/2875/2876	ia	●	●	●	●	●	●	●	●	●	●	
GEORGIN	AVB 122	ia	●	-	●	-	●	●	-	●	●	●	
	AVB 125	ia	●	-	●	-	●	●	-	●	●	●	
	AVB 128	ia	●	-	●	-	●	●	-	●	●	●	
Hima	F3328A	ib	●	-	●	-	●	●	-	●	●	●	
	F3335	ib	●	-	-	-	●	●	-	●	●	●	
	H4007	ib	●	-	-	-	●	●	-	●	●	●	
MTL	728P, 7128P, 7728P	ia	-	-	-	-	●	●	-	●	●	●	
	728, 7028, 7128, 7728	ia	●	●	●	●	●	●	●	●	●	●	
	3021, 4021, 4021S	ia	●	-	●	-	●	●	-	●	●	●	
	3022	ia	-	-	-	-	●	-	-	-	-	-	
	4023	ia	-	-	-	-	●	-	-	-	-	-	
	4024	ia	●	-	●	-	●	●	-	●	●	●	
	4025	ia	●	●	●	●	●	●	●	●	●	●	
	5021, 5023, 5024	ia	●	-	●	-	●	●	-	●	●	●	
	5025	ia	●	-	●	-	●	●	●	●	●	●	
	4521 / 4523 / 4524	ia	●	-	-	-	●	●	●	●	●	●	
	5521 / 5523 / 5524	ia	●	-	-	-	●	●	●	●	●	●	
	Pepperl & Fuchs	Z 728	ia	●	●	●	●	●	●	●	●	●	●
		Z 779	ia	●	●	●	●	●	●	●	●	●	●
EGA-041-3		ia	-	●	●	●	●	●	●	●	●	●	
KFD2-SD-EX1.36		ia	-	-	-	-	-	●	-	-	-	-	
KFD2-SL-EX1.36		ia	-	-	-	-	-	-	-	-	-	-	
KFD2-SD-EX1.48		ia	-	●	-	●	-	●	●	●	●	●	
KFD2-SL-EX1.48		ia	-	●	-	●	-	●	●	●	●	●	
KFD2-SL-EX1.48.90A		ia	-	-	-	-	-	-	-	●	●	●	
KFD2-SL-EX1.48.90A		ia	-	-	-	-	-	-	-	●	●	●	
KFD2-SL2-EX1.LK		ia	-	●	-	●	-	●	●	●	●	●	
KFD2-SL2-EX2		ia	-	●	-	●	-	●	●	●	●	●	
KSD2-BO-EX		ia	-	●	●	●	●	●	●	●	●	●	
RSD-BO-EX4		ib	-	●	-	●	-	●	●	●	●	●	
RSD-VO-EX8		ib	-	-	-	-	-	-	-	●	●	●	



GUIDANCE CHART FOR IS-BARRIERS

Manufacturer	Reference	Ex	IS Standard Electrical Parts						IS Booster Electrical Parts			
			Ex ia IIC T6 488650.01/02 LCIE/AUS	Ex ia IIC T6 490885 (490895) LCIE/FM/CSA	Ex ia IIC T6 483580.01/03 483960.01/03 LCIE/AUS	Ex ia 490880 (493997) LCIE/FM/CSA	Ex ia IIB T6 482160,01 LCIE	Ex ia IIC T6 482870,01 LCIE	Ex ia LCIE/FM/CSA	Ex ia IIC T6 492965.01/02 LCIE	Ex ia IIC T6 496565 LCIE	Ex ia IIC T6 495910 LCIE
SIEMENS	5RD00-0AB0	ib	-	-	-	-	-	-	-	●	-	-
	7RD00-0AB0	ia	-	-	-	-	-	-	-	●	-	●
	7RD01-0AB0	ia	-	-	-	-	-	-	-	●	●	●
	7RD10-0AB0	ia	-	-	-	-	-	-	-	●	●	●
	7RD11-0AB0	ia	-	-	-	-	-	-	-	●	●	●
	7RD20-0AB0	ia	-	-	-	-	-	-	-	●	●	●
	7RD21-0AB0	ia	-	-	-	-	-	-	-	●	●	●
STAHL	9001/01-252-100-14	ia	●	●	27 V	27 V	●	●	●	●	●	●
	9001/01-280-100-10	ia	●	●	24 V	24 V	●	●	●	●	●	●
	9001/01-280-110-10	ia	●	-	24 V	-	●	●	-	●	●	●
	9002/13-280-100-04	ia	24 V	24 V	27 V	27 V	24 V	24 V	24 V	17 V	17 V	17 V
	9311/52-11-10	ia	-	●	●	25 V	25 V	●	●	15 V	15 V	15 V
	9111/63-11-00	ia	-	●	●	25 V	25 V	●	●	15 V	15 V	15 V
	9351/10-15-10	ia	-	●	●	-	-	●	●	●	●	●
	9351/10-16-10	ia	-	●	●	●	●	●	●	●	●	●
	9351/10-17-10	ia	-	-	-	-	-	●	●	-	-	-
	9381/10-187-050-10	ib	-	●	●	●	●	●	●	●	●	●
	9381/10-246-055-10	ib	-	●	●	●	●	●	●	●	●	●
	9381/10-246-070-10	ib	-	●	●	●	●	●	●	●	●	●
	9465/12-04-11	ib	-	●	●	-	-	●	●	●	●	●
	9475/12-04-21	ia/ib	-	●	-	●	-	●	●	●	●	●
	9475/12-04-31	ia/ib	-	-	-	-	-	-	-	●	●	●
	9475/12-08-41	ia/ib	-	-	-	-	-	-	-	-	-	-
	9475/12-08-51	ib	-	-	-	-	-	-	-	●	●	●
	9475/12-08-61	ia/ib	-	-	-	-	-	-	-	-	●	●
	Turck	MK72-S01-EX	ib	-	-	-	-	●	●	-	●	●
MK72-S02-EEX		ib	-	-	-	-	●	●	-	●	●	●
MK72-S04-EEX		ib	●	-	●	-	●	●	-	●	●	●
MK72-S05-EEX		ib	●	-	-	-	●	●	-	●	●	●
MK72-S06-EEX		ib	●	-	●	-	●	●	-	●	●	●
MK72-S07-EEX		ib	●	-	-	-	●	●	-	●	●	●
MK72-S09-EEX		ia	-	-	-	-	-	-	-	-	-	-
MK72-S12-EEX		ia	●	-	●	-	●	●	-	●	●	●
MC72 - 41		ia	●	-	●	-	●	●	-	●	●	●
MC72 - 43		ia	●	-	●	-	●	●	-	●	●	●
BARTEC	07-7331-2301/1000	ia	●	-	-	-	●	●	-	●	-	-
	07-7331-2301/1100	ia	●	-	●	-	●	●	-	●	-	-

If barrier reference not listed, consult factory for compatibility (FCCE.FCSE.Technical@support.parker.com)

TECHNICAL INFORMATION ABOUT SOLENOID VALVES

General Information

Solenoid valves are electro-mechanical devices used for interrupting or diverting the flow of fluids by opening or closing one or more orifices.

The solenoid valve is a combination of three basic components:

1. An electromagnet consisting of a solenoid (windings) and a magnetic yoke.
2. A pilot with a moveable plunger (which, in some cases directly opens and closes the valve).
3. A valve body with an orifice opened or closed by plunger or diaphragm to enable or prevent flow of the medium.

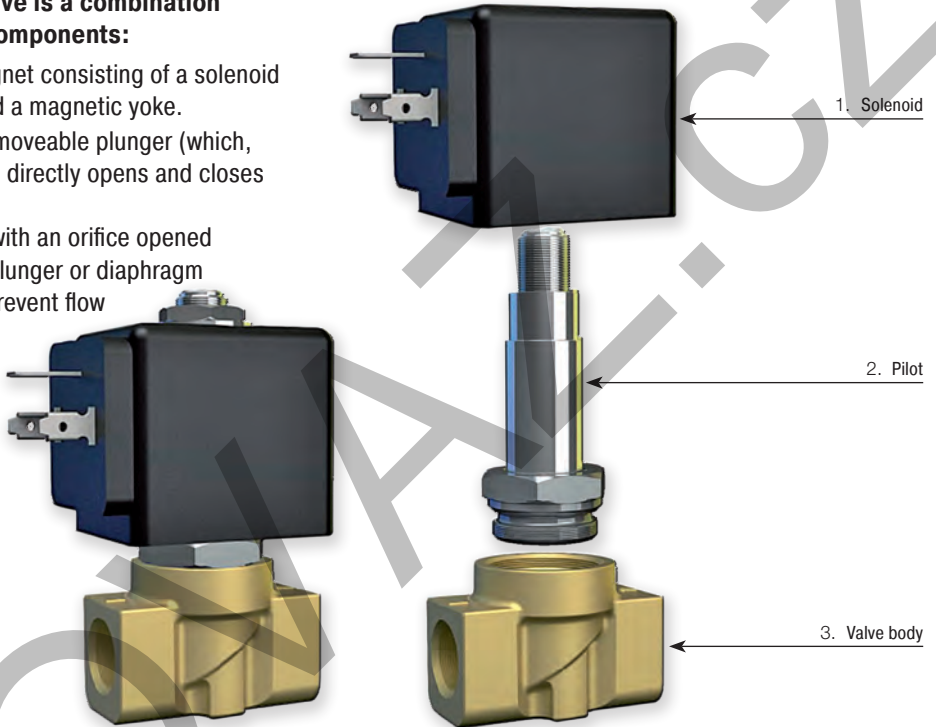

Operating principles

The term solenoid refers to operator and coil, also known as pilot or magnetic actuator.

The coil consists of copper wire wound on a support reel. When electric current is applied into the coil, magnetic flow lines are generated which are stronger in the coil center.

This magnetic flow raises the moveable plunger in the coil until it brings it into contact with the pole piece. The valve body has an orifice through which the fluid flows when the valve is open.

The moveable plunger has an integral seat which when the solenoid coil is energised, moves off the valve (direct operated) orifice or diaphragm (pilot operated) orifice opening the valve.

When the coil is de-energised, a return spring brings the plunger back to the original closing position, thus cutting off the flow of the fluid.

BASIC COMPONENTS OF A SOLENOID VALVE

- Valve body:** Main part of the solenoid valve including ports, seat and orifices.
- Solenoid tube assembly:** Cylinder, in stainless steel, hermetically sealed and closed at one extremity. It is the guide channel of the moveable plunger which is moved magnetically. The solenoid coil is fitted on the external side of the enclosing tube.
- Moveable plunger:** Made by ferritic stainless steel, it is attracted by the solenoid magnetic field and slides inside the tube.
- Plunger spring (or return spring):** Used to hold the moveable plunger in position and to return it when de-energized.
- Seat seal:** Part of the moveable plunger, it is used to close a valves main orifice or pilot orifice.
- Electromagnet (or solenoid coil):** Electrical part consisting of a copper windings (solenoid) along, with a magnetic yoke (armature), when electric current flows through, it generates a magnetic field attracting the moveable plunger.
- Housing:** Part that contains and protects the coil.
- Yoke:** Metallic case surrounding the coil and concentrating electro-magnetic force on the moveable plunger.

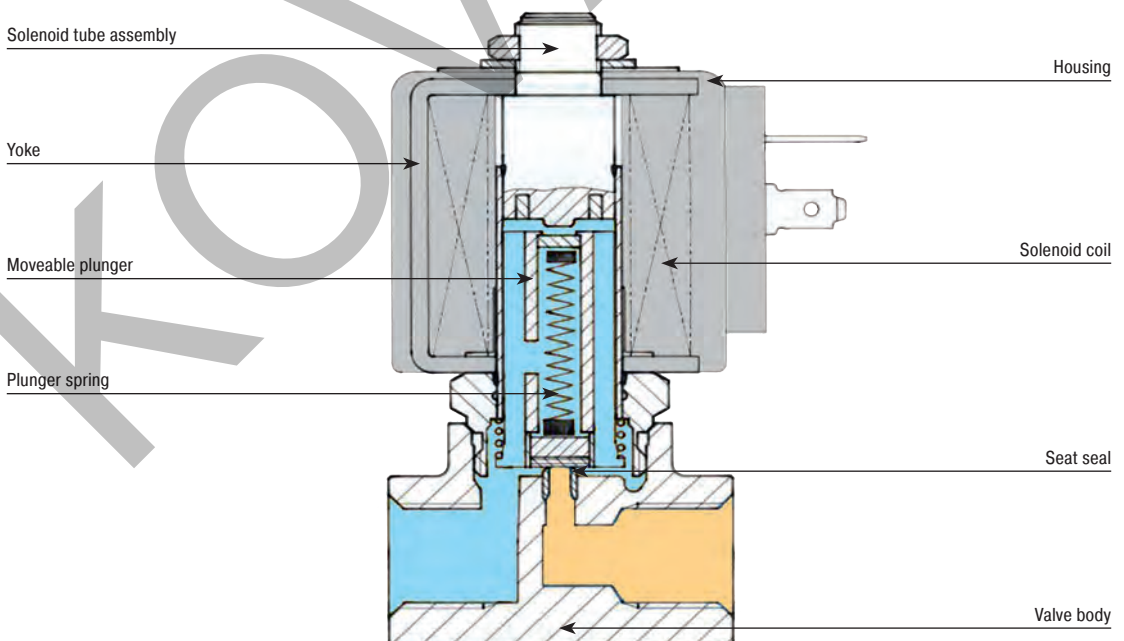

TECHNICAL VOCABULARY USED IN TABLES

Actuation	Body	Function	Port Size	Orifice (mm)	Flow Factor Kv(l/min)	MOPD (bar)	Max Fluid Temp. (°C)
-----------	------	----------	-----------	--------------	-----------------------	------------	----------------------

NORMALLY CLOSED

Port size	Orifice Ø	Flow factors			Operating Pressure Differential			Fluid Temp.		Seat Seal	Parker Valves			Power		Coil Group	Dwg. No.
		Kv l/min	KV m³/h	Qn l/min	Min bar	Max(MOPD) AC bar	DC bar	Min °C	Max °C		Valve Ref.	Housing Ref.	Coil Ref.	AC W	DC W		

The basic technical features of each solenoid valve are indicated in the tables, the terminology used is shown and explained below. Please notice that in certain sections you will have the choice between two product ranges: Parker valves, within blue tables and the Parker valves, within orange tables.

- Actuation:** The mechanical method used to control the flow.
- Body:** Main part of the solenoid valve with the ports, seats and orifice needed.
- Function:** The way the valve operates when de-energised.
- Port Size:** Fitting dimensions are defined as threaded in inches (G), in BSP or Sub-base, when a flat interface for ports is adopted.
- Orifice (mm):** Main orifice diameter in millimetres (nominal diameter).
- Flow Factors:** Define the quantity of water which flows through the solenoid valve with a pressure drop of 1 bar during one minute. Expressed in l/min and m³/h.
- Max Fluid Temperature:** Maximum fluid temperature the valve can withstand.
- Max Ambient Temperature:** Maximum ambient temperature the valve can withstand typical value for pressure vessel is 50°C.
- Minimum Operating Pressure Differential:** The lowest differential pressure required for operation (bar).
- Maximum Operating Pressure Differential (MOPD):** The highest working differential pressure with 90% of the rated voltage (-10% Vn) applied to the solenoid coil (for AC) and 95% of the rated voltage (-5% Vn)(for DC).

KOLVAZ.CZ

TECHNICAL INFORMATION

Solenoid valves are highly engineered products that can be used in many diverse applications.

In addition to operational functionality, media compatibility and suitability for the operating environment when selecting the best product for a given application.

This section provides a brief overview of the components, actuation and function modes of solenoid valves available from Parker Hannifin - FCSE.

Different Technologies:

Solenoid valves are electrically operated devices used to control flow. The most common types of solenoid valve are:



**Direct Operated
Valves**



Magnalift Valves

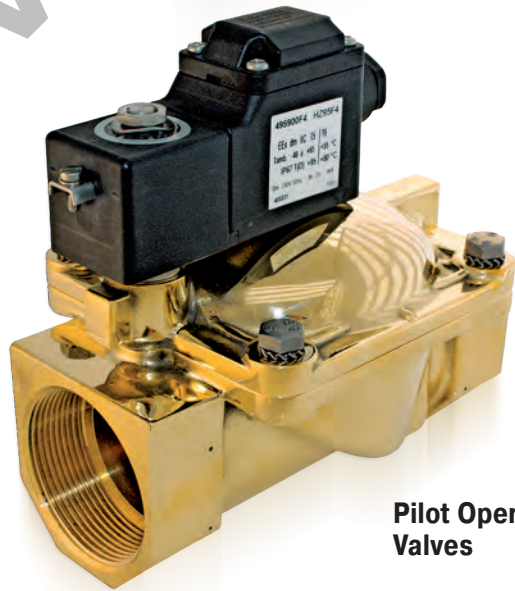

**Pilot Operated
Valves**

DIRECT OPERATED VALVE

Magnetic force is used directly to open or close the plunger which controls the passage of the fluid. Performances are limited by the coil, the pressure, and the valve orifice size. For direct operated valves, the minimum working pressure is 0 bar and the maximum pressure relies on the combination (valve/coil) chosen.

Direct Operated Valve

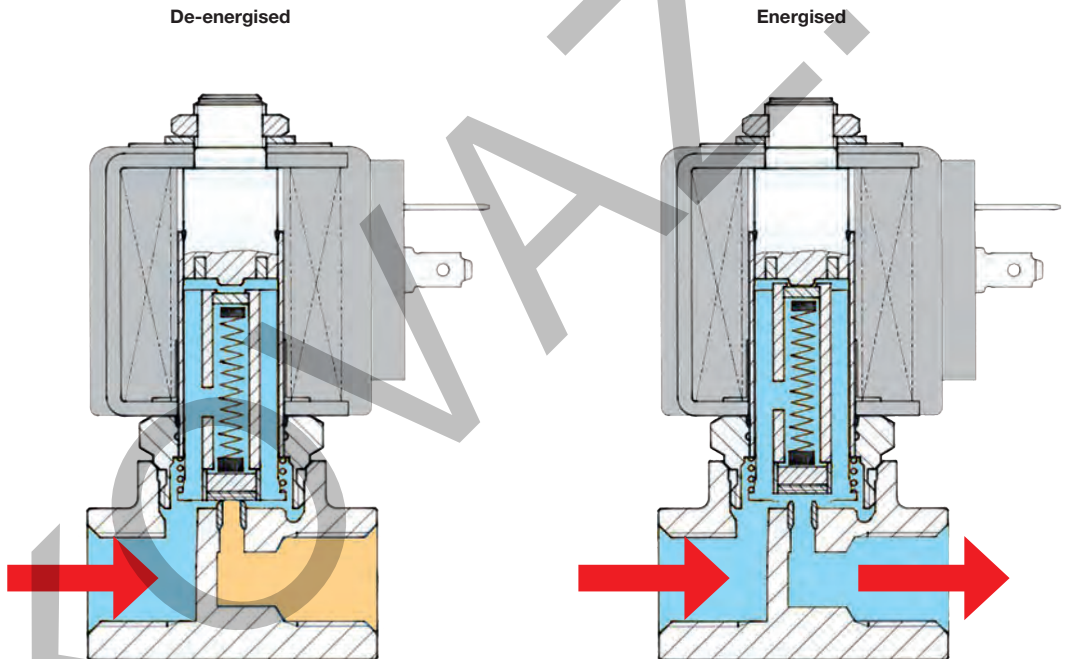

Example:
• 121 Series

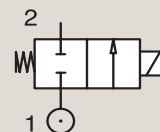

PILOT OPERATED VALVE

To control a higher flow, it is necessary to use pilot operated valves. The supply pressure enters the direct operated "pilot stage" which directs the flow to a "pilot chamber" which, in turn, applies the pilot pressure over a large area (generally a diaphragm or piston). Therefore, a large force is generated to move the main sealing elements against higher pressure or over a large orifice.

One condition of operation is to have a minimum pressure available to shift the valve (indicated in the catalogue). In most applications, this presents no particular problems (refer to magnalift valve section).

The pressure rating of the valve starts between 0.1 to 0.5 bar (depending on the valve).

(NB. Pilot Operated Valves are also called Servo Operated Valves).

Pilot Operated Valve

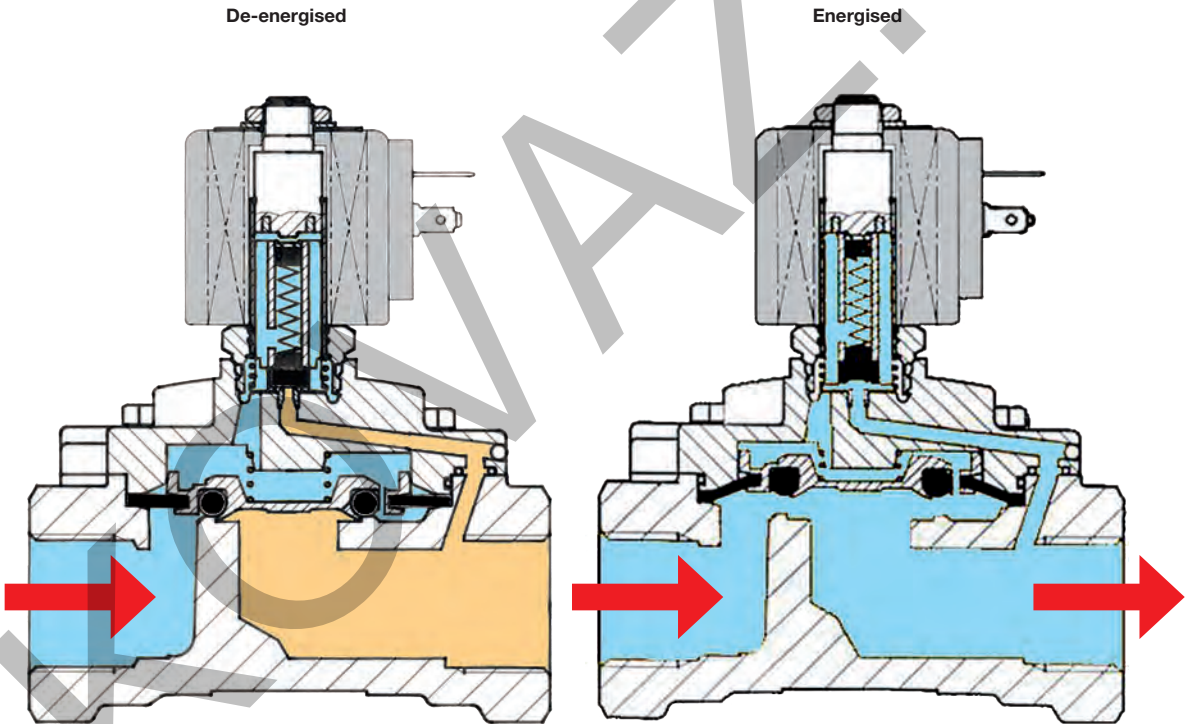

Example:

- 321 Series
- 7321B Series

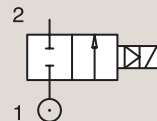

MAGNALIFT VALVE

The magnalift valves combine the features of the direct operated and pilot operated valves. A mechanical link between the plunger and diaphragm retainer allows the valve to operate as a direct operated valve at low pressures and as a pilot operated valve at higher pressures. Magnalift valves are specially designed for applications where 0 pressure is needed to operate the valve, as well as bigger flow than a direct operated valve.

Magnalift Operated Valve

De-energised

Energised

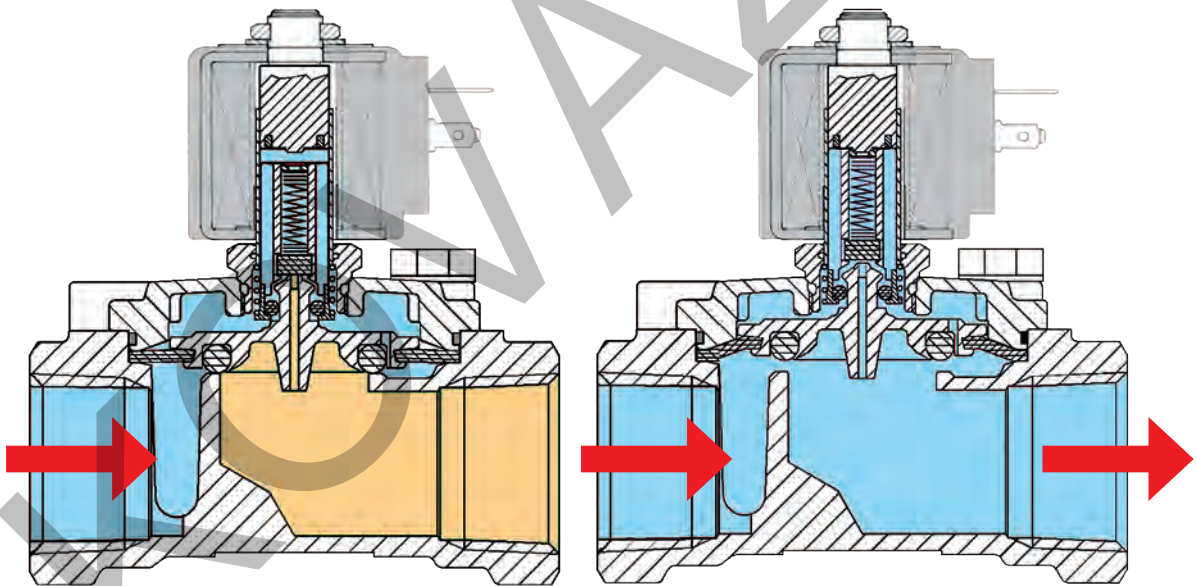

Example:
• 221 Series

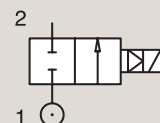

NORMALLY CLOSED VALVE

Most of our valves are available in normally closed and normally open configuration when not energized. In certain applications, you may require a normally open valve (open function in case of current failure). The differentiating factor of design of this technology, is based upon the design of the seat seal, which is reversed in comparison to a normally closed valve.

Normally Closed Valve

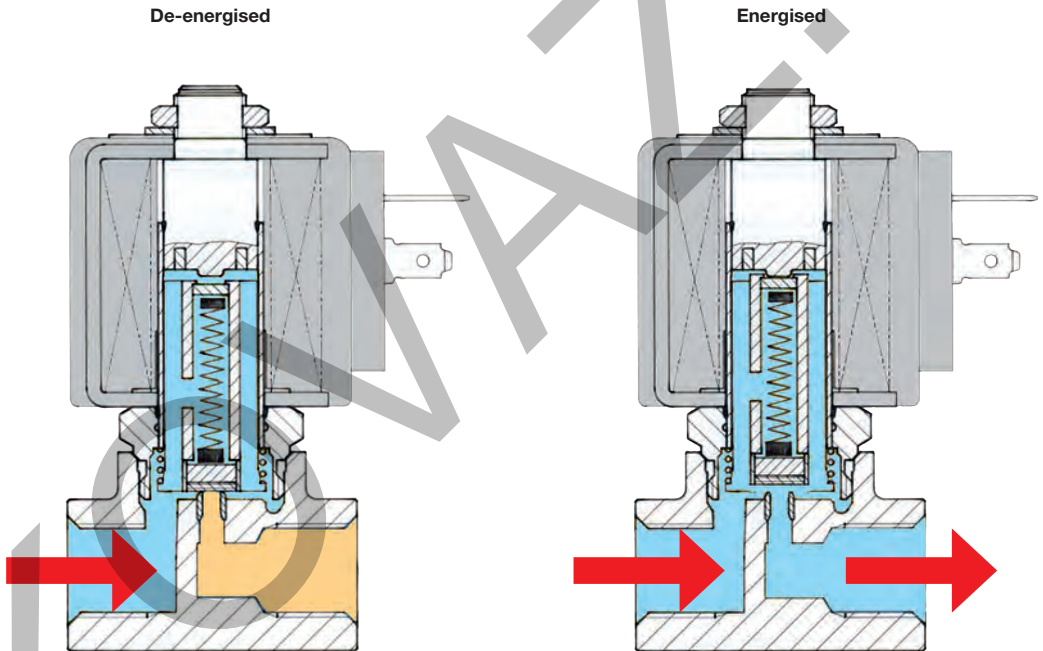

Example:
• 121 Series

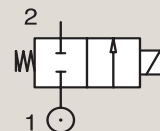

NORMALLY OPEN VALVE

Normally Open Valve

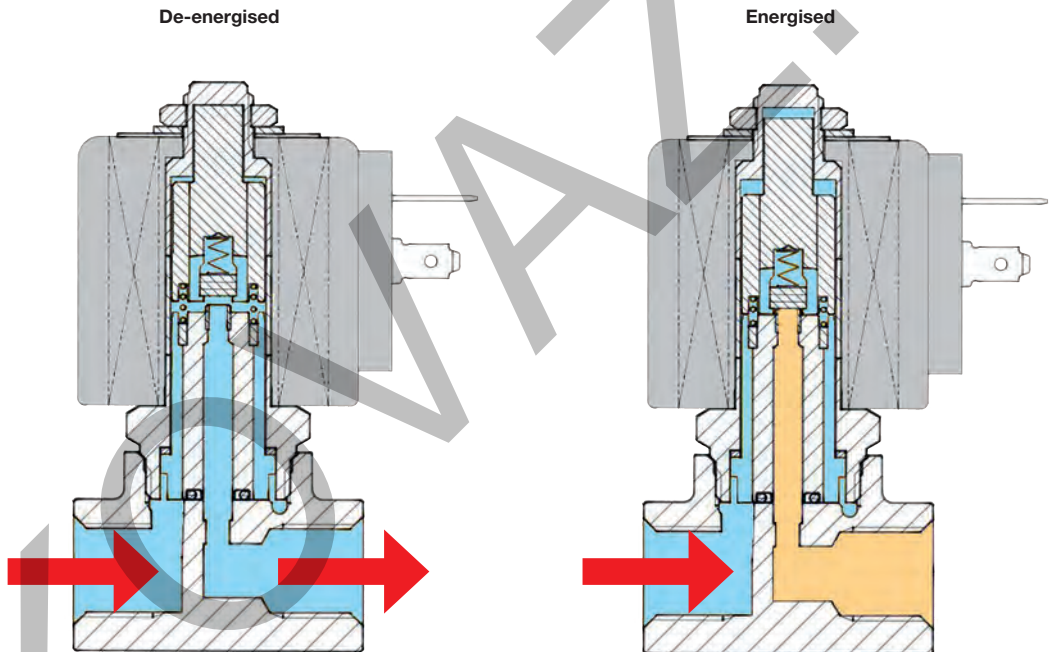

Example:
• 122 Series

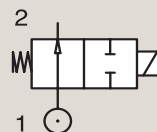

FLOW AND PRESSURE RANGES

Area of operation:

Each valve principle, as described in the previous pages, has a defined area of operation related to its pressure and flow capabilities. The following graph shows which type of valve is suitable for a certain situation.

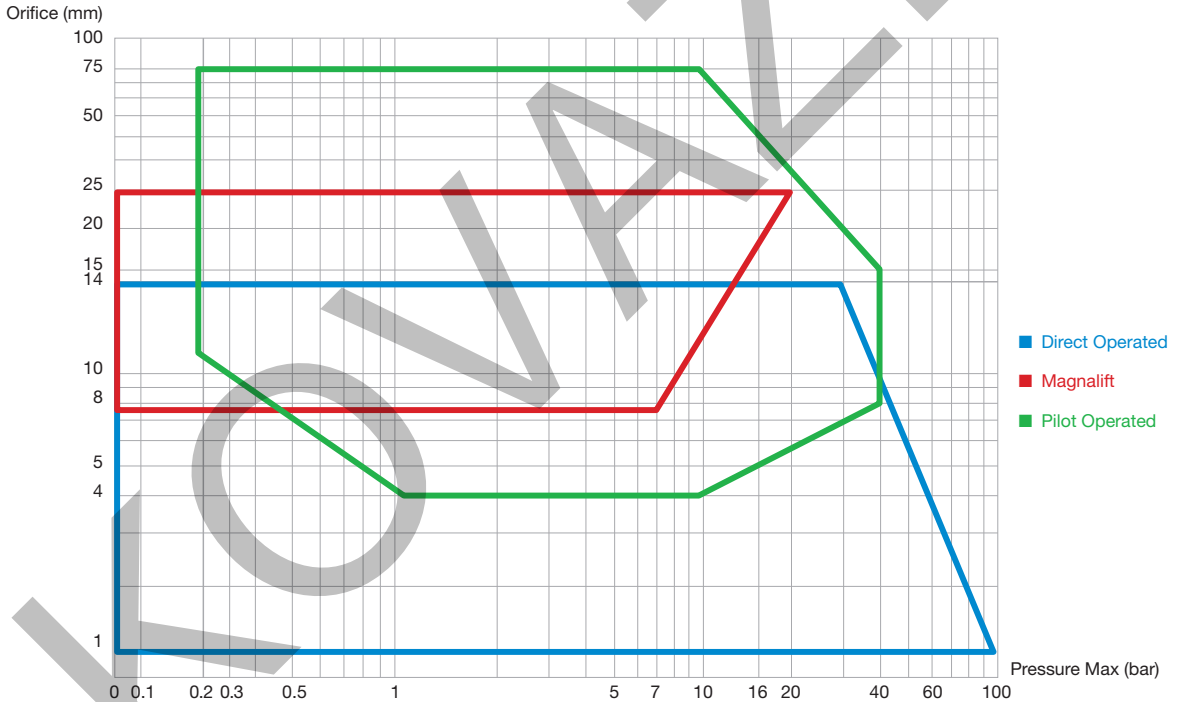

Areas of operation of Parker solenoid valves.

SIZING SOLENOID VALVES

The correct choice of solenoid valve is essential as it determines the regulation and performance required for practical application on a system. In order to decide on the exact type of solenoid valve, various parameters have to be known.

However the calculation method, based on the flow coefficient K_v , has proved highly practical as it can be determined on the basis of:

- Required flow rate
- Type of fluid and relative viscosity
- Flow resistance
- Specific gravity and temperature

This flow coefficient K_v is determined as defined in the VDI/VDE 2173 standards. It represents the flow of water in m³/h or L/min with a temperature from 5 to 30°C which passes through the solenoid valve with a pressure drop of 1 bar.

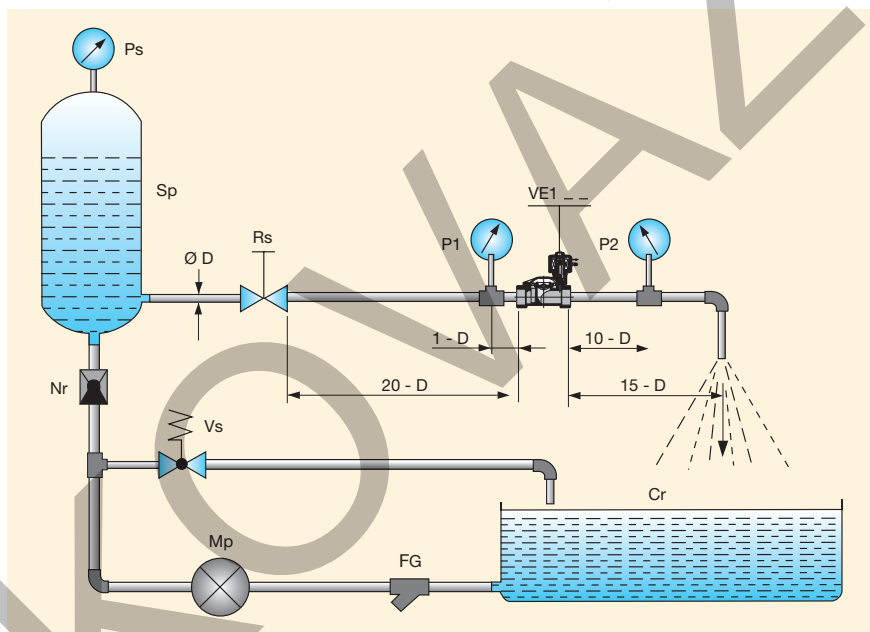

FG = Grid Filter Mp = Pump Vs = Safety Valve Nr = Check Valve Sp = Pressure Tank Ps = Static Pressure Manometer

Note:

The flow coefficient used in the USA is known as C_v and represents the water flow rate in US gallons per minute with a pressure drop ΔP of 1 psi.

To convert C_v in K_v and vice versa use:

$$1 K_v = 0.862 C_v$$

$$1 C_v = 1.16 K_v$$

After existing conditions have been converted into this factor K_v , the type of valve is found by referring to the pages in the related sections in this catalogue.

Parameters used for selecting the solenoid valve are in the table next page.

Consult conversion tables of the various units of measurement as defined by the ISO (International Standards Organisation) - I.S. (International System) set out in this catalogue.

FLOW AND PRESSURE RANGES

Pressure

symbol (P)
unit of measurement [bar]
Working pressure

Pressure drop

symbol (ΔP)
unit of measurement [bar]
Pressure difference between inlet (P_1) and outlet (P_2) of the solenoid valve when a medium is flowing through the valve ($\Delta P = P_1 - P_2$).

Flow coefficient

symbol (Kv)
unit of measurement [l/min]

Specific gravity of the medium

symbol (γ)
unit of measurement [Kg/dm³]

Temperature of the medium

symbol (t)
unit of measurement [°C]

Flow rate

- for liquids

symbol (Q)
unit of measurement [l/min]

- for gases

symbol (Qn)
unit of measurement [Nm³/h]

- for steam

symbol (Qv)
unit of measurement [Kg/h]

Specific volume

symbol (Vs)
unit of measurement [m³/Kg]

a) Solenoid valves for liquids:

Flow rate: $Q = K_v \cdot \sqrt{\frac{\Delta P}{\gamma}}$ where: Q = l/min
 ΔP = bar
 γ = Kg/dm³

Flow coefficient:
 $K_v = Q \cdot \sqrt{\frac{\gamma}{\Delta P}}$

In the case of liquids with viscosity greater than 3°E (22 cStokes) the Kv is modified according to the formula:

$$K_{v_1} = K_v + C \quad C = \frac{\delta \cdot \sqrt{K_v + 1}}{200 \cdot Q}$$

where C is the viscosity correction factor calculated by means of the formula:

where:

δ = kinematic viscosity of the fluid expressed in centistokes

Kv = flow rate factor of the solenoid valve

Q = flow rate in l/min

Pressure drop:

$$\Delta P = \gamma \cdot \left(\frac{Q}{K_v}\right)^2$$

b) Solenoid valves for gases:

If $\Delta P \leq 1/2 P_1$ use the following formulae:

$$\text{Flow rate: } Q_n = 514 \cdot K_v \cdot \sqrt{\frac{\Delta P \cdot P_2}{\gamma_n \cdot (273 + t)}}$$

where: $Q_n = \text{Nm}^3/\text{h}$ $P_1 = \text{bar}$ $P_2 = \text{bar}$

$$\text{Flow coefficient: } K_v = \frac{Q_n}{514} \cdot \sqrt{\frac{(273+t) \cdot \gamma_n}{\Delta P \cdot P_2}}$$

$t = \text{°C}$

$\gamma_n = \text{Kg/dm}^3$

$$\text{Pressure drop: } \Delta P = \frac{(273 + t) \cdot \gamma_n}{P_2} \cdot \frac{Q_n^2}{(514 \cdot K_v)^2}$$

If $\Delta P > 1/2 P_1$ use the following formula:

$$Q_n = 757 \cdot K_v \cdot \sqrt{\frac{\Delta P \cdot P_2}{(273 + t) \cdot \gamma_n}}$$

c) Solenoid valves for steam:

If $\Delta P \leq 1/2 P_1$ use the following formulae:

$$\text{Flow rate: } Q_v = 31,7 \cdot K_v \cdot \sqrt{\frac{\Delta P}{V_s}}$$

where: $Q_v = \text{Kg/h}$ $\Delta P = \text{bar}$ $V_s = \text{m}^3/\text{Kg}$

$$\text{Flow coefficient: } K_v = \frac{Q_v}{31,7} \cdot \sqrt{\frac{V_s}{\Delta P}}$$

$$\text{Pressure drop: } \Delta P = V_s \cdot \frac{Q_v^2}{(31,7 \cdot K_v)^2}$$

If $\Delta P > 1/2 P_1$ use the following formula:

$$Q_v = 22,4 \cdot K_v \cdot \sqrt{\frac{P_1}{V_s}}$$

Notes:

1) Should the value ΔP not be specified, use the following, which is based on experience:

- For liquids only in the case of free discharge $\Delta P = 90\%$ of the input pressure (P_1).
- For gases never use a ΔP of more than 50% of the absolute inlet pressure, since the excessive pressure drop may cause an irregular flow rate. In most cases, ΔP can be considered as 10% of the input pressure.

2) Specific volume value (V_s) for dry saturated steam, see the table in diagram 3.

FLOW RATE FOR LIQUIDS

The liquid flow through a pipe or a valve is given by:

$$Q = K_v \cdot \sqrt{\frac{\Delta P}{\gamma}}$$

- Where
- Q = Flow [l/min]
 - ΔP = Differential Pressure [bar]
 - γ = Density of the fluid [kg/dm³]
(water $\gamma = 1$ [kg/dm³])
 - k_v = Flow Factor [l/min]

Flow factor k_v:

The k_v flow factor of a valve is defined as the flow rate of water in litres per minute with a pressure drop of 1 bar across the valve.

Valve manufacturerers use different definitions for k_v. It may be expressed in l/h or m³/h.

Care should therefore be taken when comparing values.

Maximum flow rate Q_{max}.

For particular 2-way valves the maximum flow must be limited for reasons of mechanical resistance and durability.

A very high flow velocity may dislocate a poppet sealing or a diaphragm.

Maximum flow rates are indicated in the catalogue.

Flow factors

K _v l/min	K _V m ³ /h	Q _n l/min
-------------------------	-------------------------------------	-------------------------

NORMALLY CLOSED

Port size	Orifice Ø	Flow factors			Operating Pressure Differential		Fluid Temp.		Seat Seal	Parker Valves			Power		Coil Group	Dwg. No.
		K _v l/min	K _V m ³ /h	Q _n l/min	Min	Max(MOPD)	Min	Max		Valve Ref.	Housing Ref.	Coil Ref.	AC	DC		
BSP	mm				bar	AC bar DC bar	°C	°C					AC W	DC W		

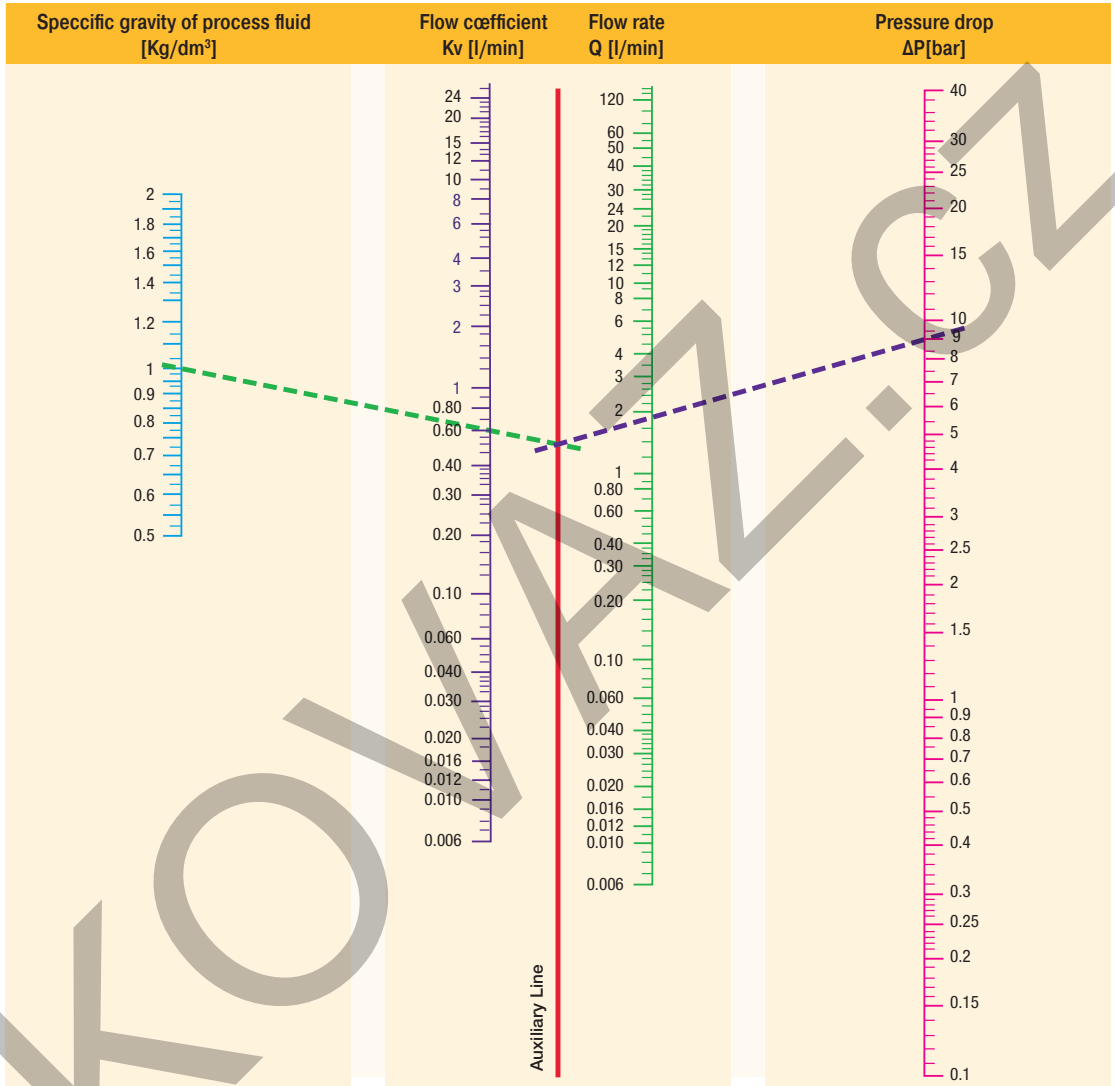

Monogram for liquid flow calculation

Specific gravity of the most common fluids (= Kg/dm ³) - (t = 15°C - P = 760 mm Hg)			
Acetone	0.76	Benzenol	0.90
Water	1.00	Beer	1.02
Sea water	1.02	Hexane	0.66
Ethyl alcohol	0.79	Ethane	0.68
Methyl alcohol	0.81	Diesel oil	0.70
Petrol	0.68	Milk	1.03
		Naphtha	0.76
		Pentane	0.63
		Vegetable oil	0.92
		Hydraulic oil	0.92
		Wine	0.95

FLOW RATE FOR GASES

The gas flow through a valve is given by:

$$Q = C \cdot P_1 \cdot k_T \cdot \omega \cdot \gamma_{\text{air}} / \gamma_{\text{gas}}$$

Where

- Q = Flow Rate [dm³/s]
- C = Conductance [dm³/s.bar]
- P₁ = Inlet Pressure [bar abs]
- γ = Specific Weight [Kg/dm³]
- k_T = Temperature Correction Factor

$$\omega = \sqrt{1 - \frac{P_2/P_1 - b}{1 - b}} \quad k_T = \sqrt{\frac{293}{273 + \text{Temp. } ^\circ\text{C}}}$$

Nominal Flow Q_n:

Calculations can be made with specific flow factors based on the CETOP RP 50P standard. For practical purposes and ease of valve selection the catalogue shows the nominal flow Q_n. The nominal flow Q_n is defined as the flow rate (L/min) of air across the valve when the inlet pressure P₁ = 6 bar and the pressure drop ΔP = 1 bar.

N.B.

The values of the flow factors and flow rates mentioned in catalogues are subject to +/-15% tolerances.

Pneumatic application: $\gamma_{\text{air}} / \gamma_{\text{gas}} = 1$

- a) Choked flow conditions $P_2 \leq b \cdot P_1$
in this case $\omega = 1 \rightarrow Q = C \cdot P_1 \cdot k_T$
- b) Free flow conditions $P_2 > b \cdot P_1$
in this case $\rightarrow Q = C \cdot P_1 \cdot k_T \cdot \omega$

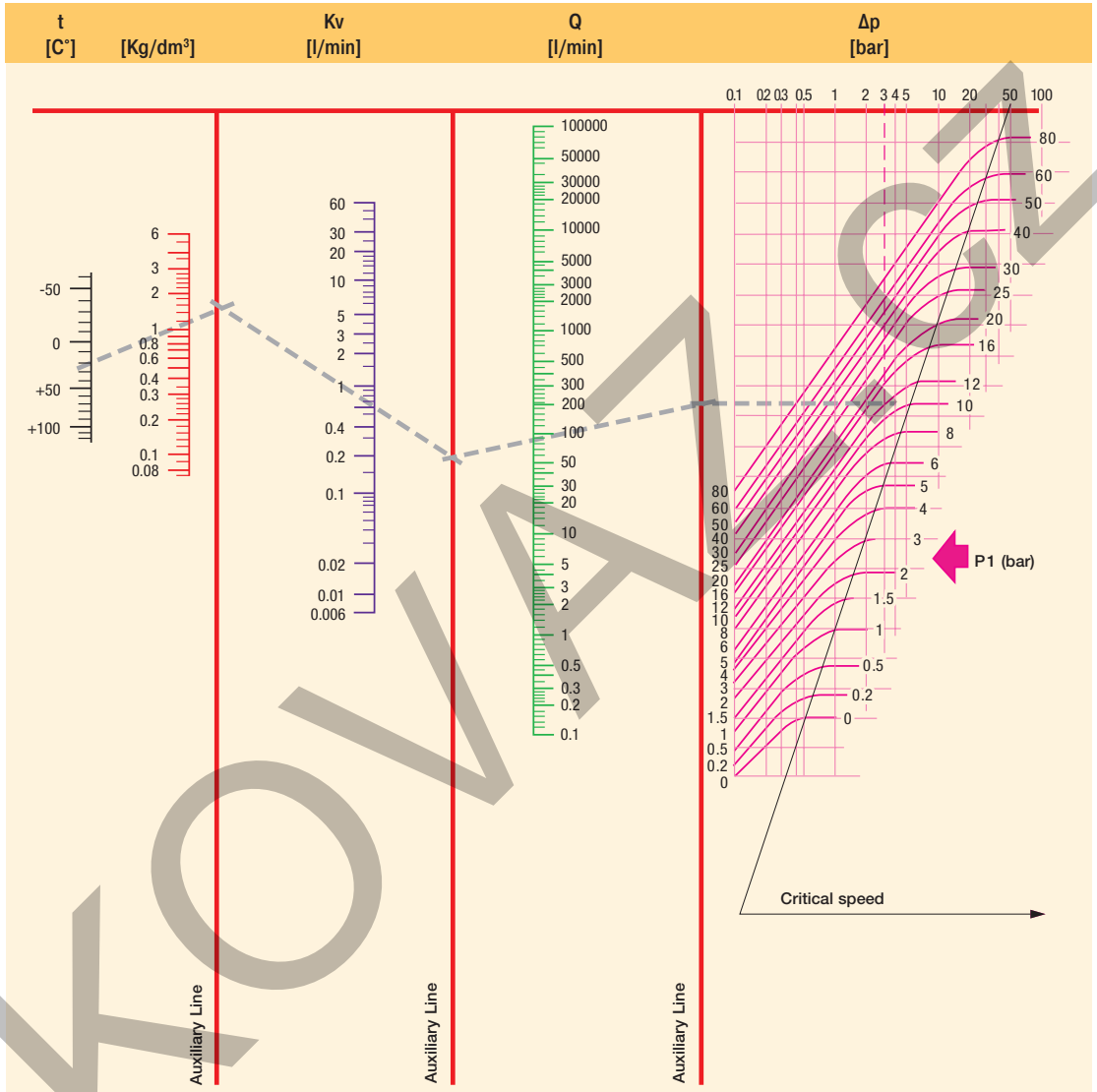

t = Fluid Temperature γ_N = Specific Gravity Kv = Flow Coefficient Qn = Flow Rate Δp = Pressure Drop P₁ = Inlet Pressure

Specific gravity of the most common gases ($\gamma = \text{Kg/m}^3$) - (t = 0°C - P = 760mm Hg)

Acetylene	1.176	Helium	0.179	Natural gas	0.723
Carbon dioxide	1.965	Ethane	1.035	Methane	0.722
Air	1.293	Ethylene	1.259	Carbon monoxide	1.250
Argon	1.780	Hydrogen	0.089	Oxygen	1.429
Nitrogen	1.255			Propane	1.520
Butane	2.000			Steam	0.805

TECHNICAL INFORMATION

Diagram 3 for Dry Saturated Steam

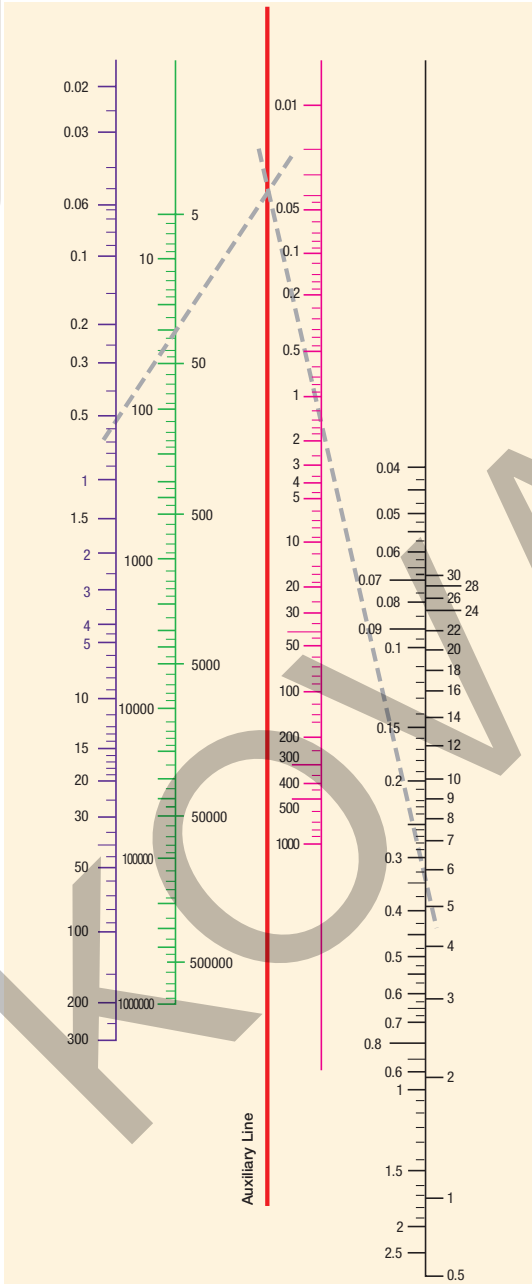

Steam (Dry Saturated) Data

P ₂ bar	Temp. °C	Vs m ³ /Kg	P ₂ bar	Temp. °C	Vs m ³ /Kg
0.01	6.6	131.600	10.00	179.0	0.200
0.02	17.1	68.300	110.00	183.2	0.181
0.03	23.7	46.500	120.00	187.1	0.176
0.04	28.6	35.500	13.00	190.7	0.155
0.05	32.5	28.700	14.00	194.1	0.144
0.06	35.8	24.200	15.00	197.4	0.135
0.08	41.1	18.500	16.00	200.4	0.126
0.10	45.4	15.000	17.00	203.4	0.119
0.20	59.7	7.800	18.00	206.2	0.113
0.30	68.7	5.330	19.00	208.8	0.107
0.40	75.4	4.070	20.00	211.4	0.102
0.50	80.9	3.300	22.00	216.2	0.093
0.60	85.5	2.790	24.00	220.8	0.085
0.70	89.5	2.410	26.00	225.0	0.079
0.80	93.0	2.130	28.00	229.0	0.073
0.90	96.2	1.910	30.00	232.8	0.068
1.00	99.1	1.730	32.00	236.4	0.064
1.50	110.8	1.180	34.00	239.8	0.060
2.00	119.6	0.900	36.00	243.1	0.057
2.50	126.8	0.730	38.00	246.2	0.053
3.00	132.9	0.620	40.00	249.2	0.051
3.50	138.2	0.530	45.00	256.2	0.045
4.00	142.9	0.470	50.00	262.7	0.040
4.50	147.2	0.420	55.00	268.7	0.036
5.00	151.1	0.380	60.00	274.3	0.033
5.50	154.7	0.350	65.00	279.6	0.030
6.00	158.1	0.320	70.00	284.5	0.028
6.50	161.2	0.300	80.00	293.6	0.024
7.00	164.2	0.280	90.00	301.9	0.021
7.50	167.0	0.260	100.00	309.5	0.018
8.00	169.6	0.250	150.00	340.5	0.011
8.50	172.1	0.230	200.00	364.2	0.006
9.00	174.5	0.220	225.00	374.0	0.003
9.50	176.8	0.210			

Kv = Flow Coefficient

Qv = Flow Rate

Δp = Pressure Drop

Vs = Specific Volume

P₂ = Outlet Pressure

VISCOSITY CONVERSION TABLE

Centistokes cStokes mm ² /S	°Engler °E	Saybolt Universal Second SSU	Rewood Second N°1 SRW N°1
1	1	-	-
12	2	65	55
22	3	100	90
30	4	140	120
28	5	175	155
45	6	210	185
60	8	275	245
75	10	345	305
90	12	415	370
115	15	525	465
150	20	685	610
200	26	910	810
300	39	1 385	1 215
400	53	1 820	1 620
500	66	2 275	2 025
750	97	3 365	2 995
1 500	197	6 820	6 075

OTHER USEFUL FORMULAS

Formulas:

°C = (°F - 32) x 5/9
 °F = (°C x 9/5) + 32
 m³/h = l/min x 0.06
 l/min = m³/h x 16,67
 m³/sec = m³/h x 2,778 x 10⁻⁴
 m³/sec = l/min x 1,667 x 10⁻⁵

Examples:

(167°F-32) x 5/9 = 75°C
 (30°C x 9/5) + 32 = 86°F
 100 l/min x 0.06 = 6 m³/h
 9 m³/h x 16,67 = 150 l/min
 18.000 m³/h x 2.778 x 10⁻⁴ = 5 m³/sec
479.904 l/min x 1.667 x 10⁻⁵ = 8 m³/sec

TABLE OF SUB-BASES FOR VALVES (Examples)

Port Size	Part Number	Material	Kit Including	Compatible with Valves with
1/8" G	XGSPG1	AISI 304	fixing screws	any < 3.0 mm orifice
1/4" G	XGSPG2	AISI 304	fixing screws	any < 3.0 mm orifice
1/4" G	XGSPG3	AISI 304	fixing screws	4.0 mm to 5 mm orifice

Liquipure® Adapter

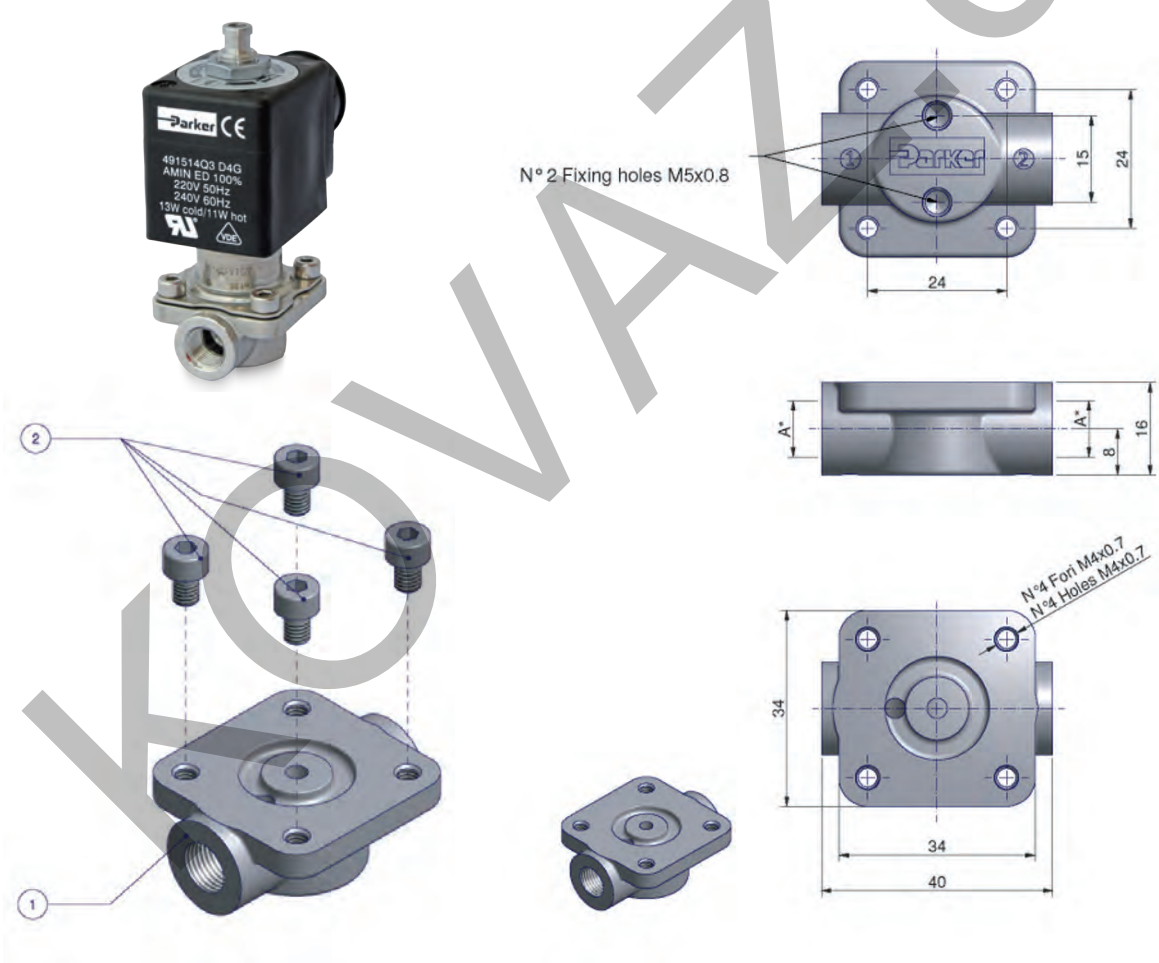

All dimensions are in mm

TABLE OF VOLTAGE CODES FOR COILS AND ELECTRICAL PARTS

This table is showing the most commonly used voltage codes, for other voltages, please ask us.

VOLTAGE CODES			C1	C2	N7	L8	C4	C5	C7	E6	P1	A5	0A	S5	P2	1P	6J	0P	P3	K8	
Coil	Group	Sub-Group	12 DC	24 DC	28 DC	30 DC	48 DC	110 DC	196 DC	220 DC	100/50	100/50-60	110/50	110-115/50	110-115/50 120/60	110/50-60	110-115/50-60	110-115/60	100/50-115/60	110/50-120/60	115/60
481045	1.1	-	•	•			•	•													
481180	1.1	-	•	•				•													
481530	1.1	-	•	•																	
482605	1.1	-	•	•																	
482606	1.1	-	•	•			•	•													
483590	1.1	-																			
488143	1.1	-																			
488980	1.1	-	•	•			•	•													
492912	1.1	-		•																	
492919	1.1	-		•																	
495865	1.1	-		•			•														
496131	1.2	-	•	•			•	•													•
496637	1.2	-	•	•			•	•													•
WB4.5	1.3	-									•	•									•
WB5.0	1.3	-	•	•				•													
WB8.0	1.3	-																			•
481000	2.0	2.1	•	•			•	•	•									•			•
481865	2.0	2.1	•	•			•	•	•												•
482635	2.0	2.1																			
482725	2.0	2.1	•	•																	•
483371	2.0	2.1	•	•			•	•	•												
483510	2.0	2.1																			
483520	2.0	2.1																			
485100	2.0	2.1		•						•											
488553	2.0	2.1																			
488947	2.0	2.1																			
491514	2.0	2.1	•	•		•															•
492070	2.0	2.1	•	•			•	•													•
492190	2.0	2.1	•	•			•	•	•												•
492453	2.0	2.1	•	•			•	•													
492670	2.0	2.1	•	•			•	•													
492726	2.0	2.1		•																	
493640	2.0	2.1		•			•														•
494040	2.0	2.1		•																	
495870	2.0	2.1		•			•	•													
495905	2.0	2.1		•			•	•													•
496081	2.0	2.1	•	•																	
496082	2.0	2.1	•	•																	
496110	2.0	2.1																			•
HZ10	2.0	2.1																			•
481044	2.0	2.2																			•
483816	2.0	2.2	•	•																	
486265	2.0	2.2	•	•			•														•
492425	2.0	2.2	•	•																	
492727	2.0	2.2	•	•																	
495880	2.0	2.2		•																	
496155	2.0	2.2		•																	
HZ11	2.0	2.2	•	•			•														•
482730	3.0	-		•																	•
482735	3.0	-		•			•														
495875	3.0	2.1		•																	

TABLE OF VOLTAGE CODES FOR COILS AND ELECTRICAL PARTS

This table is showing the most commonly used voltage codes, for other voltages, please ask us.

VOLTAGE CODES			C1	C2	N7	L8	C4	C5	C7	E6	P1	A5	0A	S5	P2	1P	6J	0P	P3	K8		
Coil	Group	Sub-Group	12 DC	24 DC	28 DC	30 DC	48 DC	110 DC	196 DC	220 DC	100/50	100/50-60	110/50	110-115/50	110-115/50 120/60	110/50-60	110-115/50-60	110-115/60	100/50-115/60	110/50-120/60	115/60	
484990	4.0	-																				
485400	4.0	-	•	•			•	•														
495915	4.0	-		•			•	•														
482740	6.0	-		•			•	•														
482745	6.0	-		•			•	•														
495900	6.0	-	•	•			•	•														•
496125	6.0	-		•			•	•														
483580.01	7.0	-			•																	
488650.01	7.0	-			•																	
488660.01	7.0	-			•																	
488670.01	7.0	-			•																	
490885	7.0	-				•																
490890	7.0	-			•	•																
495910	8.0	-			•																	
492210	9.0	-		•																		
492965.01	9.0	-			•																	
496565	9.0	-			•																	
492300	10.1	-	•	•			•	•		•						•						
492310	10.1	-	•	•			•	•		•							•					
496560	10.1	-		•			•	•									•					
496800	10.1	-		•			•	•									•					
496800.02	10.1	-		•			•	•									•					
496895	10.1	-		•			•	•									•					
496555	10.2	-		•			•	•									•					
496700	10.2	-		•			•	•									•					
496700.02	10.2	-		•			•	•									•					
497105	10.3	-	•	•			•	•									•					
492335	12.0	-				•																
482870.01	12.0	-			•																	
495294	13.0	-	•	•																		
496193	13.0	-	•	•																		
483824	14.1	-																				
483764	14.2	-																				
483541	14.3	-																				

INDEX BY COIL REFERENCE

Coil Reference	Coil Group	Designation	Power DC Pn (W)	Power AC Pn (W)	Ambient Temperature	UL	Degree of Protection	ATEX or NEMA 4X Protection (Gas)	Page
481000	2.0/2.1	Coil with screw terminal, 40 mm	8.0	8.0	-40°C to +50°C	-	IP 44 to 67	-	434
481044	2.0/2.2	Coil with screw terminal High power, 40 mm	-	14.0	-40°C to +50°C	-	IP 44 to 67	-	435
481180	1.1	Coil for DIN plug connection, 22 mm	5.0	4.0	-40°C to +50°C	-	IP65	-	425
481865	2.0 / 2.1	COILS FOR DIN PLUG CONNECTION 32 mm	9.0	8.0	-40°C to +50°C	-	IP65	-	418
482605	1.1	Explosion proof encapsulated electrical part "mb", 32 mm	5.0	4.0	-40°C to +65°C / +40°C	-	IP65	II 2 G Ex mb IIC T4/T5	453
482606	1.1	Explosion proof encapsulated electrical part "mb", low power, 32 mm	2.5	2.0	-40°C to +65°C/+35°C	-	IP65	II 2 G Ex mb IIC T4/T5	453
482730	3.0	COILS FOR DIN PLUG CONNECTION, REDUCED POWER, 32 mm	7.0	6.0	-40°C to +50°C	-	IP65	-	420
482740	6.0	COILS FOR DIN PLUG CONNECTION, low power, 32 mm	1.6	-	-40°C to +50°C	-	IP65	-	421
483371	2.0/2.1	Explosion proof increased safety electrical part "eb", 50 mm	8.0	8.0	-40°C to +65°C	-	IP67	II 2 G Ex eb IIC T4	462
483510	2.0 / 2.1	COILS FOR DIN PLUG CONNECTION 32 mm	-	9.0	-40°C to +50°C	-	IP65	-	418
483520	2.0/2.1	Coil with screw terminal, double frequency, 40 mm	-	9.0	-40°C to +50°C	-	IP 44 to 67	-	434
483541	14.3	Coil with screw terminal, high temperature-high power, 40 mm	20.0	20.0	-40°C to +50°C	-	IP 44 to 67	-	438
483590	1.1	Coil for DIN plug connection, double frequency, 22 mm	-	3.0	-40°C to +50°C	-	IP65	-	427
483764	14.2	Coil for DIN plug connection, UL recognized	-	9.0	-40°C to +50°C	-	IP65	-	423
483816	2.2	Coil for DIN plug connection for Jet Valves, 32 mm	14.0	14.0	-40°C to +50°C	-	IP65	-	424
483824	14.1	Coil with screw terminal, high temperature-high power, 40 mm	19.0	19.0	-40°C to +50°C	-	IP 44 to 67	-	437
484990	4.0	Coil with screw terminal, bistable, for impulse applications, 40 mm	-	11.0	-40°C to +50°C	-	IP 44 to 67	-	440
485400	4.0	Coil with screw terminal, bistable, for impulse applications, 40 mm	13.0	-	-40°C to +50°C	-	IP 44 to 67	-	440
486265	2.0/2.2	Coil with screw terminal, high temperature-high power, 40 mm	14.0	14.0	-40°C to +50°C	-	IP 44 to 67	-	436
488143	1.1	Coil for DIN plug connection, double frequency, 22 mm	-	2.5	-40°C to +50°C	-	IP65	-	428
488553	2.0/2.1	Coil with screw terminal, double frequency, H class, 40 mm	-	9.0	-40°C to +50°C	-	IP 44 to 67	-	439
488980	1.1	Coil for DIN plug connection, low power, 22 mm	2.5	2.0	-40°C to +50°C	-	IP65	-	425
490885	7.0	Explosion proof intrinsically safe electrical part, "NEMA", 50 mm	3.0	-	-40°C to +60°C	-	NEMA 4 - 4X	Cl. I, Div. I, Gr. A, B, C, D	470
491514	2.0/2.1	COILS FOR DIN PLUG CONNECTION, 32 mm, UL	-	11.0	-40°C to +50°C	-	IP65	-	422
492070	2.0/2.1	Explosion proof encapsulated electrical part "mb", with water proof metal housing, 50mm (with 3 m cable length)	8.0	9.0	-40°C to +65°C	-	IP67	II 2 G Ex mb IIC T4/T5	454
492190	2.0/2.1	Explosion proof increased safety and encapsulated electrical part "eb", 50 mm	9.0	11.0	-40°C to +75°C	-	IP66	II 2 G Ex eb mb IIC T3/T4	465
492210	9.0	Explosion proof increased safety and encapsulated electrical part "eb", "Booster", 50 mm	1.0 to 1.8	-	-40°C to +75°C	-	IP66	II 2 G Ex eb mb IIC T5/T6	464
492310	10.1	Explosion proof increased safety and encapsulated electrical part "eb", 50 mm	6.0	6.0	-40°C to +75°C	-	IP66	II 2 G Ex eb mb IIC T4/T5	463
492425	2.0/2.2	COILS FOR DIN PLUG CONNECTION, HIGH TEMPERATURE, 32 mm	14.0	14.0	-40°C to +50°C	-	IP65	-	419
492453	2.0/2.1	COILS FOR DIN PLUG CONNECTION, HIGH TEMPERATURE, 32 mm	9.0	8.0	-40°C to +50°C	-	IP65	-	419
492912	1.1	Coil for DIN plug connection, 22 mm	4.0	3.0	-40°C to +50°C	-	IP65	-	426
493640	2.0/2.1	Flame proof encapsulated electrical part "db mb", double frequency	8.0	8.0	-40°C to +75°C	-	IP65	II 2 G Ex db mb IIC T4/T5	461
494040	2.0/2.1	Explosion proof increased safety electrical part "eb", 50 mm	8.0	8.0	-40°C to +90°C	-	IP67	II 2 G Ex eb IIC T3/T4	462
495294	13.0	Coil with ISO-DIN connector, 12-24VDC for transportation applications, 32 mm	9.0	-	-40°C to +120°C	-	IP69K	-	441
495865	1.1	Explosion proof electrical part "nAc nCc", low power, 22 mm	2.5	2.0	-40°C to +50°C	-	IP65	II 3 G Ex nAc nCc IIC T5	444
495870	2.0/2.1	Explosion proof electrical part "nAc nCc", 32 mm	9.0	8.0	-40°C to +50°C	-	IP65	II 3 G Ex nAc nCc IIC T3/T4	446
495875	3.0	Explosion proof electrical part "nAc nCc", 32 mm	7.0	6.0	-40°C to +50°C	-	IP65	II 3 G Ex nAc nCc IIC T3/T4	448
495880	2.0/2.2	Explosion proof electrical part "nAc nCc", 32 mm	14.0	14.0	-40°C to +50°C	-	IP65	II 3 G Ex nAc nCc IIC T3	449
495900	6.0	Flame proof encapsulated electrical part "db mb", low power, 37 mm	2.0	2.5	-40°C to +65°C	-	IP67	II 2 G Ex db mb IIC T4 / T5/T6	457

INDEX BY COIL REFERENCE

Coil Reference	Coil Group	Designation	Power DC Pn (W)	Power AC Pn (W)	Ambient Temperature	UL	Degree of Protection	ATEX or NEMA 4X Protection (Gas)	Page
495905	2.0/2.1	Flame proof encapsulated electrical part "db mb", 37 mm	8.0	8.0	-40°C to +65°C	-	IP67	II 2 G Ex db mb IIC T4	458
495910	8.0	Explosion proof intrinsically safe electrical part "ia", "booster", 37 mm	0.3 to 1.2	-	-40°C to +80°C	-	IP67	II 1 G Ex ia IIC T4/T5/T6	467
495915	4.0	Explosion proof increased safety electrical part "nAc nCc", 50 mm	13.0	11.0	-40°C to +65°C	-	IP67	II 3 G Ex nAc nCc IIC T3	450
496081	2.0/2.1	Coil with flying leads, IP 67, 32 mm	9.0	9.0	-40°C to +50°C	-	IP67	-	432
496110	2.0/2.1	Explosion proof electrical part "nAc nCc", 32 mm	-	9.0	-40°C to +50°C	-	IP65	II 3 G Ex nAc nCc IIC T3/T4	446
496125	6.0	Explosion proof electrical part "nAc nCc", low power, 32 mm	1.6	-	-40°C to +50°C	-	IP65	II 3 G Ex nAc nCc IIC T5/T6	447
496131	1.2	Coil for DIN plug connection, double frequency, 22 mm	3.0	3.0	-40°C to +50°C	-	IP65	-	429
496155	2.0/2.2	Explosion proof increased safety electrical part "nAc nCc", 50 mm	14.0	14.0	-40°C to +65°C	-	IP67	II 3 G Ex nAc nCc IIC T3	451
496193	13.0	Coil with ISO-DIN connector, 12-24VDC, for transportation applications, 32 mm	9.0	-	-40°C to +120°C	-	IP69K	-	441
496482	1.2	Coil for DIN plug connection, double frequency coil, 22 mm	3.0	3.0	-40°C to +50°C	-	IP65	-	430
496555	10.2	Flame proof encapsulated electrical part "db mb", 37 mm	6.0	6.0	-40°C to +65°C	-	IP67	II 2 G Ex db mb IIC T4/T5/T6	459
496560	10.1	Flame proof encapsulated electrical part "db mb", 37 mm	8.0	8.0	-40°C to +65°C	-	IP67	II 2 G Ex db mb IIC T4	459
496565	9.0	Explosion proof intrinsically safe electrical part "ia", "Booster", 37 mm	0.77 to 2.58	-	-40°C to +80°C	-	IP67	II 1 G Ex ia IIC T4/T5/T6	468
496637	1.2	Explosion proof electrical part "nAc nCc", double frequency, 22 mm	3.0	3.0	-20°C to +50°C	-	IP65	II 3 D Ex TC IIC T 95°C	445
496700	10.2	Flame proof encapsulated electrical part "db mb", 37 mm	6.0	6.0	-40°C to +65°C	-	IP67	II 2 G Ex db mb IIC T4 / T5 / T6	460
496800	10.1	Flame proof encapsulated electrical part "db mb", 37 mm	8.0	8.0	-40°C to +65°C	-	IP67	II 2 G Ex db mb IIC T4	460
496895	10.1	Coil for DIN plug connection for oil and gas, 37 mm	8.0	8.0	-40°C to +50°C	-	IP65	-	431
497105	10.3	Flame proof stainless steel electrical part "db", M20x1.5	8.0	8.0	-50°C to +80°C / +60°C / +40°C	-	IP66	II 2 G Ex db IIC T4/T5/T6	452
482606.160	1.1	Explosion proof encapsulated electrical part "mb", low power, 32 mm	2.5	2.0	-40°C to +65°C / +35°C	-	IP65	II 2 G Ex mb IIC T4/T5	453
492070.160	2.0/2.1	Explosion proof encapsulated electrical part "mb", with water proof metal housing, 50mm (with 6 m cable length)	8.0	9.0	-40°C to +65°C	-	IP67	II 2 G Ex mb IIC T4/T5	454
483580.01	7.0	Explosion proof intrinsically safe electrical part "ia", 32 mm	3.0	-	-40°C to +55°C	-	IP65	II 1 G Ex ia IIC T6	466
483960.01	7.0	Explosion proof intrinsically safe electrical part "ia", 32 mm	3.0	-	-40°C to +55°C	-	IP65	II 1 G Ex ia IIC T6	466
488650.01	7.0	Explosion proof intrinsically safe electrical part "ia", 50 mm	0.3 to 3.0	-	-40°C to +65°C	-	IP66	II 1 G Ex ia IIC T6	470
492965.01	9.0	Explosion proof intrinsically safe electrical part "ia", "Booster", 50 mm (stainless steel fixation)	0.3 to 2.3	-	-40°C to +65°C	-	IP66	II 1 G Ex ia IIC T6	469
492965.02	9.0	Explosion proof intrinsically safe electrical part "ia", "Booster", 50 mm (Plastic fixation)	0.3 to 2.3	-	-40°C to +65°C	-	IP66	II 1 G Ex ia IIC T6	469
493640.60*	2.0/2.1	Flame proof encapsulated electrical part "db mb", double frequency	8.0	8.0	-40°C to +75°C	-	IP65	II 2 G Ex db mb IIC T4/T5	461
495905.05*	2.0/2.1	Flame proof encapsulated electrical part "db mb", 37 mm	8.0	8.0	-40°C to +65°C	-	IP67	II 2 G Ex db mb IIC T4	458
496700.02	10.2	Flame proof encapsulated electrical part "db mb", 37 mm	6.0	6.0	-40°C to +65°C	-	IP67	II 2 G Ex db mb IIC T4 / T5 / T6	460
496800.02	10.1	Flame proof encapsulated electrical part "db mb", 37 mm	8.0	8.0	-40°C to +65°C	-	IP67	II 2 G Ex db mb IIC T4	460
497105.02	10.3	Flame proof stainless steel electrical part "db", NPT 1/2"	8.0	8.0	-50°C to +80°C / +60°C / +40°C	-	IP66	II 2 G Ex db IIC T4/T5/T6	452
HZ10	2.0/2.1	Explosion proof encapsulated electrical part "mb", double frequency	8.0	8.0	-40°C to +85°C	-	IP65	II 2 G Ex mb IIC T3/T4/T5	455
HZ11		Explosion proof encapsulated electrical part "mb", double frequency	14.0	14.0	-40°C to +85°C	-	IP65	II 2 G Ex mb IIC T3/T4/T5	456

INDEX BY COIL GROUP

Coil Group	Coil Reference	Designation	Power DC Pn (W)	Power AC Pn (W)	Ambient Temperature	UL	Degree of Protection	ATEX or NEMA 4X Protection (Gas)	Page
1.1	481180	COIL FOR DIN PLUG CONNECTION, 22 MM	5.0	4.0	-40°C TO +50°C	-	IP65	-	425
1.1	483590	COIL FOR DIN PLUG CONNECTION, DOUBLE FREQUENCY, 22 MM	-	3.0	-40°C TO +50°C	-	IP65	-	427
1.1	488143	COIL FOR DIN PLUG CONNECTION, DOUBLE FREQUENCY, 22 MM	-	2.5	-40°C TO +50°C	-	IP65	-	428
1.1	495865	EXPLOSION PROOF ELECTRICAL PART "NAC NCC", LOW POWER, 22 MM	2.5	2.0	-40°C TO +50°C	-	IP65	II 3 G EX nAc nCc IIC T5	444
1.1	482605	EXPLOSION PROOF ENCAPSULATED ELECTRICAL PART "MB", 32 MM	5.0	4.0	-40°C TO +65°C / +40°C	-	IP65	II 2 G EX MB IIC T4/T5	453
1.1	482606	EXPLOSION PROOF ENCAPSULATED ELECTRICAL PART "MB", LOW POWER, 32 MM	2.5	2.0	-40°C TO +65°C/+35°C	-	IP65	II 2 G EX MB IIC T4/T5	453
1.1	482606.160	EXPLOSION PROOF ENCAPSULATED ELECTRICAL PART "MB", LOW POWER, 32 MM	2.5	2.0	-40°C TO +65°C/+35°C	-	IP65	II 2 G EX MB IIC T4/T5	453
1.1	488980	COIL FOR DIN PLUG CONNECTION, LOW POWER, 22 MM	2.5	2.0	-40°C TO +50°C	-	IP65	-	425
1.1	492912	COIL FOR DIN PLUG CONNECTION, 22 MM	4.0	3.0	-40°C TO +50°C	-	IP65	-	426
1.2	496482	COIL FOR DIN PLUG CONNECTION, DOUBLE FREQUENCY COIL, 22 MM	3.0	3.0	-40°C TO +50°C	-	IP65	-	430
1.2	496637	EXPLOSION PROOF ELECTRICAL PART "NAC NCC", DOUBLE FREQUENCY, 22 MM	3.0	3.0	-20°C TO +50°C	-	IP65	II 3 D EX TC IIIC T 95°C	445
1.2	496131	COIL FOR DIN PLUG CONNECTION, DOUBLE FREQUENCY, 22 MM	3.0	3.0	-40°C TO +50°C	-	IP65	-	429
2.0/2.1	481865	COILS FOR DIN PLUG CONNECTION 32 MM	9.0	8.0	-40°C TO +50°C	-	IP65	-	418
2.0/2.1	483510	COILS FOR DIN PLUG CONNECTION 32 MM	-	9.0	-40°C TO +50°C	-	IP65	-	418
2.0/2.1	492453	COILS FOR DIN PLUG CONNECTION, HIGH TEMPERATURE, 32 MM	9.0	8.0	-40°C TO +50°C	-	IP65	-	419
2.0/2.1	491514	COILS FOR DIN PLUG CONNECTION, 32 MM, UL	-	11.0	-40°C TO +50°C	-	IP65	-	422
2.0/2.1	496081	COIL WITH FLYING LEADS, IP 67, 32 MM	9.0	9.0	-40°C TO +50°C	-	IP67	-	432
2.0/2.1	481000	COIL WITH SCREW TERMINAL, 40 MM	8.0	8.0	-40°C TO +50°C	-	IP 44 TO 67	-	434
2.0/2.1	483520	COIL WITH SCREW TERMINAL, DOUBLE FREQUENCY, 40 MM	-	9.0	-40°C TO +50°C	-	IP 44 TO 67	-	434
2.0/2.1	495870	EXPLOSION PROOF ELECTRICAL PART "NAC NCC", 32 MM	9.0	8.0	-40°C TO +50°C	-	IP65	II 3 G EX NAC NCC IIC T3/T4	446
2.0/2.1	496110	EXPLOSION PROOF ELECTRICAL PART "NAC NCC", 32 MM	-	9.0	-40°C TO +50°C	-	IP65	II 3 G EX NAC NCC IIC T3/T4	446
2.0/2.1	492070	EXPLOSION PROOF ENCAPSULATED ELECTRICAL PART "MB", WITH WATER PROOF METAL HOUSING, 50MM (WITH 3 M CABLE LENGTH)	8.0	9.0	-40°C TO +65°C	-	IP67	II 2 G EX MB IIC T4/T5	454
2.0/2.1	492070.60	EXPLOSION PROOF ENCAPSULATED ELECTRICAL PART "MB", WITH WATER PROOF METAL HOUSING, 50MM (WITH 6 M CABLE LENGTH)	8.0	9.0	-40°C TO +65°C	-	IP67	II 2 G EX MB IIC T4/T5	454
2.0/2.1	HZ10	EXPLOSION PROOF ENCAPSULATED ELECTRICAL PART "MB", DOUBLE FREQUENCY	8.0	8.0	-40°C TO +85°C	-	IP65	II 2 G EX MB IIC T3/T4/T5	455
2.0/2.1	HZ11	EXPLOSION PROOF ENCAPSULATED ELECTRICAL PART "MB", DOUBLE FREQUENCY	14.0	14.0	-40°C TO +85°C	-	IP65	II 2 G EX MB IIC T3/T4/T5	456
2.0/2.1	495905	FLAME PROOF ENCAPSULATED ELECTRICAL PART "DB MB", 37 MM	8.0	8.0	-40°C TO +65°C	-	IP67	II 2 G EX DB MB IIC T4	458
2.0/2.1	495905.05*	FLAME PROOF ENCAPSULATED ELECTRICAL PART "DB MB", 37 MM	8.0	8.0	-40°C TO +65°C	-	IP67	II 2 G EX DB MB IIC T4	458
2.0/2.1	493640	FLAME PROOF ENCAPSULATED ELECTRICAL PART "DB MB", DOUBLE FREQUENCY	8.0	8.0	-40°C TO +75°C	-	IP65	II 2 G EX DB MB IIC T4/T5	461
2.0/2.1	493640.60*	FLAME PROOF ENCAPSULATED ELECTRICAL PART "DB MB", DOUBLE FREQUENCY	8.0	8.0	-40°C TO +75°C	-	IP65	II 2 G EX DB MB IIC T4/T5	461
2.0/2.1	483371	EXPLOSION PROOF INCREASED SAFETY ELECTRICAL PART "EB", 50 MM	8.0	8.0	-40°C TO +65°C	-	IP67	II 2 G EX EB IIC T4	462
2.0/2.1	494040	EXPLOSION PROOF INCREASED SAFETY ELECTRICAL PART "EB", 50 MM	8.0	8.0	-40°C TO +90°C	-	IP67	II 2 G EX EB IIC T3/T4	462
2.0/2.1	492190	EXPLOSION PROOF INCREASED SAFETY AND ENCAPSULATED ELECTRICAL PART "EB", 50 MM	9.0	11.0	-40°C TO +75°C	-	IP66	II 2 G EX EB MB IIC T3/T4	465
2.0/2.1	488553	COIL WITH SCREW TERMINAL, DOUBLE FREQUENCY, H CLASS, 40 MM	-	9.0	-40°C TO +50°C	-	IP 44 TO 67	-	439
2.0/2.2	492425	COILS FOR DIN PLUG CONNECTION, HIGH TEMPERATURE, 32 MM	14.0	14.0	-40°C TO +50°C	-	IP65	-	419
2.0/2.2	481044	COIL WITH SCREW TERMINAL HIGH POWER, 40 MM	-	14.0	-40°C TO +50°C	-	IP 44 TO 67	-	435
2.0/2.2	486265	COIL WITH SCREW TERMINAL, HIGH TEMPERATURE-HIGH POWER, 40 MM	14.0	14.0	-40°C TO +50°C	-	IP 44 TO 67	-	436
2.0/2.2	495880	EXPLOSION PROOF ELECTRICAL PART "NAC NCC", 32 MM	14.0	14.0	-40°C TO +50°C	-	IP65	II 3 G EX NAC NCC IIC T3	449
2.0/2.2	496155	EXPLOSION PROOF INCREASED SAFETY ELECTRICAL PART "NAC NCC", 50 MM	14.0	14.0	-40°C TO +65°C	-	IP67	II 3 G EX NAC NCC IIC T3	451
2.2	483816	COIL FOR DIN PLUG CONNECTION FOR JET VALVES, 32 MM	14.0	14.0	-40°C TO +50°C	-	IP65	-	424

INDEX BY COIL GROUP

Coil Group	Coil Reference	Designation	Power DC Pn (W)	Power AC Pn (W)	Ambient Temperature	UL	Degree of Protection	ATEX or NEMA 4X Protection (Gas)	Page
3.0	482730	COILS FOR DIN PLUG CONNECTION, REDUCED POWER, 32 MM	7.0	6.0	-40°C TO +50°C	-	IP65	-	420
3.0	495875	EXPLOSION PROOF ELECTRICAL PART "NAC NCC", 32 MM	7.0	6.0	-40°C TO +50°C	-	IP65	II 3 G EX NAC NCC IIC T3/T4	448

INDEX BY VALVE REFERENCE

Valve Reference	Page	Valve Reference	Page	Valve Reference	Page	Valve Reference	Page
E 131E03	178,274	E 121K0352	24,62	121KH1050	138	122K8406	28,114
U 033X0111	298	121K0397	24	121M13	22,62	122K9321	158
U 033X5156	370	E 121K04	22,112	121M14	22,62	122K9363	28,114
U 033X5195	374	E 121K0402	22,62	121V5106	130	122V8306	132
U 033X5256	376	121K0497	22	121V5112	130	125K01	28,66
U 033X7759	372	E 121K07	22	121V5163	104,130	125K03	28
121F2523	158	121K0706	22,62	121V5206	130	131B04	192
E 121F43	30,116	121K1302	22	121V5212	130	131B14	192
E 121F4302	30,68	E 121K14	22,112	121V5263	104,130	E 131F26	196
E 121F44	30,116	E 121K23	22,112	121V5306	128	E 131F43	188
E 121F4406	30,68	121K2423	156	121V5363	104,128	E 131F4350	188
121F4417	30	121K3106	26,64,114	121V5397	130	131F4397	280
121F47	30	121K3206	26,64,114	121V5406	128	E 131F44	188
121F4706	30,116	121K3303	102	121V5463	104,128	131F4410	186
121F63	30,116	121K3306	26,64,114	121V5497	128	E 131F4450	188
121F64	30,116	121K3321	156	U 121V5595	148	131F4490	186
121F67	30,116	E 121K45	26,64	121V5706	128	131F46	188
121FH0015	138	E 121K4503	102	121V5763	104,128	131F4650	188
121FH0020	138	E 121K46	26,64	U 121V7595	148	U 131F5295	354
121FH0025	138	E 121K4603	102	U 121VS3750A	148	131F5406	194
121FH0030	138	121K6220	156	121ZH0010	136	U 131F7695	354
121FH1015	138	E 121K63	24,112	121ZH0015	136	131FH0315	226
121FH1020	138	E 121K64	24,112	121ZH0020	136	131FH0320	226
121FH1025	138	121K6423	156	121ZH0025	136	131FH0325	226
121FH1030	138	E 121K65	22,112	121ZH0030	136	131FH0330	226
121G2520	156	E 121K67	22,112	121ZH1010	136	131FH1115	226
121G2523	156	121KH0015	138	121ZH1015	136	131FH1120	226
121K01	24,62	121KH0020	138	121ZH1020	136	131FH1125	226
121K0103	102	121KH0025	138	121ZH1025	136	131FH1130	226
121K0150	24,62	121KH0030	138	121ZH1030	136	131FH1315	226
121K02	24,62	121KH1015	138	122F44	32	131FH1320	226
121K0250	24,62	121KH1020	138	122K83	28	131FH1325	226
E 121K03	24,112	121KH1025	138	122K8306	28,64	131FH1330	226
E 121K0302	24,62	121KH1030	138	122K8321	156,114	E 131K03	178
121K0323	102	121KH1040	138	122K84	28,114	E 131K0308	178,274

INDEX BY VALVE REFERENCE

Valve Reference	Page	Valve Reference	Page	Valve Reference	Page	Valve Reference	Page
E 131K0350	178,274	131T2101	274	132K04	180	U 133X5196	346
E 131K0358	176,270	131T22	178	132K06	180	U 133X5296	352
131K0397	176	131T23	174	132T22	180	U 133X7195	356
E 131K04	174,272	131T2301	174	132T23	180	U 133X7709	348
E 131K0450	174,272	131T29	176	132T2301	178	U 133X77591	348
131K0490	172,270	131T2901	176	132T29	180	135K03	278
131K0497	174,270	131V5306	214	133F4650	280	135K04	184
E 131K06	176,272	131V5363	214	E 133K03	182	2019F1GRG7	140
131K0648	240	131V5397	214	E 133K0350	182	2019F1GVG7	140
E 131K0650	176,272	131V5406	214	E 133K04	182	2019F1JRG7	140
E 131K13	172	131V5463	214	E 133K0450	182	2019F1JVG7	140
E 131K14	172	131V5490	214	133K0497	182	2019F1LRG7	140
131K16	172	131V5497	214	E 133K05	182	2019F1LVG7	140
131K1650	172	131X1101	302	E 133K06	182	2019F1NRG7	140
E 131K63	178	U 131X1101	302	E 133K0650	182	2019F1NVG7	140
E 131K6350	178	131X1131	302	E 133K13	182	2019F1QEG7	140
E 131K64	174	U 131X1201	356	E 133K14	182	2019F1QVG7	140
E 131K6450	174	131ZH0125	222	E 133K16	182	2019F1SEG7	140
131KH0115	224	131ZH0130	222	133T21	182	2019F1SVG7	140
131KH0120	224	131ZH0315	222	133T2101	184	201LG1GVG2	144
131KH0125	224	131ZH0320	222	133T23	182	201LG1JVG2	144
131KH0130	224	131ZH0325	222	133T2301	182	201LG1LVG2	144
131KH1115	224	131ZH0330	222	133V5306	216	201LG2GVG2	144
131KH1120	224	131ZH1115	222	133V5363	216	201LG2JVG2	144
131KH1125	224	131ZH1120	222	133V5406	216	201LG2LVG2	144
131KH1130	224	131ZH1125	222	133V5463	216	201LG2NVG7	144
131KH1140	224	131ZH1130	222	U 133V5595	344	201LG3SVG7	144
131KH1150	224	131ZH1315	222	U 133V5695	344	201LG3UVG7	144
131M14	172,270	131ZH1320	222	U 133V7595	344	201LG4SVG6	144
131M15	172,270	131ZH1325	222	U 133V7695	344	201LG4UVG7	144
131M74	186	131ZH1330	222	133X01	282	202LG2NVG7	146
131M7450	186	132F43	188	U 133X01	282	202LG2SVG7	146
131M75	186	132F44	188	U 133X0111	276	202LG4SVG7	146
131M7550	186	132F46	188	U 133X5156	346	202LG4UVG7	146
131T21	178	132K03	180	U 133X5195	354	221G13	34

INDEX FOR VALVES

Valve Reference	Page	Valve Reference	Page	Valve Reference	Page	Valve Reference	Page
221G1303	106	221G6506	150	321F2523	164	E 321K13	42,74
221G1330	106	221G6536	150	E 321F32	58,86	E 321K1314	42
221G15	34	221G6606	152	E 321F3202	58,124	E 321K15	44,76
221G1503	106	221G6636	152	321F35	58	E 321K1503	108
221G1530	34	221J3301E	168	E 321G36	46,78	321K1523	236
221G16	36	3019F1GRG7	198,228	E 321G3606	46	321K1535	234
221G1603	106	3019F1GVG7	198,228	E 321G3610	94	321K1536	236
221G1610	36	3019F1JRG7	198,228	E 321G37	48,80	321K1537	236
221G1630	36	3019F1JVG7	198,228	E 321G3706	48	321K1543	234
221G1631	36	3019F1LRG7	198,228	E 321G3710	96	E 321K25	44,76
221G17	38	3019F1LVG7	198,228	321G3790	48	321K31	40,74
221G1703	106	3019F1NRG7	198,228	E 321G38	48,80	321K3106	40
221G1710	38	3019F1NVG7	198,228	E 321G3806	48	321K33	42,74
221G1730	38	3019F1QEG7	198,228	E 321G3810	96	321K3306	42
221G1731	90	3019F1QVG7	198,228	E 321G39	50,80	321K35	44,76
221G21	38	3019F1SEG7	198,228	E 321G3906	50	321K3506	44
221G2103	90	3019F1SVG7	198,228	E 321G3910	96	321K36	46,78
221G2106	38	301LG1GVG2	220	321G3990	50	321K3606	46
221G2110	38	301LG1LVG2	220	E 321G40	50,80	321K37	48,80
221G2130	38	301LG2GVG2	220	E 321G4006	50	321K3706	48
221G2131	90	301LG2GVG7	220	E 321G4010	96	321K4106	74,94
221G2136	38	301LG2LVG2	220	321G4090	50	321K4156	40
221G23	34	301LG2NVG7	220	E 321H11	40,118	321K4306	74,94
221G2330	34	301XGFRTJ7	228	E 321H13	42,118	321K4356	42
221G25	34	3039F1GEG7	198,224	E 321H15	44,120	321K4506	76,94
221G2523	160	3039F1GVG7	200	321H1590	44	321K4556	76,94
221G2530	34	3039F1JEG7	200,230	E 321H21	118,162	321K4606	78,94
221G26	36	3039F1JVG7	200,230	E 321H23	118,162	321K4656	78,94
221G2630	36	3039F1JVG7	200,230	321H2322	162	321K4706	80,96
221G27	38	3039F1LEG7	200,230	E 321H25	120,164	321K4756	80,96
221G2730	38	3039F1LVG7	200,230	321H2522	164	E 321K63	118
221G6106	152	3039F1LVG7	200,230	321H2523	164	322F35	58
221G6136	152	3039F1NEG7	200,230	321H35	44	322F72	58
221G6306	150	3039F1NVG7	200,230	321H36	46	322F7206	58,124
221G6336	150	3039F1NVG7	200,230	E 321K10	40,74	322G36	54,84

INDEX FOR VALVES

Valve Reference	Page	Valve Reference	Page	Valve Reference	Page	Valve Reference	Page
322G3606	54	331B02	210	341L9504	330	341P02	286
322G3610	98	331B0216	210	341L9534	330	U 341P0250	358
322G37	54,86	E 331B21	204	341L9594	332	341P03	286
322G3706	54	E 331B74	202	341L9597	332	341P04	290
322G3710	98	331B7490	202	341L9598	332	341P21	284
322G38	54	E 331L21	206	341N01	308	341P2108	284
322G3806	54	331N03	304	341N02	314	341P2190	286
322G3810	98	331N04	304	U 341N0250	366	341P2197	284
322G39	54,86	331N34	306	341N04	318	341P22	288
322G3906	54	E 332B01	204	341N05	312	341P2290	288
322G3910	98	332B02	204	341N0502	314	341P2297	288
322G40	54	E 332B21	206	341N11	308	U 341P3250	358
322G4006	54	E 341B01	246	341N12	316	U 341P3292	360
322G4010	98	341B02	244	341N21	308	U 341P3295	360
322G75	52,84	E 341B21	246	341N2190	308	341P33	286
322G7506	52,122	341B34	244	341N22	316	341P34	290
322H35	52	341B3403	244	341N31	310	342N03	326
322H36	54	341B3440	244	341N3102	310	342N11	326
322H71	52	341B3490	244	341N3108	310	342N3197	326
322H7106	52,122	E 341F21	246	341N3128	310	342N33	326
322H73	52,122	341F34	252	341N3130	310	343N03	328
322H7306	52,122	341F3403	252	341N3190	310	345B04	248
322H75	52,122	341F3440	252	341N3196	310	345B34	248
322H7506	52,122	E 341L01	262	341N3197	310	345F34	252
322K4106	84	341L0197	262	341N32	316	345L01	264
322K4306	84	E 341L02	260	341N3202	316	345L21	256
322K4506	84	341L04	262	U 341N3250	364	345N31	330
322K4606	84	341L05	262	341N3290	312	345P21	296
322K4706	86	341L11	258	U 341N3292	364	347L04	256
325K4106	56	E 341L1130	258	U 341N3295	364	347L11	260
325K4306	56	U 341L1130	258	341N3297	312	E 347L1130	260
325K4506	56	E 341L21	254	341N34	318	347L9101	250
325K4606	56	341L2190	254	341N35	314	347L9201	256
325K4706	56	341L9101	250	341N3502	314	347N03	322
E 331B01	202	341L9201	254	341P01	284	347N04	324

INDEX FOR VALVES

Valve Reference	Page	Valve Reference	Page	Valve Reference	Page
347N11	320	443788W	92	444601W	82
347N12	322	443789W	70	444602W	82
347N31	320	443790W	72	444603W	82
347N3190	320	443791W	72	444604W	82
347N3197	320	443792W	92	444605W	82
347N32	322	443793W	72	542N03	340
U 347N3250	368	443794W	72	547N03	338
347N33	322	443795W	72		
347N34	324	443796W	92		
347P01	292	443797W	72		
347P02	294	443798W	72		
347P03	294	443799W	72		
347P04	296	443800W	92		
347P21	292	443801W	72		
347P2190	292	443802W	92		
347P2197	292	443803W	92		
347P22	294	443804W	70		
U 347P3250	362	443805W	82		
U 347P3295	362	443806W	82		
347P33	294	443807W	82		
347P34	296	443808W	82		
421F35	58	443809W	82		
U 441P3250	358	443810W	82		
443776W	70	443811W	82		
443777W	70	444492W	70		
443778W	70	444494W	70		
443779W	70	444497W	70		
443780W	70	444499W	82		
443781W	70	444500W	82		
443782W	70	444501W	82		
443783W	70	444502W	82		
443784W	92	444503W	82		
443785W	70	444513W	82		
443786W	70	444576W	82		
443787W	70	444600W	82		

KOVANZ.COM

Parker's Motion & Control Technologies

At Parker, we're guided by a relentless drive to help our customers become more productive and achieve higher levels of profitability by engineering the best systems for their requirements. It means looking at customer applications from many angles to find new ways to create value.

Whatever the motion and control technology need, Parker has the experience, breadth of product and global reach to consistently deliver. No company knows more about motion and control technology than Parker.

For further info call
00800 27 27 5374



Aerospace

Key Markets

Aftermarket services
Commercial transports
Engines
General & business aviation
Helicopters
Launch vehicles
Military aircraft
Missiles
Power generation
Regional transports
Unmanned aerial vehicles

Key Products

Control systems & actuation products
Engine systems & components
Fluid conveyance systems & components
Fluid metering, delivery & atomization devices
Fuel systems & components
Fuel tank inerting systems
Hydraulic systems & components
Thermal management
Wheels & brakes



Climate Control

Key Markets

Agriculture
Air conditioning
Construction Machinery
Food & beverage
Industrial machinery
Life sciences
Oil & gas
Precision cooling
Process
Refrigeration
Transportation

Key Products

Accumulators
Advanced actuators
CO₂ controls
Electronic controllers
Filter driers
Hand shut-off valves
Heat exchangers
Hose & fittings
Pressure regulating valves
Refrigerant distributors
Safety relief valves
Smart pumps
Solenoid valves
Thermostatic expansion valves



Hydraulics

Key Markets

Aerial lift
Agriculture
Alternative energy
Construction machinery
Forestry
Industrial machinery
Machine tools
Marine
Material handling
Mining
Oil & gas
Power generation
Refuse vehicles
Renewable energy
Truck hydraulics
Turf equipment

Key Products

Accumulators
Cartridge valves
Electrohydraulic actuators
Human machine interfaces
Hybrid drives
Hydraulic cylinders
Hydraulic motors & pumps
Hydraulic systems
Hydraulic valves & controls
Hydrostatic steering
Integrated hydraulic circuits
Power take-offs
Power units
Rotary actuators
Sensors



Pneumatics

Key Markets

Aerospace
Conveyor & material handling
Factory automation
Life science & medical
Machine tools
Packaging machinery
Transportation & automotive

Key Products

Air preparation
Brass fittings & valves
Manifolds
Pneumatic accessories
Pneumatic actuators & grippers
Pneumatic valves & controls
Quick disconnects
Rotary actuators
Rubber & thermoplastic hose & couplings
Structural extrusions
Thermoplastic tubing & fittings
Vacuum generators, cups & sensors





Electromechanical

Key Markets

Aerospace
 Factory automation
 Life science & medical
 Machine tools
 Packaging machinery
 Paper machinery
 Plastics machinery & converting
 Primary metals
 Semiconductor & electronics
 Textile
 Wire & cable

Key Products

AC/DC drives & systems
 Electric actuators, gantry robots & slides
 Electrohydraulic actuation systems
 Electromechanical actuation systems
 Human machine interface
 Linear motors
 Stepper motors, servo motors, drives & controls
 Structural extrusions



Filtration

Key Markets

Aerospace
 Food & beverage
 Industrial plant & equipment
 Life sciences
 Marine
 Mobile equipment
 Oil & gas
 Power generation & renewable energy
 Process
 Transportation
 Water Purification

Key Products

Analytical gas generators
 Compressed air filters & dryers
 Engine air, coolant, fuel & oil filtration systems
 Fluid condition monitoring systems
 Hydraulic & lubrication filters
 Hydrogen, nitrogen & zero air generators
 Instrumentation filters
 Membrane & fiber filters
 Microfiltration
 Sterile air filtration
 Water desalination & purification filters & systems



Fluid & Gas Handling

Key Markets

Aerial lift
 Agriculture
 Bulk chemical handling
 Construction machinery
 Food & beverage
 Fuel & gas delivery
 Industrial machinery
 Life sciences
 Marine
 Mining
 Mobile
 Oil & gas
 Renewable energy
 Transportation

Key Products

Check valves
 Connectors for low pressure fluid conveyance
 Deep sea umbilicals
 Diagnostic equipment
 Hose couplings
 Industrial hose
 Mooring systems & power cables
 PTFE hose & tubing
 Quick couplings
 Rubber & thermoplastic hose
 Tube fittings & adapters
 Tubing & plastic fittings



Process Control

Key Markets

Alternative fuels
 Biopharmaceuticals
 Chemical & refining
 Food & beverage
 Marine & shipbuilding
 Medical & dental
 Microelectronics
 Nuclear Power
 Offshore oil exploration
 Oil & gas
 Pharmaceuticals
 Power generation
 Pulp & paper
 Steel
 Water/wastewater

Key Products

Analytical Instruments
 Analytical sample conditioning products & systems
 Chemical injection fittings & valves
 Fluoropolymer chemical delivery fittings, valves & pumps
 High purity gas delivery fittings, valves, regulators & digital flow controllers
 Industrial mass flow meters/controllers
 Permanent no-weld tube fittings
 Precision industrial regulators & flow controllers
 Process control double block & bleeds
 Process control fittings, valves, regulators & manifold valves



Sealing & Shielding

Key Markets

Aerospace
 Chemical processing
 Consumer
 Fluid power
 General industrial
 Information technology
 Life sciences
 Microelectronics
 Military
 Oil & gas
 Power generation
 Renewable energy
 Telecommunications
 Transportation

Key Products

Dynamic seals
 Elastomeric o-rings
 Electro-medical instrument design & assembly
 EMI shielding
 Extruded & precision-cut, fabricated elastomeric seals
 High temperature metal seals
 Homogeneous & inserted elastomeric shapes
 Medical device fabrication & assembly
 Metal & plastic retained composite seals
 Shielded optical windows
 Silicone tubing & extrusions
 Thermal management
 Vibration dampening

ENGINEERING YOUR SUCCESS.

KOVANZ.CZ

www.parker.com



EMEA Product Information Centre
Free phone: 00 800 27 27 5374
US Product Information Centre
Toll-free number: 1-800-27 27 537
www.parker.com

Your authorized Distributor