

## PF Gear pump flange straight

Hydraulic flange / Female BSPB thread

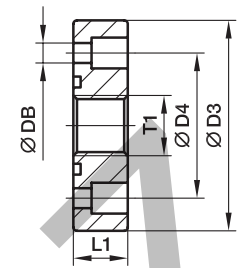

Pump size	LK	T1	D3	D4	L1	DB	Bolts (metr.)	O-ring	Weight (steel) kg/piece	Order code*	PN (bar) <sup>1)</sup> CF
1.0	30.0	<b>G 3/8</b>	45	30.0	13	6.5	M 06×16	18.77×1.78	0.15	<b>PF1</b>	315
2.0	40.0	<b>G 1/2</b>	58	40.0	15	8.5	M 08×20	25.12×1.78	0.29	<b>PF2</b>	315
3.0	51.0	<b>G 3/4</b>	75	51.0	18	10.5	M 10×25	31.42×2.62	0.58	<b>PF3</b>	315
3B	56.0	<b>G 3/4</b>	76	56.0	18	10.5	M 10×25	31.42×2.62	0.61	<b>PF3B</b>	315
3.5	62.0	<b>G 1</b>	88	62.0	20	10.5	M 10×25	39.69×3.53	0.84	<b>PF3.5</b>	315
3.5B	62.0	<b>G 1</b>	88	62.0	20	12.5	M 12×35	39.69×3.53	0.82	<b>PF3.5B</b>	315
4.0	72.5	<b>G 1 1/4</b>	98	72.5	22	12.5	M 12×30	47.22×3.53	1.06	<b>PF4</b>	315

## PFL Gear pump flange straight

Hydraulic flange / Female BSBP thread – long version

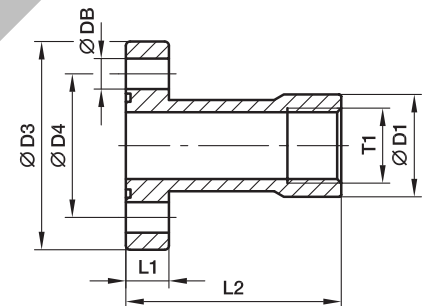

Pump size	LK	T1	D1	D3	D4	L1	L2	DB	Bolts (metr.)	O-ring	Weight (steel) kg/piece	Order code*	PN (bar) <sup>1)</sup> CF
1.0	30.0	<b>G 3/8</b>	21.0	45	30.0	10	55	6.5	M 06×20	18.77×1.78	0.20	<b>PFL1</b>	315
2.0	40.0	<b>G 1/2</b>	26.5	58	40.0	12	60	8.5	M 08×25	25.12×1.78	0.39	<b>PFL2</b>	315
3.0	51.0	<b>G 3/4</b>	33.5	76	51.0	16	72	10.5	M 10×35	31.42×2.62	0.79	<b>PFL3</b>	315
3B	56.0	<b>G 3/4</b>	33.5	76	56.0	16	72	10.5	M 10×35	31.42×2.62	0.79	<b>PFL3.5</b>	315

<sup>1)</sup> Pressure shown = Item deliverable

$$\frac{\text{PN (bar)}}{10} = \text{PN (MPa)}$$

\*Please add the **suffixes** below according to the material/surface required.

Order code suffixes			
Material	Suffix surface and material	Example incl. metr. bolts and O-ring	Standard sealing material (no additional suffix needed)
Steel, zinc plated, Cr(VI)-free	<b>PF</b> CF	PF1CFM	NBR
Steel, zinc plated, Cr(VI)-free	<b>PFL</b> CF	PFL1CFM	NBR