

PAFS-90S SAE 90° 4 bolt flange (socket weld)

SAE 90° Flange / Socket weld tube end
(ISO 6162-1/-2)

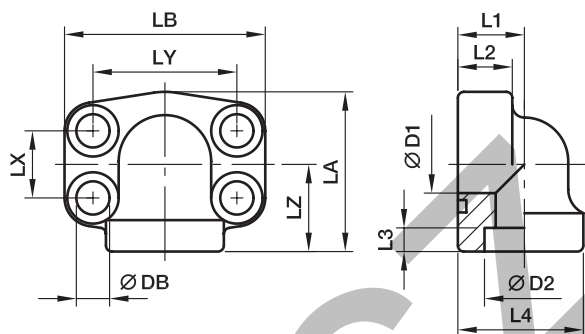

3000 PSI Series

Nom. flange size		⊕ max.	D1	D2	L1	L2	L3	L4	LX	LY	LZ	DB	Bolts		Weight (steel) kg/piece	Order code*	PN (bar) ¹⁾	
SAE (in.)	ISO (DN)												(metr.)	(unc.)			S	SS
1/2	13	21.3	13	21.6	18	17	5	34.0	17.5	38.1	28	8.9	M 08×30	5/16×1 1/4	0.45	PAFS080/90S21.6	345	345
3/4	19	26.9	19	27.2	22	18	5	38.5	22.2	47.6	25	10.6	M 10×35	3/8×1 1/2	0.50	PAFS100/90S27.2	345	345
1	25	33.7	25	34.1	28	19	6	44.5	26.2	52.4	28	10.6	M 10×35	3/8×1 1/2	0.55	PAFS102/90S34.1	345	345
1 1/4	32	42.4	31	42.8	30	22	7	53.5	30.2	58.7	34	10.6***	M 10×40	7/16×1 1/2	0.88	PAFS104/90S42.8	276	276
1 1/2	38	48.3	38	48.6	36	25	8	62.5	35.7	69.9	43	13.3	M 12×45	1/2×1 3/4	1.28	PAFS106/90S48.6	207	207
2	51	60.3	50	61.0	41	25	10	77.0	42.9	77.8	50	13.3	M 12×45	1/2×1 3/4	1.72	PAFS108/90S61	207	207
2 1/2	64	76.1	60	76.6	50	25	28	85.0	50.8	88.9	77	13.3	M 12×45	1/2×1 3/4	3.11	PAFS110/90S76.6	172	172

6000 PSI Series

1/2	13	21.3	13	21.6	18	17	5	34.0	18.2	40.5	28	8.9	M 08×30	5/16×1 1/4	0.35	PAFS401/90S21.6	420	420
3/4	19	26.9	19	27.2	28	19	6	44.5	23.8	50.8	28	10.6	M 10×35	3/8×1 1/2	0.76	PAFS402/90S27.2	420	420
1	25	33.7	25	34.1	30	24	7	53.5	27.8	57.2	34	13.3***	M 12×50	7/16×1 1/2	0.96	PAFS403/90S34.1	420	420
1 1/4	32	42.4	31	42.8	36	25	8	62.5	31.8	66.6	43	15.0**	M 14×45	1/2×1 3/4	1.77	PAFS404/90S42.8	420	420
1 1/4	32	42.4	31	42.8	36	25	8	62.5	31.8	66.6	43	13.3	M 12×45	–	1.77	PAFS404/12/90S42.8	420	420
1 1/2	38	48.3	38	48.6	41	26	10	77.0	36.5	79.3	50	16.7	M 16×55	5/8×2 1/4	2.24	PAFS405/90S48.6	420	420
2	51	60.3	50	61.0	45	35	12	89.0	44.5	96.8	65	20.6	M 20×70	3/4×2 3/4	3.48	PAFS406/90S61	420	420

**DB = 13.3 for UNC Bolts

***DB = 12 for UNC Bolts

1) Pressure shown = Item deliverable

PN (bar)
10 = PN (MPa)

The pressures given here are the maximum allowable for the flange fittings. If the pipe or tube used has a lower pressure rating, then the welded assembly rating will be the lower one, assuming the weld is adequately strong.

Stainless steel parts may have dimensional deviations. Additional information on request.

*Please add the **suffixes** below according to the material/surface required.

Order code suffixes					
Material	Suffix surface and material	Example only 4 bolt flange	Example 4 bolt flange incl. metr. bolts and O-ring	Example 4 bolt flange incl. UNC bolts and O-ring	Standard sealing material (no additional suffix needed)
Steel, blanc oil dipped	S	PAFS080/90S21.6S	PAFS080/90S21.6SM	PAFS080/90S21.6SU	NBR
Stainless steel	SS	PAFS080/90S21.6SS	PAFS080/90S21.6SSM	–	VIT