

Regulator / Pilot Regulator

Symbols

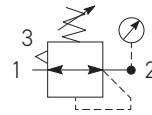

Self relieving regulator with gauge

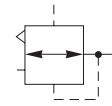

Air pilot

- Flanged 1-1/2" or 2" ports (BSPP & NPT)
- Robust die-cast aluminium construction
- Secondary pressure ranges 8 & 16 bar
- Rolling diaphragm for extended life
- Secondary aspiration plus rolling diaphragm provides quick response and accurate pressure regulation
- Air pilot regulator permanent bleed

Options:

P 3 Z R A			B	N		N	
SAE Mtg - No thread	0	None	0	Relieving	B	0 - 8 bar No Gauge	N
BSPP flange	1	1-1/2"	B			0 - 16 bar No Gauge	H
NPT flange	9	2"	C			0 - 8 bar Gauge	G
						0 - 16 bar Gauge	J

P 3 Z R A			B P P N
For Air Pilot Regulator option			

Port size	Description	Order Code	Flow dm ³ /s *	Max bar	Min temp °C	Max temp °C	Height mm	Width mm	Depth mm	Weight kg
-	8 bar relieving + gauge	P3ZRA00BNGN	>666	17.5	0	60	230	180	132	3.5
-	8 bar relieving	P3ZRA00BNNN	>666	17.5	0	60	230	180	132	3.5
1-1/2"	8 bar relieving + gauge	P3ZRA1BBNGN	>666	17.5	0	60	230	180	132	3.5
1-1/2"	8 bar relieving	P3ZRA1BBNNN	>666	17.5	0	60	230	180	132	3.5
2"	8 bar relieving + gauge	P3ZRA1CBNGN	>666	17.5	0	60	230	180	132	3.5
2"	8 bar relieving	P3ZRA1CBNNN	>666	17.5	0	60	230	180	132	3.5
-	16 bar relieving + gauge	P3ZRA00BNJN	>666	17.5	0	60	230	180	132	3.5
-	16 bar relieving	P3ZRA00BNHN	>666	17.5	0	60	230	180	132	3.5
1-1/2"	16 bar relieving + gauge	P3ZRA1BBNJN	>666	17.5	0	60	230	180	132	3.5
1-1/2"	16 bar relieving	P3ZRA1BBNHN	>666	17.5	0	60	230	180	132	3.5
2"	16 bar relieving + gauge	P3ZRA1CBNJN	>666	17.5	0	60	230	180	132	3.5
2"	16 bar relieving	P3ZRA1CBNHN	>666	17.5	0	60	230	180	132	3.5
-	Pilot Regulator	P3ZRA00BPPN	>666	17.5	0	60	182	180	132	3.4
1-1/2"	Pilot Regulator	P3ZRA1BBPPN	>666	17.5	0	60	182	180	132	3.4
2"	Pilot Regulator	P3ZRA1CBPPN	>666	17.5	0	60	182	180	132	3.4

* flow with 10 bar inlet 6,3 bar set pressure and 1 bar pressure drop.

Technical Information

Fluid:	Compressed air
Maximum inlet pressure*:	17.5 bar
Temperature range*:	0°C to +60°C
Typical flow with 10 bar inlet pressure, 8 bar set pressure and 1 bar pressure drop:	2" size >666 dm ³ /s
Gauge port (x 2):	1/4"

* Air supply must be dry enough to avoid ice formation at temperatures below +2°C

Dimensions (mm)

Pressure regulating valve, pilot operated with integrated pilot pressure regulating valve

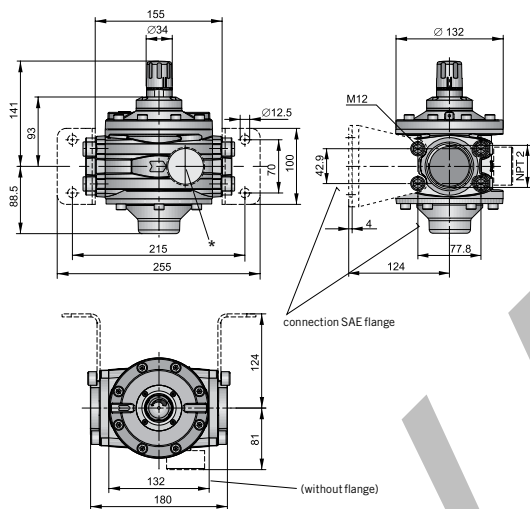

Material Specification

Body:	Aluminium
Bonnet:	Glass filled polyamide
Control Knob:	Glass filled polyamide
Valve:	Brass / NBR
Seals:	Nitrile NBR
Screws:	Steel / zinc plated

Flow characteristics

Pressure regulating valve characteristics - (2") Pilot operated

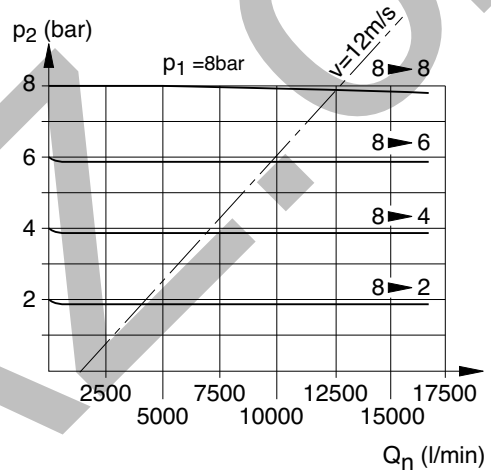

Pressure regulating valve, pilot operated

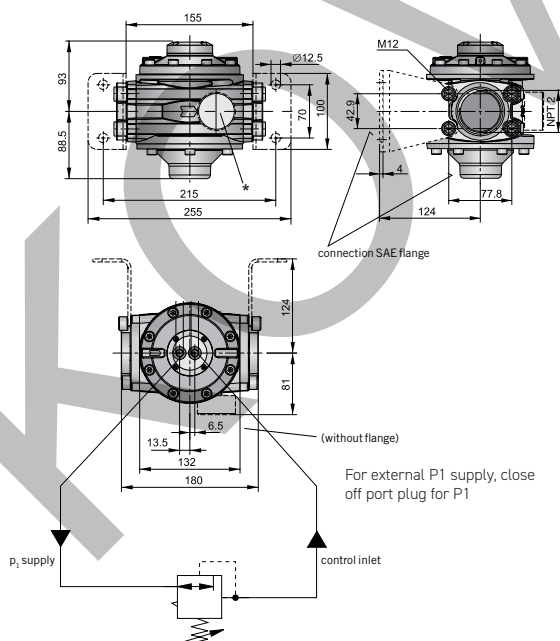

Service kits

Description	Order code
Diaphragm kit (relieving type)	P3ZKA00RR